

# TABLE OF CONTENTS

## INTRODUCTION

Purpose.....	1-1
Components.....	1-1
Front Panel Membrane.....	1-1
CPU Board.....	1-2
Fan.....	1-2
Relay Board.....	1-3
Input Terminal Board.....	1-4
Temperature Sensor.....	1-4
Pressure Transducer.....	1-4
Transformer.....	1-5
Control Circuit Plug Assemblies.....	1-5
Interconnect Cable.....	1-6

## INSTALLATION

General.....	2-1
Factory Installed EPC-2000.....	2-1
EPC-2000 Transformer.....	2-1
EPC-2000 Alarm Relay.....	2-1
EPC-2000 Switchback Relay.....	2-1
Compressor Control Relays.....	2-1
Defrost Input.....	2-2
Heat Reclaim Input.....	2-2
Factory Installed Satellite Compressor.....	2-2
Temperature Sensors.....	2-2
Pressure Transducer.....	2-2
Field Installed EPC-2000.....	2-3
Materials.....	2-3
Pre-Installation.....	2-4
Installation.....	2-4
Startup.....	2-5
Checkout Procedure.....	2-5

## OPERATION

Keypad Functional Description.....	3-1
Powering Up the System.....	3-2
The Time and Date Display.....	3-2
Passcodes.....	3-2
Entering Passocodes.....	3-3
STATUS MENU.....	3-6
MAINTENANCE MENU.....	3-8
SYSTEM MENU.....	3-10
ALARM MENU.....	3-13
Setting the Clock.....	3-14
EPC-2000 Alarm System.....	3-15
System Alarms Table.....	3-16
EPC-2000 Alarms Table.....	3-18

## TABLE OF CONTENTS

### CONFIGURATION

Purpose.....	4-1
Configuration Passcode.....	4-1
System/Configuration Menu.....	4-1
Factory Setup.....	4-1
Split Suction.....	4-3
Mixmatch, Round Robin and Sequential System.....	4-3
Suction Pressure Reset.....	4-5
Satellite Option.....	4-5
Condenser Fan Control Option.....	4-6
Units of Measurements.....	4-7
Zeroing.....	4-7

### SERVICE

Checkout and Troubleshooting Procedure .....	5-1
Recording Information .....	5-1
Apparent Malfunctions .....	5-2
Compressor Control Circuit Test .....	5-2
Switchback Mode Test .....	5-5
Stuck in Automatic .....	5-5
Stuck in Switchback .....	5-5
Alarm Relay Test .....	5-6
EPC Alarm Relay Will Not Signal Rack Alarm .....	5-6
Alarm Relay Stuck in Alarm .....	5-6
Power Supply Test .....	5-7
Suction Pressure Transducer and Cable Test .....	5-7
Temperature Sensor Checkout .....	5-8
Koolgas Relay and Heat Reclaim Relay Input Tests .....	5-9
Continuity Checks .....	5-10
Relay Board .....	5-10
Input Terminal Board .....	5-10
Cable .....	5-10
Troubleshooting Checkout Procedure Table .....	5-12
Replacement Parts List .....	5-14

### REVISION CHANGES ("B")

1. New EPC-2000 Faceplate, Cover Page
2. New Terminal Input Board, Figures 1-5 and 5-2
3. New Wiring Diagrams
4. Added section on Configuration, Page 4-1

## INTRODUCTION

### PURPOSE

The EPC-2000™ is the most advanced COMPRESSOR SYSTEM controller in the industry today. The electronics of this controller have been developed utilizing the most advanced technology available on the market. The EPC-2000 will control up to 8 compressors, or 6 compressors and 2 Satellites.

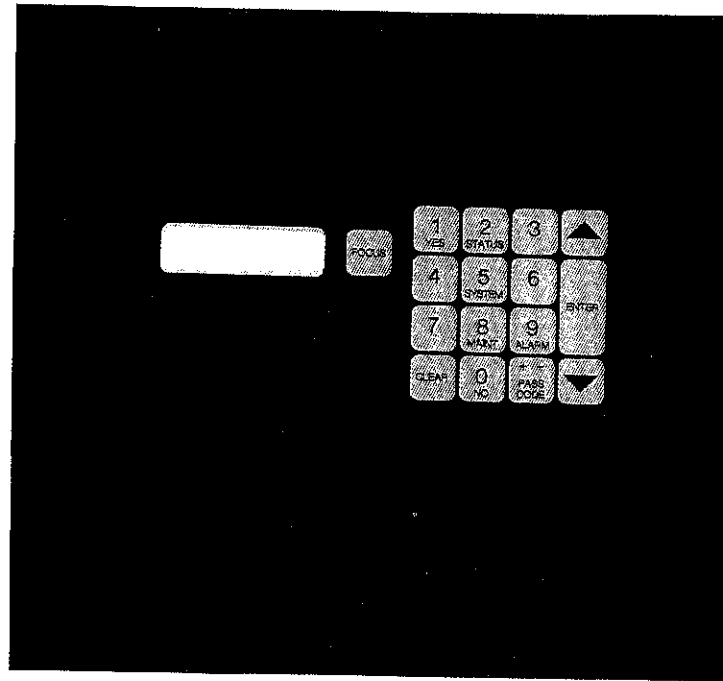

Figure 1-1. Front Panel Membrane

### COMPONENTS

#### Processor Components:

- Front Panel Membrane
- CPU Board
- Fan

#### Connected Components:

- Relay Board
- Input Terminal Board
- Temperature Sensor
- Pressure Transducer
- Transformer
- Control Circuit Plug Assemblies
- Interconnect Cables

#### Front Panel Membrane

The front panel membrane consists of a 16 button keypad and LCD display with a backlight. The keypad is a pressure sensitive touchpad which acknowledges each press of any key with an audible signal. Readouts or settings can be monitored or changed through the use of the keypad. The display has a two line, 16 character LCD readout, 32 characters in total. See Figure 1-1.

### CPU Board

The "CPU" board (Central Processing Unit) is located within the enclosure directly behind the front panel membrane. See Figures 1-2 and 1-3.

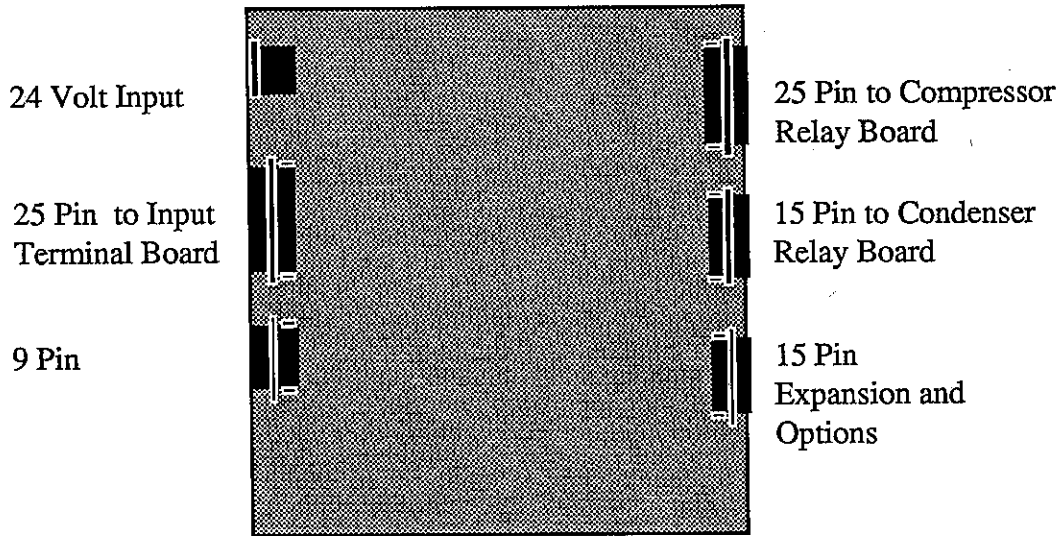

Figure 1-2. CPU Board

This board contains the internal power source for operation of the controller, the central processing unit (control chip), memory, and all input/output drivers.

There are 6 plugs located on the sides of the CPU board as labeled. The connections of the two 25 pin as well as the two 15 pin cables are not interchangeable. See Figure 1-2.

### Fan

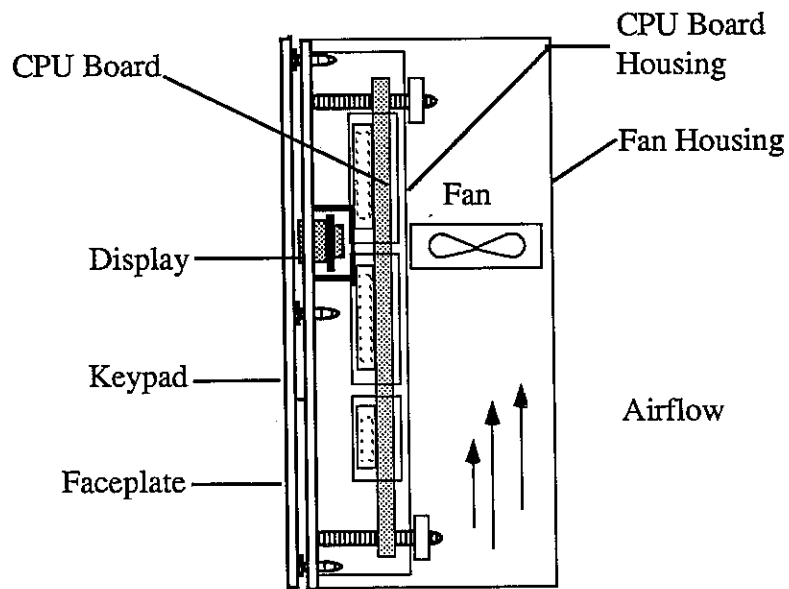

Figure 1-3. EPC-2000 Processor Assembly Cross-Section

The fan will turn on at 110° F and then turn off after dropping below 105° F. An alarm will be sounded if the temperature goes above 150° F. See Figure 1-3.

**Relay Board**

The relay board is connected by a 25 pin cable to the EPC-2000 processor assembly. See Figure 1-4. This board consists of the following 11 relays:

- A. 8 compressors ( may include a maximum of 2 Satellites)
- B. 1 Alarm
- C. 1 Switchback
- D. 1 Compressor disable (for when switchback occurs)  
 This relay deactivates the entire relay board.

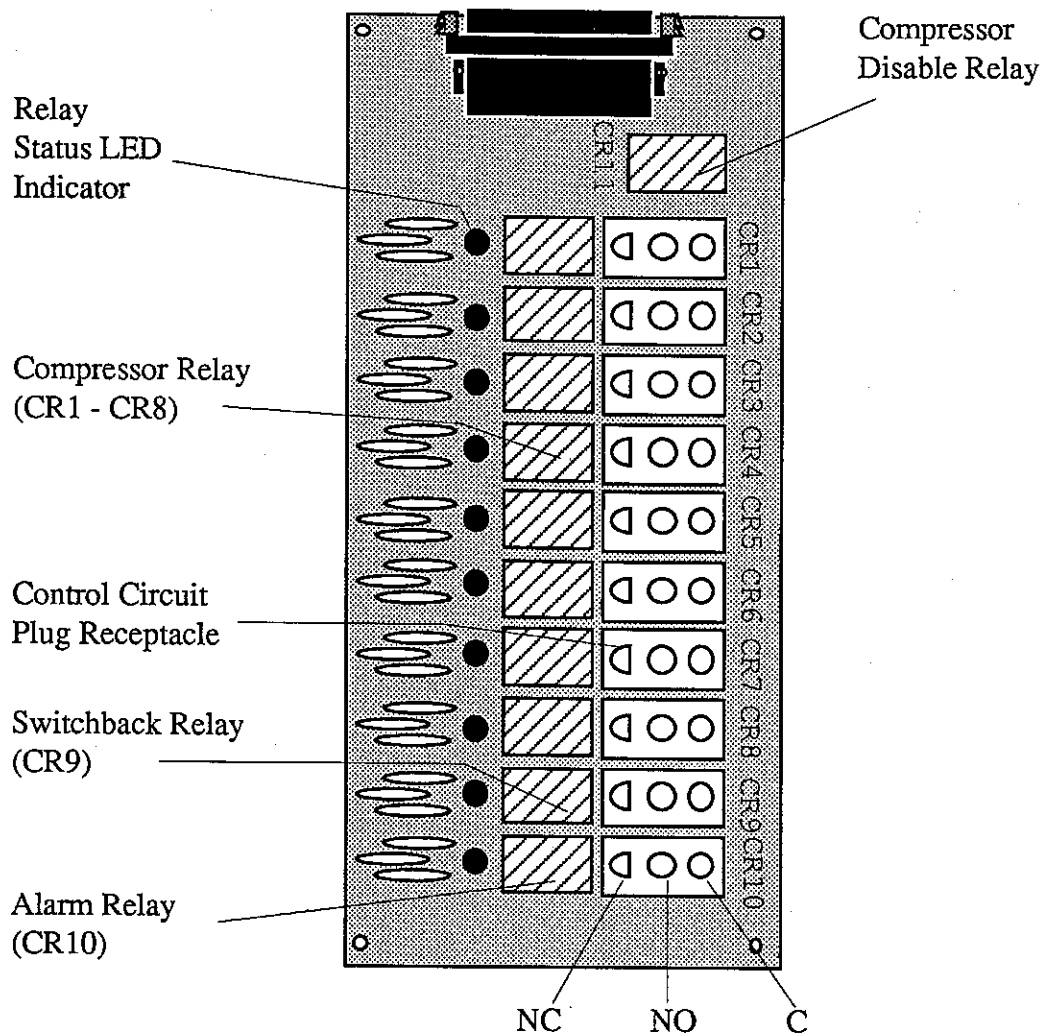

Figure 1-4. Compressor Control Relay Board

### Input Terminal Board

The input terminal board will accommodate the connections from all required inputs.  
See Figure 1-5.

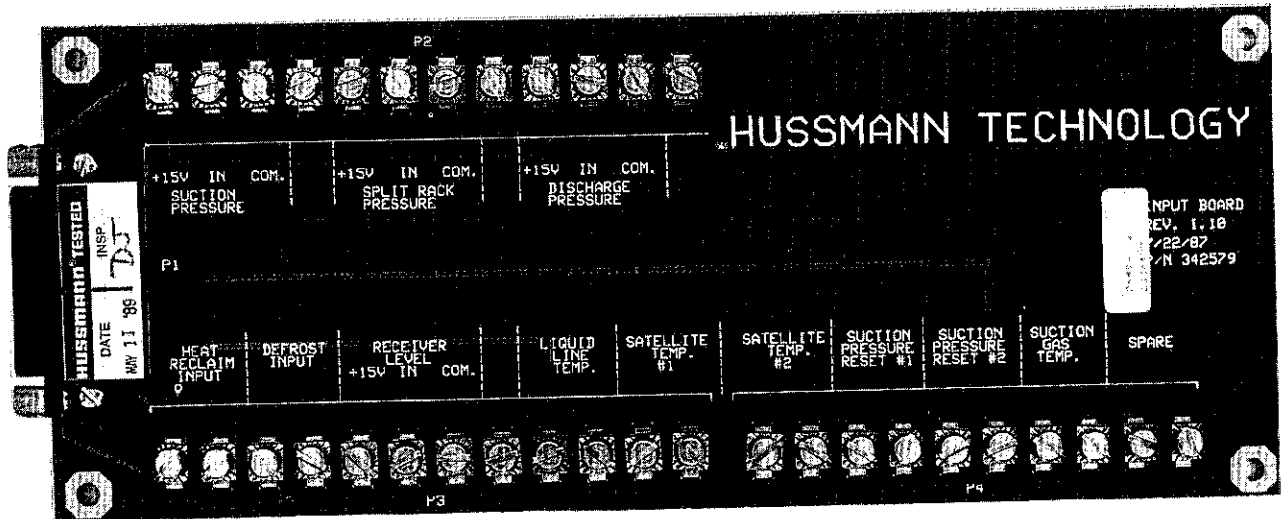

Figure 1-5. Input Terminal Board

### Temperature Sensor

The temperature probe is a fast response, non-polarized, resistive type sensor.  
See Figure 1-6.

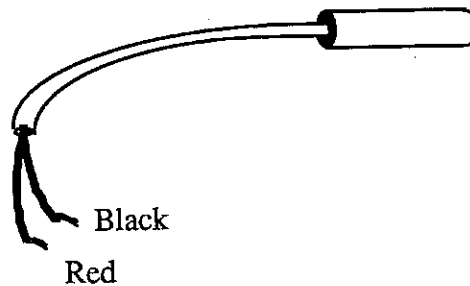

Figure 1-6. Temperature Sensor

### Pressure Transducer

The pressure transducer provides an analog signal back to the processor proportional to the pressure detected. See Figure 1-7.

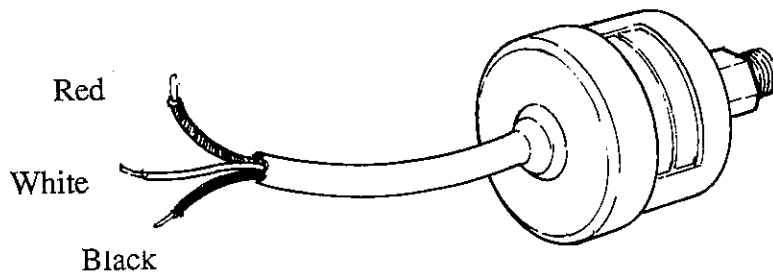

Figure 1-7. Typical Pressure Transducer

### Transformer

The control transformer is the power source for the EPC-2000, providing conversion from power line voltages to 24V AC. See Figure 1-8. The transformer is connected to the processor assembly by the power plug assembly. See Figure 1-12.

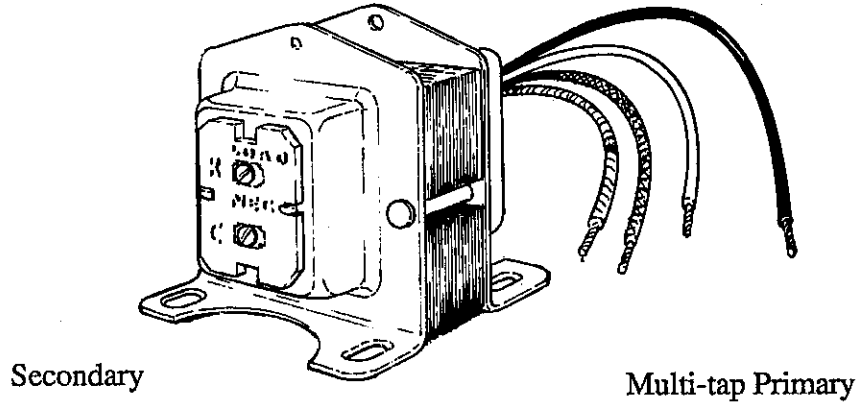

Figure 1-8. Control Transformer

### Control Circuit Plug Assemblies

The control circuit plug assemblies connect the Super Plus control circuit to the relay board. See Figures 1-9 thru 1-11.

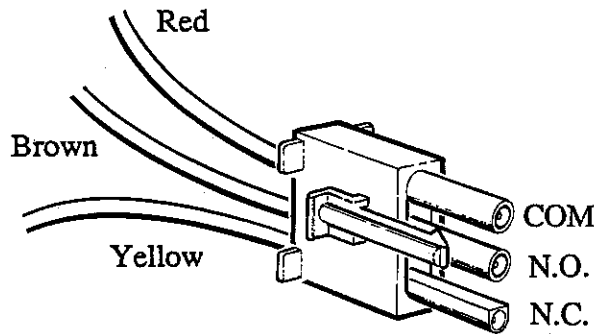

Figure 1-9. Compressor and Satellite Plug Assemblies

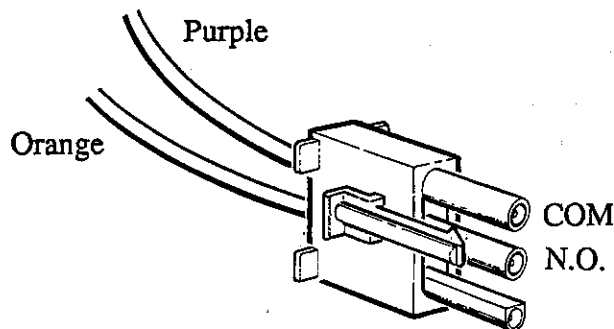

Figure 1-10. Alarm Plug Assembly

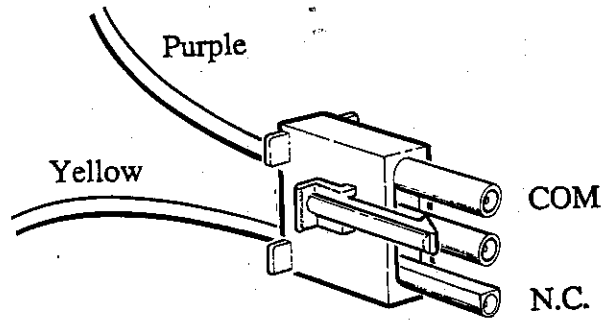

Figure 1-11. Switchback Plug Assembly

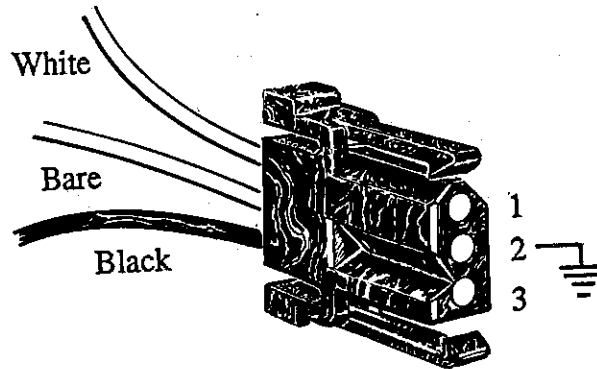

Figure 1-12. 24V AC Power Plug Assembly

### Interconnect Cable

The interconnect cable provides a signal and power pathway from the EPC-2000 to the terminal and relay boards. See Figure 1-13.

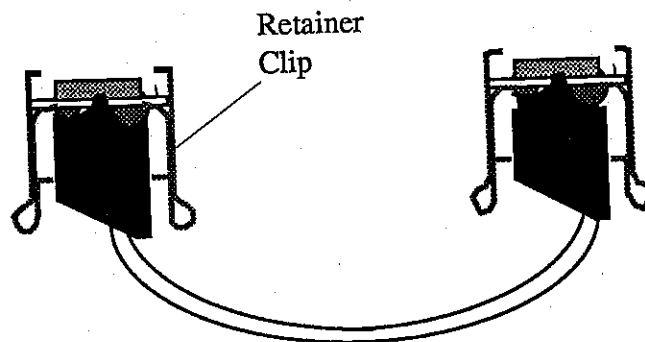

Figure 1-13. 25 Pin Interconnect Cable (Relay or Terminal Board)



## **INSTALLATION**

### **GENERAL**

This section covers both factory and field installed EPC-2000 on Super Plus Systems.

**NOTE:** Be sure to read these instructions carefully, make sure that all the necessary materials are available, and the procedures are understood in order to minimize unit downtime.

This section will describe the wiring which has been completed at the factory and the wiring which must be completed in the field. Super Plus Wiring Diagrams are included at the end of this section for reference. In addition, a startup sequence is included for the EPC-2000.

### **FACTORY INSTALLED EPC-2000**

The EPC-2000 is mounted on the left-hand door of the Super Plus System. The transformer, relay board, and input terminal board are mounted inside the panel directly behind the EPC-2000. The pressure transducer has been mounted on the suction header. All wiring integral to the control panel is completed at the factory. This includes the 24V interconnect cables, and input terminal board connections (except case Satellite and suction pressure reset temperature sensors which must be field wired to the EPC-2000 terminal board in the refrigeration control panel).

The specific components are wired as follows:

#### **EPC-2000 Transformer**

The transformer is a multi-tap transformer. The 120V primary connections are connected to terminals X1C (through fuse F10) and X21 in the control panel. The unused 208 and 240V primary wires have been insulated. The 24V AC is connected to the EPC processor assembly via the 24V AC power plug assembly. The bare ground wire is connected to the panel liner.

#### **EPC-2000 Alarm Relay**

The alarm relay (CR10) on the relay board is connected to terminal Y1 and terminal Y2 of the TDU control panel via the alarm plug assembly.

#### **EPC-2000 Switchback Relay**

The switchback relay (CR9) on the relay board is connected to terminal X1C and terminal 2 of the TDU relay in the control panel via the switchback plug assembly.

#### **Compressor Control Relays**

The compressor control relays (CR1 through CR8) on the relay board are connected to terminals 4#, 5#, and C# in the control panel via the compressor plug assembly. The # sign refers to the compressor number and the terminal block number. For example, compressor number 2 would wire into terminals 42, 52, and C2. Make sure the normally open (N.O.) contact is connected to 4#, the normally closed (N.C.) contact is connected to C#, and the common (C) is connected to 5#.

**Defrost Input**

The defrost input on the input terminal board is connected to terminals 1 and 3 of the KR relay in the control panel using Belden 8760 cable. The ground (drain) wire is connected to the panel liner at the input terminal board.

**Heat Reclaim Input**

The heat reclaim input (if so equipped) on the input terminal board is connected to terminals 4 and 6 of the HR relay in the control panel using Belden 8760 cable. The ground (drain) wire is connected to the panel liner at the input terminal.

**Factory Installed Satellite Compressor**

If a factory installed satellite(s) is included, the compressor control relay (CR7 and CR8 for satellites 1 and 2 respectively) on the relay board is connected to terminal SR, SY, and B\_ in the control panel via the compressor plug assembly. The blank "\_" following the number designates the actual defrost system number determined from the store legend.

**Temperature Sensors**

Case temperature sensors for satellites or suction pressure reset are either factory installed or field installed based on the customer's preference. Mount the field installed sensor(s) as shown in the case installation/service instructions for the particular case being controlled.

Attach the temperature sensor to Belden 8618 or equivalent cable. Extend the temperature sensor cable back to the Super Plus control panel. Do not allow the sensor cable to be grouped with high voltage wiring. Keep the sensor wiring segregated from the power wiring on long runs of adjacent cases where case raceways form a long duct prior to exiting into the floor conduits. Attach the cable wires to the terminals marked satellite temperature or suction pressure reset on the input terminal board. Also attach the ground (drain) wire to the panel liner.

**Pressure Transducer**

The suction pressure transducer is mounted on the suction header. Three-conductor cable (Belden 8618 or equivalent) is run to the input terminal board. This cable is not to be run in conduit with high voltage wiring. It is a low voltage signal circuit and need not be in conduit. The Red wire is connected to the "+15V"; the Black wire to "COM", and the White wire to "IN" on the input terminal board marked suction pressure.

This concludes the wiring for a factory installed EPC-2000. Proceed to the EPC-2000 startup and checkout procedure following.

**FIELD INSTALLED EPC-2000**

On field installed units, the following EPC-2000 components will be preassembled in a sheet metal enclosure. See Figure 2-1: EPC-2000 processor assemble, relay board, input terminal board and control transformer.

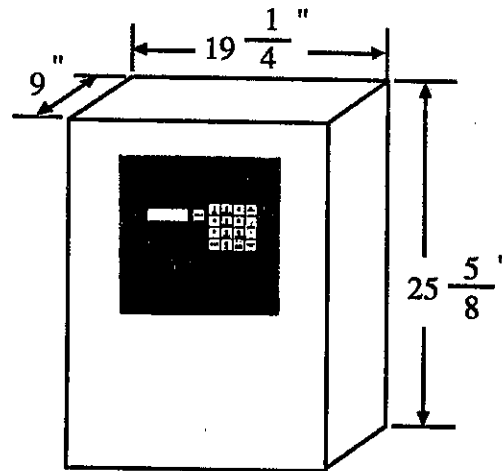

Figure 2-1. Sheet Metal Enclosure

### Materials

The following materials must be supplied by the installer:

1. Four 5/16" lag bolts or four #20 wood screws (as required)
2. 1" diameter solid or flex conduit of sufficient length to reach from the EPC-2000 to the Super Plus control panel
3. 18 AWG stranded copper wire with 600 volt insulation
4. Wire markers or tags
5. Insulated butt splice wire connectors
6. Belden 8618 (or equivalent)
7. Belden 8760 (or equivalent)
8. Wire ties
9. Refrigerant thread sealant

### Tools

Digital Multimeter, AC-DC Voltmeter, 0-480V AC minimum with Ohmmeter function (used to measure resistance and continuity)

**WARNING**

Exercise caution against inadvertent panel shorts and shock hazard when working with the Super Plus panel doors open.

**Pre-Installation**

1. Unpack the field installed EPC-2000 assembly and check for damaged or missing parts.
2. Mount the EPC-2000 assembly to the wall nearest to the Super Plus System to be controlled. The top of the enclosure should be approximately 4 feet off the floor with a minimum of 3 feet clearance in front. The wall surface should be flat so that the enclosure can be securely fastened without distorting the enclosure. Use 5/16" lag bolts or #20 wood screws (as required) with washers in each corner of the enclosure. Make sure the enclosure has not been warped and the door swings freely.
3. Install a 1" diameter piece of solid or flex conduit between the EPC-2000 assembly and the Super Plus panel. Use the box assembly knockouts located on the Super Plus panel's lower right-hand side and bottom for conduit connection.

**Installation**

Pull the appropriate number of 18 AWG 600V stranded wires through the conduit for connection to the relay board plug assemblies. Three wires are required for each compressor or satellite relay, 2 wires for the switchback relay, 2 wires for the alarm relay, and 2 wires for line voltage supply to the EPC-2000 transformer. For example: 4 compressors, 1 satellite, alarm, switchback, and power will require 21 separate wires. Label both ends of the wires for easy identification.

Before proceeding any further, open the main disconnect and control panel circuit breaker to the Super Plus System.

**WARNING**

Complete the following with all power turned off to the rack.  
This also applies to any remote satellite to be controlled by the EPC-2000.

Once the wires have been pulled, connect the labeled wires to the terminal blocks in the Super Plus control panel for each compressor or satellite, the switchback relay, the alarm relay and the transformer. These connections are described above in the factory installed sub-sections. Use the appropriate transformer primary taps 120/208/240 for the control circuit voltage for the rack on which the EPC-2000 is installed. Utilize the butt splice connectors to join the 18 AWG wire to the control circuit plug assemblies.

Pull the appropriate type cable for the defrost input (as described on Page 2-2), heat reclaim input, temperature sensor, and pressure transducer. Follow the instructions above in the factory installed sub-sections. Make the connections at the input or sensor and at the input terminal board.

This concludes the wiring for a field installed EPC-2000. Proceed to the EPC-2000 Startup and Checkout Procedure.



## STARTUP

Complete the following sequence to startup the Super Plus System:

Carefully check all wiring before startup. Check the interconnect cables to insure they are properly seated into the EPC-2000 processor assembly, the relay board, and input terminal board.

1. Turn off the individual compressor branch switches. Unplug the 24V AC power plug assembly from the side of the EPC-2000 processor assembly.
2. Close the Super Plus System main disconnect
3. Close the Super Plus System control circuit breaker
4. Using a digital multimeter, verify 24V AC secondary supply across terminals 1 and 3 of the power plug assembly (Figure 1-12). If the power supply is 21-30V AC, connect power plug assembly into the 24V AC connection on side of processor assembly. When the EPC-2000 is first powered up, the initial display will appear as shown in Figure 3-2.

## CHECKOUT PROCEDURE



**NOTE:** To complete the remaining steps of the startup procedure, you must be familiar with Section 3, Operation.

1. Check EPC-2000 factory setup. Factory setup can be reviewed using the SYSTEM MENU.
2. Turn on the compressor branch switches.
3. Observe that the EPC-2000 begins to sequence compressors.
4. Verify that the suction pressure and any case temperature probes are operating correctly.
5. Force all connected compressors and satellites individually ON and OFF using the passcode 71962 to enter the MAINTENANCE MENU.
6. Place the rack in switchback by use of the MAINTENANCE MENU to check that the low pressure controls and satellite thermostats are operational and adjusted.
7. Return the EPC-2000 to controlling the rack by resetting EPC-2000 in MAINTENANCE MENU.
8. Place a KOOLGAS system into defrost and observe that the EPC-2000 defrost screen shows ON status. Terminate the defrost and verify that the status screen changes to OFF (STATUS MENU).
9. Unplug the 25 PIN interconnect cable from the EPC-2000 relay board and make sure the refrigeration rack alarm is activated. This should also cause switchback to occur immediately.
10. Return the EPC-2000 to controlling the rack.



If any problems are detected, go to Section 4, Service (Trouble Shooting).

**OPERATION**

**KEYPAD FUNCTIONAL DESCRIPTION**

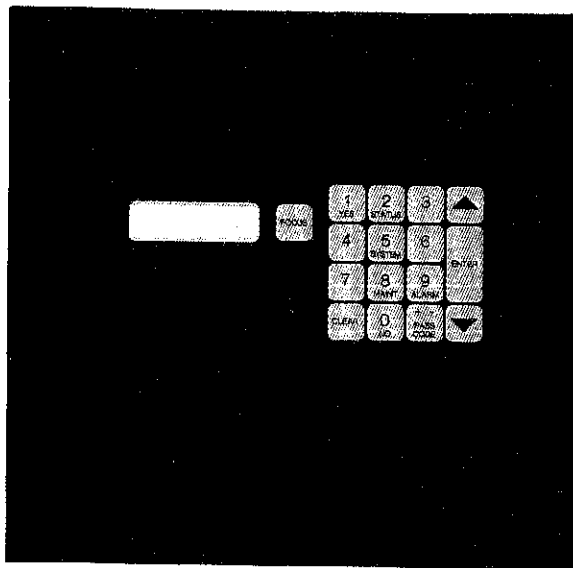

Figure 3-1. EPC-2000 Faceplate

The keypad consists of:

- A display FOCUS key, allowing the intensity of the display to be enhanced for varying viewing angles



- NUMERICAL keys from 0 to 9

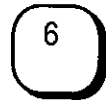

- Scroll UP and scroll DOWN keys

The up and down arrow keys, which only operate within a menu, allow a user to scroll through the information within that menu. When the last screen of a particular menu is reached, the controller will revolve back to the top of the menu. Within all but one menu, **ALARM**, the display can be scrolled forward or backward one screen at a time. If the up arrow is pressed in the **ALARM** Menu, the display will revert to the top of the menu. The down arrow scrolls through the alarms in chronological order.



- An ENTER key

Any time information needs to be changed within the processor, the ENTER key must follow the change in information for the processor to recognize the change or the entering of that information into the system. If no information is being changed, pressing the ENTER key will prompt you to exit the menu and return to the initial display.

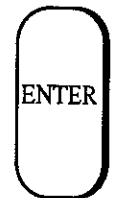

- A PASSCODE key



- A CLEAR key



- And 7 keys that have a secondary function, 4 of which are used to access the MENUS available

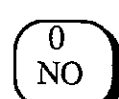

Four menus are available: **STATUS**, **MAINTENANCE**, **SYSTEM**, and **ALARM**. These menus contain information pertaining to the operation of the controller. Some of the menus require special passcodes for access. See the Passcode System Section for further information on the types of passcodes.

The display has a blue backlight that will flash in all EPC-2000 initiated alarm conditions.

The backlight turns off after 30 minutes of no user activity. Also, if the backlight is off upon entering the machine room, this is not an indication that the unit is inoperative – it is waiting for user inquiry.

**NOTE:** Anytime within a menu when the keypad is not used for 90 seconds the processor will automatically exit and return to the initial display.

### POWERING UP THE SYSTEM

When the system is first powered up the display will read:

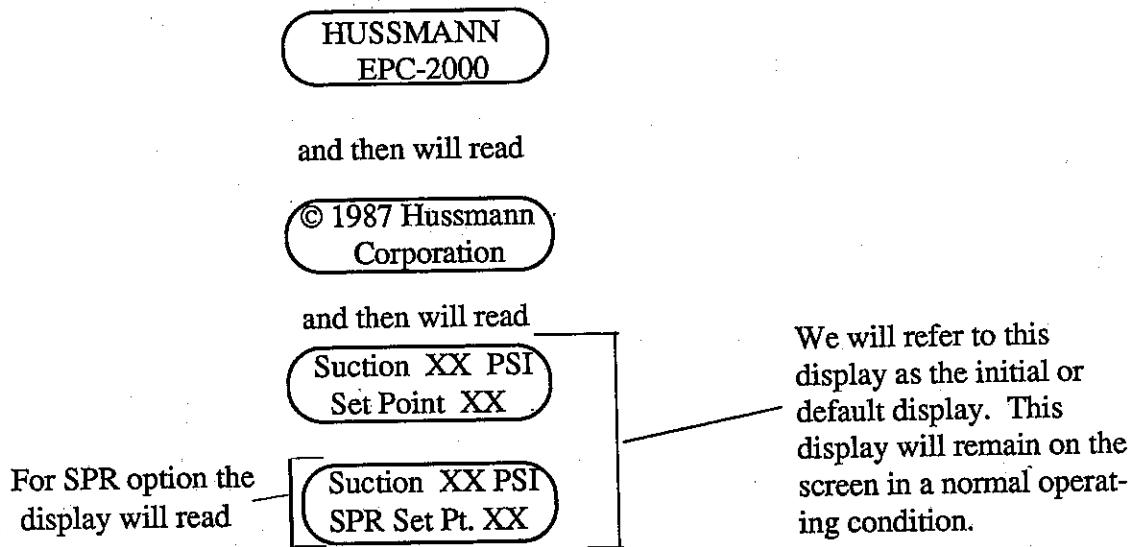

Figure 3-2. Initial Display

### THE TIME AND DATE DISPLAY

It is possible to have the time and date show continually on the display. This is done by pressing the **STATUS** key when the initial display is on the screen. The time and date will be displayed within 3 seconds and continue until other information is requested. Refer to the alarm section for setting the clock.

### PASSCODES

The controller's basic functions can be monitored at any time through the **STATUS MENU**. This menu does not require a **PASSCODE** for access.

To allow access to set points and other information by authorized people, there are **USER** and **MAINTENANCE PASSCODES**.

### User Passcode

The first type of passcode is a **USER PASSCODE**. This passcode number can be from 1 to 6 digits. It can be determined by the user and is entered into the controller by using the procedure described later in the **ENTERING PASSCODES** section. ("0" by itself cannot be used as a **USER** passcode.) A **USER** passcode gives access to the **SYSTEM MENU** and the **ALARM MENU**. Operational set points can be changed, but factory set points can only be observed.

### Maintenance Passcode

The second type of passcode is a **MAINTENANCE PASSCODE**. This passcode is preset into the controller. The 5 digit code is **71962** and cannot be changed. This passcode allows the access to the **MAINTENANCE MENU** in addition to the system and alarm menus and will allow maintenance personnel to change the functions of the system if needed for maintenance purposes such as: forcing specific compressors on and off, forcing switchback, resetting the controller, etc. See the Section on the **MAINTENANCE MENU**.

<b>LIST YOUR PASSCODE HERE FOR EASY REFERENCE</b>	
USER PASSCODE _____	
MAINTENANCE PASSCODE	<b>71962</b>

## ENTERING PASSCODES

### User Passcode

DESCRIPTION  
OF FUNCTION

PRESS  
THIS  
KEY

THIS  
WILL  
DISPLAY

Initial  
Display

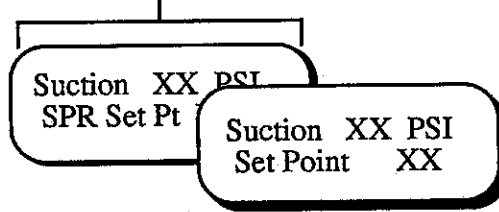

Press **PASSCODE**  
to get into routine to  
set the passcode



Press the digits  
of the passcode





DESCRIPTION OF FUNCTION	PRESS THIS KEY	THIS WILL DISPLAY
----------------------------	----------------------	-------------------------

Press ENTER and get access to the **ALARM** or **SYSTEM** menu



**NOTE:** If an incorrect passcode is entered, access is denied and the EPC-2000 returns to the initial display.

**Maintenance Passcode**

Initial  
Display

SPR OPTION  
ONLY

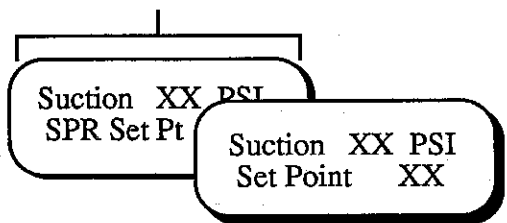

Press **PASSCODE**  
to get into routine to  
set the passcode



Press the five  
digits of the  
passcode



Press **ENTER**  
and get access to the  
**MAINT.**, **ALARM**,  
or **SYSTEM** menu



**Setting New USER passcode**

Setting a new **USER** passcode can be accomplished as shown in the following steps. After you have entered the desired digits for the passcode, the EPC-2000 will ask you for confirmation. You must enter the passcode digits again. Upon correct entry, you will get access to either the **ALARM** or **SYSTEM** MENUS.

DESCRIPTION  
OF FUNCTION

PRESS  
THIS  
KEY

THIS  
WILL  
DISPLAY

SPR OPTION  
ONLY

Initial Display

Suction XX PSI  
SPR Set Pt

Suction XX PSI  
Set Point XX

Press PASSCODE  
to get into routine to  
set the passcode

+ -  
PASS  
CODE

Enter Passcode  
0

Enter the MAINTENANCE  
passcode

Enter Passcode  
71962

**NOTE:** You cannot return to the top level until the new  
passcode is successfully entered and verified.

Press ENTER

ENTER

Press MAINT  
ALARM, or SYSTEM

Press PASSCODE  
to set new USER  
passcode

+ -  
PASS  
CODE

Set New Passcode  
New Code 000000

New passcode can  
be up to six digits

3

Set New Passcode  
New Code 3

Enter the USER  
PASSCODE

ENTER

Enter Passcode  
0

The controller  
tests for the correct  
passcode

3

Enter Passcode  
000003

Press ENTER and get  
access to the ALARM  
or SYSTEM menu

ENTER

Press  
ALARM, or SYSTEM

**End of Entering Passcodes**

**STATUS MENU**

**DESCRIPTION  
 OF FUNCTION**

**PRESS  
 THIS  
 KEY**

**THIS  
 WILL  
 DISPLAY**

SPR OPTION  
 ONLY

Initial  
 Display

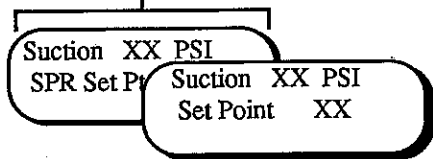

Pressing the STATUS  
 key will access the  
 STATUS MENU.



Pressing the down  
 scroll will show next  
 window and indicate  
 what set points are  
 programmed into  
 processor or the  
 actual reading that is  
 occurring at that time in  
 the system.

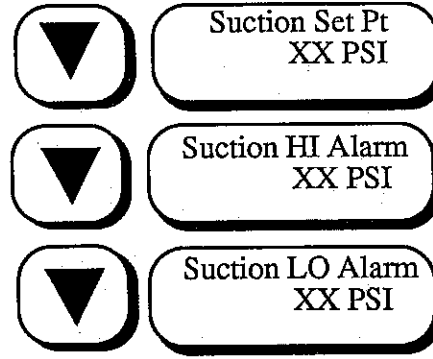



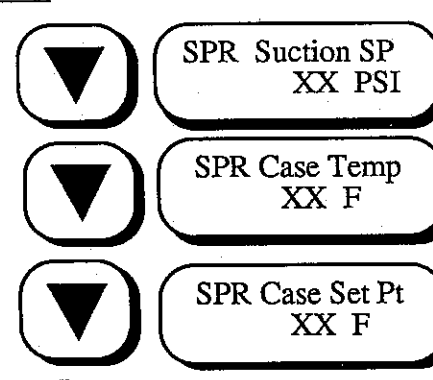



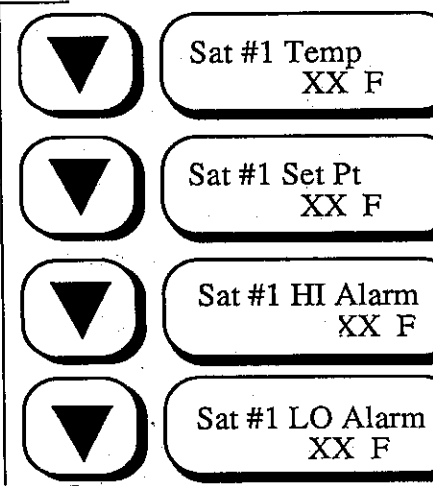

Optional Suction  
 Pressure Reset (SPR)



Optional  
 Satellite



DESCRIPTION OF FUNCTION	PRESS THIS KEY	THIS WILL DISPLAY
Optional Satellite		Sat #2 Temp XX F
		Sat #2 Set Pt XX F
		Sat #2 HI Alarm XX F
		Sat #2 LO Alarm XX F
Compressors which are off are indicated by dots.		Compressor ON 1 . . 4 . . 7 8
If defrost is on, the low suction pressure alarm is disabled. During defrost the last compressor will not be allowed to cycle off.		Defrost Status OFF
		Heat Reclaim Status OFF
		Not In Switchback
		Version No.X.XX Y

This is the end of the STATUS MENU.  
To leave the menu, press ENTER and answer the prompt with 1=YES.

**MAINTENANCE MENU**

DESCRIPTION  
 OF FUNCTION

PRESS  
 THIS  
 KEY THIS  
 WILL  
 DISPLAY

SPR OPTION  
 ONLY

Initial  
 Display

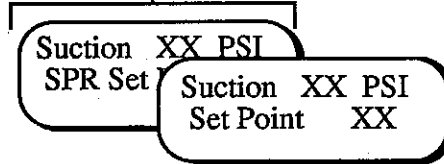

Enter the MAINTENANCE PASSCODE

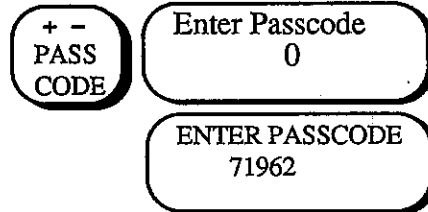

After a 3 second delay, the first screen will appear

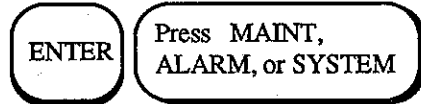

This display only appears if compressor(s) have been forced ON or OFF



**NOTE:** If you are forcing particular compressors on or off, the controller initially makes you ENTER the compressor number. After the compressor has been forced on or off the controller will ask if you would like to DO ANOTHER ONE?

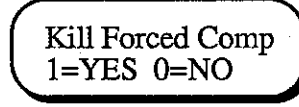

If  
 Satellite  
 Option

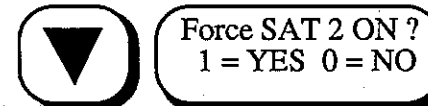
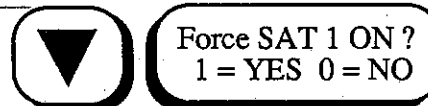

**NOTE:** Once a compressor has been forced on or off, return to KILL FORCED COMP display and answer YES before proceeding to remainder of menu.



If  
 Satellite  
 Option

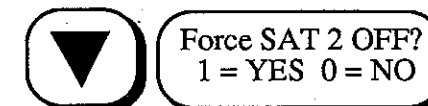
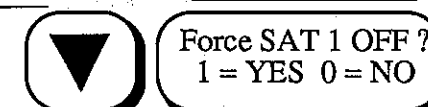

DESCRIPTION  
OF FUNCTION

PRESS  
THIS  
KEY

THIS  
WILL  
DISPLAY

**NOTE:** If you have told the controller to sequence the compressors – the controller will then tell you to press ENTER to stop.

**NOTE:** All forced functions terminate after 30 minutes with the exception of switchback which stays active until the processor is reset.

Run time meters. You read only as many meters as you have compressors.

If Satellite  
Option

Provides means to  
reset the run meters

This is the end of the  
**MAINTENANCE  
MENU.**



Seq Compressors  
1=Yes 0=No



Force SWITCH BK  
1=ON 0=OFF



Reset EPC-2000  
1=Yes 0=No



Comp #Y Run Time  
XX Hours

Sat 1 Run Time  
XX Hours

Sat 2 Run Time  
XX Hours



CLR COMP?  
1 = YES 0 = NO



Zero Suction PRS  
1=YES 0=NO



Force ON 0  
Compressor #

**NOTE:** The display will revolve until you press ENTER to leave the menu.

**SYSTEM MENU**

DESCRIPTION  
 OF FUNCTION

PRESS  
 THIS  
 KEY

THIS  
 WILL  
 DISPLAY

SPR OPTION  
 ONLY

Initial  
 Display

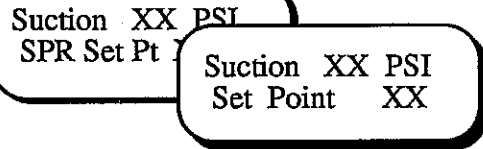

Enter the appropriate  
 PASSCODE



Follow steps to enter the  
 appropriate PASSCODE

Press the  
 SYSTEM key  
 After a 3 second delay  
 the first screen will  
 appear. Suction Set  
 Point can be adjusted  
 +10, -5 PSI from  
 default settings. See  
 Factory Setup in Section 4.



Press the down scroll  
 to view the next  
 screen of this menu.



SPR  
 Option



If Satellite  
 #1 Option

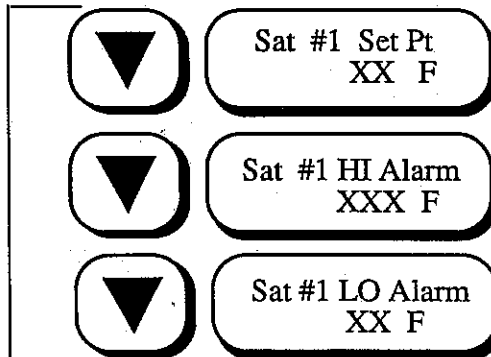

DESCRIPTION  
 OF FUNCTION

PRESS  
 THIS  
 KEY

THIS  
 WILL  
 DISPLAY

If Satellite #2  
 Option

▼	Sat #2 Set Pt XX F
▼	Sat #2 HI Alarm XXX F
▼	Sat #2 LO Alarm XX F
▼	EPC Station XX no.
▼	Baud Rate 1200 1=Yes 0=No
▼	Show Fact Set Up? 1=YES 0=NO

At this point, you have the ability to view the factory setup of the system's controller, if you choose YES. If you choose NO, you will return to the top of the SYSTEM MENU. If you need to change the factory setup, see Section 4—Configuration.



### ALARM MENU

In an alarm situation the following sequence should be initiated to turn off the alarm and read the processor for the information.

DESCRIPTION OF FUNCTION	PRESS THIS KEY	THIS WILL DISPLAY
Initial Display: constant beeping, backlight flashing.		Suction XX PSI SOFT SWITCHBACK
Press PASSCODE to get into routine to set passcode.	+ - PASS CODE	Enter Passcode 0
<b>NOTE:</b> Beeping will stop, flashing continues.	3	Enter Passcode 3
Press the digit(s) of the PASSCODE	ENTER	Press ALARM, or SYSTEM
Press ENTER	9 ALARM	Turn Alarm OFF 1=Yes 0=No
Press the ALARM key to initiate the ALARM menu.	1 YES	SET CLOCK ? 1 = YES 0 = NO
Press YES to turn the ALARM off. The backlight will stop flashing.	▼	Suction Pressure is too HIGH
If YES then go to Setting the Clock.	▼	Logged time at HH:MM MM/DD/YY
Down scroll key will indicate past alarm history *		End of Alarms!
Press Enter at any time during any menu to prompt LEAVE MENU?	ENTER	Leave Menu? 1=Yes 0=No
Press #1 to go back to initial display.	SPR OPTION ONLY	Suction XX PSI Set Point XX

\* See Table 3-2 for list of alarms

**Setting the Clock**

DESCRIPTION OF FUNCTION	PRESS THIS KEY	THIS WILL DISPLAY
From the initial display enter the USER or MAINTENANCE passcode.	ENTER	Enter Passcode 0
Select the Alarm menu.	ENTER	Press MAINT ALARM, or SYSTEM
After 3 seconds, the display will read		SET CLOCK ? 1 = YES 0 = NO
Press YES	1 YES	Time Date HH:MM MM/DD/YY
Use numeric keys to input proper time and date	7	
NOTE: After pressing a numeric key, the key cursor advances to the next field. The arrow keys may be used to select fields.	▲	Previous Field
	▼	Next Field
After proper time and date have been entered, press ENTER to set the clock.	ENTER	Clock Set to HH: MM MM/DD/YY
Press ENTER again to leave the menu.	ENTER	Leave Menu? 1=Yes 0=No
Press YES	1 YES	
Enter the STATUS menu and check for proper time and date display.		

This is the end of the ALARM menu.

**EPC-2000 Alarm System**

The EPC-2000 is equipped with an extensive alarm system designed to notify service personnel of a refrigeration problem. For several alarm situations, the EPC-2000 will transfer control to the backup mechanical pressure and temperature controls.

Table 3-1 addresses the alarms which are generated because the EPC-2000 has detected a refrigeration condition which is causing reduced system performance. Typically these alarms will be a result of a rack malfunction.

Table 3-2 lists the alarms associated with EPC-2000 self diagnostics. These alarms would generally indicate an EPC-2000 malfunction.

Column 1 of Tables 3-1 and 3-2 lists the alarm message that will be logged in the alarm menu. Column 2 lists the action that will be taken by the EPC-2000 based on the alarm. Possible causes and solutions to the specific alarm are tabulated in columns 3 and 4, respectively.

TABLE 3-1. SYSTEM ALARMS

ALARM LOG MESSAGE	EPC-2000 ACTIONS	POSSIBLE CAUSE	SOLUTION
Suction pressure is too HIGH	Rack alarm and switchback will occur if the suction pressure reading stays above the alarm limit setpoint for 60 minutes	<ul style="list-style-type: none"> <li>-Rack suction HI</li> <li>-Compressor turned OFF or failure</li> <li>-EPC-2000 suction transducer</li> </ul>	<ul style="list-style-type: none"> <li>-Check for rack problem</li> <li>-Check transducer for correct operation</li> <li>-Turn OFF alarm and reset processor</li> </ul>
Suction pressure is too LOW	Rack alarm and switchback will occur if the suction pressure reading stays below the alarm limit setpoint for 30 minutes	<ul style="list-style-type: none"> <li>-Rack suction LO</li> <li>-Compressor locked ON</li> <li>-EPC-2000 suction transducer error</li> <li>-LOW on refrigerant</li> </ul>	<ul style="list-style-type: none"> <li>-Check for rack problem</li> <li>-Check transducer for correct operation</li> <li>-Turn OFF alarm and reset processor</li> </ul>
Satellite #1 high limit reached	Rack alarm will occur if case temperature stays above alarm setpoint for 90 minutes. Switchback will not occur for this alarm parameter.	<ul style="list-style-type: none"> <li>-Control circuit switch OFF</li> <li>-Low pressure control adjusted too HIGH</li> <li>-Compressor failure</li> <li>-Defrost clock failure</li> <li>-Improper expansion valve setting</li> <li>-EPC-2000 temp. sensor error</li> </ul>	<ul style="list-style-type: none"> <li>-Check for case and rack problem</li> <li>-Check sensor for correct operation</li> <li>-Turn OFF alarm and reset processor</li> </ul>
Satellite #1 low limit reached	Rack alarm will occur if case temperature stays below alarm setpoint for 30 minutes. Switchback will not occur for this alarm parameter.	<ul style="list-style-type: none"> <li>-Compressor locked ON</li> <li>-Case thermostat adjusted below EPC-2000</li> <li>-Sat LO alarm setpoint</li> <li>-EPC-2000 temp. sensor error</li> </ul>	<ul style="list-style-type: none"> <li>-Check for rack problem</li> <li>-Check case thermostat setpoint</li> <li>-Check EPC-2000 sensor probe for correct operation</li> <li>-Turn OFF alarm and reset processor</li> </ul>

TABLE 3-1 SYSTEM ALARMS (cont.)

ALARM LOG MESSAGE	EPC-2000 ACTIONS	POSSIBLE CAUSE	SOLUTION
<p>All Compressors OFF</p>	<p>Rack alarm and switchback will occur if the EPC-2000 intelligently turns OFF all compressors for more than 60 minutes continuously. The EPC-2000 operates on a suction pressure rate and distance algorithm, thus under unusual system operational conditions all compressors could cycle off.</p>	<ul style="list-style-type: none"> <li>- Rack load reduced</li> <li>- Wrong EPC-2000 suction set point</li> <li>- EPC-2000 suction pressure transducer error</li> </ul>	<ul style="list-style-type: none"> <li>- Check rack and case operation for problems</li> <li>- Check EPC-2000 suction pressure setpoint</li> <li>- Check EPC-2000 transducer</li> <li>- Turn off alarm and reset processor</li> </ul>
<p>Defrost over 1 hour (Super Market version only)</p>	<p>Rack alarm and switchback will occur if the EPC-2000 senses that the rack is in Koolgas defrost for more than 60 minutes</p>	<ul style="list-style-type: none"> <li>- Defrost clock failed in Koolgas defrost</li> <li>- Several overlapping Koolgas defrosts</li> <li>- Panel KR relay failure</li> <li>- EPC-2000 error in reading KR relay status</li> </ul>	<ul style="list-style-type: none"> <li>- Check rack Koolgas defrost system for problems</li> <li>- Check EPC-2000 defrost inputs for correct operation</li> <li>- Turn OFF alarm and reset processor</li> </ul>

TABLE 3-2. EPC-2000 ALARMS

ALARM LOG MESSAGE	EPC-2000 ACTIONS	POSSIBLE CAUSE	SOLUTION
Time of last power up reset	Alarm and switchback will occur if power supply fails	<ul style="list-style-type: none"> <li>-Processor Reset</li> <li>-Rack control circuit turned off</li> <li>-Primary fuse/transformer failure</li> <li>-Processor 5V power supply failure</li> </ul>	<ul style="list-style-type: none"> <li>-Check primary power</li> <li>-Check transformer and fuse</li> <li>-Check processor, restore power</li> </ul>
24V DC Power Supply Failure	Alarm and switchback will occur immediately on loss of 24V DC power supply	<ul style="list-style-type: none"> <li>-Relay board(s) shorted 24V DC to ground</li> <li>-Processor Failure</li> </ul>	<ul style="list-style-type: none"> <li>-Check relay boards and interconnect cables for shorts</li> <li>-Replace processor</li> </ul>
Compressor Board failed Cable check Input Board failed Cable check	Alarm and switchback will occur within 18 seconds after sensing the loss of the interconnect cable connection to the terminal/relay board(s)	<ul style="list-style-type: none"> <li>-Relay board or terminal board interconnect cable failure</li> <li>-Poor interconnect cable connection</li> </ul>	<ul style="list-style-type: none"> <li>-Check cable indicated as a failure</li> <li>-Turn OFF alarm and reset processor</li> </ul>
EPROM Failure	Alarm and switchback will occur immediately on detection of an EPROM failure	<ul style="list-style-type: none"> <li>-Processor EPROM failure</li> </ul>	<ul style="list-style-type: none"> <li>-Replace processor</li> </ul>
EEPROM Error	Alarm and switchback will occur immediately on detection of an EEPROM failure	<ul style="list-style-type: none"> <li>-Processor EEPROM Error</li> </ul>	<ul style="list-style-type: none"> <li>-Replace processor</li> </ul>
EPC-2000 temperature exceeds 150° F	<p>Alarm will occur immediately after sensing a processor internal temperature of 150° F or greater. Switchback will not occur for this alarm.</p> <p>This alarm is a warning of an adverse operating environment, and not a response to an EPC-2000 component failure.</p>	<ul style="list-style-type: none"> <li>-Machine room ventilation failure</li> <li>-Refrigeration control panel overheating</li> <li>-EPC-2000 processor internally overheating</li> </ul>	<ul style="list-style-type: none"> <li>-Restore machine room ventilation</li> <li>-Ventilate refrigeration panel</li> <li>-Check EPC-2000 fan</li> <li>-Turn OFF alarm and reset processor</li> </ul>

## CONFIGURATION

### PURPOSE

The EPC-2000 Configuration (setup) is programmed into the processor for the specific job application prior to shipment. The configuration (setup) includes such information as type of refrigerant, number of compressors, compressor cycling routines, number of satellites, and whether various options (such as condenser fan control) are utilized. On most installations, the configuration will never have to be changed. If the need arises, however, this section is designed to allow users to reconfigure the EPC-2000 factory setup.

### CONFIGURATION PASSCODE

DESCRIPTION  
OF FUNCTION

PRESS THIS  
KEY THIS  
WILL  
DISPLAY

SPR OPTION  
ONLY

Initial Display

Suction XX PSI  
SPR Set Pt XX

Suction XX PSI  
Set Point XX

Press PASSCODE  
to get into routine to set  
the passcode.

+ -  
PASS  
CODE

Enter Passcode  
0

Press the four digits  
of the passcode.

1  
YES

Enter Passcode  
1461

### SYSTEM/CONFIGURATION MENU

Turn to the SYSTEM MENU in Section 3. Where it says enter appropriate passcode, enter the configuration passcode 1461. Proceed through all the menus shown in Section 3. When you reach the SHOW FACTORY SETUP screen, at that point return to this page for instructions.

### FACTORY SETUP

If you entered the SYSTEM MENU by using the MAINTENANCE CODE you can only view the following screens. However, if you entered by using the CONFIGURATION CODE you may make changes.

DESCRIPTION  
 OF FUNCTION

PRESS  
 THIS  
 KEY

THIS  
 WILL  
 DISPLAY

Choose Yes to continue,  
 if you choose No you will  
 return to the top of the  
 SYSTEM MENU.



Show Fact Setup?  
 1=Yes 0=No



Clear Memory?  
 1=Yes 0=No

**CAUTION**

Answering Yes to the next two screens will erase the entire configuration (factory setup).  
 User should be prepared to re-enter ALL configuration data.  
 Also, the clock will need to be reset using the ALARM MENU.

Press Yes

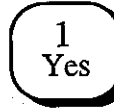

Are You Sure?  
 1=Yes 0=No

Press Yes

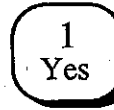

Done...No Errors

**NOTE:** It takes approximately  
 10 minutes to clear the memory. (Light dims and  
 a test screen will appear.) Answering No will  
 place you on the next screen, which is Clear  
 Alarms.

Press the down scroll



Clear Alarms?  
 1=Yes 0=No

Press Yes

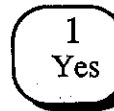

Are You Sure?  
 1=Yes 0=No



Press Yes



Are You Sure?  
 Alarms Cleared

Now press enter to exit the menu. This will place you at the initial display. You must enter the SYSTEM/CONFIGURATION MENU again. When you reach CLEAR MEMORY, press NO; CLEAR ALARMS, press NO. Answering NO to CLEAR ALARMS will place you at the next screen.

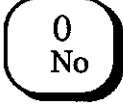



DESCRIPTION OF FUNCTION	PRESS THIS KEY	THIS WILL DISPLAY
		Clear Alarms? 1=Yes 0=No
Press No		Refrigerant R12 (Type 0,1,2) 0
Press the number corresponding to the refrigerant used.		0=R12 1=R22 2=R502
Then press ENTER. If the refrigerant is 12 just scroll down.		Spl Suct Not Inst 1=Yes 0=No

**Split Suction**

This option is sold separately. This screen tells you that Split Suction is not installed. Press Yes (Split Suction is NOT Installed) to get to the next screen.

If you have purchased this option and wish to reconfigure the factory setup to install the Split Suction Option, press NO.

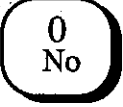
**Note:** Answering NO when the option is not available will trigger an alarm. When installing the Split Suction Option the following screens will appear twice, first to allow you to enter values for the low side (L) and again to allow you to enter values for the high side (H).



Press No		Default Suction XX PSI
Enter suction value		
Enter number of compressors		# Compressors Change to 0

**Mixmatch, Round Robin And Sequential Systems**

The next step asks if Mixmatch, Round Robin or Sequential Compressor Systems are being user defined.

Mixmatch

To enter a Mixmatch System enter the number of Mixmatch compressors.

		0-MIX #-RR 0-SEQ No. Mixmatch 0
		#-Mix 0-RR 0-SEQ Clearing Table
After a 3-second delay this screen appears		No. of Steps? 0

From this point on in Mixmatch, direction is required from Bridgeton Engineering. Below are the steps Engineering will provide.

DESCRIPTION OF FUNCTION	PRESS THIS KEY	THIS WILL DISPLAY
Enter number of steps as provided by Bridgeton Engineering.	ENTER	No. of Steps? # Clearing Table
Enter step number 01-XX as provided by Bridgeton Engineering	ENTER	Mixmatch Setup Step #01? 00
The screen will repeat until all steps have been entered	ENTER	Mixmatch Setup Step #02 00
After the last step is entered, the next screen will read:	ENTER	SPR Not Inst. 1=Yes 0=No

Round Robin and Sequential

Round Robin Systems even the runtime on compressors and Sequential cycles compressors.

		0-Mix #-RR 0-Seq No Mixmatch 0
To enter a Round Robin or Sequential System, ENTER 0 for Mixmatch compressors	0 ENTER	0-Mix #-RR 0-SEQ No. Round Robin #
For Round Robin, enter the number of compressors on which you want even runtimes	# ENTER	0-Mix #-RR 0-SEQ
For Sequential, enter 0 for Round Robin	0 ENTER	0-Mix 0-RR #-SEQ

Swing

Swing is programmed to cycle compressor #1 between the other compressors. If you install one sequential compressor and the rest round robin, you will get this screen next. Otherwise, you will go directly to the next screen.

DESCRIPTION  
 OF FUNCTION

PRESS  
 THIS  
 KEY

THIS  
 WILL  
 DISPLAY

Press the down scroll



Swing Not Inst  
 1=Yes 0=No

Press Yes  
 (answering No  
 installs Swing.)



SPR Not Inst.  
 1=Yes 0=No

**Suction Pressure Reset**

This option is sold separately.

If you wish to reconfigure the  
 Factory Setup for this option,  
 press NO to install SPR.  
 If you have not purchased  
 this option, press Yes.

SPR Not Inst.  
 1=Yes 0=No



Supermarket  
 1=Yes 0=No

EPCs are designed for  
 Supermarket or Commer-  
 cial installations. Answer  
 appropriately.



Sat #1 Not Inst  
 1=Yes 0=No

**Satellite Option**

Up to 2 satellite compressors can be controlled by the EPC-2000.

Press No to install satellite

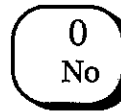

Sat #1 Not Inst  
 1=Yes 0=No

Press Yes  
 For an installed satellite,  
 temperature differential  
 can be from 1-3° F



Sat #1 Inst  
 1=Yes 0=No

Sat #1 Diff 3 F  
 Chang to (1-3) 0

Press the down scroll



Sat #2 Not Inst  
 1=Yes 0=No

Repeat for second satellite

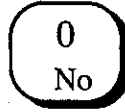

Sat #2 Inst  
 1=Yes 0=No



Sat #2 Diff 3 F  
 Change to (1-3) 0

DESCRIPTION OF FUNCTION

PRESS THIS KEY

THIS WILL DISPLAY

This feature (Receiver Level) is not available. Press Yes only



Rec Lev Not Inst  
1=Yes 0=No

This feature (KSURGE) is not available. Press Yes only



KSURGE Not Inst  
1=Yes 0=No



COND Not Inst  
1=Yes 0=No

**Condenser Fan Control Option**

This option is sold separately. This screen tells you that Condenser Fan Control option is not installed. Press Yes (Condenser Fan Control is NOT Installed) to get to the next screen. If you have purchased this option and wish to reconfigure the Factory Setup to install the Condenser Fan Control Option, press NO.

**NOTE:** Answering NO when the option is not available will trigger an alarm. When installing the Condenser Fan Control Option follow the reconfiguration steps below.

Press No to install  
Condenser Fan Control Option

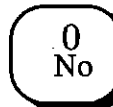

COND Not Inst  
1=Yes 0=No

COND Inst  
1=Yes 0=No

Press Yes



Select Fan Ctl  
1=Float 0=Fixed

Floating And Fixed Head Pressure

Two types of controls are available, fixed and floating head pressure. Fixed is a preset value while floating head allows the head pressure to go below the fixed head setting.

Floating Head Pressure—Press Yes to install

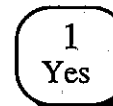

Cond Float Inst  
1=Yes 0=No

This feature (Xtra Lo Head) is not available, press Yes only



No Xtra Lo Head  
1=Yes 0=No

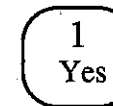

0 Cond Banks  
Change to 0

DESCRIPTION OF FUNCTION	PRESS THIS KEY	THIS WILL DISPLAY
<u>Fixed Head Pressure</u> —		Select Fan Ctl 1=Float 0=Fixed
Press No to install	0 No	Fixed Head Inst 1=Yes 0=No
Press Yes	1 Yes	Cond Fixed Inst
Press the down scroll	▼	0 Cond Banks Change to 0
Enter the number of condenser fan banks	ENTER	# Cond Banks Change to 0
Press the down scroll Answer appropriately: No will install Split Condensers	▼	SPL CON Not Inst 1=Yes 0=No
Yes will <u>not</u> install split	1 Yes	Units F PSI 1=Yes 0=No

### Units of Measurement

This screen allows you to select either °F or °C for temperature measurement and PSI or ATM for pressure.









	1 Yes	Units F PSI 1=Yes 0=No
This screen shows the EPC's internal temperature. Press the down scroll to reach the next screen	1 Yes	EPC-2000 TEMP XX F
If Condenser Fan Control Option —	▼	Outside TEMP XX F

### Zeroing

All inputs are zeroed before the EPC leaves the factory. When an input is zeroed, it should report a reading with more accuracy. Zeroing, however, doesn't guarantee a precise reading.

A pressure input may need zeroing after replacing a transducer in the field. It is not necessary, however, to zero a temperature input at any time, even if replacing a sensor.

The following screens allow you to zero the EPC's temperature and pressure inputs if desired. Answering YES to any of the screens below will enable you to zero that input. When the screen flashes the message ZEROING COMPLETE, press the down scroll to reach the next screen. Note 1 describes the procedure for zeroing a temperature (TMP) input and Note 2 describes the procedure for a pressure (PRS) input.

DESCRIPTION OF FUNCTION	PRESS THIS KEY	THIS WILL DISPLAY
		Zero SPR TMP 1=Yes 0=No
		Zero Suction Prs 1=Yes 0=No
		Zero Sat #1 TMP 1=Yes 0=No
		Zero Sat #2 TMP 1=Yes 0=No
		Zero Head TMP 1=Yes 0=No
		Zero Suction TMP 1=Yes 0=No
This is the end of the <b>SYSTEM/ CONFIGURATION MENU</b>		Zero Outside TMP 1=Yes 0=No
This screen is the top of the <b>Factory Setup Menu</b> . The screens will revolve until you press ENTER to leave the menu.		Clear Memory 1=Yes 0=No

#### NOTES

1. Zeroing Temp input is not required. To zero a temperature input for calibrations a 1731 ohm resistance must be connected across the temperature input. The existing probe must be disconnected from the input during this calibration.
2. To zero a pressure input for calibration all rack pressure on the transducer being calibrated must be removed (0 psi the transducer). The transducer should remain connected to the input during this calibration.

## CHECKOUT AND TROUBLESHOOTING PROCEDURE

This section is designed to assist servicemen in troubleshooting the EPC-2000. A step by step checkout procedure is included to isolate the cause of the malfunction.

### RECORDING INFORMATION

Upon arrival at the refrigeration rack, make a record of the following information for future reference.

- A. Rack model and serial number
- B. EPC-2000 model and serial number
- C. EPC-2000 options installed on the rack

Record the following applicable settings and present readings as shown in the **STATUS** menu.

Present suction pressure reading	_____	psi
Suction setpoint	_____	psi
Low alarm setpoint	_____	psi
High alarm setpoint	_____	psi

Koolgas defrost	_____	on/off
Heat reclaim	_____	on/off

If optional Satellite then:

Satellite temperature reading	_____	°F/C
Satellite temperature setpoint	_____	°F/C

If optional Suction Pressure Reset (SPR) then:

SPR case temperature reading	_____	°F/C
SPR case temperature setpoint	_____	°F/C
SPR setpoint	_____	psi

If an option is not installed in the EPC-2000 control, then there will not be any display screen shown for that option.

## APPARENT MALFUNCTIONS

If there are indications of recurrent problems, then proceed with this instruction and verify the complete EPC-2000 operation or identify the rack component failure.

Check the alarm log for a history of rack alarms. Note the most recent alarm entered and the time and date.

Based on your observations, proceed to Table 5-2 to determine the most likely cause. Proceed in order through the checkout procedures listed for the observation until the fault is isolated.

### WARNING

Several parts of this checkout procedure have to be performed with the power applied to the rack control circuit and the EPC-2000.  
Use caution when probing any voltage.

**NOTE:** When performing continuity and resistance checks in this procedure, make sure the circuit being tested is disconnected from any other circuits or unplugged from the EPC-2000.

### Compressor Control Circuit Test

By use of the **MAINTENANCE** menu, force **ON** each of the parallel compressors and Satellites (if installed) on the rack. Next, force **OFF** each of the compressors which was forced on in the above test.

After completing any compressor forcing function, go to the screen in the **MAINTENANCE** menu **KILL FORCED COMPRESSORS?** and answer **YES**. All compressors will turn **OFF**, then slowly cycle **ON** depending on the suction pressure requirements.

If one or more compressors do not respond then perform the following checks.

Verify that all control wiring and safety controls are correctly wired and set. Refer to Super Plus wiring diagrams Figures 2-2 and 2-3.

### Compressor Will Not Turn ON

Using the **MAINTENANCE** menu, force **ON** the suspect compressor.

Using an AC voltmeter, measure the voltage from the common connection 5# or B\_ terminal in the Super Plus control panel for the suspect compressor to X2 of the control circuit. Full control circuit voltage should be measured at this time, 120, 208, or 240V AC for example. (See Super Plus Wiring Diagrams.)



If the proper voltage is not measured, unplug the compressor plug assembly from the EPC-2000 relay board and check continuity with an ohmmeter between the COM and N.O. positions of the relay board plug socket. See Figure 5-1. There should be 0 ohms resistance between these contacts.

If there was continuity, next verify continuity of the compressor control plug assembly. See Figure 1-9. The compressor should be running if the above steps check OK. Recheck the control circuit and all safety controls. Retest.

If continuity does not exist use a DC voltmeter to measure voltage between G1 and PS1 on the relay board.

Use the tip of the voltmeter negative probe to scratch through the green solder mask to make good contact with G1. If the voltage reads 20 to 30V DC, proceed to measuring voltage between G1 and the particular diode associated with the relay, as given below. If no voltage is measured, go to the cable continuity check. In the event the voltage is below this value, go to the power supply test.

If the cable and power supply are satisfactory, replace the EPC processor assembly.

Measure the voltage between G1 (-) and the diode (+) for the particular relay being tested. The diodes are labeled D1 through D10. D1 through D6 correspond to compressor relays #1 through #6, respectively. D7 and D8 correspond to Satellite relays #1 and #2 respectively. D9 corresponds to the switchback relay and D10 corresponds to the alarm relay.

The + probe of the voltmeter must be placed on the diode lead nearest the edge of the board. See Figure 5-1.

**NOTE:** Do not short voltmeter probe between diode and adjacent resistors.

If the measured voltage is greater than 3V DC then proceed with relay board and cable continuity test. If the relay board and cable continuity check out OK, replace the EPC processor assembly. If the measured voltage is 0 to 3V DC then replace the relay board.

Compressor will not turn OFF

Using the **MAINTENANCE** menu, force the suspect compressor **OFF**.

Unplug the appropriate compressor plug assembly from the EPC-2000 relay board and check continuity with the ohmmeter between the COM and N.O. positions of the relay board plug socket. See Figure 5-1. There should be an open circuit between these contacts.

If an open circuit exists, check the compressor control plug assembly and control panel wiring for shorts. Make sure all power to the rack is turned off.

If continuity exists between COM and N.O. above, use a DC voltmeter to measure the voltage between G1 (-) and the diode (+) for the particular relay being tested above.

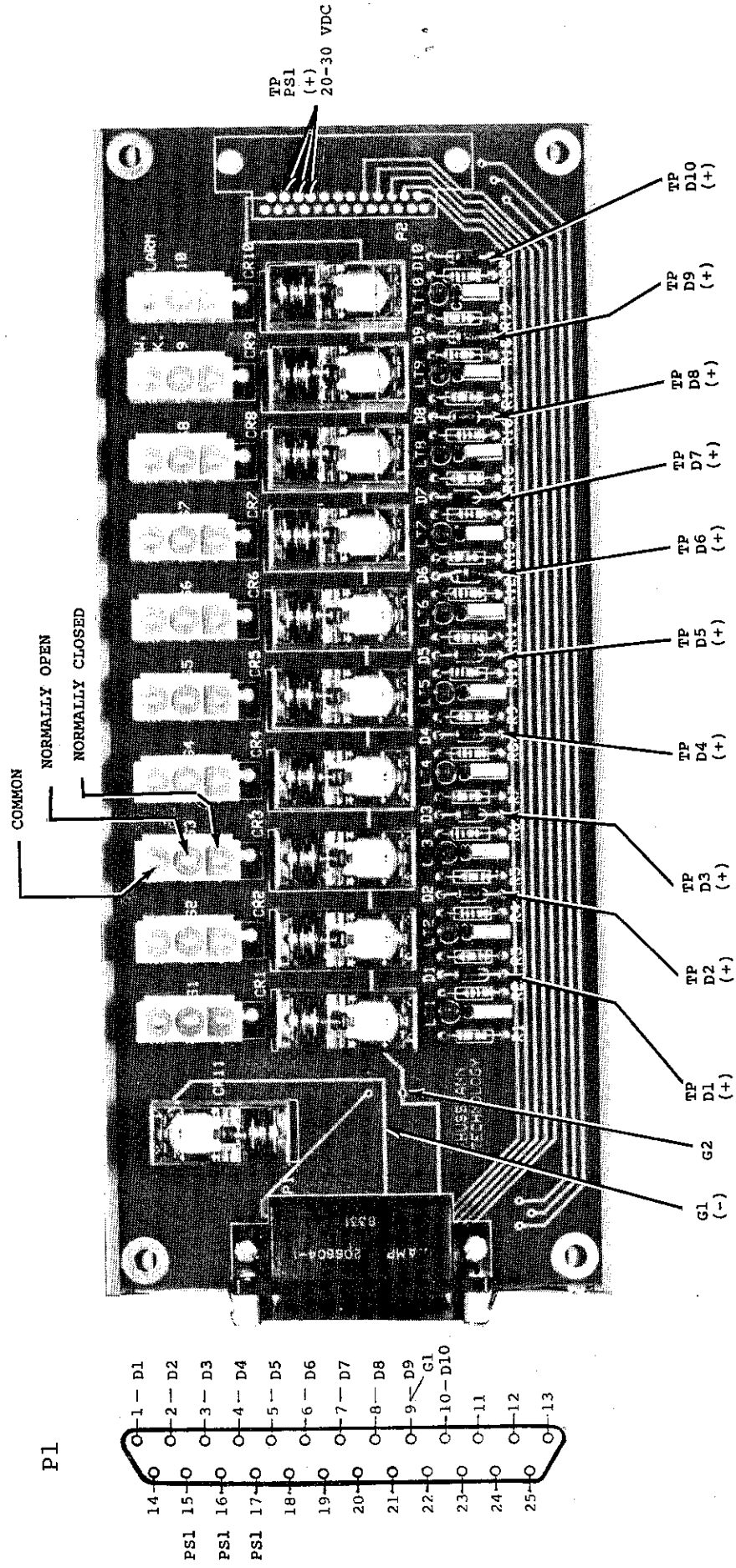

Figure 5-1. Compressor Relay Board

If the voltage is 20 to 30V DC, then replace the relay board.

If the voltage is 0 to 3V DC, proceed with the relay board and cable continuity test. If the relay board and cable checkout OK, replace the EPC processor assembly.

### **Switchback Mode Test**

If the Super Plus system appears to be stuck in either the auto mode (under EPC-2000 control) or the switchback mode (under mechanical pressure control), perform the following steps.

#### Stuck in Automatic (EPC-2000)

Force switchback using the **MAINTENANCE** menu.

Using a DC voltmeter, measure the voltage between G1 (+) and G2 (-), see Figure 5-1. The voltage measured should be 20 to 30V DC. The switchback LED and relay will be **OFF**.

If the measured voltage is 0 - 3V DC, go to the relay board and cable continuity tests. Replace the processor if no problem is seen with the relay board or cable.

If the voltage measured is correct above, then check for continuity thru the switchback COM and N.C. contacts of the relay board switchback socket S9. See Figure 5-1. Replace the relay board if an open is measured.

Check the switchback plug assembly, see Figure 1-11, for continuity and proper connections in the Super Plus control panel. The problem is in the control panel if no faults are located above.

#### Stuck in Switchback (Mechanical Pressure Controls)

Force EPC-2000 out of switchback using the **MAINTENANCE** menu.

Using a voltmeter, measure the voltage between G1 (+) and G2 (-). The voltage measured should be 0 to 3V DC. The switchback LED and relay should be **ON**. Proceed to the paragraph below if the voltage is greater than 3V DC.

Measure the continuity thru the N.C. and COM contacts of switchback socket S9. An open circuit should be measured.

Carefully check the switchback plug assembly, see Figure 1-11, for continuity and proper connections in the Super Plus control panel. The problem exists in the control panel if no faults have been located above.

If the measured voltage is 20 to 30V DC, go to the relay board and cable continuity tests. Replace the processor if no problem is seen with the relay board or cable.

**Alarm Relay Test**

To check the EPC-2000 alarm relay, a comparison between the LCD display and the relay board alarm relay status must be made. To cause the EPC-2000 to signal an alarm, unplug the terminal board cable assembly from the processor. Within 18 seconds the EPC-2000 will signal terminal board cable failure alarm and cause switchback. Complete the following steps for an observed EPC-2000 alarm failure.

**EPC-2000 Alarm Relay Will Not Signal Rack Alarm**

Observe that the EPC is signaling alarm ( flashing the backlight and the beeper is sounding as described in Section 3 of this manual.)

If the alarm relay LED indicator is **OFF**, proceed with the following continuity check, otherwise do the next check.

Using an ohmmeter, verify that there is an open circuit between the COM and N.O. contacts of relay socket S10. If an open was measured, then there is a wiring problem in the Super Plus panel control circuits preventing the signaling of the rack alarm.

If continuity exists, use a DC Voltmeter to measure voltage between PS1 (-) and D10 (+). If the measured voltage is 20 to 30V DC then replace the relay board.

If the measured voltage is 0 - 3V DC, conduct the relay board continuity test and verify that D10 is not shorted to G1 or any other pin on plug P1. Replace the relay board if found shorted.

Conduct the cable continuity test. Replace the cable if found faulty.

If the above steps have not located the problem, replace the processor.

**Alarm Relay Stuck in Alarm**

Verify that the EPC-2000 is not signaling an alarm.

Check for continuity between the N.O. and COM pins of alarm plug S10. If the resistance is 0.1 ohms or less, check the alarm circuit plug assembly and control circuit wiring. The problem exists in the panel wiring, not the EPC-2000.

Using a DC voltmeter, measure voltage from G1 (-) to D10 (+). If the voltage is 0 - 3V DC, replace the relay board. If the measured voltage is 20 - 30V DC, conduct the relay board continuity test and verify that diode D10 has continuity through to plug P1 pin 10. Replace the relay board, if a fault is found.

Conduct the 25 pin cable continuity check for the relay board cable. Replace the cable if the fault is located. Replace the processor if a fault is not found.

### Power Supply Test

The EPC-2000 is supplied with power by a multi-tap primary transformer. The primary taps are: 120/208/240V AC with a secondary output of 24V AC at full load. ~~Acceptable secondary voltage limit is 21 to 30V AC.~~

- 2) Using an AC voltmeter, verify the power transformer ~~primary and secondary voltages.~~ <sup>15 21 to 30V AC</sup>  
Replace the transformer if voltages measured are outside the specified range. ~~If primary~~ <sup>1)</sup>  
voltage is 0V AC, check panel fuse (F10) and replace with similar type rating if blown.

REF.

Unplug the 24V AC power plug from the processor and verify the secondary voltages across pins 1 and 3. If voltage is less than 21V AC, replace the power plug assembly. If the voltage is within the specified range but the EPC fails to operate when the 24V AC power plug is connected, replace the EPC processor assembly. Good continuity from pin 2 to ground (panel or box assembly liner) must exist.

### Suction Pressure Transducer And Cable Test

The suction pressure transducer used by the EPC-2000 is a 0-100 psi sealed part. See Figure 1-7. The output voltage range is 1 to 6V DC maximum.

Using a DC voltmeter, place the positive probe on +15V and the negative probe on COMMON of the suction pressure terminals on the input terminal board. See Figure 5-2. If the voltage is greater than 15.25V DC, replace the processor. If the voltage measured is less than 14.5V DC, go to the input terminal board and cable continuity tests. Replace the processor if no faults are found in continuity checks.

If the transducer is operating properly, measure the voltage from IN to COMMON. The positive probe should be on IN. The measured voltage will be proportional to the rack suction pressure. To determine the rack suction pressure, use the following equation.

$$\text{suction pressure} = (V_{in} - 1) \times 20 \quad \pm 2 \text{ psi}$$

Using a gage manifold, measure the rack suction pressure.

If the EPC-2000 readout does not match gage pressure, then compare the calculated suction pressure to gage pressure. If the two pressures are equal, then conduct the input terminal board and cable assembly continuity test. Replace the processor if the problem is not found in the input terminal board or cable assembly.

If the display matches the calculated suction pressure but is not within 2 psi of gage, replace the transducer.

### **Temperature Sensor Checkout**

The same temperature sensor (Figure 1-6 ) is used for all EPC-2000 temperature inputs. Testing and verification of all sensors will be identical except for the location of the sensor connection on the terminal board.

#### General Check

The most fundamental checkout of the temperature sensor is to place an accurately calibrated thermometer in the airstream near the sensor bulb and make a direct comparison between the reading of the thermometer and the reading on the EPC-2000.

If the readings are within 3 degrees, the sensor and other components are probably OK. If the readings are unacceptable, then the following items need to be checked to find the problem.

#### Sensor Mounting

Check to see that the entire sensor is in the air stream. Clamping the sensor to the metal wall of a flue can allow the metal wall temperature to adversely affect the temperature reading.

For cases with single air curtain passages, this has not been a problem. However, clamping the sensor onto the sheet metal divider between two-temperature air curtains can affect the temperature of the sensor. Make sure the entire sensor is within and sensing the air stream you want to measure.

#### Resistance Check

Remove the EPC-2000 temperature sensor cable from the input terminal board in the machine room. Using an accurate ohmmeter, measure the resistance of the sensor with the cable leads removed from the input terminal board. Polarity of the ohmmeter leads will not change the measurement.

Compare the ohmmeter reading to Table 5-1 below, and find an equivalent temperature value. If the resistance equivalent temperature is more than 3 degrees from the actual thermometer measurements, check the sensor and cable installation. Replace the sensor if installation is found to be correct. If the problem still exists, check input terminal board and cable continuity check section.

If the problem is not found in the above steps, replace the processor.

**Table 5-1**  
EPC-2000 Probe Checkout Table

Temperature Resistance		Temperature Resistance		Temperature Resistance	
°F	Ohms	°F	Ohms	°F	Ohms
-40	1584	5	1750	50	1927
-39	1588	6	1754	51	1931
-38	1591	7	1758	52	1935
-37	1595	8	1761	53	1939
-36	1598	9	1765	54	1943
-35	1602	10	1769	55	1947
-34	1606	11	1773	56	1951
-33	1609	12	1777	57	1955
-32	1613	13	1781	58	1959
-31	1616	14	1784	59	1963
-30	1620	15	1788	60	1967
-29	1624	16	1792	61	1971
-28	1627	17	1796	62	1975
-27	1631	18	1800	63	1980
-26	1635	19	1804	64	1984
-25	1638	20	1808	65	1988
-24	1642	21	1811	66	1992
-23	1646	22	1815	67	1996
-22	1649	23	1819	68	2000
-21	1653	24	1823	69	2004
-20	1657	25	1827	70	2008
-19	1660	26	1831	71	2012
-18	1664	27	1835	72	2017
-17	1668	28	1839	73	2021
-16	1671	29	1843	74	2025
-15	1675	30	1847	75	2029
-14	1679	31	1851	76	2034
-13	1682	32	1855	77	2038
-12	1686	33	1859	78	2042
-11	1690	34	1863	79	2046
-10	1694	35	1866	80	2050
-9	1697	36	1870		
-8	1701	37	1874		
-7	1705	38	1878		
-6	1708	39	1882		
-5	1712	40	1886		
-4	1716	41	1890		
-3	1720	42	1894		
-2	1724	43	1898		
-1	1727	44	1902		
0	1731	45	1906		
1	1735	46	1910		
2	1738	47	1914		
3	1742	48	1918		
4	1746	49	1922		

**Koolgas Relay And Heat Reclaim Relay Input Tests**

Koolgas Relay

To check the operation of the Koolgas status input, place a system in Koolgas defrost. Observe the **STATUS** menu. The defrost screen should show **ON**. Using a DC voltmeter, measure the voltage between the system's defrost input terminals on the input terminal board. The voltage measured should be 0 to 0.1V DC. If the voltage is greater than this value, check the KR relay in the control panel. Insure the proper terminals are connected.

If no voltage was measured in the above step, and the **STATUS** menu continually shows **OFF**, go to the input terminal board and cable continuity tests. Replace the processor if the problem is not found.

Next, take the system out of Koolgas defrost. The **STATUS** menu screen should now read **OFF**. Again using a DC voltmeter, measure voltage across the defrost input terminals on the input terminal board. The voltage measured should be 13.8 to 14.5V DC.

If the **STATUS** screen continues to show **ON** and the measured voltage is 0.1V DC or less when a system is not in defrost, check the KR relay in the control panel to insure the proper terminals are connected and that the KR relay is deenergised.

If the **STATUS** menu screen shows defrost **ON** when no system is in Koolgas defrost and the measured voltage across the defrost input is 13.8 to 14.5V DC, replace the EPC-2000 processor assembly.

#### Heat Reclaim Relay

To check the operation of the heat reclaim status input, conduct the same test steps as in the Koolgas input test. Substitute the heat reclaim terminals for Koolgas terminals. The voltage specifications still apply.

#### **Continuity Checks**

##### Relay Board

This test checks for proper connection of the 25 pin plug assembly P1 to the appropriate relay drive circuits.

Using an ohmmeter, verify continuity of the labeled test points on the PC board to their corresponding positions on P1. The resistance should be 0 to 0.1 ohms maximum. No adjacent pins on P1 should be shorted together. Refer to Figure 5-1 for location of testpoints on the board and their corresponding pin locations on plug 1. Replace the relay board if a problem is seen.

##### Input Terminal Board

Using an ohmmeter, check the continuity between terminal blocks P2, P3 and P4 to the 25 pin plug P1. Less than 0.1 ohms resistance should be measured between each terminal block and its corresponding P1 pin location. Replace input terminal board if fault is found. Refer to Figure 5-2.

##### Cable

To check the continuity of the 25 pin relay and input terminal board cable assemblies, each pin must be checked for connection thru to the other plug. No more than 0.1 ohms resistance should be measured from one plug pin to the other end. If resistance is greater than 0.1 ohm, then replace the cable. Check for adjacent pins being shorted together. If shorts are measured, replace the cable.



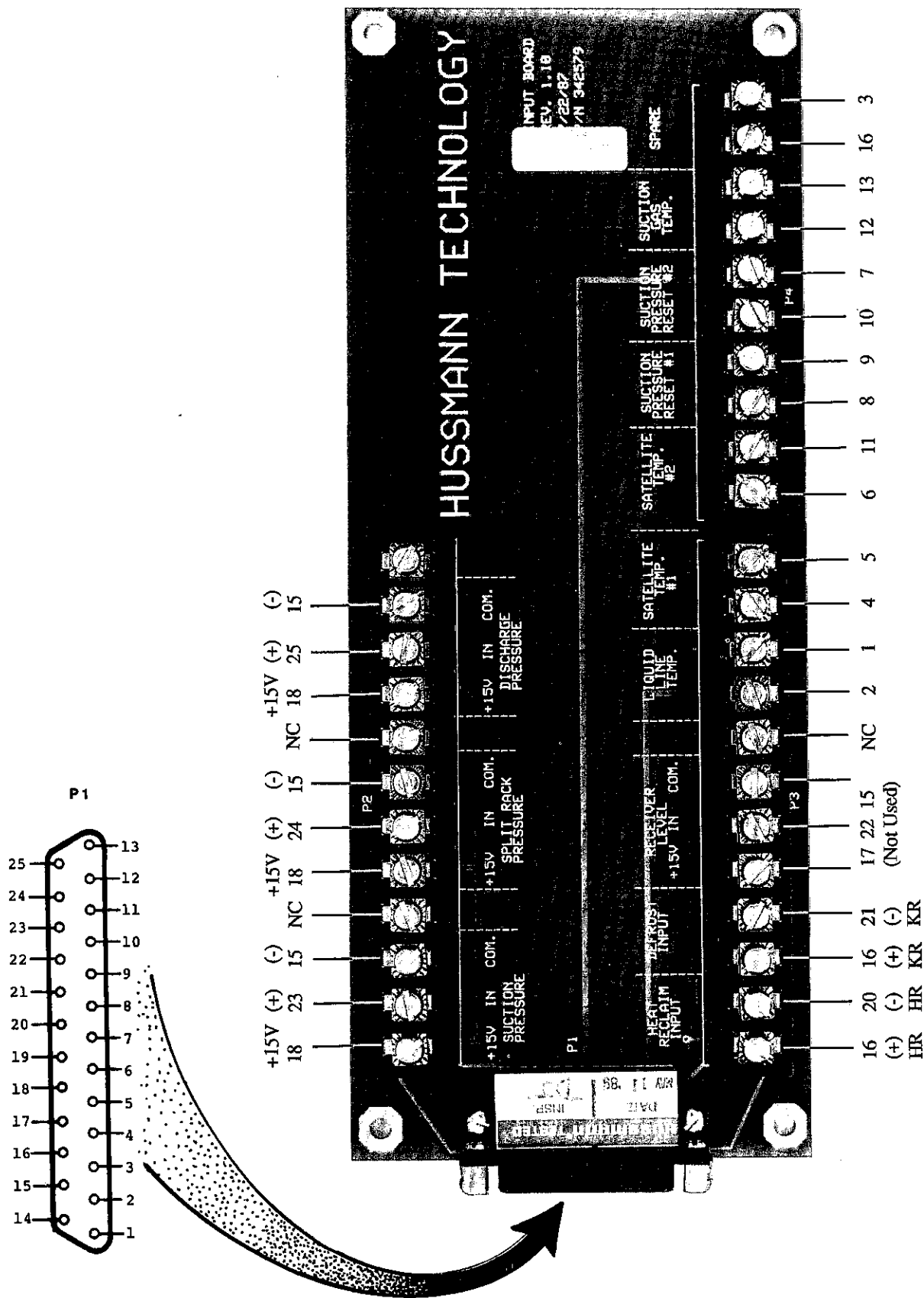

Figure 5-2. Input Terminal board

TABLE 5-2. TROUBLESHOOTING CHECKOUT PROCEDURES

OBSERVATION	PROBABLE CAUSE	CHECKOUT PROCEDURE	PAGE
Display Blank	<ul style="list-style-type: none"> <li>-Power Failure</li> <li>-Fuse Failure</li> <li>-Transformer Failure</li> <li>-24V AC Power Cable</li> <li>-Processor Failure</li> </ul>	<ul style="list-style-type: none"> <li>-Power Supply Test</li> <li>-Power Supply Test</li> <li>-Power Supply Test</li> <li>-Power Supply Test</li> </ul>	<p>5-</p> <p>7</p> <p>7</p> <p>7</p> <p>7</p>
Displayed Suction Pressure does not match gauge	<ul style="list-style-type: none"> <li>-Transducer Failure</li> <li>-Input Terminal Board Failure</li> <li>-Terminal Board Cable Failure</li> <li>-Processor Failure</li> </ul>	<ul style="list-style-type: none"> <li>-Suction Pressure Transducer and Cable Test</li> <li>-Input Terminal Board Continuity Check</li> <li>-Cable Continuity Check</li> </ul>	<p>7</p> <p>10</p> <p>10</p>
Case Temperature does not match displayed temperature	<ul style="list-style-type: none"> <li>-Temperature Sensor Failure</li> <li>-Input Terminal Board Failure</li> <li>-Terminal Board Cable Failure</li> <li>-Processor Failure</li> </ul>	<ul style="list-style-type: none"> <li>-Temperature Sensor Checkout</li> <li>-Input Terminal Board Continuity Check</li> <li>-Cable Continuity Check</li> </ul>	<p>8</p> <p>10</p> <p>10</p>
EPC-2000 "Compressors ON" indication does not match actual compressor status	<ul style="list-style-type: none"> <li>-Panel Wiring</li> <li>-Relay Board Failure</li> <li>-Relay Board Cable Failure</li> <li>-Processor Failure</li> </ul>	<ul style="list-style-type: none"> <li>-Compressor Control Circuit Test, "Compressor Will Not Turn ON" steps</li> <li>-Compressor Control Circuit Test, "Compressor Will Not Turn ON" steps, Relay Board Continuity Check</li> <li>-Cable Continuity Check</li> </ul>	<p>2</p> <p>2, 10</p> <p>10</p>
Actual compressor status does not match relay board "LED" indication	<ul style="list-style-type: none"> <li>-Panel Wiring</li> <li>-Relay Board Failure</li> </ul>	<ul style="list-style-type: none"> <li>-Compressor Control Circuit Test, "Compressor Will Not Turn ON" steps</li> <li>-Relay Board Continuity Test</li> </ul>	<p>2</p> <p>10</p>
Actual defrost status does not match EPC-2000 indication	<ul style="list-style-type: none"> <li>-Panel Wiring/Terminal Board</li> <li>-Input Terminal Board Failure</li> <li>-Terminal Board Cable Failure</li> <li>-Processor Failure</li> </ul>	<ul style="list-style-type: none"> <li>-Koolgas Relay Input Test</li> <li>-Cable Continuity Check</li> <li>-Input Terminal Board Continuity Check</li> </ul>	<p>9</p> <p>10</p> <p>10</p>

TABLE 5-2. TROUBLESHOOTING CHECKOUT PROCEDURES (cont.)

OBSERVATION	PROBABLE CAUSE	CHECKOUT PROCEDURE	PAGE
Actual heat reclaim status does not match EPC-2000 indication	<ul style="list-style-type: none"> <li>-Panel Wiring/Terminal Board</li> <li>-Terminal Board Cable Failure</li> <li>-Input Terminal Board Failure</li> </ul>	<ul style="list-style-type: none"> <li>-Heat Reclaim Relay Input Check</li> <li>-Input Terminal Board Continuity Check</li> <li>-Cable Continuity Check</li> </ul>	5- 10 10 10
Rack in alarm, EPC-2000 not in alarm	<ul style="list-style-type: none"> <li>-Panel Wiring</li> <li>-Relay Board Failure</li> <li>-Relay Board Cable Failure</li> <li>-Processor Failure</li> </ul>	<ul style="list-style-type: none"> <li>-Compressor Control Circuit, first step</li> <li>-Alarm Relay Stuck in Alarm, Relay Board Continuity</li> <li>-Cable Continuity</li> </ul>	2 6, 10 10
EPC-2000 in alarm Rack not in alarm	<ul style="list-style-type: none"> <li>-Panel Wiring</li> <li>-Relay Board Failure</li> <li>-Relay Board Cable Failure</li> <li>-Processor Failure</li> </ul>	<ul style="list-style-type: none"> <li>-Compressor Control Circuit, first step</li> <li>-Alarm Relay Will Not Signal Alarm, Relay Board Continuity</li> <li>-Cable Continuity</li> </ul>	2 6, 10 10
Rack and EPC-2000 in alarm, alarm will not reset	<ul style="list-style-type: none"> <li>-Panel Wiring</li> <li>-Relay Board Failure</li> <li>-Relay Board Cable Failure</li> <li>-Processor Failure</li> </ul>	<ul style="list-style-type: none"> <li>-Compressor Control Circuit, first step</li> <li>-Alarm Relay Stuck In Alarm, Relay Board Continuity</li> <li>-Cable Continuity Check</li> </ul>	2 6, 10 10
EPC-2000 in switchback Rack not in switchback	<ul style="list-style-type: none"> <li>-Panel Wiring/TDU</li> <li>-Relay Board Failure</li> <li>-Relay Board Cable Failure</li> <li>-Processor Failure</li> </ul>	<ul style="list-style-type: none"> <li>-Compressor Control Circuit Test, first step</li> <li>-Switchback Mode Test, "Stuck in Automatic" steps, Relay Board Continuity Check</li> <li>-Cable Continuity</li> </ul>	2 5, 10 10
EPC-2000 not in switchback Rack in switchback	<ul style="list-style-type: none"> <li>-Panel Wiring/TDU</li> <li>-Relay Board Failure</li> <li>-Relay Board Cable Failure</li> <li>-Processor Failure</li> </ul>	<ul style="list-style-type: none"> <li>-Compressor Control Circuit Test, first step</li> <li>-Switchback Mode Test, "Stuck in Switchback" steps, Relay Board Continuity Check</li> <li>-Cable Continuity</li> </ul>	2 5, 10 10

### REPLACEMENT PARTS LIST

<u>ITEM</u>	<u>PART NUMBER</u>	<u>DESCRIPTION</u>
1	0339682	EPC-20002 Compressor EPC-20003 Compressor EPC-20004 Compressor EPC-20005 Compressor EPC-20006 Compressor
2	0334493	Sat Probe EPC-2000 SPR Probe EPC-2000 Liquid Line Probe EPC-2000
3	0334482	Relay Board
4	0334492	Input Terminal Board
5	0334267	25 Pin Relay Board Cable
6	0335183	Transducer
7	0332714	Transformer
8	0335836	25 Pin Terminal Board Cable
9	0334199	24V AC Cable
10	0334198	Switchback Plug Assembly
11	0334196	Alarm Plug Assembly
12	0334197	Compressor Plug Assembly

# HUSSMANN®

## LIMITED WARRANTY

Hussmann Corporation warrants each new Hussmann EPC-2000 microprocessor based refrigeration system controller to be free from defects in material and workmanship at the time of purchase. Hussmann's obligations under this warranty shall be limited to repairing or exchanging any part or parts, without charge, F.O.B. factory or nearest authorized parts depot, which may prove defective within three (3) years from date of original installation (not to exceed thirty-nine (39) months from date of shipment from the factory) and which is proven to the satisfaction of Hussmann to be thus defective. Hussmann may at its option ship a replacement part prior to receipt of the customer's defective part upon receipt of a purchase order from the customer. Upon receipt by Hussmann of a defective part proven to Hussmann's satisfaction to be thus defective, the customer will be credited the exchange price of the part. The warranties to repair or replace above recited, are the only warranties, express, implied, or statutory, made by Hussmann with respect to the equipment, INCLUDING ANY IMPLIED WARRANTY OR MERCHANTABILITY OR FITNESS, and it neither assumes, nor authorizes any person to assume for it, any other obligations or liability in connection with the sale of said equipment or any part thereof.

THIS WARRANTY SHALL NOT APPLY TO LOSS OF FOOD OR INCREASED POWER CONSUMPTION OR INCREASED UTILITY CHARGES DUE TO FAILURE FOR ANY REASON.

Hussmann SHALL NOT BE LIABLE for any repairs or replacements made by buyer without the written consent of Hussmann, or when the equipment is installed or operated in a manner contrary to the printed instructions covering installation and service which accompanied the equipment nor for payment of any removal or installation charges of warranted parts.

Hussmann SHALL NOT BE LIABLE for any damages, delays, or losses, direct or consequential, caused by defects, nor for damages caused by short or reduced supply of materials, fire, flood, strikes, acts of God, or circumstances beyond its control or when the failure or defect of any part or parts is incident to ordinary wear, accident, abuse or misuse, or when the serial number of the equipment has been removed, defaced, altered, or tampered with.

Said warranty shall be void when this equipment is operated on low or improper voltages, or is put to a use other than normally recommended by Hussmann or when the equipment is moved to a different address other than the original installation.

## HUSSMANN®

A Whitman Company

© Copyright, 1989 by Hussmann Corporation. All rights reserved. This work shall not be reproduced in whole or in part without expressed written permission.

*Quality That Sets Industry Standards*