

Second Nature Medium Temperature Secondary Refrigeration Installation Manual

SECOND^o NATURE[®]

Secondary Coolant System Installation, Testing, and Start-Up Specifications

Revision 7.1 — Replaces Revision 6

January 2010



Produced by the Hill PHOENIX Learning Center

We give you more than solutions — we give you answers.

Hill PHOENIX
EXCELLENCE

© 2010 Hill PHOENIX

Preface to this Hill PHOENIX Manual

Several refinements have been made since prior versions of these “Secondary Coolant System Installation, Testing, and Start-Up Specifications” manual. Information from field installations, contractors, and customers has proven valuable and has been included in this manual. This manual contains many changes most notably regarding the following topics:

- Piping Guidelines – additional piping details for air removal, drainage, revised valving details for case line-ups and walk-ins
- Insulation Sizing – expanded ambient conditions and applications
- Second Nature Medium Temp Start-Up Chart and Hill PHOENIX Warranty Validation Checklist

DISCLAIMER

This manual is designed to provide only general information. If you need advice about a particular product application or installation, you should consult your Hill PHOENIX Representative. The applicable specification sheets, data sheets, handbooks, and instructions for Hill PHOENIX products should be consulted for information about that product, including, without limitation, information regarding the design, installation, maintenance, care, warnings relating to, and proper uses of each Hill PHOENIX product.

INFORMATION CONTAINED WITHIN THIS MANUAL, IS PROVIDED "AS IS," WITH ALL FAULTS, WITH NO REPRESENTATIONS OR WARRANTIES OF ANY KIND, EITHER EXPRESSED OR IMPLIED, INCLUDING, BUT NOT LIMITED TO, THE IMPLIED WARRANTIES OF MERCHANTABILITY, FITNESS FOR A PARTICULAR PURPOSE, QUALITY OF INFORMATION, QUIET ENJOYMENT, AND TITLE/NONINFRINGEMENT. HILL PHOENIX SPECIFICALLY DISCLAIMS ALL LIABILITY FOR ERRORS OR OMISSIONS IN, OR THE MISUSE OR MISINTERPRETATION OF, ANY INFORMATION CONTAINED IN THIS MANUAL. HILL PHOENIX DOES NOT WARRANT THE ACCURACY, COMPLETENESS OR TIMELINESS OF THE INFORMATION CONTAINED IN THIS MANUAL.

Copyright© 2009 Hill PHOENIX

Contents

- I. Scope of Specifications..... 1
- II. Definitions..... 1
- III. General Notice..... 2
- IV. Secondary Coolants..... 2
- V. Installation 6
 - A. General..... 6
 - B. Piping Guidelines 7
 - C. Piping Materials..... 9
 - D. Supports 12
 - E. Piping Configurations 14
 - F. Testing 18
 - G. Insulation 19
 - H. Labeling Information 24
 - I. Cleaning..... 25
- VI. System Start-Up and Operation 26
 - A. Charging Secondary Coolant 27
 - B. Pressurizing the System 28
 - C. Starting the Primary Refrigeration System 30
 - D. Balancing and Temperature Control..... 32
 - E. Adjusting Constant Differential Control..... 34
 - F. Adjusting the Warm Fluid Defrost System 35
 - H. Troubleshooting 36



Medium Temperature Secondary Coolant System Installation, Testing and Start-Up Specifications

I. SCOPE OF SPECIFICATIONS:

The specifications, contained in this manual, are provided in addition to the common documentation supplied by the customer for the complete installation of the supermarket’s refrigeration system and are intended to describe the installation, testing, and initial start-up of a Hill PHOENIX Second Nature™ Medium Temperature Secondary Coolant System only. Failure to follow these specifications will void the manufacturer’s warranty Hill PHOENIX provides.

II. DEFINITIONS:

- A. Refrigerant – A fluid used for transferring heat from one source to another.
- B. Primary Refrigerant – A fluid used to lower the temperature of a secondary coolant (i.e. R-22, R-404a, R-507, R-717).
- C. Secondary Coolant or Secondary Refrigerant – A fluid (i.e. water, glycol, brine) used to transfer heat from a heat source to a primary refrigerant.
- D. Medium-Temperature Secondary Coolant – A secondary coolant designed primarily for use above 0°F. Practical use below 0°F is limited by the fluid’s freezing point or physical properties.
- E. Freezing Point – The temperature at which one or more components of a substance (usually a liquid such as secondary coolant) begin to solidify.

For this specification, Freezing Point is used synonymously with the temperature at which solidification or crystallization begins to occur, also called Initial Crystallization Point.



Notes

F. Secondary Coolant Refrigeration System - A system where the heat from the refrigerated product, or load, is removed by means of a secondary coolant.

III. GENERAL NOTICE:

- A. The secondary coolant system (equipment, devices, piping, insulation, etc.) will be installed per the steps set forth in this "Secondary Coolant System Installation, Testing, and Start-Up Specifications" manual, the Hill PHOENIX legend and the secondary coolant piping diagram (if provided).
- B. Any changes to the installation must be submitted in writing to Hill PHOENIX for review and approval. All changes must also be confirmed by the customer. Any changes that are not approved by Hill PHOENIX will void the warranty of the system.
- C. This specification may change without notice.

IV. SECONDARY COOLANTS:

A. GENERAL

1. It is prohibited to use any secondary coolant other than those listed below without the written approval of Hill PHOENIX and the customer.
2. Medium-temperature secondary coolants must not be mixed with each other or any other liquid except with water during dilution as directed in these specifications. **NEVER MIX FLUIDS FROM DIFFERENT MANUFACTURERS.**
3. Secondary coolant systems are designed for a specific fluid based on the required application and shall not be charged with any other fluid without approval from Hill PHOENIX and the customer.
4. Before handling any secondary fluid, the contractor should be familiar with its Material Safety Data Sheet (MSDS) and its physical properties. MSDS sheets for the recommended



Notes

fluids should be obtained from the fluid manufacturer. Always check to be sure that you are working with the most current version.

5. Secondary coolants may be purchased in both concentrated (pure) and premixed (to a specific concentration) forms. However, to avoid elaborate mixing of the solution on site and to reduce the risk of contamination from impure water sources, it is strongly recommended the coolant be purchased in premixed form. When premixed coolant is selected, a small amount of concentrated fluid should be obtained and kept on site to adjust the concentration of the solution during start-up.
6. If concentrated solution is purchased, it must be diluted with water during start-up. Water used for this dilution must meet the Dilution Water Quality Requirements shown in the table below. Information on the quality of local tap water should be obtained from the local water department. If local tap water does not meet these standards, purified water must be used (i.e. distilled or reverse osmosis).

Impurity	Level
Chlorides	25 PPM, max.
Sulfates	25 PPM, max.
Calcium*	50 PPM, max.
Magnesium*	50 PPM, max.

Dilution water quality requirements

7. The concentration of diluted secondary coolant should be measured periodically during the charging and start-up process in order to ensure that the fluid is adequately mixed and that the desired freezing point is maintained. If concentrated solution is diluted on site, the concentration must be checked prior to charging the system. Fluid concentration is measured using a refractometer that is calibrated for fluids at room temperature (65-70°F). Fluid samples taken from a refrigerated system should be warmed before testing to avoid inaccurate measurements.

* Calcium and magnesium expressed as PPM calcium carbonate, total hardness as calcium carbonate must be less than 80 PPM.



Notes

Refractometers

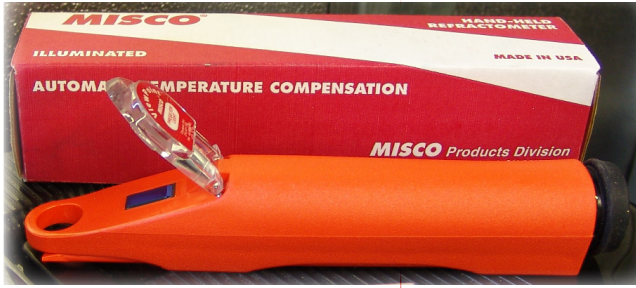

A refractometer is a device which directly indicates fluid freezing point by measuring the index of refraction of light through the fluid. Hand-held refractometers are designed for use with glycol-based fluids, though conversion graphs may be available to facilitate their use with other fluids. Refractometers may be obtained from either of these suppliers:

- Hill PHOENIX – Service Parts Department
709 Sigman Road
Conyers, GA 30013
800-518-6630
www.hillphoenix.com
- Misco Product Division,
3401 Virginia Road
Cleveland, OH 44122
216-831-1000
www.misco.com

8. Some secondary coolants are clear and colorless and therefore, are difficult to detect if a leak occurs. The addition of a colored dye aids in leak detection. FD&C Blue #1 is a food-safe dye recommended for this application. The recommended concentration of the dye is 0.005% by wt., or 100 grams (3.5 oz.) to 500 gallons of coolant. This dye may be obtained from:

- Hill PHOENIX Service Parts Dept. (see above)
- Chromatech Inc.
41208 Capital Drive
Canton, MI 48187
Phone: 734-451-1230
Dye: C75000 FD&C BLUE #1 PWD

Warning: If heat reclaim tanks are used with any secondary fluids, all sacrificial anodes and electric heaters must be removed. The material in these reacts rapidly and undesirably with many inhibitors used in coolants.



Warning: Spills of secondary coolants must be cleaned up quickly. Evaporation rates of these fluids are very slow. Proper clean-up of spilled fluids consists of dilution with clean water followed by a thorough drying of the surface. Insulation soaked with solution should be replaced as complete drying will not occur. The fluid MSDS should be consulted for proper safety measures and disposal methods.

B. MEDIUM-TEMPERATURE SECONDARY COOLANTS

1. The medium-temperature secondary coolant currently approved for use in Hill PHOENIX secondary coolant systems is *Inhibited Propylene Glycol*.

Hill PHOENIX has extensively tested inhibited propylene glycols in both systems and display cases and their performance is based on use of this fluid. Use of any secondary coolant other than that for which the system is designed is prohibited and will void the Hill PHOENIX warranty.

2. Inhibited propylene glycols are manufactured by many companies. Hill PHOENIX, however, recommends using either Dowfrost manufactured by the Dow Chemical Company, or INTERCOOL P-323 manufactured by the Interstate Chemical Company. If another brand of inhibited propylene glycol is selected, written confirmation of equivalent properties, inhibitor effects and material compatibility is required. It is *prohibited* to use uninhibited (pure) propylene glycol in any Hill PHOENIX secondary coolant system. The approved manufacturers may be contacted at:

- The Dow Chemical Company
Midland, MI 48674
800-447-4369
www.dow.com
- Interstate Chemical Company
Hermitage, PA 16148
800-422-2436
www.interstatechemical.com
- Hill PHOENIX Service Parts Dept. (see previous page)



Notes

Complete specifications and material properties are available from the Dow Chemical Company on request.

Specific gravity measured at 70°F.

Dynamic viscosity in centipoise at indicated supply temp.

- Inhibited propylene glycol is colorless, odorless and low in acute oral toxicity. The fluid is also non-flammable in solution up to 80% glycol in water. The ingredients in Dowfrost have been approved by the FDA and are listed as chemically acceptable by USDA.
- The concentration of inhibited propylene glycol solution is determined using a refractometer. For medium temperature applications, concentration shall be based on the coolant design supply temperature according to the table on the following page:

Property	DOWFROST, 35% by wt.
Color	Colorless, Transparent
Specific Gravity (at 70°F)	1.033
Boiling Point	216°F
Freezing Point	+2°F
pH	8.0-10.0

Typical properties of Dowfrost

Supply Temp.	Solution Concentration	Freezing Point	Specific Gravity	Viscosity [cP]
+15°F	40% by wt.	-6°F	1.037	22
+20°F	35% by wt.	+2°F	1.033	14
+25°F	30% by wt.	+9°F	1.029	8.1

Recommended solution concentration of Dowfrost

V. INSTALLATION:

A. GENERAL

- As with any refrigeration system, the installation of the secondary coolant system must comply with the "Safety Standard for Refrigeration Systems" (ANSI/ASHRAE Standard 15), ASME B31.5 Refrigeration Piping Standard, and the local "Uniform Building Code".
- The "Refrigeration Installation Specifications" provided by the customer defines the scope of work.



Notes

3. Contact the customer to determine if any documents are available relating to local codes or regulations.
4. Any installation specifications for the primary refrigeration system provided by the customer should in general be applied to the installation of the secondary coolant system as well.
5. All secondary coolant components must be installed according to Hill PHOENIX detailed drawings.
6. Prior to installation, the installing contractor must inspect all materials, piping, fittings, and controls of the secondary coolant system. The contractor must verify that these components are free of manufactured defects, grease, and foreign particles, and that they comply with the following temperature and pressure ratings.

For Medium Temperature (>0°F)

Temperature Range: 0 - 140°F Pressure Rating: 125 psig

The materials must satisfy the material compatibility requirements of the secondary coolant.

7. If a specific component that complies with the above pressure rating is not available, any replacement must only be installed on the suction side of the system and not on the discharge side. Such components must be protected against exposure to pressures out of the range for which they were designed. These components must also be equipped with isolating valves to disconnect them during system pressure testing.
8. All field-installed materials such as pipes, valves, fittings, gaskets or any other materials used for the secondary coolant system must be checked for material compatibility with the selected secondary coolant.



Notes

B. PIPING GUIDELINES

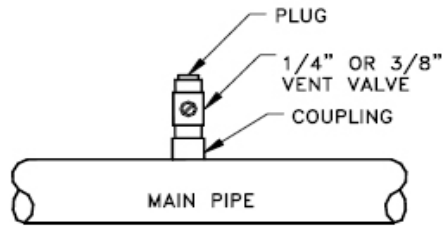

TYPICAL VENT OFF MAIN DETAIL
(AT HIGH POINT)

1. All secondary coolant pipes must be installed so as to completely eliminate air traps. All the highest points of the secondary coolant system must be equipped with 1/4" or 3/8" vent valves to remove air during

installation and maintenance. For vent valves installed in inaccessible or inconvenient locations (i.e. at the ceiling level), a 1/4" or 3/8" drop-down line may be provided for access to the valve when purging air from the piping. All vent valves must have threaded connections to connect a hose or pipe in order to remove air from the system during installation or maintenance. These valves should be capped following start-up of the system.

2. All of the lowest points of the piping must be equipped with 3/8" or 1/2" drain valves. These drain valves must have threaded connections to connect a hose or pipe in order to remove liquid from the system. These valves should be capped following start-up of the system.

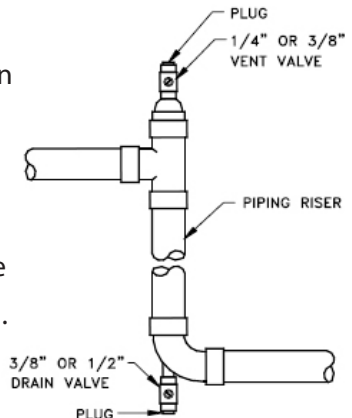

TYPICAL VENT AND DRAIN DETAIL

3. All piping must be supported in a manner that minimizes heat transfer from pipe to support (i.e. plastic or rubber spacers with unistrut clamps, or insulation with saddles on a trapeze).

4. Expansion loops must be provided for all long straight runs of pipe to allow for expansion and contraction. Common practice according to ASME B31.5 Refrigeration Piping



Standard should be followed. Horizontal expansion loops should be used to eliminate air trapping. If vertical expansion loops are required, appropriate vent and drain valves must be installed.

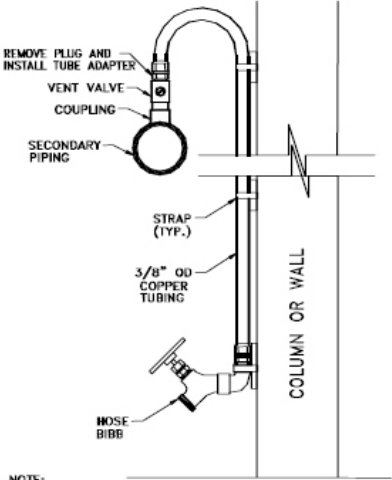

NOTE:
DROP-DOWN LINE INCLUDING HOSE BIBB BY INSTALLING CONTRACTOR.
SECONDARY VENT WITH DROP-DOWN LINE

C. PIPING MATERIALS

Many different types of materials and joining technologies are acceptable for piping secondary coolant systems. As long as these materials comply with temperature and pressure ratings, material compatibility requirements, and any local codes and regulations, can be used. Any material or technology not listed in this section must be specifically approved by both Hill PHOENIX and the customer.

1. Plastic

- a. Plastic piping is preferred and has been used successfully on medium-temperature secondary coolant installations. Many different materials have been developed for this application and new sources and methods are continuously being introduced.
- b. Any plastic piping used must be reliably proven, prior to installation, to meet all pressure, temperature and material compatibility requirements outlined in this specification. Particular attention should be paid to joining methods, as this can be the weakest point in any plastic piping system.
- c. Any plastic piping application must be reviewed and approved by the Hill PHOENIX Engineering Group and the customer before implementation.
- d. A source of plastic piping that has been engineered for use in secondary coolant systems is manufactured by:



Notes

- Georg Fischer
2882 Dow Avenue
Tustin, California 92780
800-854-4090
www.us.piping.Georgfischer.com

Georg Fischer piping can be obtained from:

- Hill PHOENIX
3601 Walnut Avenue
Chino, CA 91710
909-590-4432
www.hillphoenix.com

2. Copper

- a. Copper pipe of M, K, or L grades can be used.
- b. Copper to copper joints may be fabricated using soft solder and flux, or hard solder which is better. Many components designed for use in water systems cannot withstand the high melting temperatures associated with hard-solder and must be soft-soldered only. The component manufacturer's installation instructions should be consulted before determining which method to use.
- c. Only approved soldering materials should be used in Hill PHOENIX secondary coolant systems. Extensive research and experience has proven the suitability and reliability of these materials and their compatibility with common secondary fluids. Use of any other materials not approved by Hill PHOENIX will void the manufacturer's warranty.
- d. Soft-solder materials: The only approved soft-solder material is an alloy of silver and tin (3-5% Ag, remainder Sn) manufactured under the names Staybrite, from J.W. Harris, or Silvabrite, from Wolverine Joining Technologies. Hill PHOENIX recommends soldering using dry nitrogen.

Warning: These solders may only be used in combination with approved flux materials!

The only flux material currently approved by Hill PHOENIX is "Aqua-Brite", a glycerin-based water-soluble flux made by Canfield Technologies (see flux warning, item [g.] below).



Notes

- e. Hard-solder materials: The only hard-solder materials currently approved by Hill PHOENIX are Stay-Silv 15, made by J.W. Harris, and Silvaloy 15, made by Wolverine Joining Technologies. Hill PHOENIX recommends soldering using dry nitrogen.

Information on these materials is available at:

- J. W. Harris Co., Inc.
4501 Quality Place
Mason, OH 45040
800.733.5956
www.harrisproductsgroup.com
- Wolverine Joining Technologies
235 Kilvert St.
Warwick, RI 02886
800-225-2130
www.silvaloy.com
- Canfield Technologies, Inc.
1 Crossman Road
Sayreville, NJ 08872
732-316-2100
www.canfieldmetals.com

Warning: Only flux materials formulated from water-soluble compounds and *not containing zinc or zinc compounds* (i.e. zinc chloride) can be used for soft soldering. Petroleum-based flux materials are not acceptable as the residue formed during manufacturing is difficult to remove with standard flushing procedures. If a petroleum-based flux is accidentally used in the soft-soldering process, a special cleaning procedure will be required.

3. Steel

- a. If carbon steel pipe is used for diameters of 2" or less, the Victaulic Pressfit System with Schedule 5 externally galvanized pipe is an appropriate choice.

Warning: The Victaulic Grooved system should not be used for systems with fluid temperatures below 40°F.

Information on the Victaulic Pressfit System is available at:



Notes

- Victaulic Company of America
4901 Kesslersville Road
Easton, PA 18044
800-742-5842
www.victaulic.com

- Schedule 40 carbon steel pipe must be used with any other joining systems. The exterior surface of these pipes must be protected against corrosion.
- Before joining carbon steel pipe, the contractor must blow compressed air or nitrogen through the pipe to remove any foreign particles.
- If carbon steel piping is used, additional cleaning procedures are required before charging the system.

4. Other Materials

Flexible hoses and/or quick connect couplings can be used to connect the secondary coolant piping to case and walk-in coils. The hose material used must be

compatible with the secondary coolant and must comply with the pressure and temperature ratings of the system. The hoses must be connected to the piping, or quick connects, using hose-barb fittings and hose-clamps. Fiber-reinforced PVC material has been used successfully in medium temperature secondary coolant systems. Information on fiber-reinforced PVC is available from:

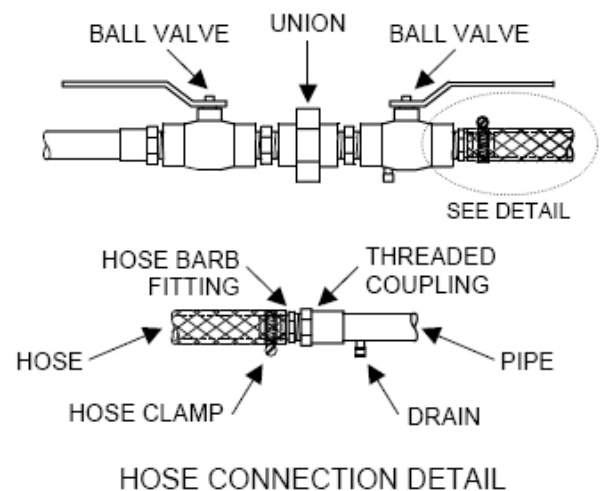

- United States Plastic Corp.
1390 Neubrecht Road
Lima, OH 45801
800-854-5498
www.usplastic.com

D. SUPPORTS

1. Copper and steel piping can be used for applications that have piping supported above ground on hangers or below ground in open or closed trenches. For above ground applications, standard pipe hanging distances should be used. Standard pipe hanging distances should be calculated to include coolant weight.
2. For plastic piping used in above ground applications, additional supports may be required to prevent pipe sagging caused by the flexibility of the pipe and the weight of the secondary coolant. The piping manufacturer's guidelines should be followed to determine proper support spacing.
3. All supports for insulated pipes should have a saddle with a smooth bearing surface that is at least three (3) pipe diameters wide, and cradles the bottom 120° of the pipe.
4. A minimum air space of one-inch (1") must be provided between lines to prevent condensation on the surface of the insulation.

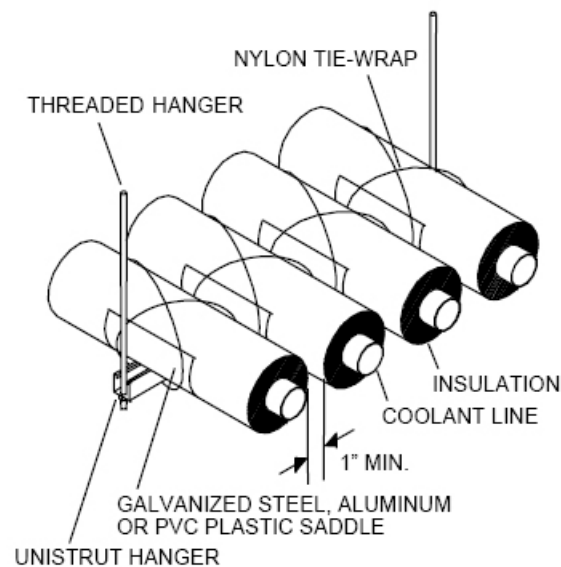

Overhead insulated piping supports



Notes

5. If underground, closed trenches (not open and accessible) are used, they must be designed in such a way that the pipe can be installed without damage to the insulation.

E. PIPING CONFIGURATIONS

Secondary fluid supply and return piping, between the refrigeration system and the refrigerated spaces, may be installed in any number of ways. The piping configuration used is generally determined during the design phase of system manufacturing, and the Hill PHOENIX recommendations and requirements must be followed to ensure proper system operation.

These configurations include:

- Individual Circuit Piping
- Loop Piping
- Modified Loop Piping

1. *Individual Circuit Piping* or multi-circuited piping consists of multiple pairs of pipes (supply and return), running to and from the system to an individual case, case line-up, or walk-in cooler. This configuration allows all refrigeration and defrost valves and controls to be located within the machine room or mechanical center, centralizing the servicing, balancing, and adjustment of the system.

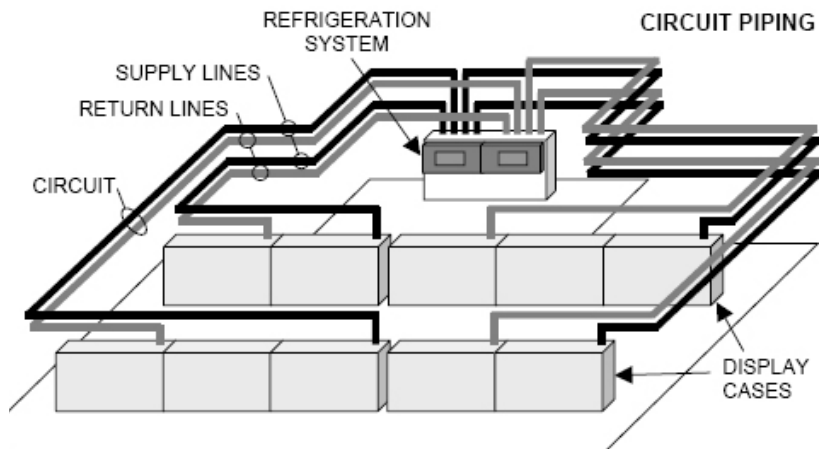

Circuited piping system

2. *Loop Piping* consists of two pipes, a supply main and a return main, often of large size, running throughout the building, passing in close proximity to each refrigerated space or fixture. Smaller branch lines are tapped off these main lines to provide supply and return fluid to individual cases, case line-ups, or walk-in coolers. In this configuration, all controls and valves for refrigeration and defrost are located in or near the refrigerated spaces. If the system uses warm fluid defrost, a third pipe for defrost supply fluid is also run from the system to the refrigerated spaces, creating what is commonly called a *three-pipe loop system*.

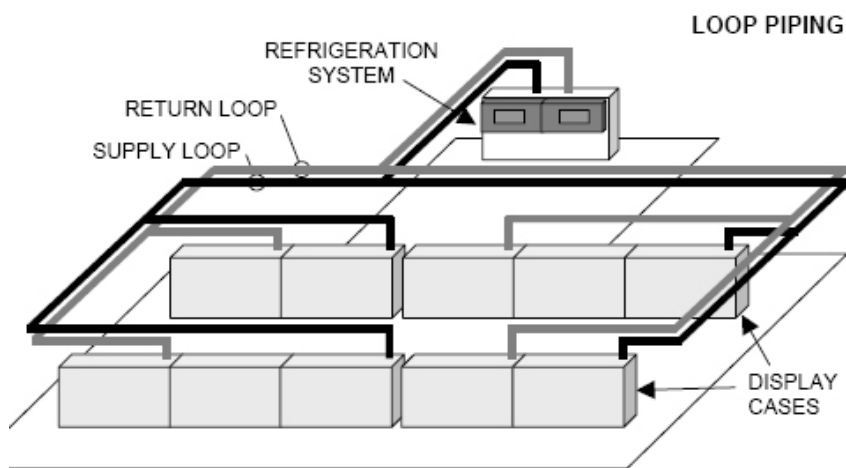

Loop piping system

3. Any combination of the above methods is referred to as a *Modified Loop Piping* system. Multiple, smaller, two- or three-pipe loops are established to supply coolant to selected areas or departments in the store which require similar fluid temperatures or defrost characteristics, and can reduce the maximum pipe sizes required to be insulated. In addition, circuits with individual supply lines may be piped with common return lines such that the majority of the control valves can be placed at the rack, while reducing piping on the return side. Remote manifolds or headers may also be utilized to centralize the location of valves and controls.



Notes

4. All circuits, regardless of piping method, should be equipped with shut-off valves on piping leading to and from the circuit to enable isolation from the main system during service.
5. Field-mounted control valves are common in secondary coolant systems. Options available for their placement include:
 - a. Solenoid and check valves may be mounted inside display cases if adequate space is available.
 - b. Valves installed outside the display case may either be field-installed or may be ordered from Hill PHOENIX as *valve assemblies*. The illustration shows typical valve assembly configurations for warm fluid and time-off defrost applications which combine solenoid valves, check valves and ball valves into single pre-piped assemblies.
 - c. Solenoid valves and check valves, if required, must be installed in the supply piping prior to the case heat exchangers, and balance valves should be installed in the return piping after the heat exchanger.
 - d. Some types of check valves (i.e. swing-type) may have restricted mounting positions. The manufacturer's mounting instructions should be followed.

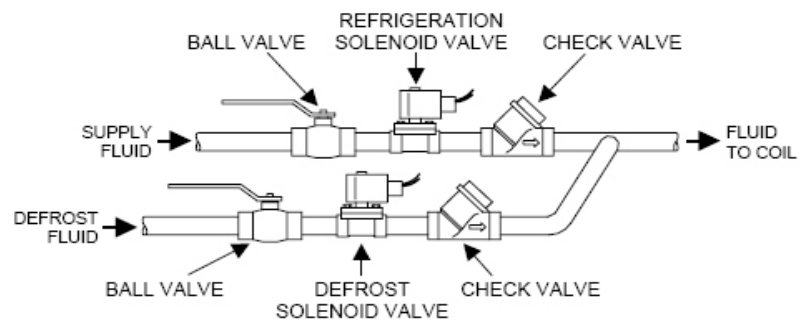

Valve Assembly for Warm Fluid Defrost

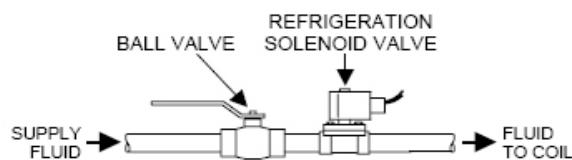

Valve Assembly for Time-Off Defrost

[Valve assemblies](#)



Notes

- e. Solenoid valves used to stop the flow of cold fluid during defrost may also be used to control temperature of the refrigerated space.
 - f. Balance valves may be used as a positive shut-off isolation valve if approved by the valve manufacturer. Balance valves used to control flow should be placed at the outlet of the controlled heat exchanger.
 - g. Placement and orientation of control valves must comply with the valve manufacturer's specifications.
6. Typical piping arrangements for a single display case or walk-in heat exchanger consist of an isolation valve in the supply line (which may be part of a valve assembly), and a balance valve in the return line. Connections for draining secondary fluid and venting air from the coil should always be installed if they have not been included from the factory. The illustration shows this piping for a common installation of a walk-in coil.

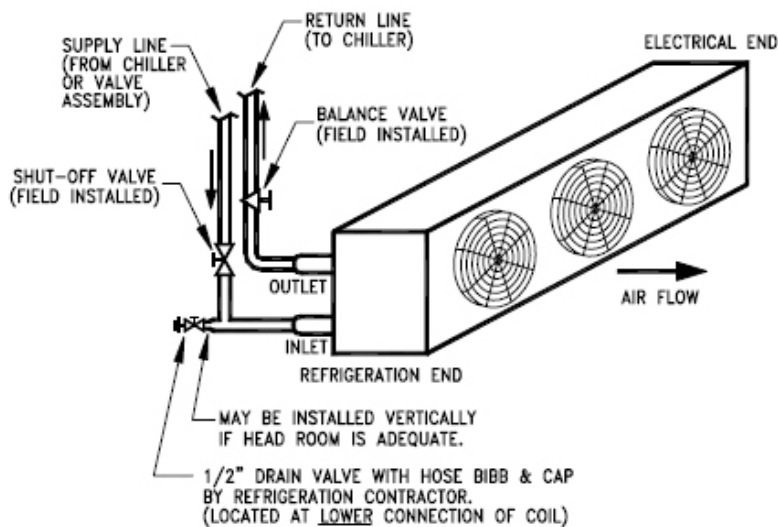

Typical walk-in coil piping

7. Circuits which contain multiple coils operating in parallel, such as a line-up of display cases or a cooler with more than one fan coil, should be piped to minimize balancing during start-up of the system. A method known as "reverse return" piping should be used and requires that the first coil connected to the



Notes

supply header be the last coil connected to the return header. This “first-in, last-out” piping helps equalize the pressure drop across each coil and simplifies the balancing procedure. The illustration shows the reverse return piping commonly installed in a three-case line-up.

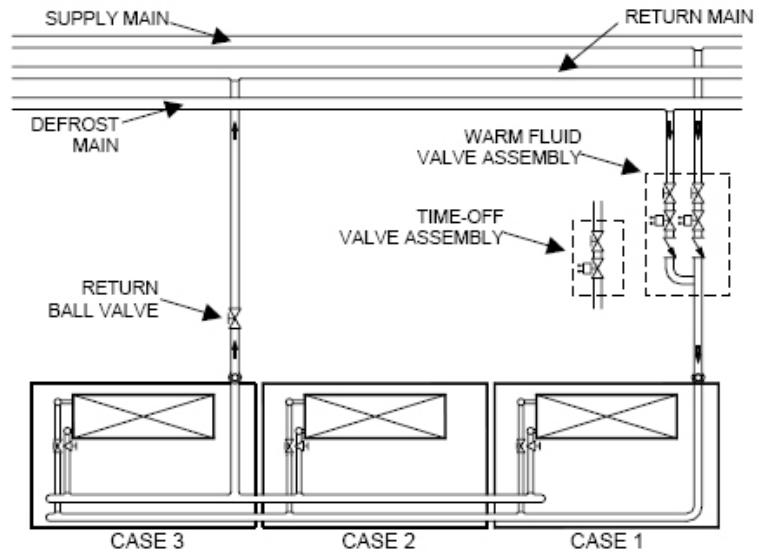

Case line-up with reverse return piping and valve stations

F. TESTING

1. Before filling the system with secondary coolant, it must be pressure tested. Pressure testing is required to eliminate leaks of secondary coolant from the system. If any elements of the system have a pressure rating less than 100 psig, they must be isolated from the system during the test procedure. However, all these elements shall be tested at the pressure rating for which they are designed. In general, the pressure testing guidelines in ASME Code for Pressure Piping, B31.5 shall be followed.
2. Either Hydraulic or Pneumatic methods can be used to leak test the secondary coolant system. The following tests can be performed:



Notes

- a. Hydraulic test by water
 - b. Pneumatic test with dry nitrogen
3. The system must be pressurized using one or another of these methods to current guidelines for pressure testing. Check with your Hill PHOENIX Field Service representative for more information. The system must hold pressure without drifting for a minimum period of four (4) hours. If any leaks are found, they must be repaired and the pressure test repeated. It is possible that during a pneumatic test, an ambient temperature decrease will cause the initial pressure to drop a small amount. However, a steady pressure must be reached before the test period begins.
 4. The pumps used in Hill PHOENIX secondary coolant systems require a wetted seal to hold pressure—dry seals will not hold air pressure. If a pneumatic test is performed, Hill PHOENIX recommends that the pump be isolated from the system to avoid damage to the mechanical seals.
 5. If plastic pipe is used, special procedures are required during testing due to the deformation and expansion of the piping under initial pressurization. Consult the pipe manufacturer's information for proper pressure and leak testing procedures.
 6. The results of the pressure test should be recorded and submitted to the customer and to the Hill PHOENIX Field Service Department.

G. INSULATION

1. General Guidelines
 - a. Insulation, in general, should be in accordance with local building codes and the customer's and insulation manufacturer's specifications.
 - b. The use of insulation materials other than those listed in this



Notes

manual requires the written approval of Hill PHOENIX and the customer.

c. The purpose of insulation on the piping system is to reduce heat transfer between the fluid lines and surrounding ambient, prevent condensation or ice formation on the pipe surfaces, and minimize corrosion of the piping materials. The following major considerations factor into the determination of insulation requirements:

- Application
- Ambient Condition (Dry Bulb Temperature, Humidity, Air Velocity)
- Insulation Material
- Desired Performance

Medium-Temperature Applications where the supply fluid temperature is +15°F to +25°F requires insulation that has been sized for one of three different ambient conditions. These are:

- Mild Conditions: Maximum severity of 80°F dry bulb temperature, 50% relative humidity, and 0 ft/min air velocity.
- Normal Conditions: Maximum severity of 85°F dry bulb temperature, 70% relative humidity, and 0 ft/min air velocity.
- Severe Conditions: Maximum severity of 90°F dry bulb temperature, 80% relative humidity, and 0 ft/min air velocity.

Although insulation thickness is also provided for the more difficult condition of “severe,” the choice of which of these to use depends on local ambient conditions and should always be evaluated for on a case-by-case basis. It is also important to realize that in some air-conditioned environments, air at or near the ceiling or roof can be higher in temperature and that evaluation of these conditions is extremely important for systems containing overhead piping.

d. The insulation sizes recommended in this manual are designed to limit heat gain into the piping network, and as a rule, are one size larger than for control of condensation only. Although insulation could be sized and installed



Notes

for the purpose of preventing condensation only, the additional heat transfer through the insulation would result in lower energy efficiency of the refrigeration system, and possible system malfunction during peak load and/or high ambient conditions. *HILL PHOENIX RECOMMENDS THE USE OF INSULATION SIZED FOR "NORMAL-CONDITIONS" FOR TYPICAL INDOOR AIR-CONDITIONED SPACE AND INSULATION SIZED FOR "SEVERE-CONDITIONS" FOR OUTDOOR APPLICATIONS.*

2. Insulation Materials

- a. The most common insulation material used for piping in commercial refrigeration systems is a flexible, closed-cell, elastomer. This type of insulation is manufactured by Armaflex and Rubatex. Technical information and more detailed installation instructions for these materials is available from them.

Information on Armaflex insulation materials:

Armacell LLC
7600 Oakwood St. Ext.
Mebane, NC 27302
919-304-3846
www.armaflex.com

Information on Rubatex insulation materials:

Rubatex Corporation
906 Adams Street
Bedford, Virginia 24523
800-782-2839
www.rubatex.com

Some applications require an insulation thickness larger than 1" which is the maximum thickness a single-layer of Closed-cell elastomer insulation. In these situations, a double layer of this material is required. Products such as Styrofoam or Trymer 2000 may be used as an alternative.

- b. Styrofoam and Trymer 2000, both produced by the Dow Chemical Company, are manufactured in rectangular bun-stock and are fabricated into sheets, pipes, and fittings.



Notes

Styrofoam is an expanded, extruded, closed-cell polystyrene foam and Trymer 2000 is a polyurethane-modified polyisocyanurate cellular foam. Both materials have a minimum insulation thickness of 1" and both should be covered with appropriate jacketing. Additional information on these materials may be obtained from:

The Dow Chemical Company
200 Larkin Center
1605 Joseph Drive
Midland, MI 48674
800-232-2436
www.dow.com/styrofoam/na/dowpipe/contact/index.htm

- c. All valves, controls and fittings in contact with refrigerated secondary coolant must be insulated in a manner which facilitates easy removal for component servicing. Components must also be insulated to minimize air pockets or voids which can, over time, collect moisture.
- d. Copper lines transporting warm fluid for defrost must be insulated with a minimum 1/2" insulation to protect against condensation. Plastic lines transporting warm fluid for defrost do not need to be insulated.
- e. To minimize insulation thickness requirements and reduce heat gain to the refrigerated piping, Hill PHOENIX strongly recommends that the contractor avoid wherever possible, running piping in nonair-conditioned spaces.
- f. Ultraviolet light will degrade most closed-cell rubber materials over time. If the insulation is to be exposed to UV light, such as an outdoor installation, the material manufacturer's guidelines for UV protection should be followed.
- g. On small sections of pipe where complex piping configurations make it unusually difficult to install a rigid type of insulation, a closed cell rubber material such as Rubatex or equivalent can be used. This material, however, should be avoided for low-temperature applications whenever possible.
- h. The tables on the next page indicate thickness for closed-cell elastomer and Styrofoam insulation for both medium-



Notes

and low-temperature applications. It is important to remember that these thickness selections are based on reduced heat transfer to the fluid and are thicker than would be required for prevention of condensation only. If ambient conditions differ from the conditions listed here, an independent evaluation of insulation thickness should be made by a qualified insulation contractor or the material manufacturer.

PIPE SIZE	MILD CONDITIONS 80°F Dry Bulb 50% RH, 0 fpm	NORMAL CONDITIONS 85°F Dry Bulb 70% RH, 0 fpm	SEVERE CONDITIONS 90°F Dry Bulb 80% RH, 0 fpm
3/4"	3/4"	1"	2"
1"	3/4"	1"	2"
1-1/4"	3/4"	1"	2"
1-1/2"	3/4"	1-1/2"	2"
2"	3/4"	1-1/2"	2"
2-1/2"	3/4"	1-1/2"	2"
3"	3/4"	1-1/2"	2"
4"	3/4"	1-1/2"	2"
5"	3/4"	1-1/2"	2"
6"	3/4"	1-1/2"	2"

Recommended thickness of Closed-cell elastomer insulation insulation for medium-temperature applications

3. Pre-Insulated Piping

- a. Pre-Insulated single and double piping systems are available for secondary coolant systems. Pre-insulated pipes consist of one or two copper or plastic pipes surrounded by insulation material (typically a polyurethane foam) and encased in a solid jacket which acts as a vapor barrier to protect against mechanical damage. Joints between pre-insulated sections of pipe are field insulated using materials supplied by the piping manufacturer and installed per the manufacturer’s instructions to maintain the same quality of insulation throughout the piping system.



Notes

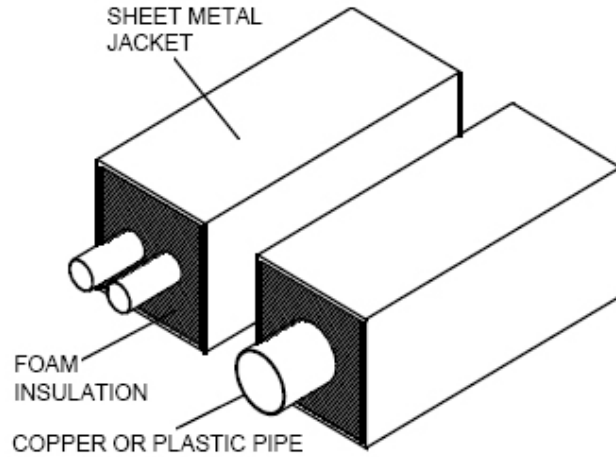

Pre-insulated piping

- b. All pre-insulated piping systems must be installed according to the piping manufacturer's specifications. The insulation thickness is selected by the piping manufacturer.
- c. Double pipe pre-insulated piping may be used to combine the supply and return pipes in a single insulated jacket so as to minimize heat loss and field-installed insulation. Double pipe pre-insulated piping should not be used for circuits with warm fluid defrost.

Additional information on pre-insulated piping systems is available from:

- Georg Fischer
2882 Dow Avenue
Tustin, California 92780
800-854-4090
www.us.piping.Georgfischer.com

H. LABELING INFORMATION

1. All secondary coolant piping, whether factory or field installed, must be properly labeled with the following information:
 - Fluid type, i.e. Secondary Coolant
 - Purpose, i.e. Supply, Return, Defrost
 - Arrows indicating direction of flow
2. In general, it is recommended that labeling comply with ANSI/



ASME Standard A13.1-81, "Scheme for the Identification of Piping Systems."

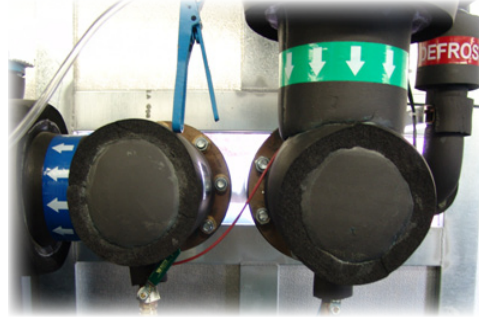

I. CLEANING

1. After testing and prior to charging with secondary coolant, the system must be flushed with clean water to remove any debris and residue from installation. During flushing, all internal valves must be opened to facilitate fluid movement through all parts of the system. Any powered control valves must be operative.
2. If carbon steel piping is used, a more thorough cleaning of the system is required to remove the oil and grease typically coating the inside of the pipes and fittings. A solution of 1-2% by volume trisodium phosphate and water must be used for flushing the system. The flushing must be continued until a clean solution is reached. The system should then be drained and rinsed with clean water before charging with secondary coolant.
3. If unusual amounts of dirt, rust or other contaminants are observed or are suspected to be in the piping system, stronger cleaners may be required. An excellent resource for additional cleaning materials for secondary systems is:

Dow HVAC System Maintenance
800-447-4369

After using any type of cleaning solution, the system should be thoroughly flushed with clean water before charging the secondary coolant.

4. After flushing, compressed air or nitrogen must be blown



Notes

- through the system to completely remove the flushing solution. All drainage valves should be completely opened to remove any flushing solution from the low points in the system.
5. After flushing, the pump strainer should be opened and cleared of debris.
 6. The system should not be left empty and/or open once flushing is completed since exposure to air and water may cause corrosion to begin. Secondary coolants contain corrosion inhibitors and should be charged as soon as possible to eliminate this danger.
 7. Special cleaning procedures for non-water-soluble flux materials should be followed if a petroleum-based flux material is used during soft-soldering of piping or components:
 - a. The system should first be filled with a mixture of hot water (up to 150°F or as hot as the system will allow) and TSP (trisodium phosphate) in a concentration of 1% by volume (1 part TSP to 100 parts water), and circulated for a minimum of four hours.
 - b. The system should then be drained and filled with a mixture of hot water (up to 120°F or as hot as the system will allow) and non-foaming detergent (such as dish soap used in automatic dishwashers) in a concentration of 0.25% by volume (1 part detergent to 400 parts water). This solution should be circulated for a minimum of four hours. *Do not use foaming detergents or detergents containing chlorides.*
 - d. The system should then be flushed with clean, hot water, repeating as many times as is necessary to eliminate the cleaning solutions.
 - e. Following flushing, the strainer should be checked for any accumulated debris. Remove the Start-Up Screen on systems that are equipped with one. Compressed nitrogen or air should be used to completely drain the water from the piping system prior to filling with secondary fluid.



VI. SYSTEM START-UP AND OPERATION:

In addition to the start-up information contained in this manual, the "Secondary Coolant Start-Up Checklist" included in the Second Nature™ Start-Up Guide should be referenced. This checklist provides a thorough list of operations which must be completed in the proper order to achieve a successful system start-up.

A. CHARGING SECONDARY COOLANT

1. The Hill PHOENIX secondary coolant system is a closed pressurized system that incorporates a pre-charged expansion tank. The expansion tank compensates for differences in the liquid volume that result from changes in the liquid temperature and provides positive pressure at the suction side of the pump which prevents cavitation.
2. Prior to charging the system, both the suction and the discharge sides of the secondary coolant pump should be equipped with pressure gauges. The pump rotation should also be visually verified. Note that centrifugal pumps operating in reverse rotation will still produce positive differential pressure and flow in the correct direction, though not at the specified design parameters.
3. If premixed coolant is used, which is strongly recommended by Hill PHOENIX, coolant should be filled directly from the drum of coolant using an external pump. If a concentrated (pure) coolant is used, it is recommended to mix and dilute the coolant prior to adding it to the system. The concentration of the mixed solution must be checked with an approved device before charging into the system. The fluid shall be charged at a point where it passes through a strainer to minimize contamination of the system.
4. Charging the system properly is important to ensure that air



Notes

is thoroughly eliminated from the system. Air trapped in the system will cause unstable operation of the pumps, make balancing the system more difficult, significantly reduce the heat transfer capacity of the heat exchangers and increase the risk of corrosion in the system.

5. Charging the piping one circuit or loop at a time achieves the best results. In order to remove the maximum amount of air during the filling process, the circuit or loop supply line should be filled first, with the circuit return valve closed and the vent on the return line open. This permits the air to gradually escape as fluid fills the supply and then the return piping.
6. All vent valves in the circuit, or loop, being charged must be open while filling with secondary coolant. Close the vent valve located at the lowest point of the circuit when liquid appears there. All vent valves must be completely closed when liquid reaches the valve located at the highest point of the circuit return. At completion of these steps, the system is nearly full of coolant but remains unpressurized (0 psig).
7. After the system has been initially filled, turn on the pump to circulate and mix the coolant. At this point, the solution concentration of the coolant should be checked again to confirm the design freezing point. The circulating liquid will also deliver any trapped air to the air removal system.

B. PRESSURIZING THE SYSTEM

1. Pressurization of the system is required to remove the remaining air from the piping and to provide positive pressure at the suction side of the pump. When the main fluid pump is running, the following conditions indicate that there is air in the system:
 - a. Unsteady coolant flow
 - b. Fluctuation of pump suction and discharge pressure



- c. Excessive noise from the pump impeller
2. Since the pressurization method involves partially or totally closing valves in the main secondary coolant lines, the primary refrigeration system should not be running during this process.
3. To pressurize the system, the fill tank must be filled with coolant. A negative pressure must be created in the suction side of the system to make the fluid flow from the tank into the system piping. This is achieved by closing Valve #1 which disconnects the air removal trap and pressurized expansion tank from the suction side of the pump. At this time, the pressure gauge on the pump suction line should read at or below 0 psig. When this is accomplished, the filling valve (Valve #2) should be slowly opened and fluid should start to flow from the fill tank into the system.

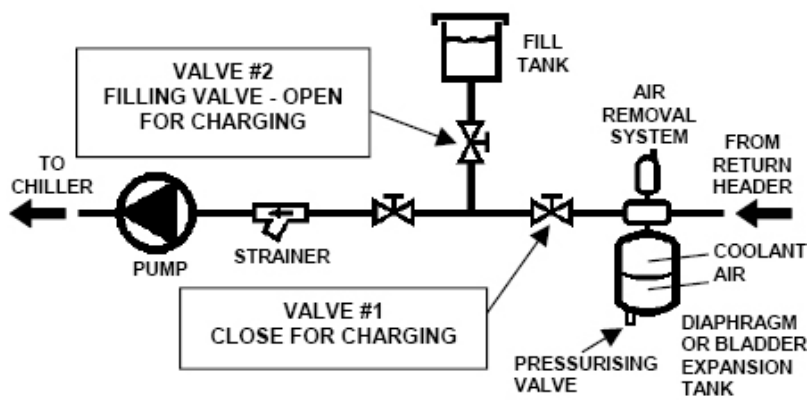

Fill tank piping arrangement

The filling valve should be closed before emptying the tank to avoid adding air to the system, then Valve #1 should be opened. This filling process should be repeated until the system no longer draws fluid from the fill tank. Additional fluid may need to be added following the start-up of the refrigeration system since the secondary coolant volume will decrease as the temperature is lowered.



Notes

4. Once the fluid is again circulating, the pump suction pressure should be above zero and the automatic air vent should be venting any remaining air from the system (air escaping from the air vent can usually be felt with a wet finger). As long as air is venting, the system should be allowed to steadily circulate fluid and continue to deliver the remaining air to the air trap. While air is venting, the pump suction pressure will continue to decrease and possibly reach atmospheric pressure.
5. The pressurizing process should be repeated until the system no longer draws fluid from the fill tank. After the system is pressurized and all air is removed, the suction pressure gauge should indicate a steady suction pressure of approximately 15 psig. This pressure is equal to the pressure of air in the expansion tank. The discharge pressure gauge reading minus the suction pressure gauge reading at this point will indicate the differential pressure of the system (the pressure loss of the fluid through all piping and components) which is equal to the pump head.
6. When the refrigeration system is started, the secondary coolant will begin to shrink in volume as the temperature is decreased. During and after this pull-down of temperature it may become necessary to add additional coolant to the system. While additional fluid is added to the system, the compressors should be temporarily turned off to eliminate the possibility of a chiller freeze-up.

C. STARTING THE PRIMARY REFRIGERATION SYSTEM

1. A chiller freeze-up occurs when there is no secondary coolant flow in the chiller while the primary refrigeration system continues to operate. This condition causes the secondary



Notes

coolant in the chiller to lower to a temperature at or below its freezing point. Flow may be lost in the chiller for a number of reasons including pump motor or impeller failure, closed discharge or suction valves and/or a blocked strainer. Since secondary coolants expand while freezing, the chiller could burst under this condition causing a catastrophic failure. For this reason, the primary refrigeration system should *never* operate when the secondary coolant pump system is not running.

2. A number of safety devices on the system protect it against chiller freeze-up. These devices must be set and their operation verified before starting the refrigeration system:
 - a. Secondary Coolant Low Temperature Thermostat
 - b. Pump Differential Pressure Switch
 - d. Compressor Suction Pressure Switch

Each of these devices is designed to turn the primary refrigeration system off when a condition occurs that could lead to a chiller freeze-up. The table below explains the function and setting of each device.

DEVICE	Low Temperature Thermostat	Differential Pressure Switch	Compressor Low Pressure Switch
FUNCTION	Turns compressor off when coolant temperature approaches freezing point.	Turns the chiller off at no or low pump differential pressure.	Turns compressor off when suction pressure approaches coolant freezing point.
SETPOINT	5-7°F above the coolant freezing point.	5 PSID	Pressure corresponding to 2-3°F above the coolant freezing point.

Safety devices for secondary coolant systems



Notes

3. There are two different pump arrangements typically used on Hill PHOENIX secondary coolant systems, one with two pumps and another with three pumps.

A two-pump arrangement consists of two identical coolant pumps, each designed to provide at least 50% of the coolant design flow.

A three-pump arrangement consists of three identical coolant pumps, each designed to provide 35% of the total coolant design flow. All of the pumps may operate together or one or two pumps may be allowed to cycle based on the measured pump head at a particular location and the strategy programmed into the system's controller.

A third option with variable speed pumping can also be used.

4. All thermal wells used for temperature probes, thermostat bulbs and expansion valve bulbs in piping at temperatures at or below 32°F, *must* be filled with thermal grease before starting the primary refrigeration system. This prevents exposed air gaps, where water may condense, freeze, expand and potentially burst the well causing secondary coolant leakage.
5. The primary refrigeration system should be started according to standard procedures normally used for conventional direct expansion systems. However, some procedures specific to secondary coolant systems are detailed below:
 - a. Typically, secondary coolant systems operate with a much lower suction return gas temperature than conventional direct expansion systems since the evaporator and compressors are located within close proximity to each other. Under these conditions, the compressor suction service valve may be iced.



- b. Several factors affect the optimum setting of the superheat in thermal expansion valves for secondary coolant chiller applications. For systems equipped without a *Superheat Sensor*, a setting of 5-7°F should be used. For systems with a superheat sensor, a setting of 7-12°F is common. The suction gas temperature for superheat calculations should be measured within 6"-12" of the suction gas exit from the chiller.
- c. When the thermal expansion valve is adjusted, Hill PHOENIX recommends that the chiller approach be checked. The chiller approach is the difference between the secondary coolant outlet temperature and the refrigerant evaporation temperature, as determined from refrigerant suction pressure. The optimum superheat setting will occur when the lowest approach is obtained without returning liquid refrigerant back to the compressors.

D. BALANCING AND TEMPERATURE CONTROL

In any installed hydronic system, balancing is required to provide adequate coolant flow to each circuit in order to maintain the required case or room temperature and insure food integrity.

Balancing is achieved through the setting of balance valves located throughout the system piping. Balance valves manufactured by Tour & Andersson are approved and recommended for use on Hill PHOENIX secondary coolant systems. Additional information on these valves may be obtained from:

The Victaulic Company of America
4901 Kesslersville Road
Easton, PA 18044
610-559-3300
www.victaulic.com

1. To initially balance the coolant flow rate properly, Hill PHOENIX recommends using a device that measures the differential pressure across the balance valve and determining the flow



Notes

rate using a hand-held device, computer program, or chart provided by the valve manufacturer. The valve should then be adjusted to match the required flow rate for the circuit which is supplied in the Hill PHOENIX refrigeration schedule.

2. If the balance valves are set before the primary system has been started, some readjustment will be required once the design fluid supply temperature has been reached. This is a result of changes in density and viscosity of the fluid as its temperature drops. These changes will also cause the coolant flow rate to be somewhat reduced.
3. Although most display cases are tested in laboratory conditions according to ASHRAE standards, several factors affect the actual amount of coolant a circuit requires. These variables include:
 - Surrounding temperature
 - Surrounding humidity
 - Surrounding air flow patterns
 - Shelf configurations
 - Product loading and temperature
 - Product turnover rate
 - Affects from adjacent cases

Because of these effects, the flow rate provided by laboratory testing only serves as a starting point. Additional adjustment may be required to compensate for these variables.

4. Circuits solenoid valves for refrigeration control may also be used for temperature control. Based on a given discharge air setpoint and a 1-2°F deadband, the solenoid valve can cycle the coolant flow on and off to provide the desired case temperature. This method of temperature control is most useful in situations where loads or store conditions change substantially from day to night. Walk-in coolers, whose doors are typically opened only during business hours, may drop



several degrees at night. In this case the solenoid can act as a safety device to prevent product freeze-up.

E. ADJUSTING CONSTANT DIFFERENTIAL CONTROL

1. Hill PHOENIX secondary coolant systems are equipped with numerous solenoid valves which open and close providing defrost to the refrigerated coils and in some situations, automatic temperature control of the refrigerated spaces. Closing these valves reduces the flow rate in the system and increases the differential pressure. To provide a constant differential pressure, and to protect the pump motor from overloading, systems are equipped with differential pressure control. The microprocessor-controller monitors the differential pressure between the supply and return headers, or the farthest circuit, and sends a signal to adjust the setting of a valve or pump(s) to correct the differential pressure. If the system is equipped with a proportional control valve or a variable speed pump, the controller will proportionally adjust the valve opening or motor speed to maintain a constant value. In a three pump system, the controller will cycle one or two pumps based on a maximum differential pressure that should not be exceeded.
2. The operating differential pressure should be determined when all balance valves have been adjusted and the system is operating at a steady condition. It is important that when this pressure is read, all refrigeration solenoid valves are open, all defrost solenoid valves are closed, any differential pressure control valve (if used) is in the fully closed position, and pumps are operating at full capacity. When these conditions are met, the differential pressure should be observed and recorded.



Notes

3. Hill PHOENIX recommends setting the value for control of the differential pressure at 5 psi above the recorded operating differential pressure.

F. ADJUSTING THE WARM FLUID DEFROST SYSTEM

1. Hill PHOENIX secondary coolant systems use either one of two different types of defrost: "time-off" and "warm-fluid". During time-off defrost, the refrigeration solenoid valve closes, stopping the flow of refrigerated liquid supplied to the coil for a preset amount of time, or can be terminated via discharge air temperature. During warm-fluid defrost, the refrigeration solenoid valve closes and the defrost solenoid valve opens to permit flow of heated secondary coolant to the coil. Warm fluid defrost is terminated by the temperature of the fluid leaving the coil and a maximum, or "fail-safe," time is used to limit the defrost length. Following termination, the defrost solenoid closes and a "drip-down" cycle permits water, from melting ice, to drain from the coil. The refrigeration solenoid valve then reopens to continue cooling. Specifications for defrost times, temperatures and termination points are supplied in the Hill PHOENIX "Secondary Coolant Display Case Application Guide."
2. Different methods of heating fluid for warm-fluid defrost are used on Hill PHOENIX secondary coolant systems. These include, but are not limited to:
 - Heat Reclaim Tanks
 - Discharge Gas Heat Exchangers
 - Defrost Pre-heaters

These methods are used individually or in combination to produce the particular defrost requirements for a given system.



H. TROUBLESHOOTING

There are two major malfunctions that secondary coolant systems are most subject to during start-up or maintenance. First, the secondary coolant supply temperature does not reach the design condition. Second, even when the design coolant supply temperature is met, the discharge air temperature in some fixtures is not reached. Possible solutions to these malfunctions, which are unique to the secondary coolant system and not caused by the primary refrigeration system, include:

1. If the design secondary coolant supply temperature is not reached:
 - a. Check the solution concentration of the secondary coolant and verify that the freezing point corresponds to the recommended values in Section IV of this guide.
 - b. Check the chiller approach temperature. A typical approach of 5-8°F should be seen.
 - c. Verify that the compressors are in the proper operational mode (loading, unloading, variable speed) and that the controller is set to maintain the required suction pressure. Verify that the compressors have the required capacity.
 - d. Check the operation of the expansion valve and verify the superheat setting. If the expansion valve exhibits large swings in superheat (hunting), check the size of the valve and orifice (if present). Also check for flashing in the liquid line in front of the expansion valve.
 - e. Verify that the defrost system is not sending warm fluid into the refrigeration supply circuits.
 - f. Measure the pressure drop on both sides of the chiller (heat exchanger). Typical design conditions for the primary refrigerant are a pressure drop of 1.0 psi. Typical pressure drop for the secondary coolant side is 5-7 psi.
2. If the design secondary coolant supply temperature is reached but refrigerated space temperatures are above design conditions:



Notes

- a. Check the store ambient conditions for unusually high temperature, humidity or any other factors which might increase the fixture loads.
 - b. Check the heat exchanger coils in the fixtures and walk-ins for the presence of air. Slowly open the vent valve on the coil header and permit any air to escape until a solid stream of liquid exits. Air inside the coil may be identified by the noise caused by the movement of bubbles and liquid. If air is trapped in a dead spot, it may be removed by temporarily increasing the coolant flow rate through the coil. This can be done by completely opening the circuit balance valve and if necessary, shutting the isolation valves on other circuits.
 - c. Check the adjustment of the balance valve and if needed, compare the flow rate with the design data.
 - d. Check the fan operation and discharge air velocity of the fixture and walk-in coils and compare with the case design data.
 - e. Check the pump head (discharge pressure minus suction pressure) and compare with pump design requirements.
3. If the secondary fluid appears cloudy or dirty, or appears to contain a large amount of suspended particles, the fluid should be filtered using a pump bypass filter housing and a cellulose core filter material designed for 20 to 25 micron particle filtration.



Notes



Second Nature Medium Temp Start-Up

Valves Open

- ✓ Isolate pumps
- ✓ Isolate Expansion Tank

Motors And Pumps

- ✓ Pump Model
- ✓ Motor HP
- ✓ Motor RPM
- ✓ Motor Amperage

Pressure Test

Water Flush

- ✓ Valves Open
- ✓ Fill With Water
- ✓ Vent System
- ✓ Pressurize With Water
- ✓ Run Pumps
 - ❖ Check Rotation
 - ❖ Check Amperage
- ✓ Cycle System Switches

Drain Water

Add Secondary Fluid

- ✓ Valves Open
- ✓ Fill With Propylene Glycol
 - ❖ Check freeze-point
- ✓ Vent System
- ✓ Pressurize With Fluid
- ✓ Run Pumps
 - ❖ Check Amperage
- ✓ Cycle System Switches

Check Freeze-point

35% Propylene Glycol = 2°F

Set Balance Valves

Set Controls

- ✓ Differential Pressure 5 psig
- ✓ Freeze-stat 10°F
- ✓ Fluid Loss Alarm <10 psig
- ✓ Critical Fluid Loss <2 psig
- ✓ Pump Strategy
- ✓ Chiller TEV Control
- ✓ Warm Fluid – Hot Gas 70°F

Start Rack

- ✓ Low Pressure Controls 8°F
- ✓ TEV Superheat
 - ❖ 100% valve 6°F
 - ❖ 60% valve 10°F

Record Settings

- ✓ Second Nature Start-Up Guide
- ✓ Send List to Hill PHOENIX

Hill PHOENIX Warranty Validation Checklist

This checklist provides space for confirming the settings, readings, and verifications you recorded in the guide. Sign and submit a copy of the completed checklist to Hill PHOENIX for validation of warranty coverage.

System Start-Up & Operation

Mail: Systems Operations 709 Sigman Rd. Conyers, GA 30013 Fax: 770.285.3085 Email: service@HillPHOENIX.com Or: your local Field Service Engineer	Contact Information Technician performing checks: Name: _____ Phone: _____ Email: _____
---	--

1. Pump skid serial number _____
2. Pump #1 Nameplate Amps _____
Actual Amps _____
3. Pump #2 Nameplate Amps _____
Actual Amps _____
4. Pump #3 Nameplate Amps _____
Actual Amps _____
5. Final fluid freeze-point of the system _____ °F
6. Balance valves confirmed set
7. Pressure relief valve on pump skid set to _____ psig
8. Expansion tank precharge pressure _____ psig
9. Differential pressure control set for _____ psid
10. Thermal grease verified in probe well
11. Enter these values:

Freeze-stat settings		
	Chiller #1	Chiller #2
Off	°F	°F
On	°F	°F
13. Fluid Loss Alarm set-point at _____ psig
14. Critical Fluid Loss Alarm set-point at _____ psig
15. Confirm pump lock-out operation
16. Verify all controller set-points match manufacturer's specs

17. List variations from manufacturer specs

18. Enter these differential pressure values:

	1 pump on	2 pumps on	3 pumps on
100% flow			
90% flow			
75% flow			
70% flow			
50% flow			

19. Enter these values:

	Chiller #1	Chiller #2
60% valve cut-in	°F	°F
60% valve cut-out	°F	°F
60% valve superheat	°F	°F
100% valve cut-in	°F	°F
100% valve cut-out	°F	°F
100% valve superheat	°F	°F

20. Hot gas line solenoid cut-in set-point _____ °F
Hot gas line solenoid cut-out set-point _____ °F
21. Final supply fluid with all cases calling for (requiring) refrigeration _____ psig
Final return fluid with all cases calling for (requiring) refrigeration _____ psig

Signature: _____ Date: _____