

Secondary Installation, Start-Up, Maintenance, and Troubleshooting

RSD-601

Hillphoenix Learning Center



Manual Use

Use of this manual is expressly limited to Hillphoenix training and other purposes as deemed appropriate by Hillphoenix. Any other uses are prohibited unless specifically approved.

This manual is for Participant's use.

Hillphoenix Learning Center

Refrigeration Systems Division Training

RSD-601

Version 3

February 1, 2017

Table of Contents

Course Overview	1
Objectives	1
Layout of the Course.....	1
Lessons.....	2
Value of the Course	2
Secondary Systems Sequence of Operation	5
Objectives	5
The Secondary Refrigeration Process	5
Primary and Secondary Refrigeration.....	6
System Components.....	11
Pump Stations.....	23
Installation Components and Materials	24
Wrap Up.....	33
Secondary Installation Practices	35
Objectives	35
Secondary Installation	35
Installation Materials.....	43
Piping Guidelines	46
End of Loop Transducer	51
Wrap Up.....	53
Secondary Start-Up Procedures.....	59
Objectives	59
Start-Up Guide.....	61
Controls Strategy.....	69
System Operation	72

Wrap Up.....	72
Hillphoenix Warranty Validation Checklist.....	75
Secondary Maintenance and Troubleshooting	77
Objectives.....	77
Maintenance Procedures.....	77
Safety and Operating Controls.....	78
Chiller Controls.....	80
Case and Walk-In Coil Checks.....	80
Visual Inspection.....	81
Preventive Maintenance.....	82
Fixture Cleaning	84
Troubleshooting Procedures.....	86
Wrap Up.....	91

Course Overview

This Hillphoenix Systems course in *Secondary Systems Installation, Start-Up, Maintenance and Troubleshooting - Version 4*, is intended to provide participants with a working knowledge of the installation, start-up, maintenance and troubleshooting procedures of Second Nature[®] secondary refrigeration systems. As participants learn about the procedures, they will start to become familiar with Secondary systems and how they operate.

Objectives

By the end of this course participants will be able to:

- List the steps in the secondary refrigeration process.
- Identify a list of major system components.
- Read and interpret specifications for installation from a refrigeration legend.
- List the materials needed for installations of secondary systems.
- Explain the piping guidelines for secondary systems.
- Describe other secondary system installation concerns.
- Describe the initial start-up procedures for a medium-temperature secondary system.
- List the steps for adding fluid to the system.
- Describe the controls strategy for the system.
- Check safety and operating controls.
- Perform visual inspections on secondary systems.
- Explain cleaning secondary fixture coils.
- List troubleshooting procedures for secondary systems.

Layout of the Course

In addition to this Overview, there are two other main sections to this and every Hillphoenix Learning Center Systems training manual: the lessons, or major topic sections, of the course dealing with each of the subject areas relating to Product Knowledge and the Conclusion which wraps up the course.

Lessons

The information covered in this course is divided into the different lessons that make up the course. The lessons are:

Lesson 1: Secondary Systems Sequence of Operation

Lesson 2: Secondary Installation Practices

Lesson 3: Secondary Start-Up Procedures

Lesson 4: Secondary Maintenance and Troubleshooting Procedures

Value of the Course

The material covered in this course is designed to provide you with the knowledge you need to intelligently discuss refrigeration needs with customers (or anyone else with an interest) and to explain the Hillphoenix answers to those needs. Whether you are a sales associate, a dealer, an associate from another division, a customer, a new Systems Associate, or new Field Service Engineer, the information in this course will aid you in working towards your company's success.

Expectations

Part of the success of this course depends on both you and the instructor meeting certain expectations.

Participants

As participants in this class, you are expected to:

- Listen
- Take part in discussions and exercises
- Ask questions
- Follow instructions
- Keep an open mind
- Apply the knowledge you obtain from this class

Instructor

The instructor of this class will:

- Teach you how to work with the secondary systems Hillphoenix products
- Answer questions
- Listen
- Guide you through exercises in which you can apply the knowledge you gain
- Keep an open mind
- Understand your level of knowledge
- Give you honest and constructive feedback

Low Temperature CO2 (LTCO2)

Lesson 1

Secondary Systems Sequence of Operation

Secondary Systems Installation, Start-Up, Maintenance and Troubleshooting is designed to provide you with an understanding of how Hillphoenix Second Nature™ Refrigeration Systems products are installed, setup, and maintained. Because Hillphoenix warrants the equipment and parts the company manufactures, it is essential its products are properly installed and maintained. It is also essential that when problems arise during operation those problems are correctly diagnosed and addressed through effective troubleshooting procedures. In this way, Hillphoenix is able to stand by its guarantees while at the same time achieving excellence.



In order to understand the installation, setup, and maintenance processes, it is best to have a basic level of familiarity with how the equipment works. Knowing the sequence of operation for a refrigeration system is a good way to understand how it works. Consequently, this lesson focuses on the information contained in the sequence of operation for Secondary systems and the components that make up those systems.

Objectives

By the end of this lesson, you will be able to:

- List the steps in the Secondary refrigeration process.
- Identify a list of major system components.

The Secondary Refrigeration Process

The Secondary refrigeration equipment that the Hillphoenix Systems Division manufactures under the Second Nature™ brand name for supermarkets and other food retailers, extends the options customers have for meeting their refrigeration needs. In addition to the conventional DX



refrigeration systems Hillphoenix produces, Second Nature™ systems provide answers to an ever growing list of customer needs that include among others, regulatory pressures and sustainability.

Because of the two major problems associated with traditional systems (potential for refrigerant leaks and plenty of refrigerant to leak) another approach to supermarket refrigeration has in recent time undergone significant development. Secondary systems use a cold intermediate fluid, or Secondary coolant, to remove heat from display cases and coolers and transfer it to an adjoining DX system through a fluid cooling evaporator, or chiller. The Secondary coolant is pumped in a closed loop between the fluid cooling evaporator and the display case. The heat is initially absorbed by the Secondary coolant through a heat exchanger inside the display case or cooler. The heat exchanger is usually a finned tube type and looks nearly identical to the evaporator used in a conventional DX display case, and for this reason, it is sometimes incorrectly referred to as an evaporator.

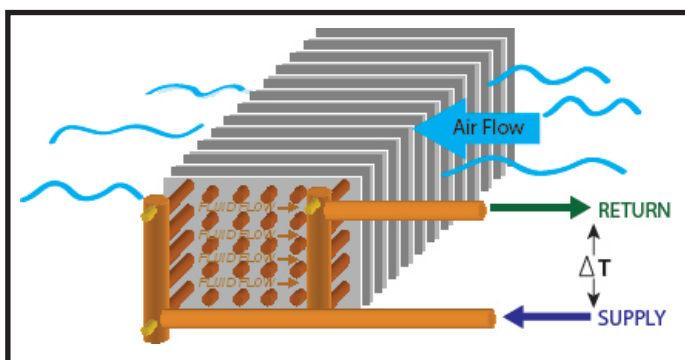

Primary and Secondary Refrigeration

Some Useful Definitions

Primary Refrigerant - A fluid used to lower the temperature of a secondary coolant (i.e., R-22, R-404a, R-507, R-410A, R-717, etc.)

Secondary Coolant (a.k.a., Secondary Refrigerant, Secondary Fluid) - A fluid used to transfer heat from a heat source (i.e. refrigerated space) to a primary refrigerant.

Single-Phase Secondary Coolant - A secondary fluid which absorbs heat by means of sensible heat transfer resulting in a change in temperature but not in state as with most primary refrigerants (i.e. propylene glycol, brine).

Two-Phase Secondary Coolant - A secondary fluid which absorbs heat by

means of latent heat transfer resulting in a change in phase (i.e., carbon dioxide, ice-slurries).

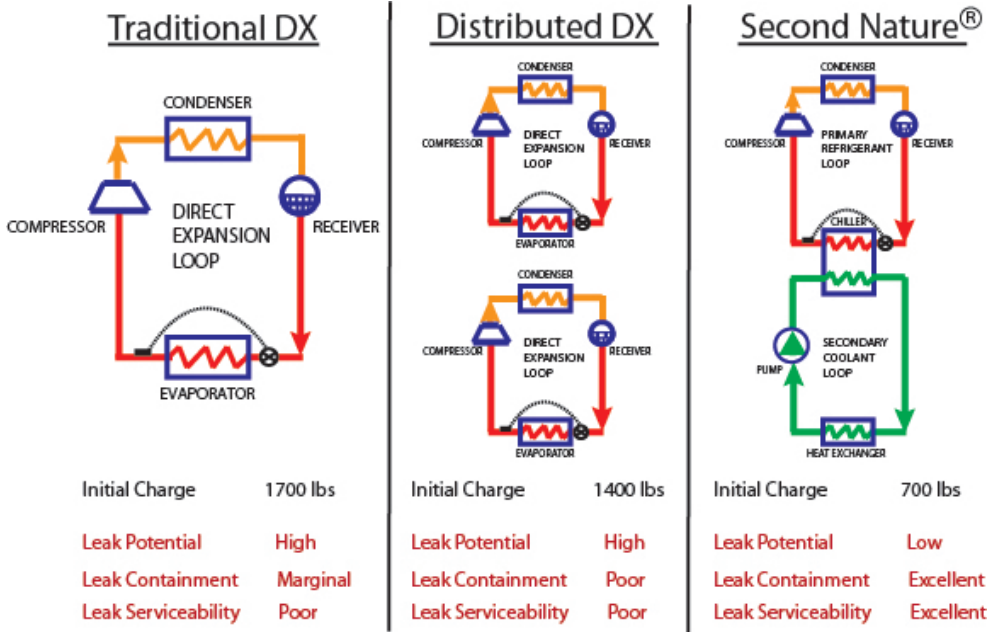

Conventional Refrigeration

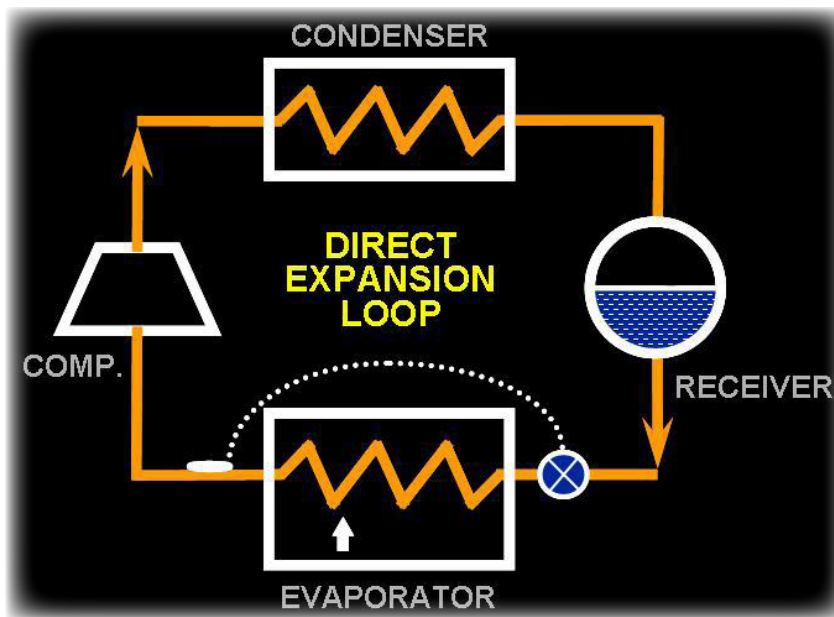

Conventional refrigeration works, in most cases, by transferring heat from one place to another through a change in the state, or phase, of a liquid. Heat can also be transferred in other ways as long as a difference in temperature (cooling) can be achieved. When a liquid (or other type of substance) is used for cooling, it absorbs heat from an object or place and then releases it to another object or place. In conventional DX systems, the liquid that is used for this purpose is a type of refrigerant. The liquid that absorbs heat from

cases and coolers in a Secondary system, however, is a type of coolant. For Hillphoenix medium-temperature Secondary applications, that coolant is a type of glycol.

In DX systems, when the refrigerant absorbs heat it changes from a liquid to a vapor. The refrigerant does this because it is absorbing latent heat. In Secondary systems, the coolant instead absorbs sensible heat. Sensible heat is so-called because the change in temperature it produces can be sensed by touch. Therefore, the only change that occurs to the coolant is a change in temperature, not in state. The coolant remains a liquid.

When the coolant reaches a plate-to-plate heat exchanger, it then releases heat to the refrigerant on the system's primary side. At this point the primary side completes the refrigeration process through the action of mechanical vapor compression, or DX refrigeration.



Mechanical Vapor Compression

The refrigerant in a conventional DX refrigeration system is subjected to a process that is called mechanical vapor compression. Through the use of mechanical devices (primarily compressors and expansion valves) that create a pressure differential between sides of the system, the refrigerant is acted upon to move heat from an area of higher concentration (an evaporator) to an area of lower concentration (a condenser).

System Comparison: DX versus Secondary Coolant

Traditional DX	Secondary Coolant
+ Proven technology - reliable	+ Significant decrease in refrigerant volumes
+ Central system - serviceable	+ Lower maintenance
+ Low equipment first cost	+ Leak potential isolated to machine room
- Long pipe runs	+ Improved temperature control means reduced product shrink
- Quantity of joints and welds	+ Hundreds have been installed over the years
+ Large volume of refrigerant	- Slight learning curve for new installers

The Secondary Side of the System

As mentioned, the primary DX side of the system works through the process of mechanical compression. In doing so, it completes the refrigeration process begun by the Secondary side. The Secondary side of the system works by absorbing sensible heat and then transferring it to the primary system. In the Secondary side of the system, liquid coolant absorbs enough sensible heat to lower the temperature of the case before giving off that heat through a heat exchanger, called a chiller, to the primary system.

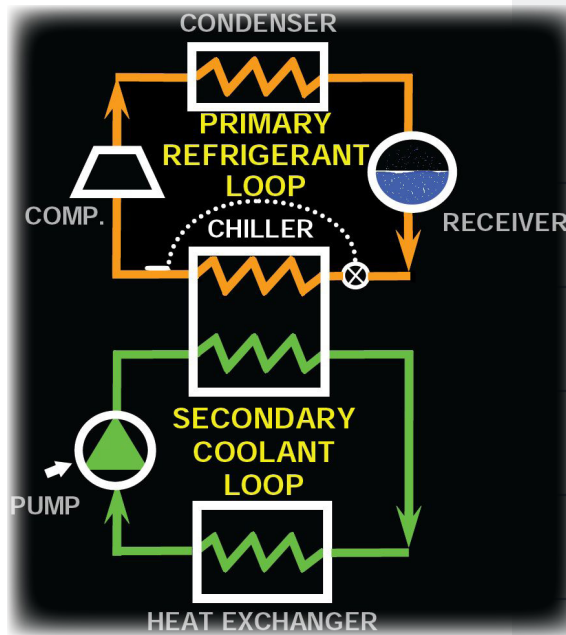

Since the Secondary system does not rely on compression to cause the coolant to flow, the way that refrigerant in the primary system does, some other means of moving the coolant through the system is necessary. Instead of a compressor, the Secondary side of the system relies on pumps. The pumps keep the coolant circulating through the system.

The Secondary coolant is pumped in a closed loop between the chiller (a fluid cooling-evaporator) and the display case. The heat is absorbed by the Secondary coolant through a heat exchanger (coil) inside the display case.



Because the chillers in a Secondary system are located in very close proximity to the rest of the vapor compression components (the primary side of the system), the total refrigerant charge is much less than in a conventional DX system. In other words, the refrigerant doesn't have to be piped all around the store.

At this point it is worth considering why managing refrigerant in the store is a concern. A number of factors have combined to make this one of the leading issues with which supermarkets must contend.

Why Is Refrigerant Management Important?

Refrigerant	Other Names	ODP Ozone Depletion Potrnital	GWP Global Warming Potential
R-22	Freon-22 (HCFC)	0.055	1800
R-404A	HP-62 (HFC)	0	3784
R-507	AZ-50 (HFC)	0	3850
R-410A	AZ-20, Puron (HFC)	0	1975
R-717	NH3, Ammonia	0	<1
R744	CO2, Carbon Dioxide	0	1

The regulatory climate in 2008:

- Stepped-up EPA enforcement of HCFCs - Continuing
- No new HCFC (R-22) equipment permitted after 2010 - Old News
- Complete HCFC (R-22) phase-out by 2020 - Old News
- Most likely increased HFC restrictions - Impact Yet to be Determined
- New refrigerants being developed by Honeywell and DuPont - Impact Yet to be Determined.

There are some indications that even these dates could change and that more aggressive timetables may be enacted.

Refrigerants and Environmental Impact

The reason for the changes in the regulatory climate is because of the effects of synthetic refrigerants upon the environment. R-22 has been recognized for some time as being harmful to the ozone layer. More recently this concern has been supplanted by worry over the global warming effects of the refrigerants replacing R-22 which, as shown in the table below, actually has a lower global warming potential than the alternatives.

In addition to regulatory compliance and environmental impact, there is another benefit to reducing the amount of refrigerant a store uses, one that directly impacts the bottom line.

In addition to regulatory compliance and environmental impact, there is another benefit to reducing the amount of refrigerant a store uses, one that directly impacts the bottom line. In estimating the initial charge refrigerant volume for a 45,000 square foot store with field piping, only around 800



pounds would be needed for a Second NatureTM systems as opposed to the 2,500 pounds needed for a comparable DX system.

A study conducted by one customer found that Second NatureTM systems use 62.5% less HFC refrigerant than conventional DX systems. That equates to an initial savings of over \$2000.

System Components

Knowing how the refrigeration process works helps in understanding where in the sequence of operation the major components of the mechanical system are and the functions they perform. In addition to the components of the primary system, secondary systems employ certain other key components.

The Secondary main components are:

- Plate-to-plate heat exchanger (chiller)
- Pumps
- Piping
- Finned tube type heat exchanger (at the case)
- Expansion tank
- Fill tank
- Air separator

- Balance valves
- Valve stations

Plate-to-Plate Heat Exchanger (Chiller)

The chiller is where heat is removed from the Secondary side of the system and given off to the primary side. Warm fluid from the coolant loop enters the chiller and, through the action of the plate-to-plate heat exchanger, gives up the heat it has absorbed from the cases and coolers.

The chiller works as the evaporator for the primary side. There is no other evaporator in the system. As with a conventional evaporator, a TXV monitors the superheat of the refrigerant. A consideration in system design is based on chiller approach. The lower

the superheat setting on the TXV, the lower the chiller approach will be. The chiller approach is the difference between the Secondary coolant outlet temperature and the saturated suction temperature (SST). For a system with R-507 that is set up to produce 20-degree coolant, the system will need to run at 13 to 15 degrees SST (50 psi).

The chiller and the entire system work through a counterflow method of heat transfer. Both the primary side's refrigerant, and the Secondary side's coolant flow through the chiller, but they enter the chiller at opposite ends and flow past each other in opposite directions.

Because the primary-side refrigerant exits the chiller at the end where the Secondary-side coolant enters, the refrigerant is said to *approach* the inlet temperature of the coolant. This counterflow causes the coolant

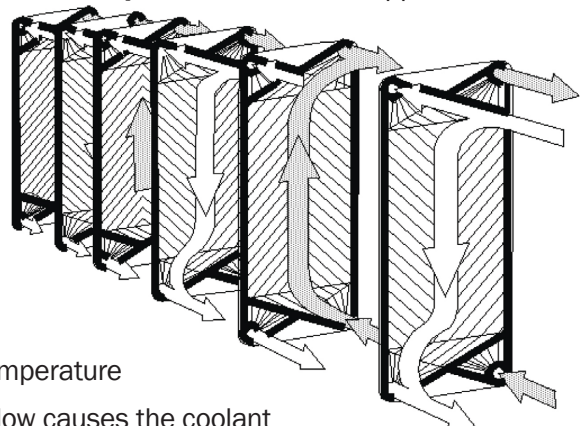

to release heat through the chiller to the refrigerant more effectively than if the two flowed in the same direction. The case and cooler heat exchangers work the same way, only there the coolant and the air flow in opposite directions across the coils.

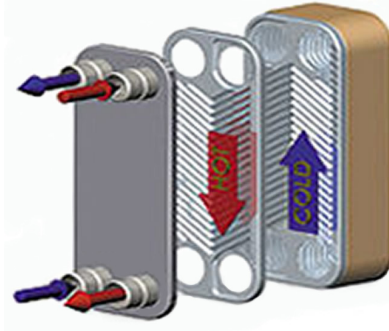

The chiller has to be sized to remove all of the case BTUs out of the fluid instead of air as in a DX system condenser.

Pumps

In a DX system, compressors create a pressure differential that causes the refrigerant to flow through the system. In the Secondary side of the system,



pumps serve a similar purpose by providing the means to circulate the coolant. The number and size of the pumps depend on the connected load of the system. In a Hillphoenix Second Nature[™] system two pumps are included so that one can provide a degree of redundancy. Second Nature[™] systems are designed to

operate both pumps under full-load conditions.

The pumps used on Second Nature[™] systems are centrifugal pumps. They use a direct-drive design with the impeller bolted directly to the

motor shaft. In the pump, water enters the suction port where the impeller slaps or throws the water toward the outer edge of the pump.

Centrifugal force drives the water toward the outlet of the pump. The impeller adds energy to the fluid which increases the velocity of the fluid sending it forward.

Secondary system pumps are usually equipped with suction strainers and isolation valves.

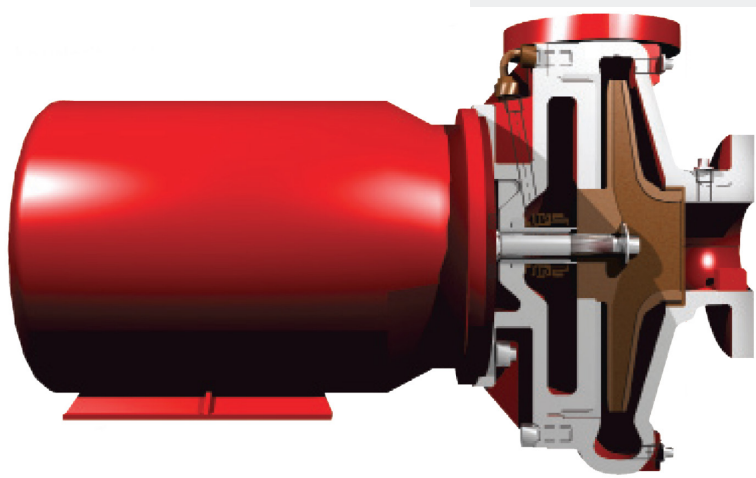

Pump Curves

As already mentioned, the size and number of pumps are determined by the design capacity of the system. A pump curve shows how the pump will perform.

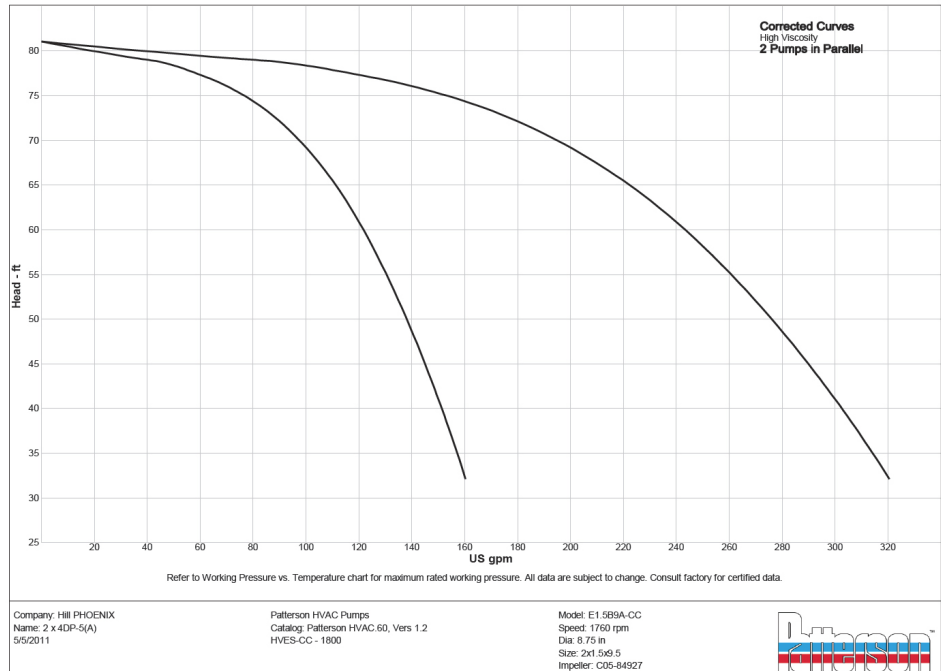

The number-of-gallons-per-minute calculation, found by adding up all of the connected loads, provides the necessary flow rate for the system.

The length of pipe, type of pipe, connected heat exchangers, and valving give the pressure drop (requirement) for the system. The combination of the flow rate and pressure drop determines the capacity of the pumps needed for the system.

The pump curve above shows two 4-pole, 5-horsepower units that run at 1760 rpm. The design capacity, as noted, is for 320 GPM with two pumps running. Other information provided includes the type of impeller used (C05-84297) and the physical dimensions of the pumps.

In fluid systems, the term “feet of head” refers to the pressure capability of the pump. If a pump can provide 100 feet of head, that means that it can raise fluid to the top of a 100’ pipe. It will not overflow a 101’ pipe. One psid (pressure differential) measured from inlet to outlet of a pump is equal to approximately two feet of head.

In addition to two-pump equipped pump stations, ones with three-pumps are also available. As typically configured, these pumps provide up to 480

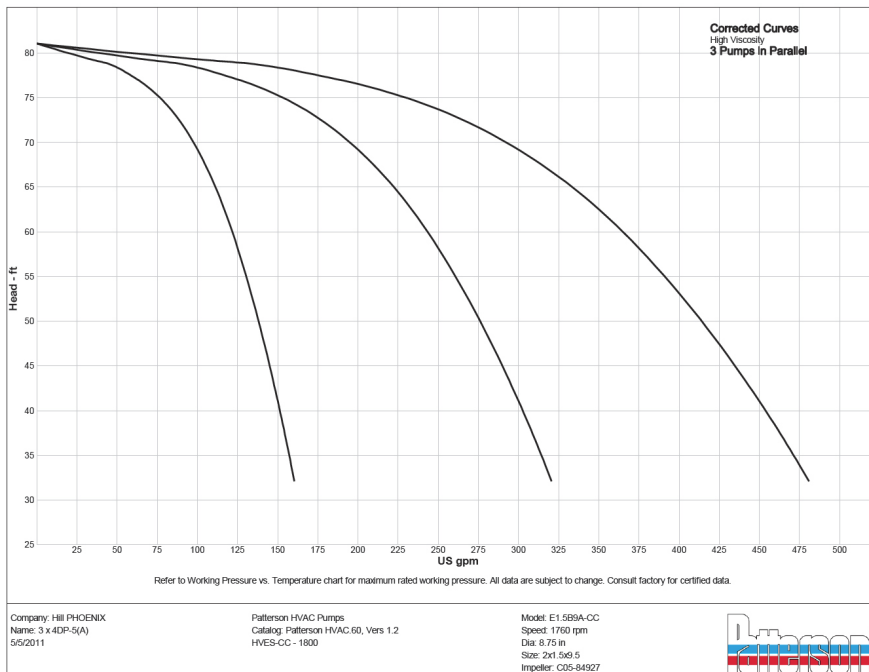

GPM with all three pumps running. As with the two-pump configuration, the three-pump version also uses 4-pole, 5-horsepower units.

Hillphoenix Second Nature™ systems are designed to run with either two or three pumps. Regardless, however, of whether two (duplex) or three (triplex) pumps are used, Second Nature™ systems are designed with some limited redundancy built in. If either pump ever has a problem, the remaining pump

on variable-speed drive-equipped (see below) pump stations can be temporarily over-driven until repairs can be made. On non-variable-speed drive-equipped pump stations the



remaining operable pump can also be run continuously until the other pump can be repaired in a timely manner.

On a triplex-pump system that some customers choose, each individual pump is designed to handle one third of the coolant design flow. All three pumps run during normal operation. Occasionally, one or two of the pumps may cycle depending on the measured pump head at a particular location in the system and the strategy programmed into the system's controller.

Triplex systems that are designed with the third pump serving as a backup or as a spare pump, must be either set up with the third pump as a lead-lag (preferred), or exercised on a daily basis for at least 10 minutes.



Variable Speed Pump Control

A control strategy that has seen increasing use is one that varies the speed of the pumps. Variable speed control works by:

- Using a differential pressure control at the end of each loop
- Controls set points are set during startup a using built-in auto tune feature
- Varying the speed of both pumps at the same frequency when running



Each pump has its own inverter. A touch screen PLC control is mounted on the front panel of the pump station. By varying the speed of the pumps, the system is able to adjust the coolant flow depending on demand and thereby saving energy whenever the refrigeration load drops. When demand rises, the control allows the pumps to increase flow until the demand is met and flow is again reduced. The amount of energy saved in comparison to conventional constant speed control in most cases is significant.

The system works off of a differential pressure control at the end of each loop. Set points automatically set using the auto turn feature on the PLC. Pump speeds are varied by frequency when running.

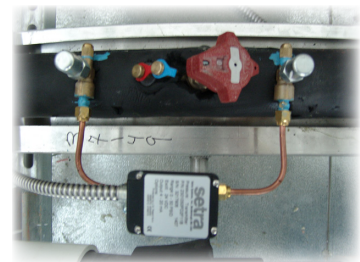

Finned-Tube Type Heat Exchanger

Although they look almost identical to conventional evaporators, *finned-tube type* heat exchangers work differently. As already pointed out the major difference between them is that there is no state change that occurs to the coolant whereas in a conventional DX evaporator the refrigerant changes from a liquid to a vapor as it absorbs heat. In the Secondary heat exchanger the liquid coolant stays a liquid. It only increases in temperature as it absorbs heat from the case or cooler, but it does not change state (sensible heat transfer).

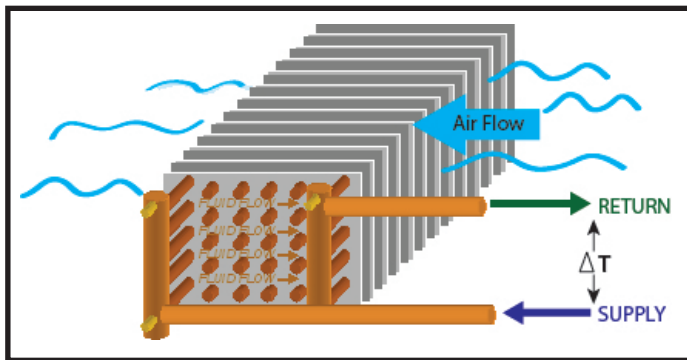
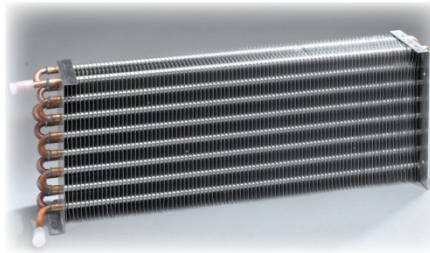

Both Secondary heat exchangers and DX evaporators are commonly referred to as coils, but Secondary coils are designed to:

- Eliminate air traps and remove air from the coil
- Drain from the bottom of the coil for service
- Handle coolant flow through their internal piping

Always carefully check to determine inlet and outlet of the coil when installing —usually the inlet is on the bottom on the air-leaving side of the coil with outlet on the top on the air-entering side. Care should be taken when installing case to case piping so as not to cross supply and return lines which unlike lines in DX systems are the same size.

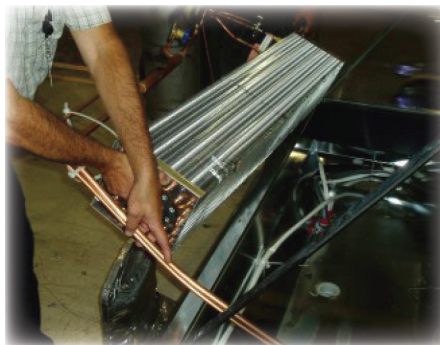

Piping

Certain key differences exist between piping for DX and Secondary systems. Foremost among these is that Secondary piping need only be water-grade. Instead of more costly Type K and L copper tubing, Secondary systems can use Type M plumber's piping or engineered plastic piping systems, both of which are less expensive than the other two types of copper.



A particular engineered plastic piping system that Hillphoenix specifically approves of for use with Second Nature™ systems is manufactured by Georg Fischer. This type of piping, according to the manufacturer, resists corrosion, reduces maintenance, lowers operating costs and speeds up installation time.



Since Secondary piping systems are designed entirely for carrying fluid, as opposed to both liquid and vapor as in DX systems, other considerations come into play when determining pipe sizing, support, and routing. Among these considerations are:

- Flow characteristics including turbulence
- Fluid weight
- Feet of head
- Slope

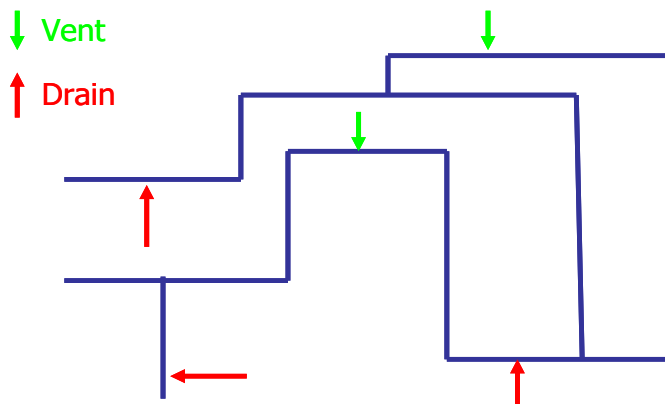

Flow characteristics to consider when installing fluid piping include turbulence that is caused by changes in direction. The turbulence that turns create increases pressure drop in the system that must be overcome by the pumps. Consequently, changes in direction should be made only as necessary.

Other considerations relating to flow characteristics have to do with the placement of vents and drains. In fluid systems, such as Secondary loop piping, air rises and fluid falls. Therefore, vents have to be placed at high points in the system and drains at low points. Both vents and drains can be anywhere they are needed in the system. For instance, any change in vertical height of a horizontal run will most likely cause a new drain or vent to be needed. Think of a line at the ceiling that drops under ductwork and then 20 feet later rises back up to the ceiling. Both of the high lines will need their own vent and the lower line will need its own drain.

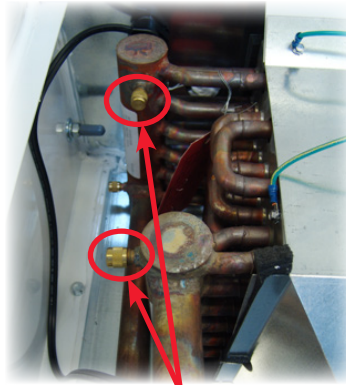

Vent Ports

Loop-Piping System

The piping method used most commonly in Secondary systems to distribute the coolant to the heat loads is called a *loop-piping system* (mentioned above). Loop piping uses from one to several large Secondary coolant supply lines from which branch piping feeds the various loads. The coolant then returns through branch piping to one or several large return lines. Defrost fluid is carried to the loads in its own separate supply loop but is usually mixed back into the system through a common return header.

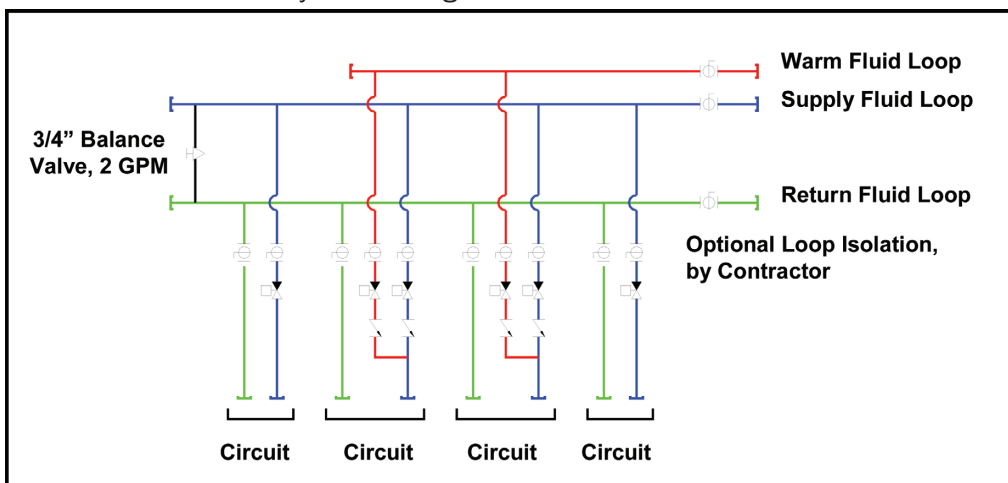

Expansion Tank

The expansion tank provides room for the coolant when conditions cause the coolant to expand. The expansion tank contains a bladder that separates air in the tank from the coolant inside in the tank. The tank is pre-charged with air on one side of the bladder to provide a starting pressure. When the system is filled, coolant is added to the point that a small amount of the coolant enters the expansion tank, thus increasing the air pressure on the other side of the bladder to equal the system pressure.

Since the system is a closed system and full of coolant, any increase in temperature of the coolant will cause an increase in the volume of the coolant. This increase in temperature can range from small, as in the slight increase in temperature that results from a warm-fluid defrost, to large, as in the case of a power failure that causes the entire system to warm up. These increases in the volume of the coolant resulting from increases in its temperature require a space in which to expand. Otherwise, the coolant's hydraulic pressure would cause a leak to occur that could break lines.



The expansion tank is the place that the expanded coolant is stored until the temperature is lowered again. At that point the air pressure in the expansion tank forces the coolant back into the system once the coolant has cooled and the pressure returns to normal due to contraction of the coolant.

It is important to pre-charge the tank with air pressure. Otherwise, the tank will fill full of coolant leaving no room for expansion when it is required. The expansion tank also assists in decreasing the effects of water hammer.



Expansion Tank

Fill Tank

After the system is filled, any further coolant added to the system is added through the *fill tank*. The fill tank is mounted on the pump station for easy

access during that process. The tank is normally isolated from the system until it is necessary to add coolant due to leaks or evaporation.

A critical provision in adding coolant to the tank is prominently noted on a large warning label on the side of the tank. As pointed out in the

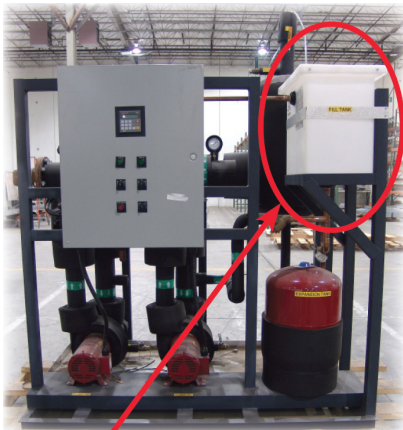

Fill Tank

Start-Up section of this course, glycol solutions should never be mixed with those from different manufacturers.

Each manufacturer uses it's own proprietary combination of inhibitors that when mixed with those of another manufacturer may have profound consequences for the safe operation of the system.

Air Separator

The *air separator* automatically removes air from the system. Air impedes the operation of the pumps. Flow in the system drops as a result of air, and the pumps become less effective. Eventually, too much air can cause the pumps to cavitate and fail. A tube at the top of the air separator vents to the fill tank.



System Valves

Balance valves are used to control the fluid flow rate. The cases are designed for a pre-determined flow rate (GPM) that satisfies their temperature requirements under design conditions. The system is balanced by adjusting these valves to the proper flow rate. This is done with the balance valve by adding restriction to the system (pressure drop). A system that is perfectly balanced will have many paths from the pump supply to the pump return, but all paths will have the same

pressure drop. The factory-recommend flow rate for each case in the system is found on the refrigeration legend.

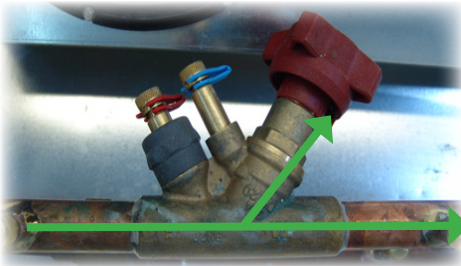

The dials on the handle are used to set the proper GPM. Once set the valve can then be locked so that it cannot be opened beyond the maximum position.

Another type of balance valve in the system is also used to set the flow rate for the proper GPM through the chiller.

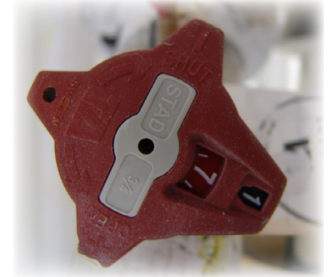

Mounted directly on the pump station is one other important kind of valve in the system. A *triple-duty* valve is connected to the discharge side of each pump. These valves act as a:

- Shut off valve
- Check valve
- Balancing valve



These valves allow the pumps to be isolated during maintenance and repair as well as used to balance the system.

One other type of valve used on the system is one that is generally referred to as a pop-off valve. The pop-off valve is a hydrostatic pressure relief valve installed on the discharge side of the pump. Non-adjustable, it is set to relieve pressure in excess of 100 psid. The valve is piped to the fill tank so that if it opens, glycol may be returned to the system.



Valve Stations

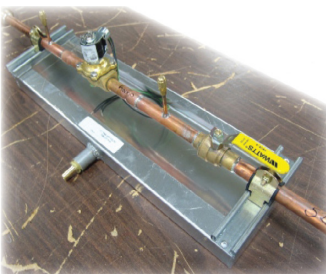

Warm fluid-defrost and solenoid valves are remotely located in valve stations. Valve stations are often placed on top of coolers. They usually include a solenoid and one or more balancing valves. Each circuit has its own valve station. They

are provided from Hillphoenix pre-piped to install at the case or cooler prior to the circuit inlet. For off-time defrost, valve stations include a



shut off valve-solenoid valve. Warm fluid valve stations have two solenoids, two check valves, two shut off valves, with one set for refrigeration and one for warm fluid defrost.

Pump Station

Although the main components of the Secondary system can be assembled in different ways, a particularly efficient way is to locate all but the heat exchanger in a single location at the case. On Hillphoenix Second Nature™ systems, that arrangement of equipment is called a *pump station*. The pump station is sometimes referred to as a pump skid.

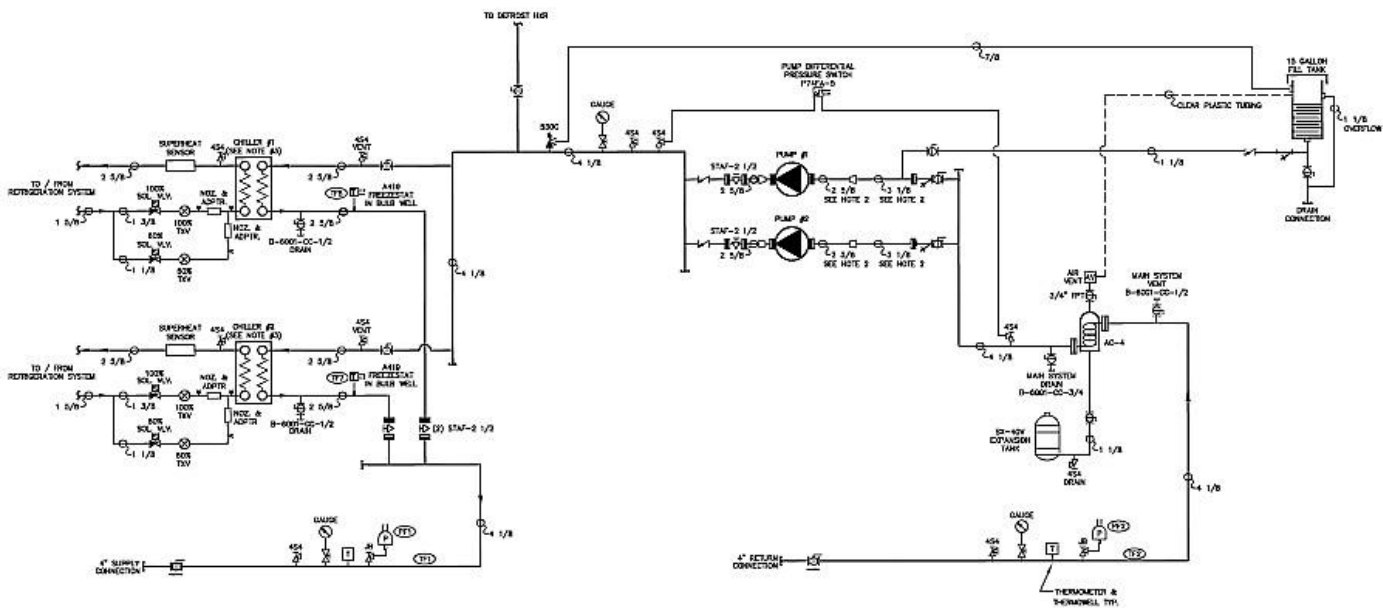
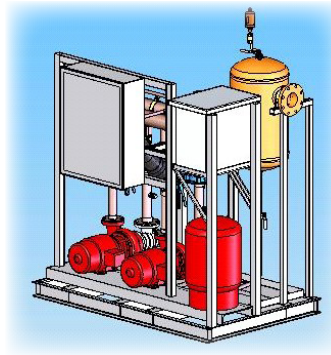

A full page spread of this diagram is included at the end of the lesson.

In much the same way that the refrigeration rack is the heart of the primary system, the pump station is heart of the Secondary system. The main components included on the pump station already discussed in this lesson are are:

- Pumps
- Chillers
- Air separator
- Fill tank
- Expansion tank

Like the refrigeration rack, the pump station contains most of the machinery for the Secondary side of the system in a single unit.



Because of the modular nature of the unit, pump stations can be designed to add Secondary refrigeration to existing DX systems.

Installation Components and Materials Standard and Optional



In addition to those described above, a number of other components and materials are need for the system to operate. These include:

- Safety devices
- Coolant
- Insulation
- Warm fluid defrost
- Smart Valve

Safety Devices

A critical condition to avoid in Secondary systems is freezing up of the chiller. A chiller freeze-up can occur when there is no Secondary coolant flow in the chiller while the primary refrigeration system continues to operate causing the Secondary coolant in the chiller to be lowered to a temperature at or below its freezing point. Flow can be lost in the chiller for a number of reasons including:

- Pump motor or impeller failure
- Closed discharge or suction valves
- A blocked strainer

Since Secondary coolants expand while freezing, the chiller could burst under this condition causing a catastrophic failure. For this reason the primary refrigeration system should never operate when the Secondary coolant system is not running.

To prevent this and other potential problems condition from occurring, certain safety devices are typically found on Secondary systems. These include:

- Low-temperature thermostats
- Pump differential pressure switches
- Compressor low-pressure switches
- Liquid line solenoid valve
- System relief valve

Each of these devices is designed to turn the primary refrigeration system off when a condition occurs that could lead to a chiller freeze-up.

Low-Temperature Thermostat (Freeze-Stat)

Any time the coolant temperature reaches a set point close to the freezing point of the coolant, the *low-temperature thermostat* turns off the chiller liquid feed solenoid valve. The set point for the low-temperature thermostat is typically in the range of from 5° to 7° higher than the coolant freezing point unless specified otherwise.

Pump Differential Pressure Switch

As already pointed out, the Secondary side of the system relies on pressure to move the coolant through the system. The pump *differential pressure switch* is an important indicator that a pump is not only running but that a differential pressure has been created.

Compressor Low-Pressure Switch

A device called a *compressor low-pressure switch* on the primary side of the system monitors the pressure in the system and shuts down the compressor in the event of a loss of pressure.

Liquid Line Solenoid Valve

The *liquid line solenoid valve* is used to isolate the chillers from the refrigeration system if required.

System Relief Valve

The *system relief valve* lessens excess pressure by allowing fluid to flow into the fill tank in the event that pressure in the system becomes excessive.

DX low-pressure controls are set so as not to allow the DX system to operate if the suction of the system is going to cause the Secondary fluid to freeze.

On the pump station itself, a number of other safety devices may be installed.

These include:

- Pump disabled alarm
- Phase monitor
- High discharge/supply pressure alarm
- Low suction/return pressure
- Pump ON/OFF switches



- Pump run light

Pump Disabled

The *pump disabled* alarm, available on some variable-speed drive-equipped pump stations, is activated immediately whenever a pump is disabled, either by turning its selector switch to the **Off** position, by turning its **motor starter protector** to the **Off** position, or during a motor overload condition. Each pump is equipped with this alarm.

Once switched, the pump will remain disabled until the alarm condition has been cleared and the alarm has been manually reset by pressing the **Station Reset** button.

Phase Monitor

Whenever phase loss, phase reversal, a voltage imbalance, or high- and low-voltage conditions occur, the *phase monitor* opens control circuit voltage, thus shutting off the pumps to save them from electrical damage.

High Discharge/Supply Pressure

The *high discharge/supply pressure* alarm, available on some variable-speed drive-equipped pump stations, activates whenever a high discharge pressure condition occurs consistently for 30 seconds.

A high discharge pressure condition occurs any time the discharge pressure rises above the high discharge pressure set point. The high discharge/supply pressure alarm protects the system from the possibility of high pressures that may damage equipment.

Low Suction/Return Pressure

The *low suction/return pressure* alarm is activated whenever a low suction pressure condition occurs. Any time the suction pressure has dropped below the low suction pressure set point, the low suction/return pressure alarm protects the system from the possibility of a large leak, high flow rates, or loss of fluid that may damage pumps.

Pump ON/OFF Switches

Each of the pumps has an *On/Off switch*. Turning the switch to *off* isolates the pump electrically so that the pump can be serviced.

The *On* position should be used for normal operation when the pump is available for service. This position will allow the pump to be used automatically in all control sequencing and operate as needed.

Pump Run Light

Each pump is equipped with a *pump run light*, located immediately above its selector switch. Each light is designated with *Pump x* inscribed on its collar to indicate to which pump it is assigned (*x* is the pump number). This light has a green lens and is used to indicate pump operation. It should be illuminated while a pump is running.

Coolant

Secondary coolant systems are designed for use with a specific fluid based on the required application and cannot be charged with any other fluid.

The coolant for which Second Nature™ systems is designed is Dowfrost manufactured by the

Dow Chemical Company.

Dowfrost is an inhibited propylene glycol solution.

Inhibited propylene glycol is colorless, odorless, and

effectively harmless to people (it is described as having “low acute oral toxicity”). Dowfrost complies with FDA and USDA regulations. If the coolant in a case were to leak, it would not present a health problem.

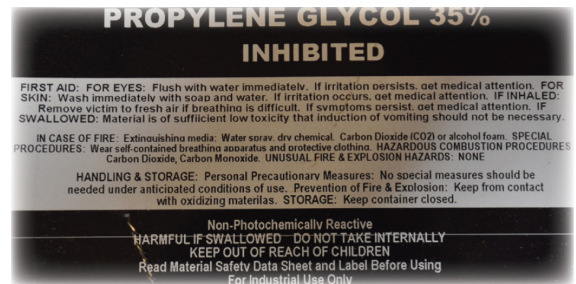

The term inhibited refers to the characteristic of the solution to not cause corrosion. Both water-grade copper and engineered plastic piping systems can be used with Dowfrost since it is not subjected to very much pressurization in the secondary system and does not cause corrosion.



Typical properties of Dowfrost include:

- Specific gravity (at 70°F) of 1.033
- Boiling point of 216°F
- Freezing point of +2°F
- pH of 8.0 to 10.0

The recommended concentration for Dowfrost coolant used in Hillphoenix Second Nature™ medium-temperature systems is 35% by weight. Use of a refractometer for determining the concentration of the coolant is essential whenever filling or adding to the system. Only distilled or reverse osmosis water should be used to dilute the coolant.

As pointed out earlier in this lesson, glycol solutions from different manufacturers must never, under any circumstances, be mixed. Each manufacturer uses different inhibitors and the consequences of combining them can be extremely harmful. A large sticker attached to the fill tank prominently warns against mixing solutions.

Dowfrost is available in both concentrated (100% pure) and premix (35%) forms. In order to avoid having to dilute concentrated solution on site and to reduce of the risk of contamination from impure water sources, it is best whenever possible to work with the premixed form. When using premixed coolant, a small amount of concentrated fluid should be obtained and kept on site to adjust the concentration of the solution during start-up.



Secondary Coolant Approved for use in Hillphoenix Secondary Systems

1. The secondary coolant approved for use in Hillphoenix secondary coolant systems is *Inhibited Propylene Glycol*.

Hillphoenix has extensively tested inhibited propylene glycols in both systems and display cases, and their performance is based on use of this fluid. Use of any secondary coolant other than that for which the system is designed is prohibited, and will void the Hillphoenix warranty.

2. Inhibited glycols are manufactured by many companies. Hillphoenix, however, recommends using either Dowfrost manufactured by the Dow Chemical Company, or INTERCOOL P-323 manufactured by the Interstate Chemical Company. If another brand of inhibited propylene glycol is selected, written confirmation of equivalent properties, inhibitor effects, and material compatibility is required. It is **prohibited** to use uninhibited (pure) propylene glycol in any Hillphoenix secondary coolant system. The approved manufacturers may be contacted at:

- The Dow Chemical Company
Midland, MI 48674
800-447-4369
www.dow.com
- Interstate Chemical Company
Hermitage, PA 16148
800-422-2436
www.interstatechemical.com

Warm Fluid Defrost

Warm Fluid (WF) can be used in Secondary systems to defrost case and cooler heat exchangers. Warm-fluid defrost has a distinct advantage over other defrost methods in that although it does put heat into the coil, due to the thermal properties of the glycol it is able to defrost the coil more effectively. This improved defrost is key to maintaining the integrity of critical temperature fresh food products that are usually kept at lower temperatures.

The warm fluid defrost system (see page 22) is fed by a branch from the discharge of the pump(s) upstream of the chillers. The WF system consists of:

- Heat exchangers to warm the fluid
- Balance (flow control) valves and solenoids
- Isolation valves

The system uses a heat exchanger in the discharge portion of the DX side to reclaim heat and warm the coolant to the desired defrost temperature. A discharge differential pressure regulating valve is situated in the discharge

line of the DX side that is actuated when defrost is initiated. This discharge regulator operates in the same manner as the discharge regulator that is used in a DX hot gas defrost, except the differential pressure used with secondary cooling is typically less. This arrangement results in less energy consumption by the secondary system during defrost. Balance valves and solenoid valves control the temperature of the defrost fluid by directing it through, or around, the discharge heat exchanger.

Insulation



Among the most common insulation materials used for refrigeration piping is a type that goes by the brand name Armaflex®. This material uses a closed-cell, elastomeric foam with very low thermal conductivity properties – in other words, it has a high insulation value.

Other types of insulation that are used include:

- Rigid cellular phenolic foam
- Cellular glass closed-cell
- Polyisocyanurate closed-cell rigid

Note that the thickness required will vary based on the type of insulation.

A number of considerations go into selecting the type of insulation to use for a particular application. These include:

- Application (coolant) temperature
- Ambient conditions such as:
 - dry-bulb temperature
 - relative humidity
 - surrounding air velocity
- Insulation material
- Desired performance

The application temperature is the temperature at which the coolant is intended to move through the piping. The ambient conditions are generally divided into three broad categories:

- Mild Conditions – maximum severity of 80°F dry bulb temperature, 50% relative humidity, and 0 ft/min air velocity
- Normal Conditions – maximum severity of 85°F dry bulb temperature, 70% relative humidity, and 0 ft/min air velocity
- Severe Conditions – maximum severity of 90°F dry bulb temperature, 80% relative humidity, and 0 ft/min air velocity

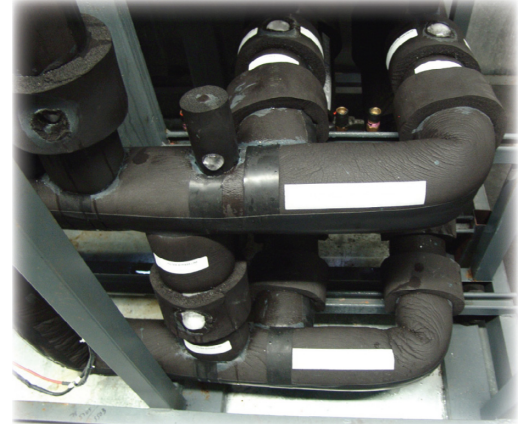

The mild design condition is typical of most indoor climate-conditioned environments in the U.S. A typical supermarket indoor design point of 75°F dry bulb temperature and 55% relative humidity can be considered equivalent to this mild condition for the purpose of sizing insulation. Although insulation thickness is usually based on the more demanding conditions of “normal” and “severe,” determining which of these to use ultimately depends on local ambient conditions and must be evaluated for each installation site. It is also important to realize that in some air-conditioned environments air at or near the ceiling or roof can be warmer (sometimes considerably so) than elsewhere in the building; consideration of these conditions is extremely important for systems containing overhead piping.

Hillphoenix recommends sizing insulation for normal conditions.

Two widely used types of insulation, polystyrene and urethane foam, have the following R-values per inch:

Polystyrene	3.5 to 5.0
Urethane	5.5 to 6.0

Wrap Up

As pointed out in the beginning of this lesson, in order to understand the installation, setup, and maintenance of Secondary refrigeration systems, it is best to have some familiarity with how the equipment works. It is also important to know what the different components at the sub-system level are that refrigeration installation contractors typically install in the field during the installation process.

By knowing this information, installers are better able to work through issues with the equipment when problems arise and thereby achieve better results installing the equipment.

Coming Up

In the next lesson the specific steps necessary to install and set up a Hillphoenix Second Nature™ system are explained. The materials and practices Hillphoenix advises installers to use are described in detail.

Lesson 1 - Secondary Systems Sequence of Operation

Hillphoenix Secondary System Piping Schematic

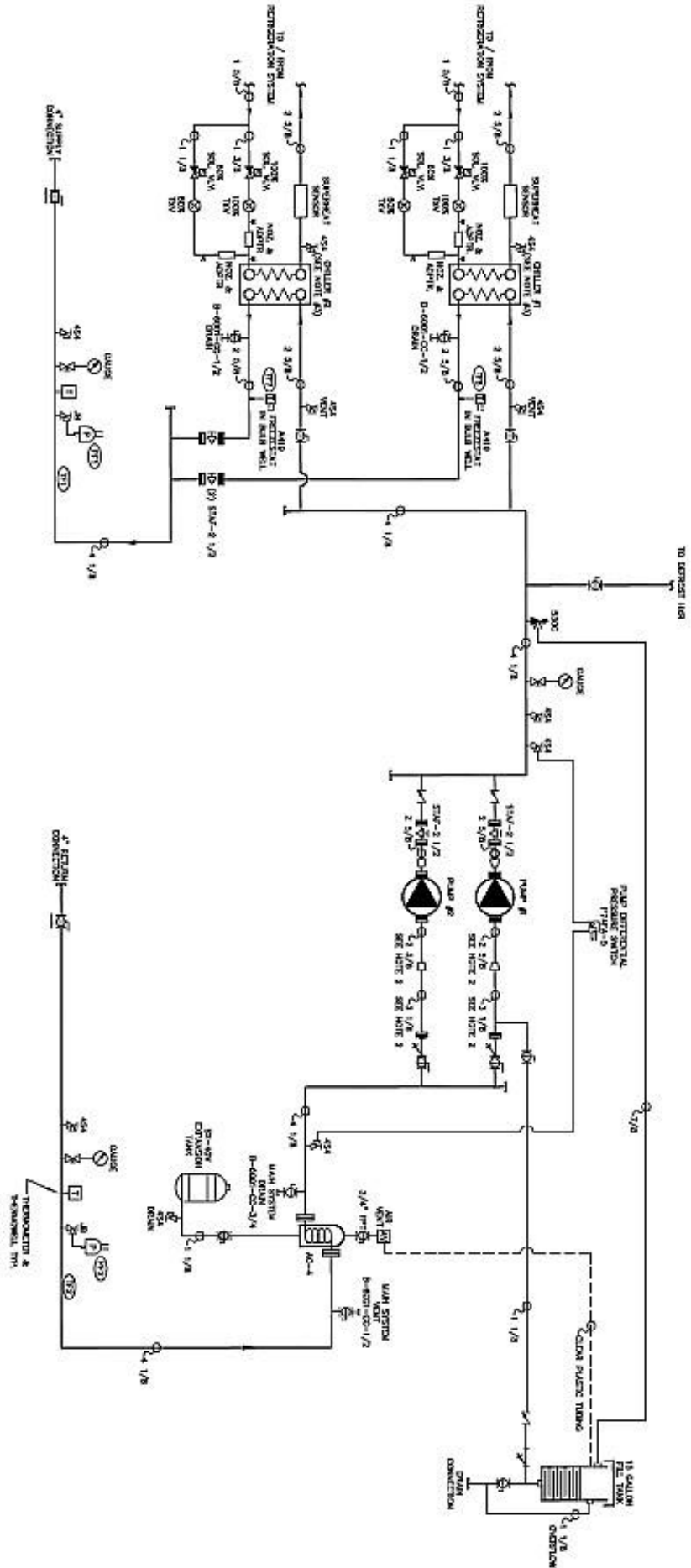

**Lesson
2**

Secondary Installation Practices

As mentioned earlier, Hillphoenix warrants all of the refrigeration systems and equipment it manufactures. In order for that warranty to have value to the customer and to ensure profitability to the company, it is essential that the systems and equipment be properly installed and started up. This lesson goes through the installation practices for Hillphoenix Second Nature™ refrigeration systems and equipment.

Objetives

By the end of this lesson, you will be able to:

- Read and interpret specifications for installation from a refrigeration legend.
- List the materials needed for installations of Secondary systems.
- Explain piping guidelines for Secondary systems.
- Describe other Secondary systems installation concerns.

Secondary Installation

Installation Specifications

The refrigeration legend, or refrigeration schedule as it is sometimes referred to, provides in a single document most of the information needed to install a system. Varying from manufacturer to manufacturer, and even from the same manufacturer, refrigeration legends come in somewhat different formats. The information contained in them, however, contains the specifications needed for installing the system. A standard part of any installation should include careful study and review of the refrigeration legend.

Among the extensive range of information contained on the legend, specifications pertaining to installation of the system include:

- Condenser requirements
- Refrigeration loads

Secondary Installation, Startup, Maintenance and Troubleshooting

Hillphoenix Learning Center

- Secondary cooling design
- Secondary coolant line sizes
- Field installed valve sizes
- Pump requirements
- Piping material and insulation requirements
- Coolant design specification

In this example of one of the types of legend provided by Hill PHOENIX look at each item to determine the requirements for the overall installation.

A full page spread of the legend is included at the end of this lesson.

Condenser Requirements

Starting at the upper left of the legend, the condenser requirements state the specification for the condensers to be installed on the system.

CONDENSER DESIGN	RACK NO.	TEMP.	TD, °F	CONDENSER MODEL NO.	CKT	CFM	CONDENSER ELECTRICAL					CONDENSER DIMENSION (L x W x H)	OPERATING WEIGHT (LBS)	
							MOTOR TYPE	VOLTS	PH	QTY	HP			EA
A	MED	15	(2)	BRH-132	56	84,800	DIRECT DRIVE	460	3	8	1 1/2	28.0	235" X 85" X 48"	3,893

Depending on the design of the system, the condensers can be any of the type commonly used for conventional refrigeration, i.e., air-cooled, water-cooled, or evaporative.

As can be seen in this example, there are two remote air-cooled condenser units for this system. Each is run by a 1½ HP, direct-drive motor. The dimensions and weight of the units are also indicated. Other information includes electrical specifications and the temperature difference for which the units are sized.

Refrigeration Loads

The capacity of the system ultimately derives from the refrigeration loads it is designed to handle. Along the left side, below the condenser requirements, the legend lists all of the cases, coolers, and other loads that the system is connected to. System numbers and a description are given for each unit. Twenty nine units, including two combos, are included in this system.

In addition to the case and cooler units, information is included for pump heat and low temperature subcooling on the system.

To the right of the description of the units is a section that contains details about the coils in the system. This information includes specifications on the quantity and capacity of the coils.

The case manufacture, Hillphoenix, is listed here, as well as the coil

manufacturer. Model numbers for the coils are provided and the required capacity in MBH (1000 BTU per Hour) is given. The total capacity for all of the coils in the loop is given at the top of the section: 946.0 MBH.

CASES / EVAPORATOR COILS										REQUIRED MBH	SYSTEM / UNIT	DESCRIPTION		
NEW / USED	NO. OF DOORS	NO. OF CASES	NO. OF COILS	CASE QUANTITY			CASE MFG.		MODEL NUMBER					
				W	L	H	ADT	PHX						
											946.0			
		24	20		(2)			ADT-208-10			(13.5)		A1	DAIRY COOLER
		25	20		(2)			WVG-340-20			(30.6)		A2	MEAT COOLER
		25	16		(2)			WK-130-12			(24.2)		A3	PRODUCE COOLER
		8		1				DHMH-E			(12.4)		A4A	MULTI-DECK FRESH CHICKEN CS
		32		1	2			DHMH-E			(49.6)		A4B	MULTI-DECK FRESH MEAT CASES
		14	6	1				Q3WB			(21.7)		A5	WIDE-ISLAND MEAT CASES
		12	12		1			PSG			(11.5)		A6	SERVICE MEAT & FISH CASES
		28		2	1			OSDM-E			(44.0)		A7	MULTI-DECK SMOKED MEAT CS
		32		1	2			OSDM-E			(50.2)		A8	MULTI-DECK SMOKED MEAT CS
								WK-100-06			(13.4)		A9A	FLORAL COOLER
		8		1				P4446B			(5.2)		A9B	OPEN FRONT FLORAL CASE
								OIPBB			(5.2)		A10A	PRODUCE ISLAND CASE
													A10B	PRODUCE ISLAND CASE
													A11	SEAFOOD COOLER
													A12	MULTI-DECK PRODUCE CASES
													A13	BAKERY CASE
													A14	ISLAND DELI CASE
													A15	SERVICE DELI CASES
													A16	MULTI-DECK SANDWICH CASE
													A17	MULTI-DECK PRODUCE CASES
													A18	MULTI-DECK PRODUCE CASES
													A19	MULTI-DECK DAIRY CASES
													A20A	MULTI-DECK DAIRY CASES
													A20B	MULTI-DECK DAIRY CASES
													A21	MULTI-DECK DAIRY CASES
													A22	MULTI-DECK DAIRY CASES
													A23	MULTI-DECK BEVERAGE CASES
													A24	MULTI-DECK BEVERAGE CASES
													A25	OPEN MEAT PREP
													A26	SEAFOOD PREP
													A27	BAKERY COOLER
													A28	PRODUCE PREP
													A29	BACK BAR
													PH	PUMP HEAT
													LTSC	LOW TEMP. SUBCOOLER
													A	HILL-PHOENIX PARALLEL SYSTEM

Refrigeration Loads

Secondary Cooling Design

The next section to the right lists the flow rate in GPM (Gallons Per Minute) for the piping branches connected to the refrigeration loads. Along with the individual branches, the flow rate for the entire system is given: 284.1 GPM.

The type of defrost for each is also shown in this section. This system uses Warm Fluid (WF) and Time Off (TO) defrost methods.

One other item in this section that is of critical importance is the specification for the design coolant shown at the bottom. As can be seen, the system is designed to use a 35% by weight (WT) Dowfrost propylene glycol solution.

9.3		IU
7.0		TO
12.9		TO
4.8		TO
2.5		TO
3.6		TO
3.7		WF
		N/A
		N/A
	GLYCOL 20	
	(35% WT PROPYLENE GLYCOL)	
	(DOWFROST)	

SECONDARY COOLING DESIGN						
DISCHARGE, °F X ROOM TEMP, °F	SECONDARY COOLANT TYPE	REFRIGERATION			DEFROST	
		SUPPLY TEMP, °F	BRANCH	GROUPING OF FLOWS	DEFROST TYPE**	FLUID TEMP, °F
			GALLONS/MIN.			
			GALLONS/MIN.			GALLONS/MIN.
				284.1		10.0
			15.4		TO	
			15.0		WF	
			7.6		TO	
			7.6		TO	
			30.4		TO	
			15.9		WF	
			9.2		WF	
			13.7		TO	
			15.7		TO	
			2.5		TO	
			2.6		TO	
			2.6		TO	
			5.3		WF	
			5.8		TO	
			15.0		TO	

JP PIPING DIAGRAMS
R4.2

Secondary Coolant Line Size

The correct line size for refrigeration of piping is of critical importance for any system. This section shows the branch and main line sizes. The line sizes for the system's warm-fluid defrost (WF) are also shown in this section.

Another note, in this section, again refers to the piping diagrams. In this case the reference is to the Lineal Feet of piping.

An additional notation, in the column heading, refers to the Notes section on the legend located in the upper right corner. The note there for this entry explains that lineal footage shown is approximate and that it is up to the contractor to verify actual line runs.

Another section of information related to line size is also contained at the top of the legend. The Line Size Guide for Secondary Cooling includes flow rates for the different pipe sizes. At the bottom of this section is a note to "consult Engineering if there is any question." HillPhoenix Engineering is available to assist the contractor with questions about the

SECONDARY COOLANT LINE SIZE						
ROUTE*	BRANCH			MAIN		
	LINEAL FEET - 1 WAY TO 1ST CASE/COIL (SEE NOTE 1)	SUPPLY & RETURN	DEFROST (WF)	LINEAL FEET - 1 WAY (SEE NOTE 1)	SUPPLY & RETURN	DEFROST (WF)
					4	1 2
		1 4				
		1 4				
		1				
		1				
		2				
		1 2	1 4			

installation of the company's systems.

SECONDARY COOLING CIRCUIT DESIGNATION		APPROX. LINE SIZE GUIDE FOR SECONDARY COOLING		NOTES: 1. TOTAL LINEAL FOOTAGE AS SHOWN IS APPROXIMATE AND IS USED FOR LINE SIZING ONLY. INSTALLING CONTRACTOR SHOULD VERIFY WITH LAYOUT FOR ACTUAL LINE RUN. 2. REFER TO INSTALLATION SPECIFICATIONS FOR MORE INFORMATION. 3. REFER TO EQUIPMENT MANUALS FOR INSTALLATION, TESTING AND START-UP.
PIPE SIZE		GPM		
3/4"		0-2		RECOMMENDED LOW VOLTAGE WIRES FOR CPC-RMCC SYSTEM 1. INPUTS AND OUTPUTS TEMPERATURE PROBES (AI): 22 GA, 2 CONDUCTORS, SHIELDED, BELDEN #8761 OR EQUAL. PRESSURE TRANSDUCERS (AI): 22 GA, 3 CONDUCTORS, SHIELDED, BELDEN #8771 OR EQUAL. LEAK DETECTORS (AI): 22 GA, 4 CONDUCTORS, SHIELDED, BELDEN #8729 OR EQUAL. DIGITAL INPUT (DI): 22 GA, 2 CONDUCTORS, SHIELDED, BELDEN #8761 OR EQUAL. MIXING VALVE (AO): 18 GA, 4 CONDUCTORS, SHIELDED, BELDEN #9418 OR EQUAL. 2. RS485 NETWORK 22 GA, 3 CONDUCTORS, SHIELDED, BELDEN #8771 OR EQUAL.
1"		2.5-7		
1 1/4"		7.5-15		
1 1/2"		16-25		
2"		26-45		
2 1/2"		46-75		
3"		76-140		NOTE: CONSULT ENGINEERING IF THERE IS ANY QUESTION ON LINE SIZING.
4"		141-250		

ELECTRICAL REQUIREMENTS										CONTROL WIRES		REMARKS
PS OHZ	CASE / COIL HEATERS 208 VOLTS +-			COIL FAN -1 PH++		CONDENSING UNIT		CHILLER		CONTROL Wires		
	L1	L2	L3	AMPERAGE, A	VOLTAGE, V	COMP'R & BODY CLO FAN, RLA 460 V	DEFROST/ CONTROL FLA 208 V	TOTAL AMPS PHASES (1-3P CONNECTION)	COOLANT PUMP, 460 V	CONTROL PANEL	RACK CONTROLLER INFO. SEE BELOW	SYSTEM/UNIT NO.
				14.4	120							1
				21.0	120							A1
				8.4	120							A2
												A3
												A4A
				3.73								

Piping Plan

Another document that is usually included with the legend is a Piping Plan.

On the Piping Plan, the piping runs are shown on a layout of the store. When

planning an installation

it is a good idea to study

the legend along with the

Piping Plan. The Piping

Plan for this legend is

shown here.

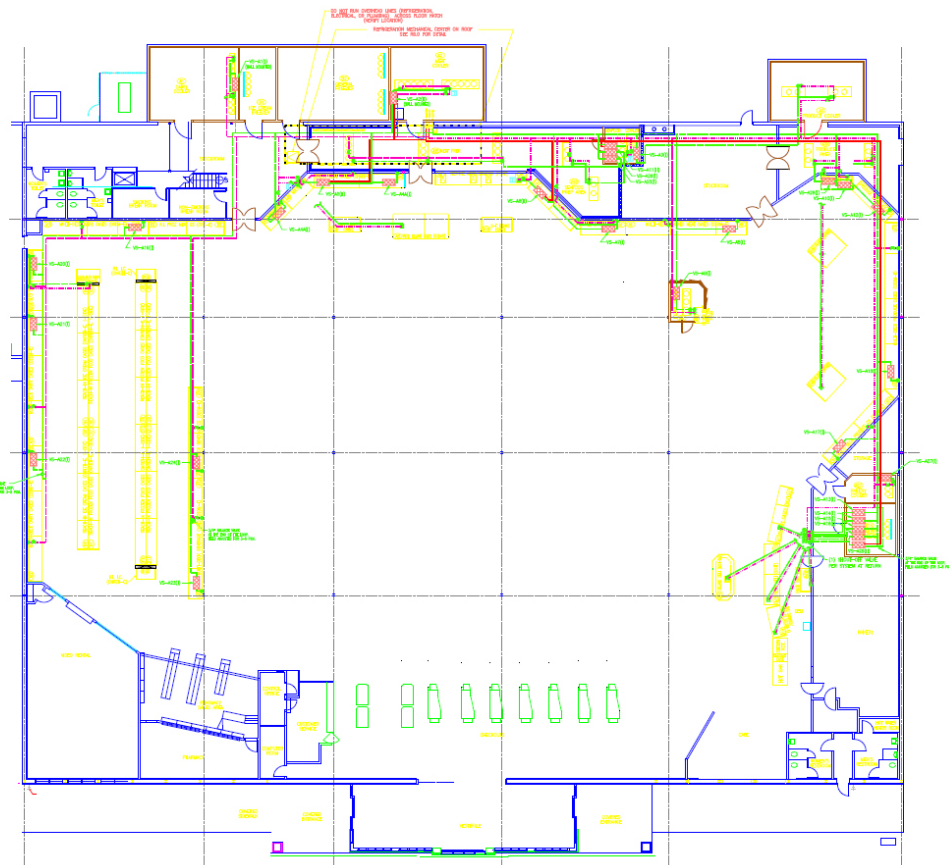

A full page spread of the piping plan is included at the end of this lesson.

Field Installed Valve Sizes

The next section of interest contains information about the valves and valve stations that the contractor will need to install. These specifically include valves to be installed in valve stations for defrost and Shut-Off valves for the Main Return line.

A notation for each valve station indicates the type of defrost for which the valve station is equipped. The sizes for the Shut-Off valves are given in that column. Another notation (MC), at the top each column, indicates that these valves are furnished by the manufacturer and to be installed by the contractor.

FIELD INSTALLED VALVE SIZES - SEE INST. CODE +							
MC	M	MC	MC	MC	MC	MC	MC
VALVE STATION TYPE I - TIME-OFF II - WARM FLUID (3 PIPE) III - WARM FLUID (4 PIPE) SOLENOID VALVE(S) AT CASE - 208 V	SUPPLY SHUT-OFF VALVE (@ FIXTURE)	RETURN BALANCE VALVE (@ MAIN OR FIXTURE)	RETURN SHUT-OFF VALVE (@ MAIN OR FIXTURE)	MAIN RETURN BALANCE VALVE (CB-S)	MAIN RETURN SHUT-OFF VALVE		
I							1 4
II							1 4
I							1
I							1
I							2

Valve Sizes

In the upper right of the legend, immediately below showing the Secondary Cooling Circuit Designations, are the Valve Station Designations. Notice that the defrost types shown are the same as those in the Field Installed Valve Sizes section.

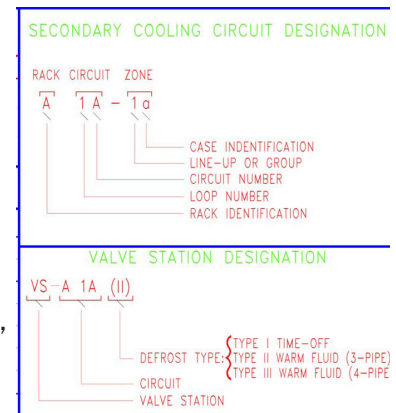

Circuit and Valve Station Designations

In the Secondary Circuit Designations section, designations for the Zone, Circuit, and (Refrigeration) Rack are shown. Of course, the only rack designation for this Secondary system is the rack A to which it is connected.

Flow Rate Calculation

The formula for calculating flow rate per case or evaporator where all coils are the same size is:

$$\text{Gallons per Minute (GPM)} = \text{Circuit GPM} / \text{Number of Coils}$$

The flow rate calculation for Circuit A2 evaporators (multiple heat exchangers

of the same size) is based on the following factors:

- Evaporators (heat exchangers) or case coils of the same size
 $GPM = 15gpm$
- Number of Evaporators (heat exchangers) on Circuit A2 = 2
 (WKG-340)
- $GPM/Evaporators = \text{flow rate per Evaporator}$
 $15/2=7.5GPM$

The formula for calculating flow rate per case or evaporator where all coils are not the same size is:

- Gallons per Minute (GPM) = (Circuit GPM / total circuit length in ft) X case length in ft
- Example Circuit A23 (see page 56) has (2) 8 ft cases and (1) 12 ft case
- Circuit GPM = 9.3
- Total circuit length = 32 ft (2 X 12 + 8)
- For 12 ft cases: $9.3 (GPM) / 32 (ft) = 0.29 \times 12 = 3.5 GPM$
- For 8 ft case: $9.3 (GPM) / 32 (ft) = 0.29 \times 8 = 2.32 GPM$

Once the flow rate is calculated, the settings for the balance valves can then be determined by using a Valve Setting Wheel.

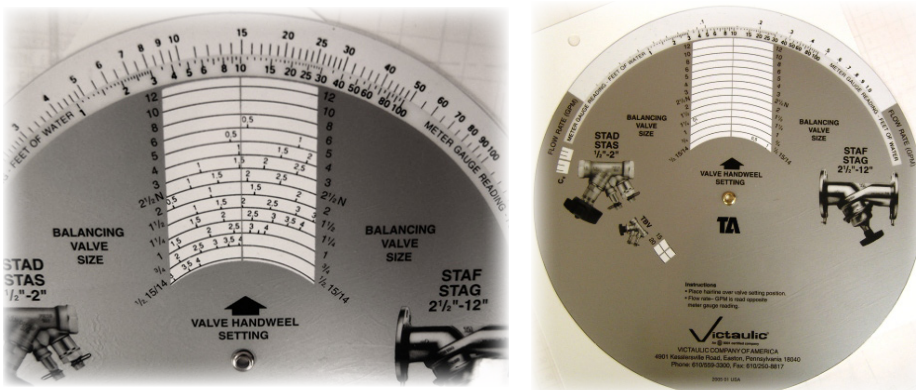

Pump Requirements

Information for the Chiller Pumps is shown at the top center of the legend. Unit (designation), flow rate (GPM), horsepower and number of units, and remarks are indicated. For this system the information describes a two-

pump unit that provides 284.1 GPM. Both 7½ HP pumps, as noted in the remarks, run during operation.

CHILLER PUMP				
UNIT	GPM	HEAD	HP	REMARKS
A	284.1		(2) 7½	BOTH RUNNING

Pump Requirements

Piping Material and Insulation Requirements

Located directly under the Chiller Pump information, are specifications for piping material and insulation requirements. Piping material specifications are often provided by the customer as is the case in this legend.

Specifications for insulation materials follow the industry guidelines with values for Low and Medium-Temperature piping. This system, of course, is a medium-temperature system so only those values will apply.

Coolant Design Specification

A final key item of information for the installation of the system, it the Coolant Design specification. Included at the center bottom of the legend, this critical information specifies the only coolant with which the system is

SECONDARY COOLANT PIPE COPPER TUBING: TYPE L				NOTE: DO NOT USE GALVANIZED PIPE AND FITTINGS.
INSULATION FOR COOLANT PIPE (SUPPLY & RETURN)				
PIPE SIZE	TYPE	LOW TEMP (-20°F) NON A/C SPACE		MED TEMP (20°F) NON A/C SPACE
		STYROFOAM W/JACKET	TRYMER 2000 W/JACKET	ARMAFLEX OR RUBATEX
1/2" - 1 1/2"		2 1/2"	1 1/2"	1"
2" - 2 1/2"		2 1/2"	1 1/2"	1 1/2"
3"		3"	2"	1 1/2"
4"		-	2-1/2"	1 1/2"
6"		-	-	2"

NOTE: ALL WARM FLUID DEFROST LINES REQUIRE 1/2" ARMAFLEX OR RUBATEX TYPE INSULATION. * WITH JACKETS

Pipe & Insulation Requirements

designed to operate; in this case Dowfrost, 35 percent by weight, propylene glycol. The design temperature for the coolant is given as 20 degrees.

Considerably more information than these items is included in the legend. The refrigeration Lines sizes, for instance, are given for the branch and main lines.

GLYCOL	20	
(35% WT PROPYLENE GLYCOL)	(DOWFROST)	

Glycol Specification

Loop balance valve settings, for instance, are also given at the bottom of page. These valves help to keep the system at a constant temperature by providing a path of flow from the supply header to the return header. This path of flow also keeps the pumps from deadheading and assists in preventing water hammer.

(2) 3/4 BALANCE VALVES AT FARTHEST END OF LOOP, FIELD ADJUSTED TO 5-7 GPM EACH.

Loop Balance Valve Settings

Other information on the legend includes electrical and controller specifications as well as environmental design conditions. Information for condensing the system's units is also included.

Installation Materials

The installation materials for Secondary refrigeration systems include:

- Piping
- Insulation and Piping Supports
- Valves

Although certain of these items are similar to, or even the same as, those used for DX system installations, it is important to note that there are certain crucial differences.

Piping

Piping for Secondary systems can utilize many different types of materials and joining technologies. Most of these can be used as long as they comply with temperature and pressure ratings, material compatibility requirements, and local codes and regulations.

Among the greatest differences between materials used for conventional and Secondary refrigeration is the use of ABS plastic piping. Although not an option for conventional refrigeration, certain engineered plastic piping systems are



entirely suitable for Secondary applications. These systems are ones that have been specifically developed to meet all pressure,



temperature and material compatibility requirements of Secondary refrigeration. Hillphoenix recommends piping from Georg Fischer Piping Systems. Information about those systems is available from the manufacturer.

Although from a cost benefit perspective, plastic piping may be the most effective choice for Secondary refrigeration, some customers

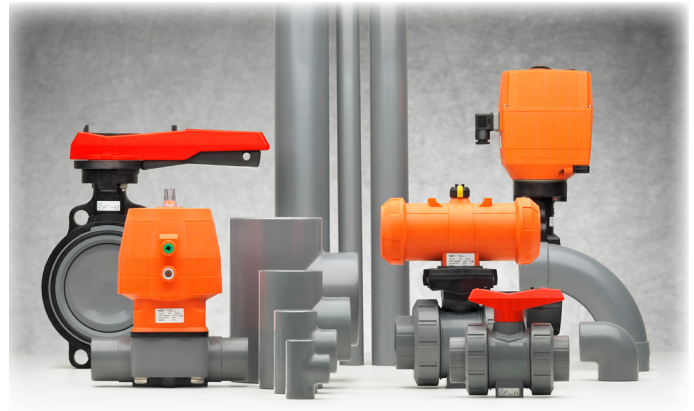

will choose to use copper pipe which continues to be an option. If copper pipe is used, it must be water grade (type M) or heavier and with standard refrigeration brazing or soft solder. Many valves and other components designed for use in fluid systems cannot withstand typical brazing temperatures and must only be soft-soldered. Hillphoenix only approves of the use of Stay-Brite® or Silverbrite® solders used with water-soluble flux that does not contain zinc.



Piping Supports and Insulation

Both engineered plastic systems and copper tubing can be used for applications in which the piping is run overhead on hangers and other types of supports. In the case of plastic piping, a greater number of supports may



be necessary to prevent the piping from sagging due to the flexibility of the piping materials and the weight of the coolant that it carries. The piping manufacturer's guidelines should be followed to determine proper support spacing.

When supporting insulated pipe, a saddle with a smooth bearing surface that is at least three pipe diameters wide, and able to cradle 120° of the pipe should be used.

Insulation

Insulation is used with refrigeration piping in order to reduce heat transfer between the fluid lines and the surrounding ambient conditions. It also is used to prevent condensation or ice formation on the surface of the pipe and to reduce corrosion of the piping material.

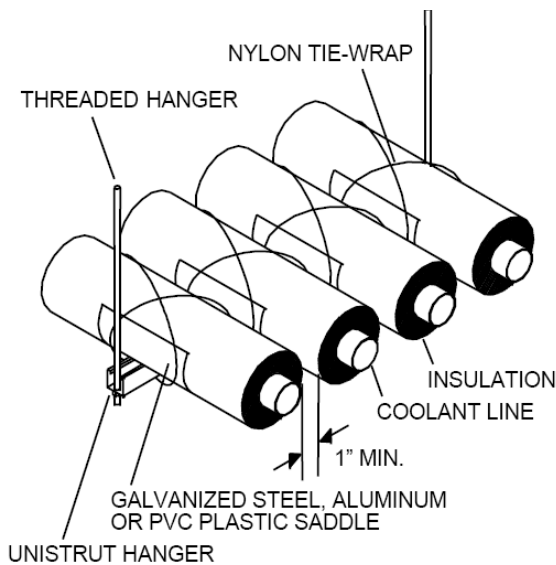

All valves, controls, and fittings in contact with Secondary coolant should be insulated in a way that facilitates easy removal of the component for servicing. The reason for insulating these components is to minimize air pockets or voids that can, over time, collect moisture and lead to the malfunctioning of the component.

Thickness requirements for insulation can be minimized where possible, by avoiding the placement of piping in non-air-conditioned spaces. Outdoor placement of insulated piping should also be avoided as exposure to UV light degrades most closed-cell rubber materials over time.

General guidelines for the proper insulation thickness to be placed on secondary piping under different conditions is provided in the table that is shown shown on the top of the next page. Note that Hillphoenix recommends that Normal Conditions be used as a guide for sizing of pipe insulation.

PIPE SIZE	MILD CONDITIONS 80°F Dry Bulb 50% RH, 0 fpm	NORMAL CONDITIONS 85°F Dry Bulb 70% RH, 0 fpm	SEVERE CONDITIONS 90°F Dry Bulb 80% RH, 0 fpm
3/4"	3/4"	1"	2"
1"	3/4"	1"	2"
1-1/4"	3/4"	1"	2"
1-1/2"	3/4"	1-1/2"	2"
2"	3/4"	1-1/2"	2"
2-1/2"	3/4"	1-1/2"	2"
3"	3/4"	1-1/2"	2"
4"	3/4"	1-1/2"	2"
5"	3/4"	1-1/2"	2"
6"	3/4"	1-1/2"	2"

Piping Guidelines

Of course the purpose of supporting pipes overhead and running them through the store is to create the refrigeration loop system that provides coolant to the cases and other connected loads and removes heat from them. Secondary piping is usually designed in a loop piping configuration. Another approach called circuit piping is generally used with conventional DX systems but only occasionally with Secondary applications.

In loop piping systems, two generally large pipes for the main supply and return lines run from the refrigeration system throughout the store. Off of these main lines, smaller branch lines connect to each refrigeration load.

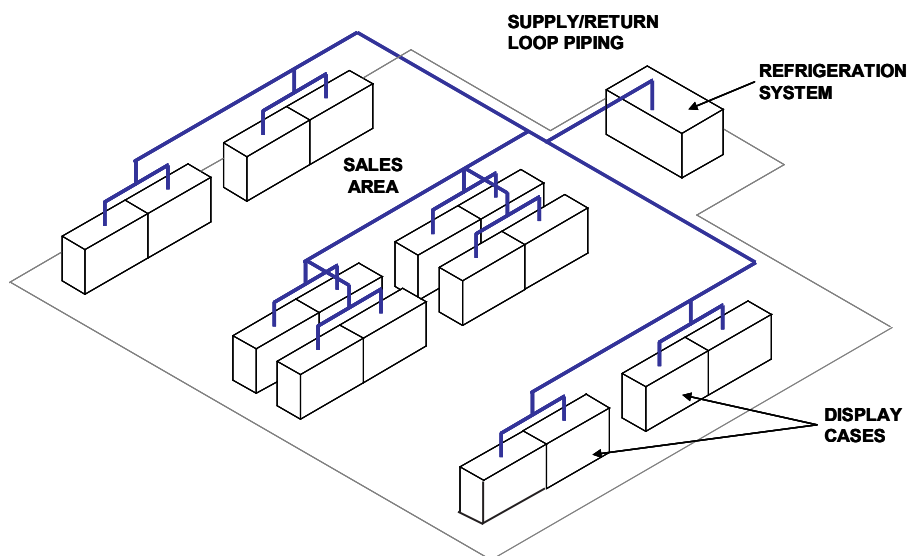

All controls and valves for refrigeration and defrost are located at or near the cases and coolers. In systems with warm fluid defrost, a third pipe for the defrost supply fluid is also run to each connected load. This type of system is referred to as a *three-pipe loop system*.

Regardless of the piping method used, a number of field-installed control valves are typically installed in Secondary systems. These include:

- Solenoid and check valves installed in cases
- Defrost valves and/or valve assemblies installed outside of cases
- Balance valves installed in return lines after the heat exchangers
- Solenoid valves that shut-off coolant during defrost that are also used to for temperature control

Always follow the valve manufacturer's specifications for the placement and orientation of all valves.

Piping for single display cases and walk-in coolers should include an isolation valve in the supply line (which may be part of a valve assembly), and a balance valve in the return line. Connections for draining Secondary fluid and venting air from the coil should always be installed if they are not already included from the factory. Typical piping for walk-in coils is shown in the diagram on the next page.

For lines running to multiple coils, such as in a line-up of display cases or a

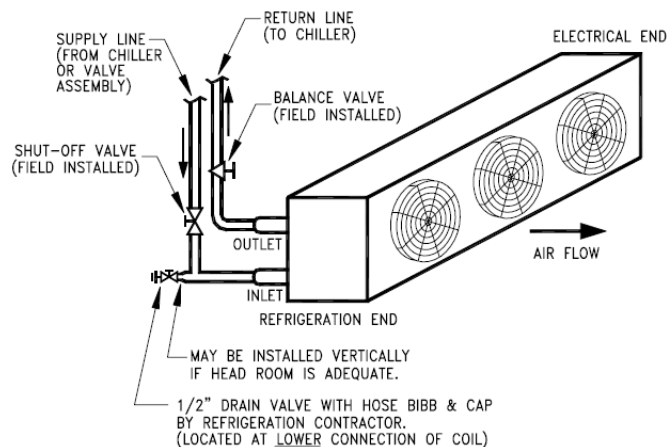

cooler with more than one fan coil, a method know as reserve return piping should be used. Reverse return piping makes the first coil connected to the supply header also be the last coil connect to the return header. This first-in, last-out piping helps to equalize the pressure drop across each coil and simplifies balancing the system.



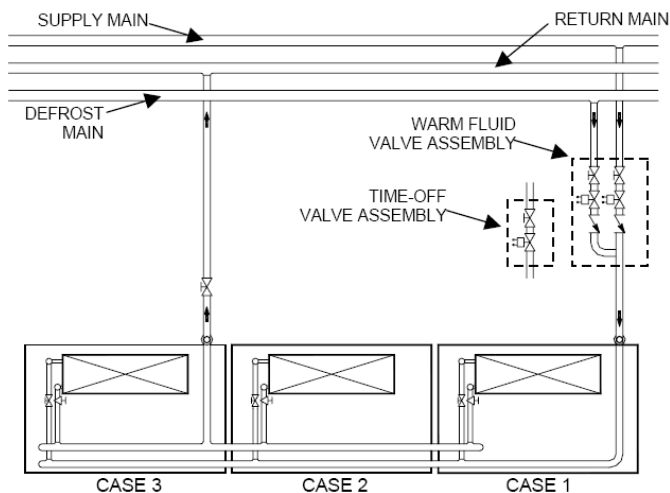

Reductions in case-to-case (coil-to-coil) piping can be made to reduce piping costs. When doing so, however, care must be taken to ensure that all requirements are satisfied.

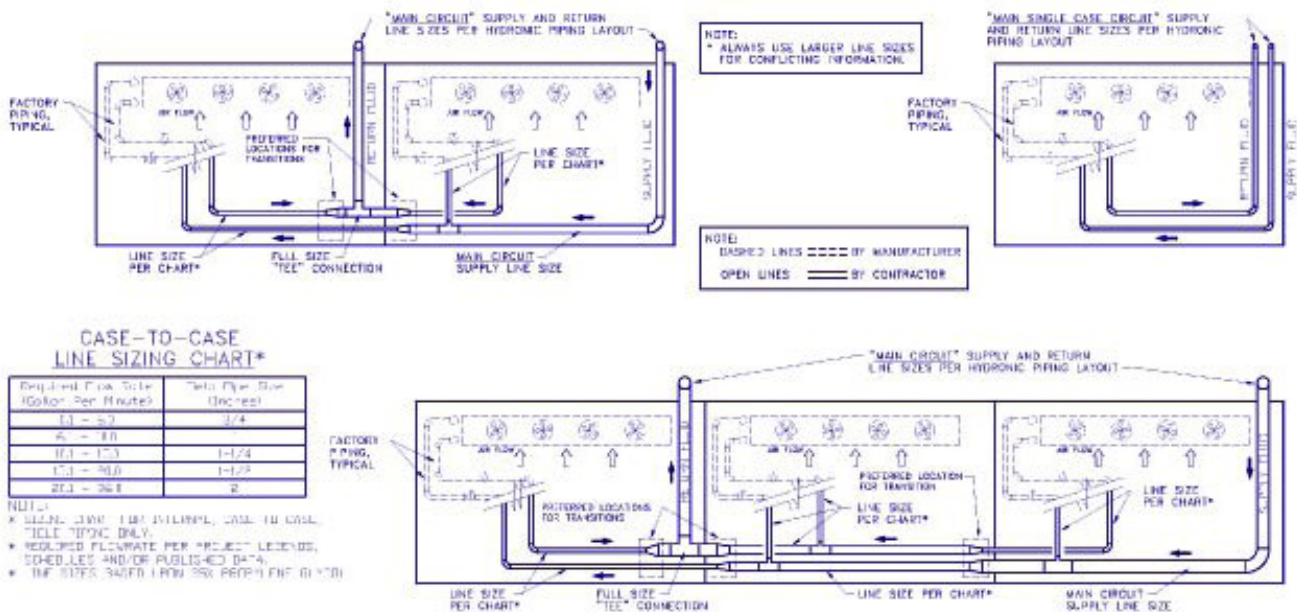

MEDIUM TEMPERATURE, SECONDARY COOLANT, INTERNAL CASE-TO-CASE PIPING DIAGRAM



A full page spread of the diagram is included at the end of this lesson.

General Piping Principles

These basic principles must be followed in piping refrigeration systems:

1. Always verify components



2. Adhere to legend line sizes and use only clean dry piping
3. Provide proper support and clamping to refrigeration lines
4. Properly braze joints
5. Insulate supply lines
6. Pressure test line sets



Some important points about each step are:

1. Verify components—positively confirm (as with all other aspects of the installation process) that all components match each other.
2. Adhere to legend line sizes and use only clean dry piping—the line sizes shown on the legend for the system should be adhered to; any discrepancies in the line size as well as the refrigeration loads must be brought to the attention of the customer and Hillphoenix.
3. Provide proper support and clamping to refrigeration lines—line breakage must be avoided on all lines and particularly on long, straight runs where types of hangers must be used that allow for longitudinal movement of piping and, as a result of closer placement to reduce sagging and vibration; all piping must be adequately supported with hangers that can withstand the combined weight of tubing, insulation, valves, and coolant in the tubing.
4. Properly brazed joints on copper lines—all joints must be brazed according to the customer's specification after being thoroughly cleaned. Dry nitrogen at 1/2 psi must be flowing through the tubing while joints are brazed to avoid internal scale buildup. Limit the soldering paste or flux to the minimum required to prevent contamination of the solder joint internally, Flux only the male portion of the connection, never the female. After brazing, remove excess flux.

5. Insulate supply and return lines—use only material listed in the customer specification. Insulation must be thick enough to keep heat from getting in and moisture (sweating) getting out.
6. Pressure test line sets—use dry nitrogen to test for leaks in brazed joints to confirm they are able to hold pressure. Always take care not over-pressurize any components.

Vents, Drains, and Branch Connections

Vents must be placed at all high spots in the system without exception. Anytime there is a vertical rise followed by a turn down a vent is needed. Likewise, drains must be placed at all low spots. Failure to follow these practices can result in severe problems for the system.

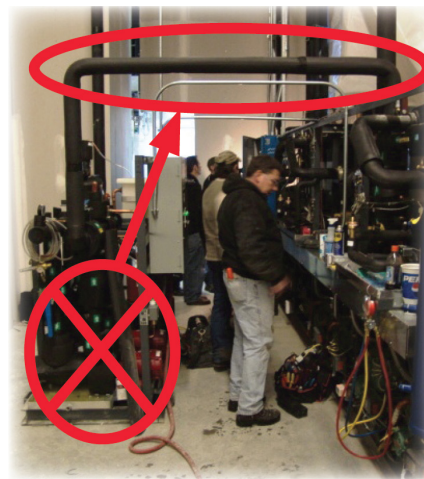

Needed vent not installed



Needed vent properly installed

Even when there are higher pipe runs nearby, as in the photo on the left, whenever a rise is immediately followed by a fall, a vent must be installed.



Drains are just as important.

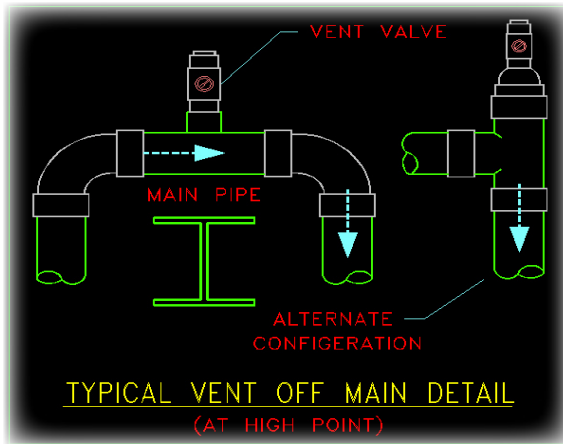

Vents

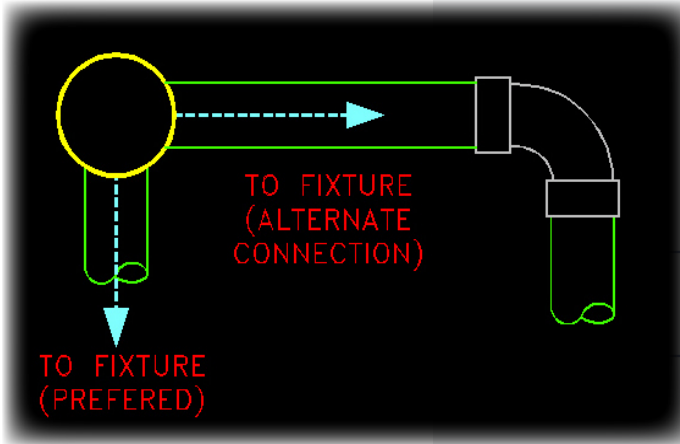

Branch Connections

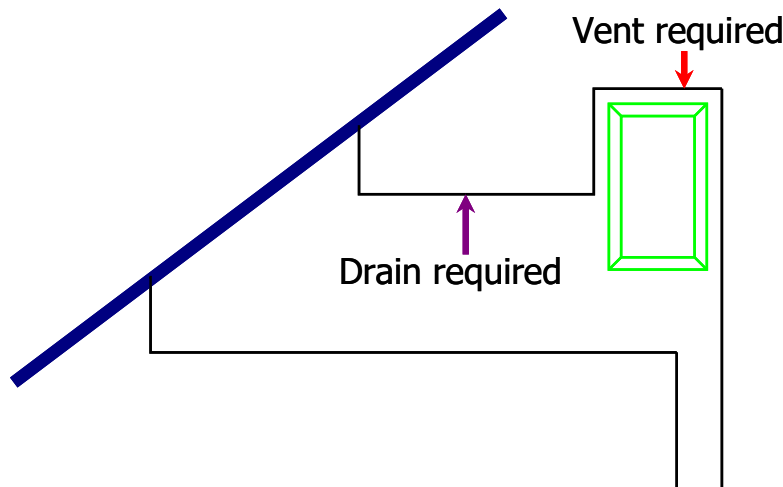

End of Loop Transducer

The system relies on a specially designed transducer that is field-installed at the end of each loop once the piping is in place. Along with the transducer, there is also a flow sensor that must also be installed with it.



Flow Sensor

The steps for installing the flow sensor are:

1. Flow Sensor (flow sensor spool) should be installed in the return line just prior to the pump station. Alternate locations (i.e. supply line) may be used as long as proper pipe runs are provided.
2. Attention must be paid to the directional indications for proper installation.

3. A minimum of 10 pipe diameters upstream and 5 pipe diameters downstream of straight, unobstructed pipe should be adjacent to the installation location.
4. The flow sensor should be installed in an upright position (no more than 45° around circumference from top dead center). Any circumferential location is correct for installation in vertical pipes.
5. Flow sensor signal wires should be routed to the pump station control panel and connected at field connection terminals, labeled for flow sensor. (Note: Standard sensors are supplied with 20 feet of 2-conductor 20 AWG shielded U.L. type PTLC 105°C cable).
6. Make sure to pay attention to the polarity of the signal wires from the flow sensor.

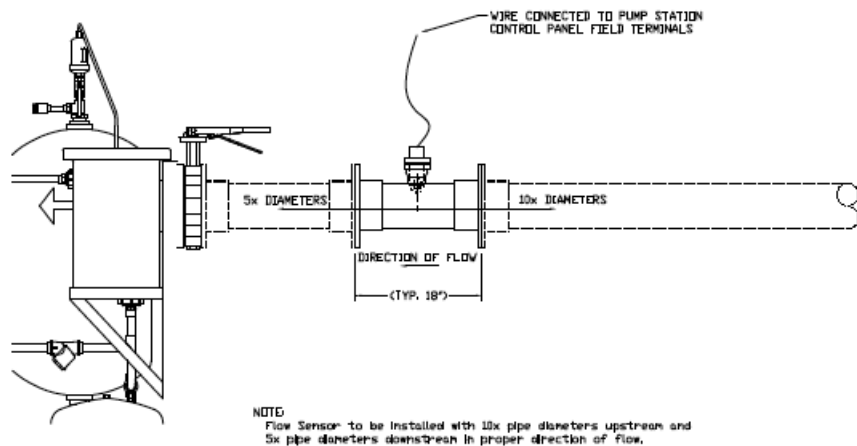

Loop Differential Pressure Transducer:

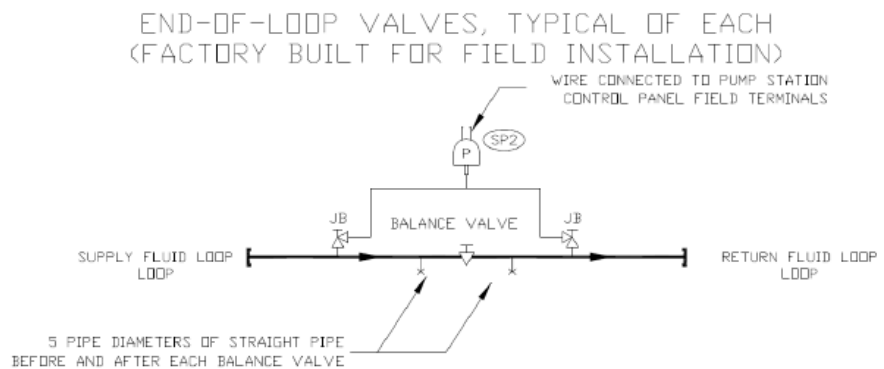

The steps for installing the loop transducer are:

1. The loop transducer (loop transducer/balance valve pipe) must be installed at the end of each loop, connecting supply and return pipes.

2. Make sure to pay attention to the directional indications (high and low side) for proper installation.
3. The differential pressure transducer signal wires should be connected at pressure transducer terminals with the polarity correctly matched.
4. The differential pressure transducer signal wires should be routed to the pump station control panel using a single, non-spliced cable and connected at field connection terminals, labeled for each loop transducer.
5. Make sure to correctly match the polarity of the signal wires from the loop transducer.

Loop Pressure Transducer Cable Recommendation and General Specification:

Stranded conductors, polyethylene or PVC insulation, (2) twisted pair, overall foil shield (100% coverage), separate drain wire, with PVC jacket. Cable suitable for process control or instrumentation.

Type: NEC/UL PLTC or NEC/UL CM or equivalent

Distance ¹	Size/Type	DC Resistance	Cable Reference
≤ 500Ft	22AWG/PLTC or CM	≤17.5Ω/1000 Ft.	Belden 9322, 8761 or AWC 6988-600
≤ 750Ft	20AWG/PLTC or CM	≤9.5Ω/1000 Ft.	Belden 1033A or Belden 8762
≤1500 Ft.	18AWG/PLTC or CM	≤6.5Ω/1000 Ft.	Belden 1032A or Belden 8760
> 1500 Ft.*	16AWG/PLTC or CM	≤4.5Ω/1000 Ft.	Belden 1035A or Belden 8719

Cable Recommendations (4-20mA, 24VDC signal)

Notes: One way cable length to transducer location.

* For distances > 2000 Ft. please consult factory.

Wrap Up

Proper installation of refrigeration systems is critical to the safe and efficient operation of those systems. The extensive variety of materials practices required for most installations means that these can be demanding jobs. Contractors must be sure to always use the right materials and perform the proper practices to ensure successful installations.

Coming Up

In the next lesson, the specific steps necessary starting up a HillPhoenix Second Nature™ system are explained. A checklist is also provided for conformation of the steps.

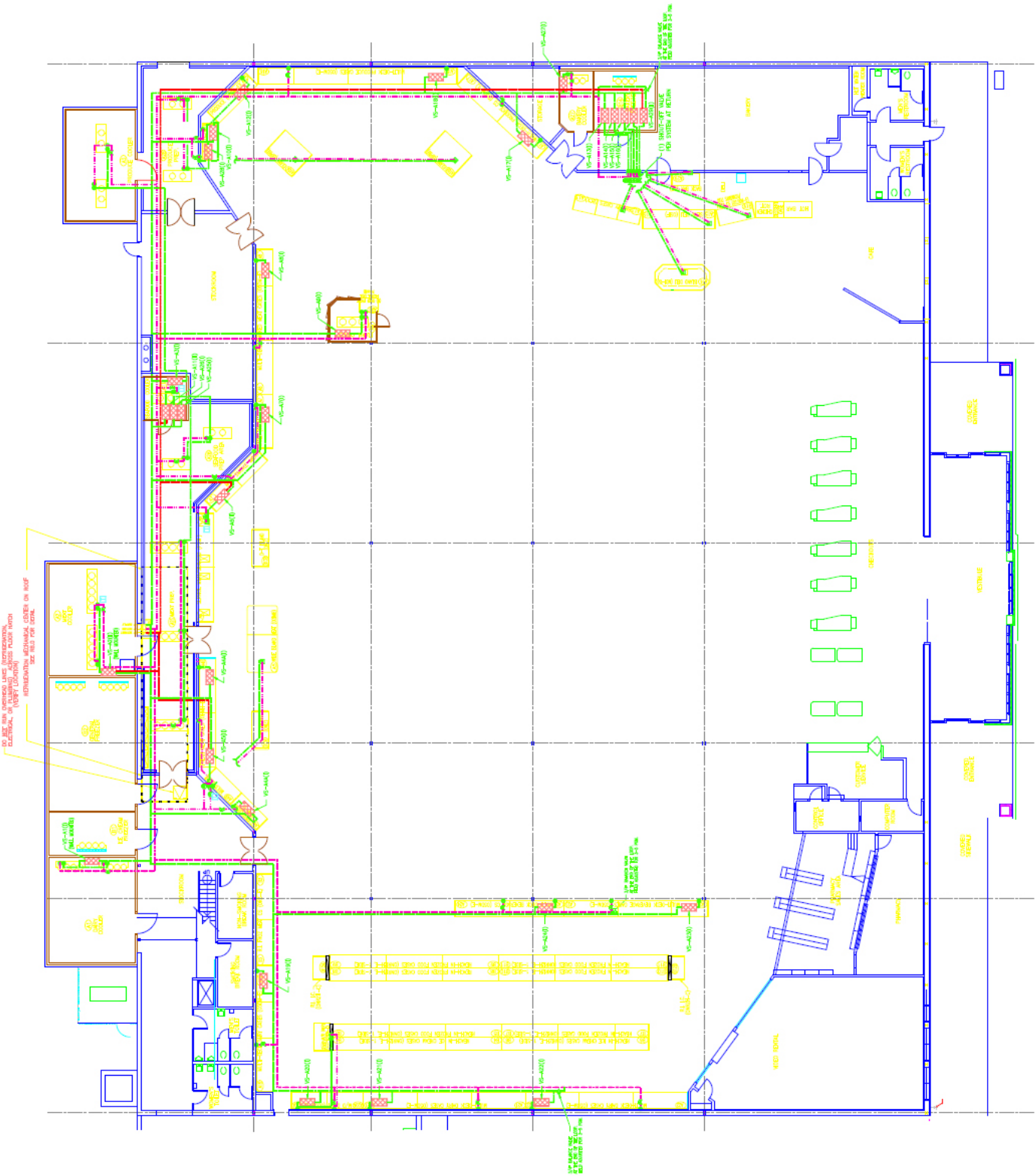

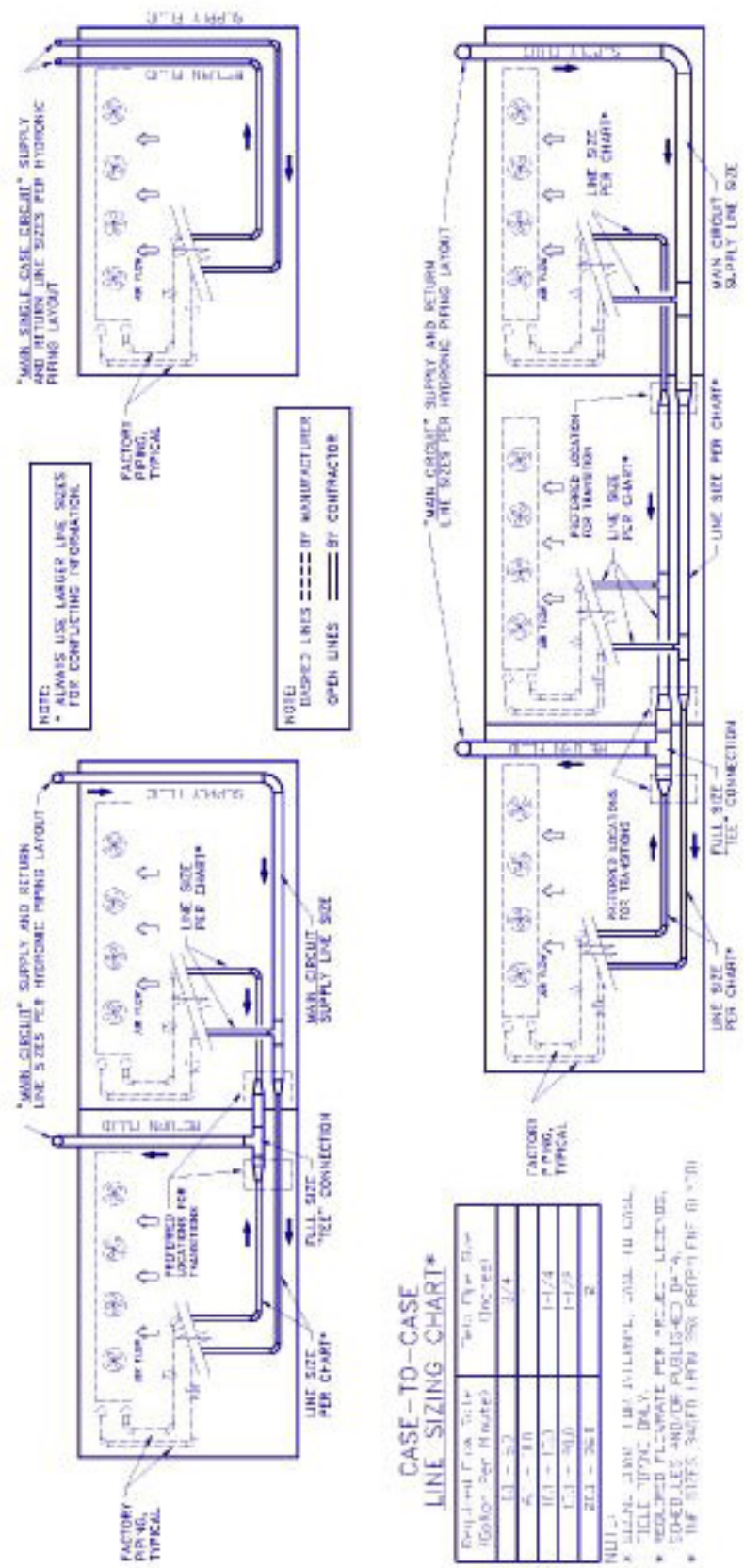

1
R4.2

MEDIUM TEMPERATURE, SECONDARY COOLANT, INTERNAL CASE-TO-CASE PIPING DIAGRAM

**Lesson
3**

Secondary Startup Procedures

Because Hillphoenix warrants all of the refrigeration systems and equipment it manufactures, it is essential that all systems be properly started up. The procedures presented in this lesson describe the startup practices for Hillphoenix Second Nature™ refrigeration systems and equipment.

Careful execution of the start-up procedures for any refrigeration system is critical to the safe, effective, and efficient operation of the system. Every step must be followed in as much as possible the order and the way described in this guide, otherwise the equipment may not function properly. It is also critical that only the materials specified in the procedures be used.



Handwritten notes area with horizontal lines.

Objectives

By the end of this lesson you will be able to:

- Describe the initial startup procedures for a medium temperature Secondary system.
- List the steps for adding fluid to the system.
- Describe the controls strategy for the system.

It is important to note that these procedures are intended only as guidelines to be followed as closely as the specifics of each installation allow.

The step-by-step Start-Up Guide on the next page walks through each step of the start-up process. At every step the specific tasks that make up the step are listed with specific settings where they apply. You may find it helpful to refer back to the Start-Up Guide as you learn about the procedures involved in starting-up a Hillphoenix Second Nature™ system.

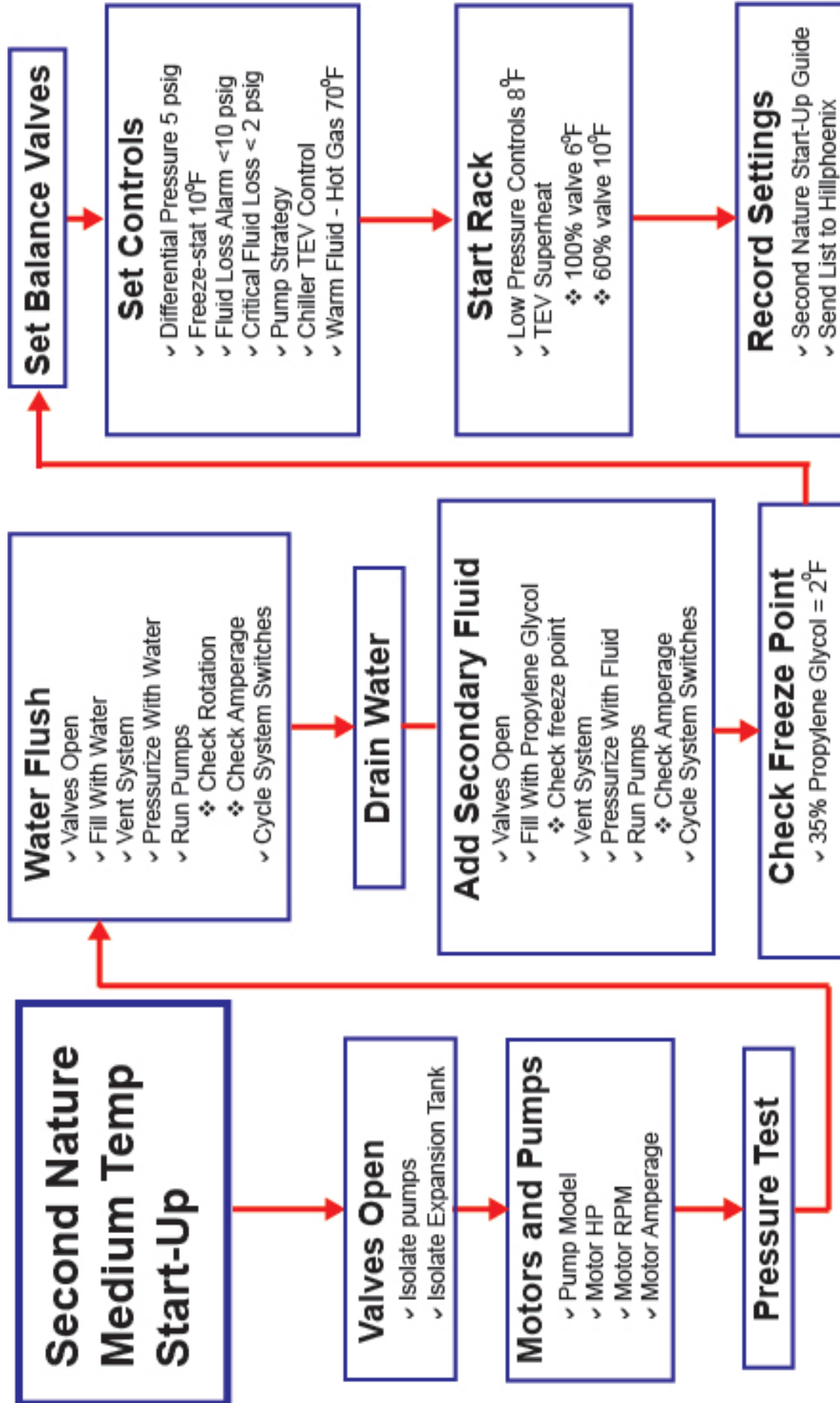

Startup Guide

The initial startup procedures begin with setting the end-of-loop balance valves.

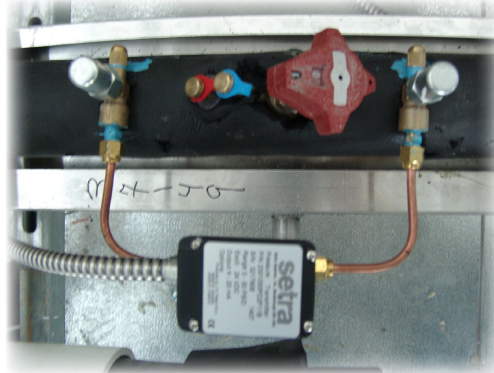

End of loop balance valve give the system constant flow even when there is no call for cooling. Set ¾ inch end of loop balance valves at 1.0. (Note: This is the only reference to the end of loop balance valves in these procedures. From this point on all discussion of balance valves only pertains to ones elsewhere in the system.)



The next step is to verify that the control circuit is energized and to fully open all:

- Balance valves
- Ball valves
- Solenoid valves

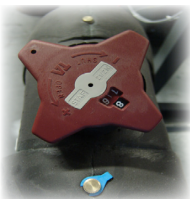

Once the valves are open, close all vents and drains.

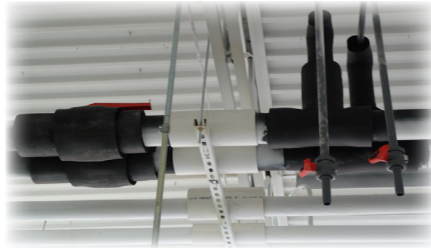

With all of the balance, ball, and solenoid valves open, and the drains and vents closed, verify that the pre-charge pressure in the expansion tank is at 15 psig and adjust as required.

Pressure Testing

At this point, pressure testing the piping can begin by isolating:

- The expansion tank
- The pumps
- Any cases and/or components that are not rated for the test pressures that will be used



Use dry nitrogen, at the following durations and settings, once the expansion tank, pumps, and non-pressure test-rated cases and components have been isolated.

1st 30 minutes	15 psig
2nd 30 minutes	30 psig
1 to 3 hours	60 psig
Reduce to 15 psig if pressure charge is left on	

Flushing the System

Following pressure testing of the piping, the system is ready to flush:

- a. Open all system valves (including any closed in the preceding step).
- b. Close a valve between the return and the supply on the pump skid in order to break the chiller loop which results in a



one-way flow through the system.

To create a one-way flow, connect the drain hose to the return side of the system and the supply hose to a point on the opposite side created by the closed valve.



- c. Fill the system with water to normal service pressure and allow water to flush through the drain until water runs clear.

Note: All references to water assume acceptable quality regardless of source.

- d. Stop draining water.
- e. Open the valve referred to in step (b.) above.
- f. Relieve pressure on the system to approximately 30 psig.
- g. Vent the main loop lines to ensure loop is full of water (note: the number of loops may vary from system to system).



- h. Vent air from the system starting at the lowest vent points and moving continually to higher vent points until all air is purged from system including main vent lines.

Lowest vent points are typically coils— all coils must be purged of air.

Remember to monitor and maintain approximately 30 psig water pressure through the system.

Make sure to also purge air from pump skid since it is also part of the system.

- j. Turn off the water supply.

With the system pressure tested and flushed, the pumps can now be started.

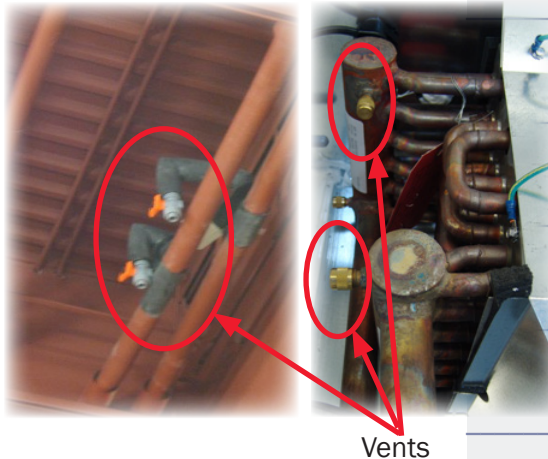

Vents

Pump Start-Up

Start the pumps by:

- a. Verify that the correct pumps (model number, and motor hp, rpm, voltage) are installed.

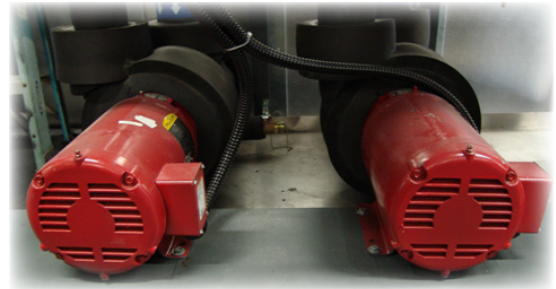

The pump curve

provided by Hillphoenix indicates model number, horsepower, and rpm.

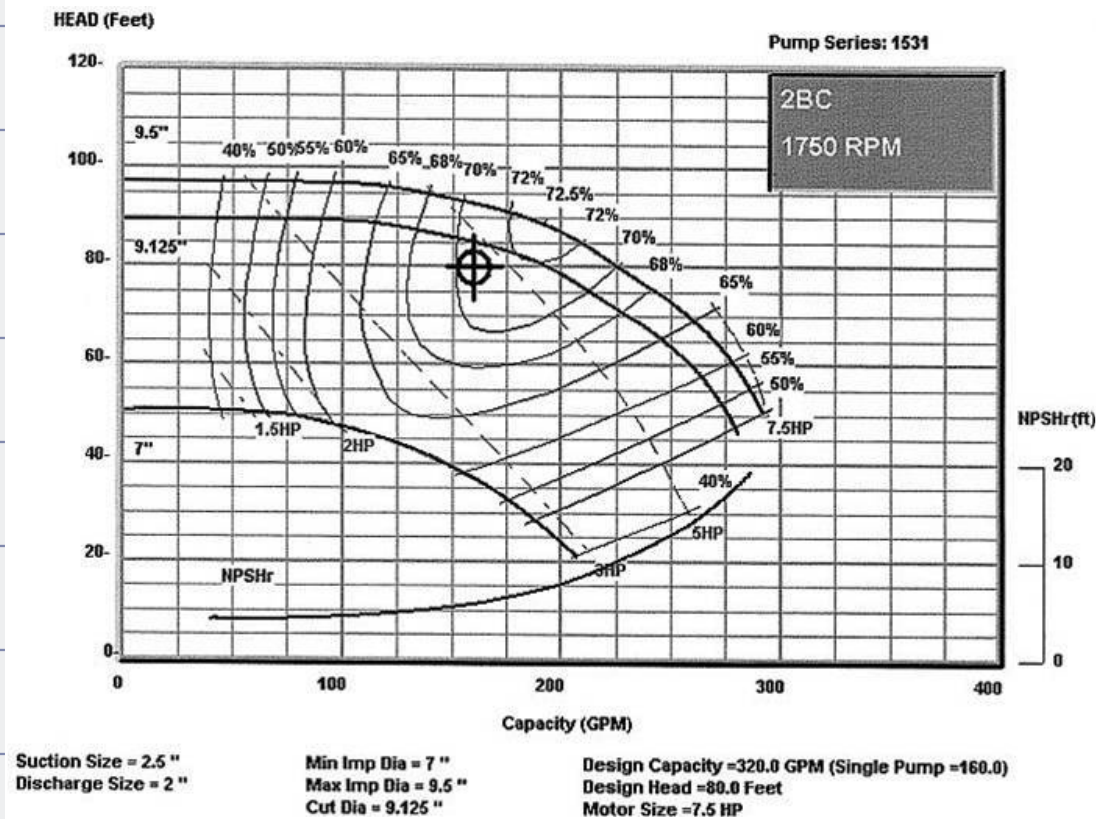

- b. Verify pumps are full of water by venting. **Never run pumps dry as seal damage will occur.**

- c. Manually cycle pumps on and off one at a time to determine the direction of rotation is correct.

- d. Start the pumps one at a time and check amperage for each pump. If the amperage is too high reduce it by closing the pump outlet balancing valve until the proper amperage is reached.



From this point on, maintain the return fluid pressure at 15 psig by adding water as needed

- e. Cycle the system switches so that each of the circuits is the only one turned on for a period of 1 minute to fully flush each coil.
- f. Cycle on and off the warm fluid (WF) defrost solenoids.
- g. Turn on all of the systems and allow the water to circulate for 2 hours. Shut off the pumps when done.



At this point the system can be drained.

Draining the System

Keep in mind that once water is in the system it should never be drained until the system can immediately be filled with Secondary Fluid.

Drain the system:

- a. Shut off the pumps.
- c. Drain all water from all drain points in the system and force out any water remaining with dry nitrogen.
- d. Check the drain water for cleanliness; repeating the flush process if the drain water is dirty.
- e. Open the pump strainers and removing the fine-mesh startup screen from around the outside of the permanent strainer and reassembling without the startup screen.

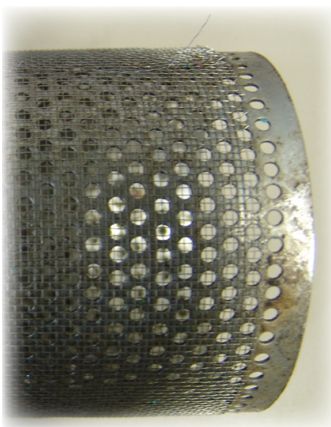

With the system drained, Secondary fluid can now be pumped into the system from the tank or barrel (drum) in which it is contained.

Filling the System

Pump Secondary fluid into the system:

- Open all valves (but do **not** open vents and drains).
- Use a Refractometer to check the freeze-point of each drum (tank or barrel) before installing into system.
- Pump two drums (or the equivalent amount from a tank or barrel) of 35% Secondary Fluid into the system.
- Pump one drum (or the equivalent amount from a tank or barrel) of 100% Secondary Fluid into system.
- Finish filling the system with Secondary fluid in as much the same way as when filling system with water.



Do not discard any Secondary fluid—any Secondary fluid that is purged from system should be returned to the fill tank to be reinstalled into system.

- Purge all of the air from system in much the same way as when the system was filled with water.



Note that any Secondary fluid purged with the air is kept and can be returned to the system via the fill tank.

Then restart the pumps:

- Verify that the pumps are full of fluid and all air has been removed.
- Verify that the pump balance valves are completely (100%) open.
- Start the pumps one at a time and check the amperage for each pump.

Note: if any of the pumps are over amperage, close the pump outlet balance valve until the proper amperage is again reached.

- From this point on, maintain a return pressure of 15 psig by adding Secondary fluid as needed.

Starting Up the System

Start and run all pumps:

- a. Allow the fluid to circulate, maintaining a return pressure of 15 psig.
- b. Check the freeze-point of the system fluid using the Refractometer.
- c. Cycle system switches so that each system is the only one turned on at a time for a period of 1 minute each to fully fill each coil.
- d. Repeat checking the freeze-point of the system fluid.
- e. Turn on all of the systems and allowing them to circulate for 1 hour.
- f. Check the fluid freeze-point for the system once more.



If the freeze-point is too high—use 100% design fluid to adjust when adding to system.

If the freeze-point is too low—use water to adjust when adding to system.

After the system is charged with fluid, adding additional coolant should be done using the fill tank.

- g. Record the final freeze point.

Adding Fluid to System Using the Fill Tank

- a. Add fluid to the fill tank making sure not to fill the tank above the overflow.

Never add water to the system with the chillers on.

- b. Locate and slowly open the ball valve between the fill tank and the pump inlet line.

Never let a pump pull air into the system through the fill tank.

- c. Slowly close the pump return ball valve when a pump no longer pulls fluid from the fill tank.



Secondary Installation, Startup, Maintenance and Troubleshooting

Hillphoenix Learning Center

Lesson 3 - Secondary Start-Up Procedures

If a return pressure of 15 psig cannot be obtained, shut off the other pumps and try again with only the pump to which the fill system is connected running.

Always shut the ball valve between the fill tank and the pump inlet valve (referred to above) when finished.

Compensate for contraction as the system cools to operating temperature by adding more fluid.

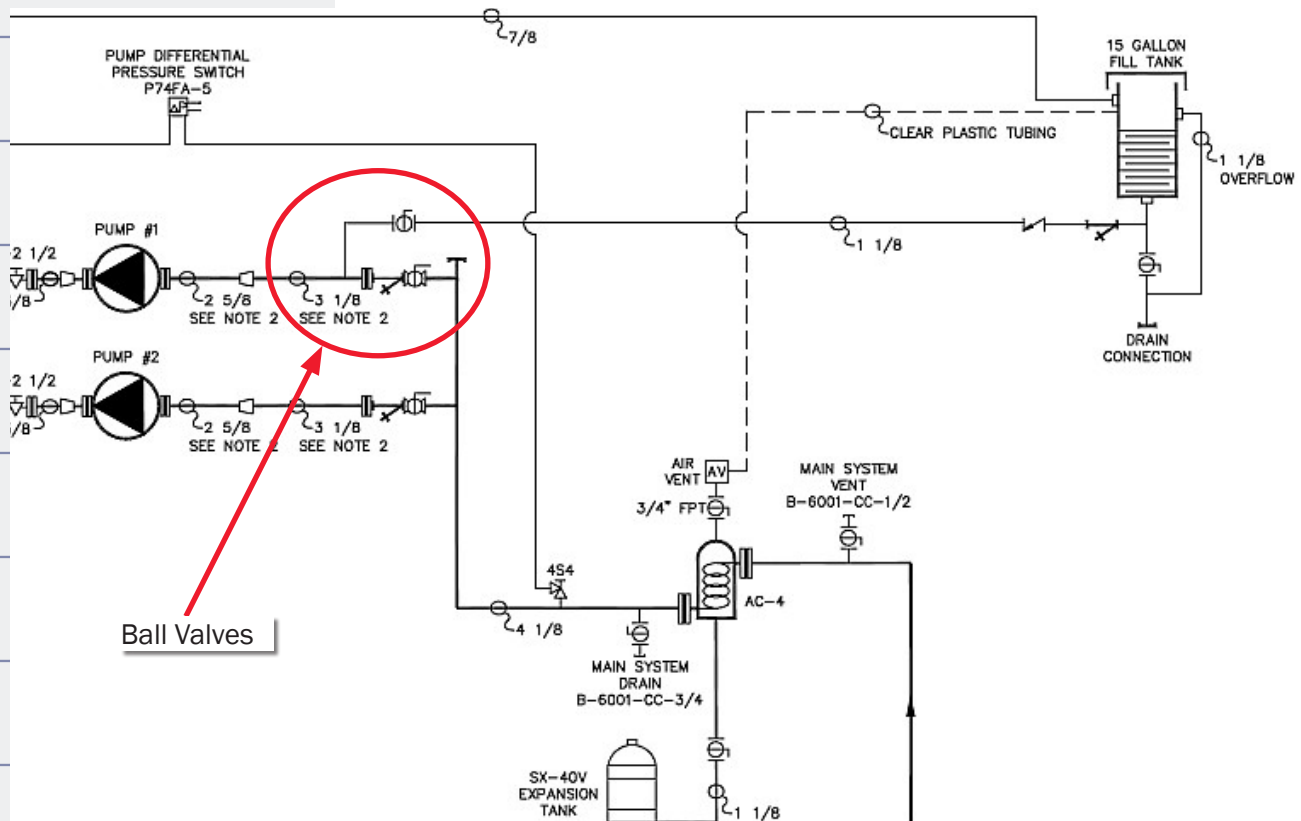

A full page spread of this diagram is included at the end of the lesson.

Balance Valve Setup

Balance valves can be set using either a flow meter or any approved method from the valve manufacture. To find the correct flow rates, refer to the system legend.

- Determine the individual valve set point using the legend.



- b. Set the valve accordingly at each display case and walk-in.
Adjust setting as need for proper discharge air temperature.
- c. After setting the valve to the proper flow rate lock the setting in place.

Controls Strategy

All Temperature Values in °F					Sample Target Temperature in °F			
		Calculate from desired target (float) temperature		Probe	20		24	
		Cut-out	Cut-in		Cut-out	Cut-in	Cut-out	Cut-in
Chiller #1	Chiller Enable	- 6	- 2	Chiller #1 outlet	14	18	18	22
	60%	- 6	- 1	Main Supply fluid	14	19	18	23
	100%	even	+ 2		20	22	24	26
Chiller #2	Chiller Enable	- 4	- 1	Chiller #2 outlet	16	19	20	23
	60%	- 3	+ 1	Main Supply fluid	17	21	21	25
	100%	+ 1	+ 3		21	23	26	27

TEV Solenoid Set points

Establish an effective controls strategy through the following steps:

- a. Set the pressure relief valve on the pump station to 75 psig.
- b. Set the differential pressure control for 5 psid and check for operation by shutting off the pumps.
- c. Verify that there is thermal grease in the probe well.
- d. Set the freeze-stat to turn off the liquid line solenoid at 10°F with a 5°F dead band.
- e. Verify the freeze-stat operation by confirming that the Freeze-stat Alarm Light Lock-on works correctly.
- f. Verify that the rack low pressure switches are set to pressure equivalent to 8°F.
- g. In the controller, verify that the Fluid Loss Alarm is set for when the

return fluid pressure reaches < 10 psig.

- h. Also in the controller, verify that the Critical Fluid Loss Alarm (this setting also locks out the primary pump—the one with the fill tank attached) is set for when the return fluid pressure reaches < 2 psig.
- i. Verify that all setpoints in the controller for case temperatures, alarms, defrost times and termination temperatures match the manufacturer's specifications

Noting any variations from manufacturer's specifications

- j. Set Rack Floating, using a common supply fluid probe, for the desired target temperature °F with a pressure float of + 6 psi.

Warm Fluid Defrost System

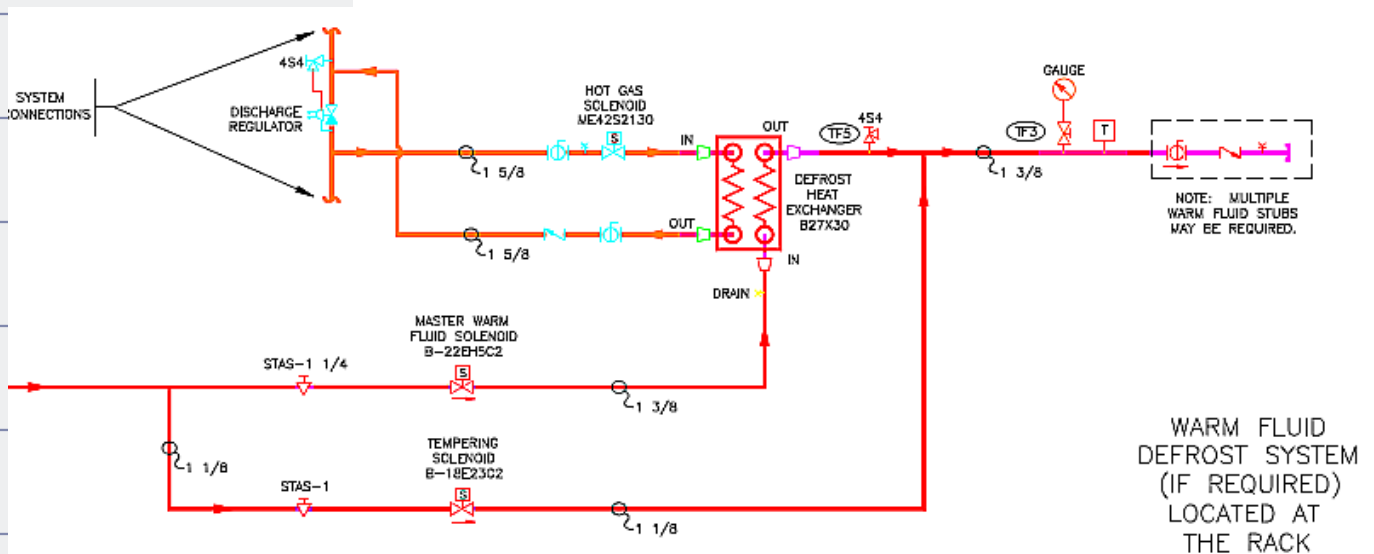

A full page spread of this diagram is included at the end of the lesson.

Set up the warm fluid defrost system through the following steps:

- a. Set master the warm fluid balance valve to ½ of the flow of the largest system that requires warm fluid to a maximum of 12 GPM
- b. Operate the hot gas line solenoid valve controlled from the warm fluid outlet probe

Maintain fluid to store between 65°F and 75°F

Note: Cut-In and Cut-Out may need to be lower to maintain a maximum fluid temperature of 75°F

- c. Set the defrost differential valve to meet the temperature requirements of largest GPM warm fluid defrost system.

Pump Strategy

Record the listed flow rates for the type of pump control used with the system.

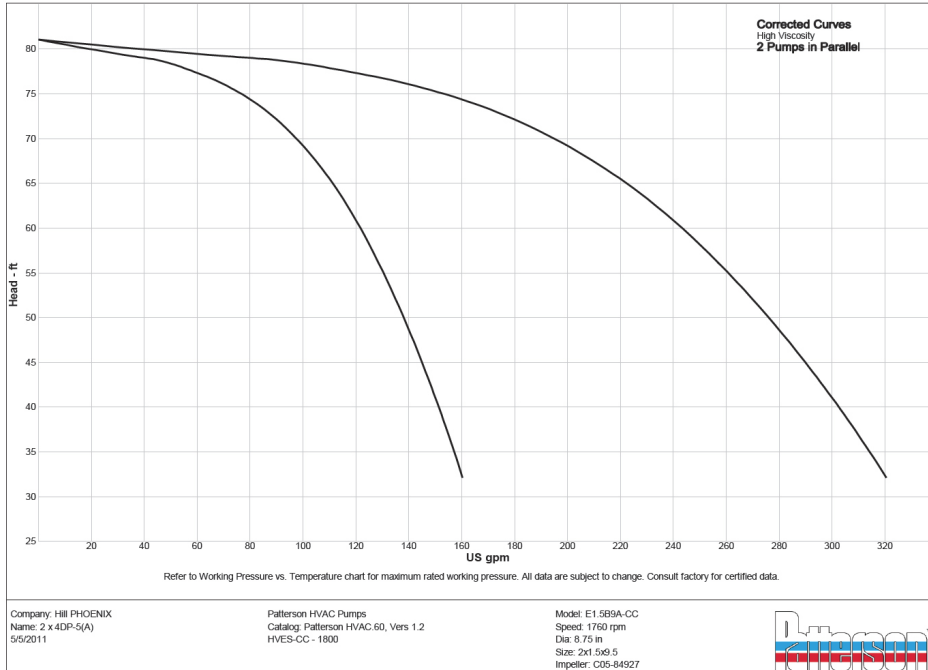

2 Pump control

- A. 100% flow – 2 pumps on _____ psi differential
 - B. 100% flow – 1 pump on _____ psi differential
 - C. 90% flow – 1 pump on _____ psi differential
 - D. 70% flow – 2 pumps on _____ psi differential
- i. C = pump on
 - ii. D = pump off



System Operation

Final System Checks

After a couple of days of operation the system is ready for some final checks.

- a. Check all high vents for any trapped air and any other air trapped in system.
- b. Set superheat settings on Chiller TXVs:
 - i. 100% valve: 6° F
 - ii. 60% valve: 10° F
- c. Fine tune the balance valves inside individual circuits and adjust to give equal discharge air temperatures.
- d. Fine tune the system by finding the warmest fluid required to satisfy all the cases.



Wrap Up

Proper startup of refrigeration systems is critical to the safe and efficient operation of those systems. Contractors must perform the proper practices to ensure successful startups. Because Hill PHOENIX warrants all of the refrigeration systems and equipment it manufactures, it is essential that every job meets the customer's requirements. Startup checklists, like the one included at the end of this lesson, should always be carefully followed and checked upon completion.

Coming Up

Refrigeration systems, like any other type of machinery, require regular maintenance in order to operate safely and efficiently. Specific maintenance and troubleshooting procedures, therefore, have been developed to keep the systems running properly. In the next lesson, maintenance and troubleshooting procedures are discussed.

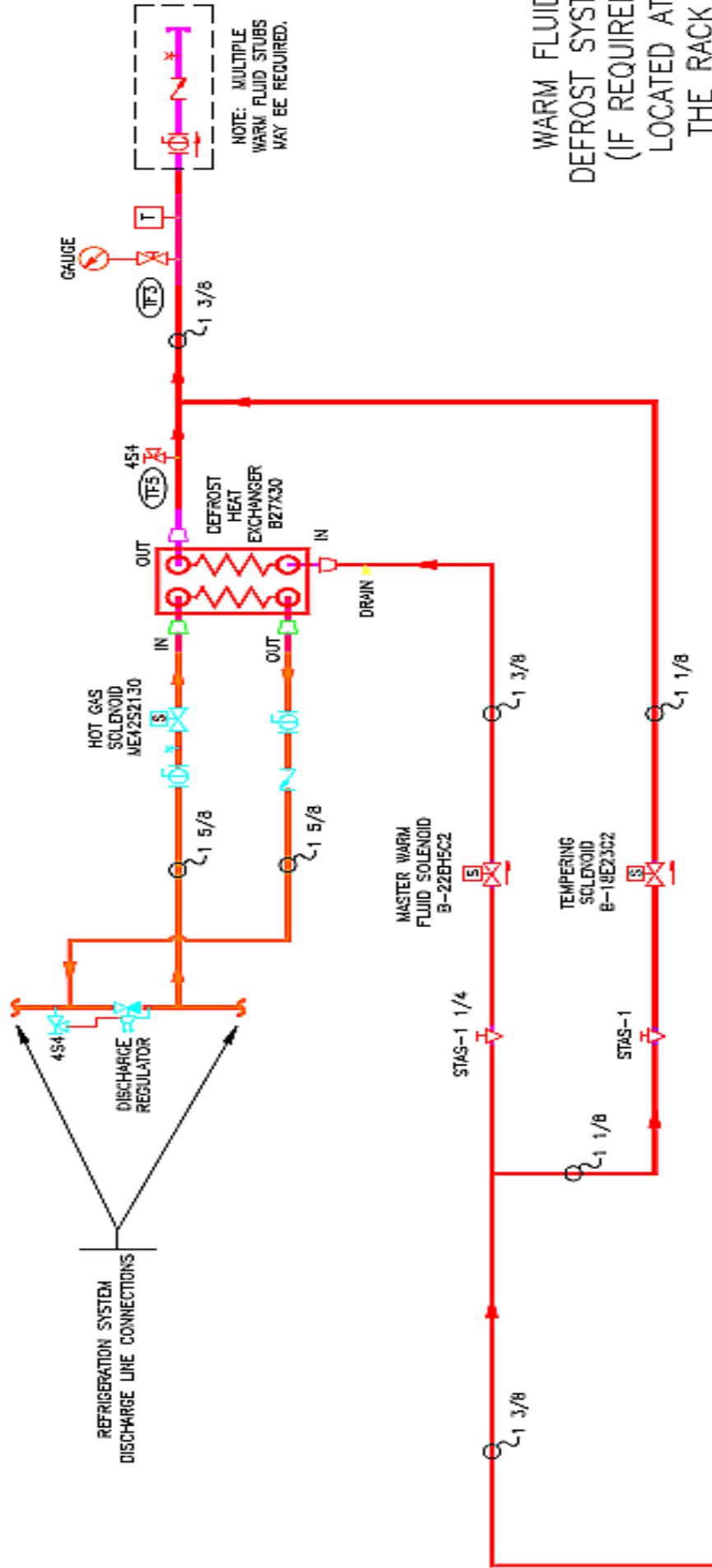

Lesson 3 - Secondary Start-Up Procedures

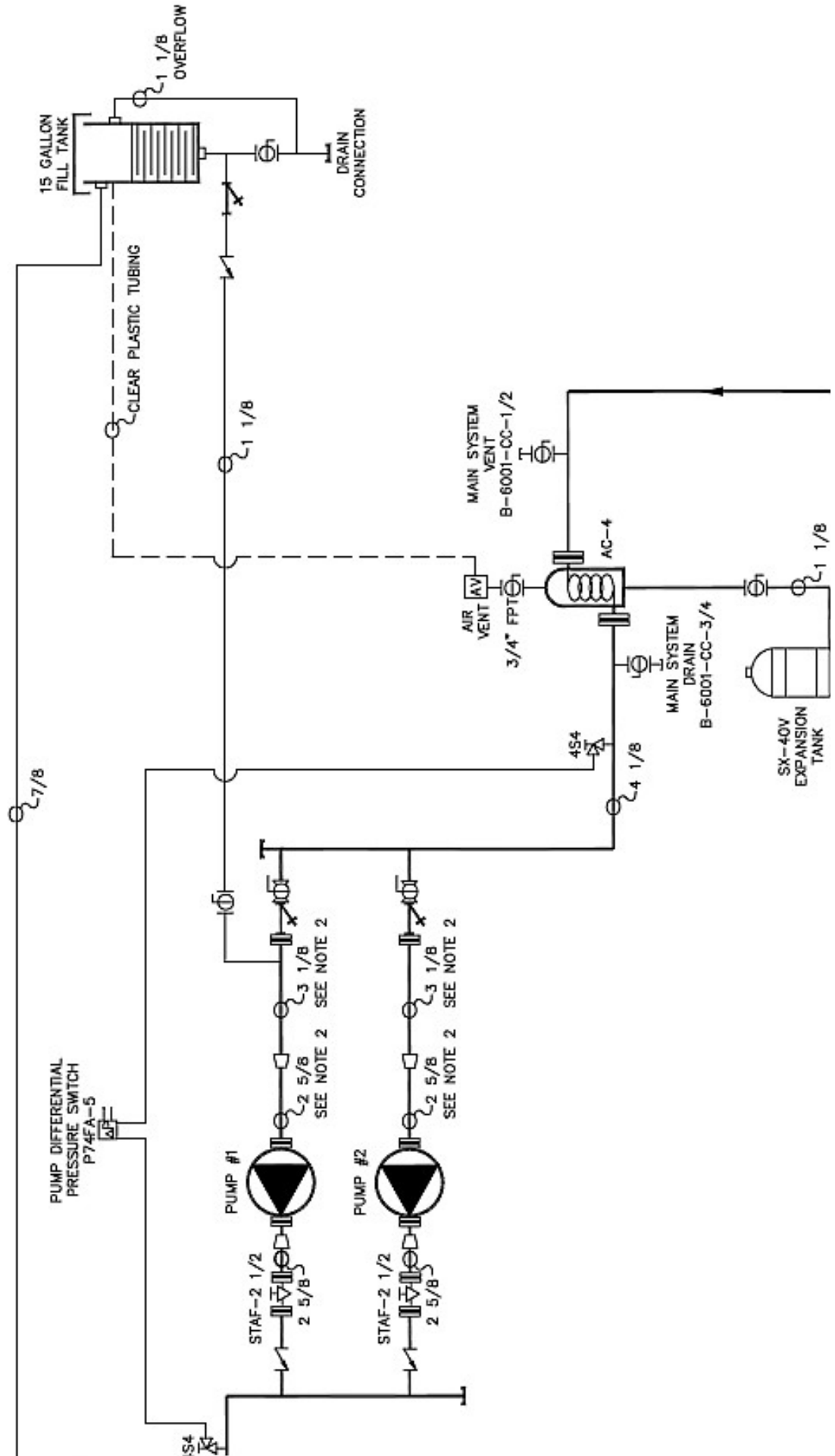

Hill PHOENIX Warranty Validation Checklist

This checklist provides space for confirming the settings, readings, and verifications you recorded in the guide. Sign and submit a copy of the completed checklist to Hillphoenix for validation of warranty coverage.

Mail: Systems Operations 2016 Gees Mill Rd. Conyers, GA 30013 Fax: 770.285.3085 Email: service@Hillphoenix.com Or: your local Field Service Engineer	Contact Information Technician performing checks: Name: _____ Phone: _____ Email: _____
---	--

1. Pump skid serial number _____

2. Pump #1 Nameplate Amps _____
 Actual Amps _____

3. Pump #2 Nameplate Amps _____
 Actual Amps _____

4. Pump #3 Nameplate Amps _____
 Actual Amps _____

5. Final fluid freeze-point of the system _____ °F

6. Balance valves confirmed set

7. Pressure relief valve on pump skid set to _____ psig

8. Expansion tank precharge pressure _____ psig

9. Differential pressure control set for _____ psid

10. Thermal grease verified in probe well

11. Enter these values:

Freeze-stat settings		
	Chiller #1	Chiller #2
Off	°F	°F
On	°F	°F

13. Fluid Loss Alarm set-point at _____ psig

14. Critical Fluid Loss Alarm set-point at _____ psig

15. Confirm pump lock-out operation

16. Verify all controller set-points match manufacturer's specs

17. List variations from manufacturer specs

18. Enter these differential pressure values:

	1 pump on	2 pumps on	3 pumps on
100%			
90% flow			
75% flow			
70% flow			
50% flow			

19. Enter these values:

	Chiller #1	Chiller #2
60% valve cut-in	°F	°F
60% valve cut-out	°F	°F
60% valve superheat	°F	°F
100% valve cut-in	°F	°F
100% valve cut-out	°F	°F
100% valve superheat	°F	°F

20. Hot gas line solenoid cut-in set-point _____ °F
 Hot gas line solenoid cut-out set-point _____ °F

21. Final supply fluid with all cases calling for (requiring) refrigeration _____ psig
 Final return fluid with all cases calling for (requiring) refrigeration _____ psig

Signature: _____ Date: _____

Lesson 3 - Secondary Start-Up Procedures

**Lesson
4**

Secondary Maintenance and Troubleshooting Procedures

Secondary refrigeration systems are complex arrangements of equipment and machinery involving numerous components spread among a variety of subsystems that provide refrigeration to the store's Secondary loops. In order to keep all this equipment and machinery running safely and efficiently, regularly scheduled maintenance must be performed. However, regardless



of how well-maintained the equipment may be, problems will occur from time to time. Like any other kind of machinery, and especially like other complex systems, something will eventually fail to work correctly. In those cases, there are troubleshooting procedures that aid in determining the causes of various problems. This lesson examines the maintenance and troubleshooting procedures for Secondary refrigeration systems.

Objectives

By the end of this lesson, you will be able to:

- Check safety and operating controls.
- Perform visual inspections on Secondary systems.
- Explain cleaning Secondary fixture coils.
- List troubleshooting procedures for Secondary systems.

Maintenance Procedures

Refrigeration equipment has been noted to account for approximately 50% of the total electrical consumption in the typical supermarket. In DX systems, for example, the compressors generally consume the greatest portion. As such, there is considerable potential for conservation measures to have a huge impact on the store's operating costs through the application of proper maintenance procedures.

Secondary systems have certain advantages over DX systems when it comes to maintenance:

- Only one 'evaporator' per rack with 2 expansion valves vs.. 50+ on a comparable DX rack.
- No regulators to adjust--the system balance valves are set once at start-up and do not regulate.
- Lower operating pressures--less than 50 psig vs. 250+ psig for DX.

Despite these differences, the maintenance and troubleshooting procedures for Secondary systems are, for the most part, essentially the same as for DX systems. There are, of course, a few key things to check that do not apply to DX systems, but otherwise all standard DX procedures should be followed.

Foremost among the maintenance procedures for Secondary systems is checking the system's safety and operating controls. The checks to be performed also include verifying that original settings are maintained.

Safety and Operating Controls

As should be clear by now, the safe and efficient operation of Hillphoenix Secondary refrigeration systems is of the utmost importance to the company, Therefore it is essential that the safety and operational controls installed on each system are functioning correctly. As part of the regular maintenance these should be checked at specific intervals.

Refrigeration systems include operating controls that cycle equipment on and off in order to maintain certain temperatures. They also require safety controls to stop operation if unsafe conditions occur. There are many varieties of controls. Different types work in response to temperature, pressure, humidity, liquid levels. and other inputs.

The basic controls on a Secondary refrigeration system govern the operation of three essential components:

- Pumps
- Chillers
- Evaporator (Secondary coil) fan motors

Pump Controls

The basic controls for pump operation are:

- Low temperature thermostats
- Pump differential pressure switches
- Liquid line solenoid valves
- System relief valves

In addition to these controls, a regular part of maintenance should be to verify that the pump cycling sequence is operating correctly.

Low Temperature Thermostats

Under certain conditions, the coolant can loose temperature and approach the freezing point. Any time the coolant reaches a temperature set point close to its freezing point, the *Low Temperature Thermostat*, or *Freeze-Stat*, turns off the chiller liquid feed solenoid valve. The set point for the Low Temperature Thermostat is typically in the range of from 5° to 7° higher than the coolant freezing point.

Without a means of guarding against the coolant becoming too cold, the chiller can end up freezing which could result in catastrophic failure of the system.

Pump Differential Pressure Switch

Because the Secondary side of the system relies on pressure to move the coolant through the system, the *Pump Differential Pressure Switch* is an important indicator that a pump is running and that a differential pressure has been created. Problems with temperature control at the case, can in some circumstances be traced back to a lack of differential pressure in the system. The Pump Differential Pressure Switch is one of the first things to check if the case is otherwise operating correctly.

Liquid Line Solenoid Valve

The *Liquid Line Solenoid Valve* isolates the chillers from the refrigeration system when energized. It performs as a mechanical backup to the freeze-stat in the event that the controller fails.

Pump Cycling Sequence

As a part of regular maintenance the pump cycling sequence should be verified for proper operation. Turn off and then on each refrigeration circuit to verify the pumps are cycling correctly.

DX Controls

In addition to the Compressor Low Pressure Switch, the standard DX system controls should always be inspected along with the Secondary controls.

These include:

- Thermostatic control (T-stat)
- High pressure control
- Compressor low pressure switch
- Oil failure switch

Explanations of these controls should be familiar to technicians experienced with DX systems. One of these controls, however, does bear mentioning when discussing Secondary controls. Temperature problems with Secondary systems can sometimes be traced to compressor operation. In these situations, the Compressor Low Pressure Switch should be checked.

Chiller Controls

Two devices on the chiller should be checked on a regular basis:

- Freeze-stat
- Probes

Proper functioning of these devices is necessary for the chiller to operate. Problems with either could result in a loss of coolant temperature or a malfunctioning or failure of the chiller.

Case and Walk-In Coil Checks

Secondary system coils should be checked the same as in DX systems with the exception of one important difference. Secondary coils must not be isolated on both ends (supply and return) for any significant amount of time. As the coolant temperature rises, the hydraulic pressure can build to the point of causing coil or pipe failure.

Visual Inspection

In addition to the safety checks to be performed on the system, it also necessary to further examine its operation for any other problems that might occur. Some of the checks listed below should be performed regularly and other less frequently but at consistent intervals.

The areas of the system on which inspections should be focused are the:

- Electrical and mechanical components of the system
- Case coils
- Condensers
- Inspect DX system for leaks
- Check grease fittings for proper lubrication

Apart from the items already mentioned, the majority of the inspections necessary for Secondary systems are exactly the same as those for DX systems. The inspections that are described in the following section should be performed on the DX side of the system anytime the Secondary side is inspected.

Regular Inspections

Typical of the checks that should be routinely performed on DX systems are the following steps:

1. Check compressor discharge and suction pressures—if not within system design limits, determine why and take corrective action
2. Check liquid line sight glass and expansion valve operation—if there are indications that more refrigerant is required leak test all connections and system components and repair any leaks before adding refrigerant
3. Using suitable instruments carefully check line voltage and amperage at the compressor terminals; voltage must be within 10% of that indicated on the condensing unit nameplate—if high or low voltage is indicated, notify the power company; If amperage draw is excessive, immediately determine the cause and take corrective action (on 3 phase motor compressors, check to see that a balanced load is drawn by each phase)

4. Check head pressure controls for pressure settings
5. Re-check all safety & operating controls for proper operation and adjust if necessary

Other Checks

All electrical connections (including those at the compressor terminals) should be periodically checked for tightness. Loose connections contribute to low voltage conditions that may cause motor failure.

Refrigerant connections should be inspected to ensure that they have not loosened. Whenever it is necessary to add refrigerant, a careful leak check of all refrigerant connections should be made.

The oil level in the compressor crankcase should be at the specified level in the sight glass at all times. If the oil level is low, more oil should not be added until the cause of the oil migration is corrected. Check the expansion valve adjustment, the size of the risers and traps and the head pressure control valve settings.

Dirty, discolored oil may indicate one of two things:

- Contaminants such as moisture, air, etc., trapped in the system. If the discoloration is not severe, a new liquid line filter-drier and 1 or 2 oil filters are usually enough to remove contamination and clean the oil. If the discoloration is severe and caused by contamination alone, the oil should be replaced and a new liquid line filter-drier and oil filter installed as many times as necessary to eliminate the contamination.
- Excessive system pressure drop or improper control settings. Compressors that operate in a vacuum result in oil discoloration due to motor overheating. The resulting inadequate suction cooling causes overheating of the motors.

Preventive Maintenance

Preventive maintenance, as the term suggests, is intended to stop problems before they happen. Preventive maintenance when performed at the intervals specified below reduces problems and keeps the system running smoothly.

Preventive maintenance should, in particular, be performed on unit coolers, air-cooled condensers and fluid coolers.

Cases and Unit Coolers

At every six month interval, or sooner if local conditions cause clogging or fouling of air passages through the finned surface, the following items should be checked:

1. Visually inspect unit

- a. Look for signs of corrosion on fins, cabinet, copper tubing and solder joints.
- b. Look for excessive or unusual vibration for fan blades or sheet metal panels when in operation. Identify fan cell(s) causing vibration and carefully check motor and blade.
- c. Look for oil stains on headers, return bends, and coil fins. Check any suspect areas with an electronic leak detector.
- d. Check drain pan to insure that drain is clear of debris, obstructions or ice buildup, and is free draining.

2. Clean evaporator coil and blades

- a. Periodic cleaning can be accomplished by using a brush, pressurized water or a commercially available evaporator coil cleaner or mild detergent. Never use an acid based cleaner. Follow label directions for appropriate use. Be sure the product you use is approved for use in your particular application.
- b. Flush and rinse coil until no residue remains.
- c. Pay close attention to drain pan, drain line and trap.

3. Check the operation of all fans and ensure airflow is unobstructed

- a. Check that each fan rotates freely and quietly. Replace any fan motor that does not rotate smoothly or makes an unusual noise.
- b. Check all fan set screws and tighten if needed.
- c. Check all fan blades for signs of stress or wear. Replace any blades that are worn, cracked or bent.
- d. Verify that all fan motors are securely fastened to the motor rail.

e. Lubricate motors if applicable.

4. Inspect electrical wiring and components

- a. Visually inspect all wiring for wear, kinks, bare areas and discoloration. Replace any wiring found to be damaged.
- b. Verify that all electrical and ground connections are secure, tighten if necessary.
- c. Check operation/calibration of all fan cycle and defrost controls when used.
- d. Look for abnormal accumulation of ice patterns and adjust defrost cycles accordingly.
- e. Compare actual defrost heater amp draw against unit data plate.
- f. Visually inspect heaters to ensure even surface contact with the coil. If heaters have crept, decrease defrost termination temperature and be sure you have even coil frost patterns. Re-align heaters as needed.
- g. Check drain line heat tape for proper operation (supplied and installed by others).

5. Refrigeration Cycle

- a. Check unit cooler superheat and compare reading for your specific application.
- b. Visually inspect coil for even distribution.

Fixture Cleaning

The evaporator coils in most refrigeration cases are by design located at the bottom of the case. This arrangement keeps the piping, valves and fans needed to operate the cases out of sight and places the product closer to the customer. From a merchandising perspective, this approach makes for sound design. From a maintenance perspective, however, it's somewhat problematic.

Refrigeration case evaporator coils because of their placement are subject to fouling from product and packaging debris that settles to the bottom of the case. Dust and other airborne material that settles on the coils between defrost cycles may also accumulate. This material must be removed and the cases kept clean in order for the coils to operate efficiently.

Cleaning Procedures

A periodic cleaning schedule should be established to maintain proper sanitation, insure maximum operating efficiency, and avoid the corrosive action of food fluids on metal parts that are left on for long periods of time. Hillphoenix recommends cleaning once a week by performing the following procedures:

1. To avoid shock hazard, be sure all electrical power to the case (or other type of refrigeration unit) is turned off before cleaning. In some installations, more than one disconnect switch may have to be turned off to completely de-energize the case.
2. Check the waste outlet to insure that it is not clogged before starting to clean and avoid introducing water faster than the case drip pipe can carry it away.
3. Avoid spraying cleaning solutions directly on fans or electrical connections.
4. Place a temporary separator between the cases being cleaned and ones adjacent to it.
5. Keep cases turned off long enough to clean any frost or ice from coil and flue areas.
6. Remove and clean the honeycomb discharge grill. It may be necessary to use spray detergent and a soft, long bristle brush.
7. Use mild detergent and warm water to clean with. When necessary, water and baking soda solution will help remove case odors. Avoid abrasive scouring powders or pads.
8. Use the following specialty cleaning products for difficult stains that may appear on polymer exterior bumper parts:

3M brand© Stainless Steel Cleaner and Polish

- 3M brand© Troubleshooter Cleaner
- 3M brand© Sharpshooter, Extra Strength No Rinse Cleaner

Revere© aluminum powder for tank liner

- Armor All© for polymer parts

Troubleshooting Procedures

Supermarket refrigeration systems are complex configurations of equipment. Like any other types of complex machinery, regardless of the care and attention given to their installation and startup, refrigeration systems will occasionally run into problems. In most cases the safety and operating controls with which the system is equipped will give some indication of the problem. In other cases, however, the causes will not be so clear. For those situations, various troubleshooting procedures have been developed so that the causes of problems in the system can be identified and the appropriate actions taken to get the system up and running.

Sometimes when problems occur they can be determined rather quickly to involve a certain part of the system. At other times, it may be necessary to check the entire system in order to isolate the cause of a problem. The following charts provide guidelines for both general and specific indications of trouble in the system.

In general, two types of problems may occur in Secondary systems; either the coolant supply or the discharge air is not the right temperature. A third problem on Secondary systems has to do with the pump seals.

Incorrect Coolant Supply Temperature

If the coolant supply temperature is not correct, check:

- The solution concentration
- The chiller approach
- Compressor operating mode
- Thermostatic Expansion Valve (TXV)
- Defrost system

Solution Concentration

Check the solution concentration of the Secondary coolant and verify that the freeze point is correct. Adjust if necessary by adding undiluted coolant.

Chiller Approach

Check the chiller approach temperature and verify that it is within the range of 5 to 10°F.

Compressor Operating Mode

Verify that the compressor(s) is properly operating (loading and unloading) and that the controller is set to maintain the required suction pressure.

Thermostatic Expansion Valve (TXV)

Check that the TXV is operating properly and that the superheat setting is correct. Check for flashing in the liquid line in front of the valve.

Defrost System

Check to make sure that defrost system is functioning properly and not interfering with normal refrigeration.

If all of these appear to function properly, one further check is to shut off the chiller for a sustained period (about 30 minutes) and let it warm up before turning back on. Any ice that may have built up during normal operation will melt and the unit should return to proper functioning.

Incorrect Case Temperature

If the coolant supply temperature is correct, but the case temperature is not:

- Perform regular DX case troubleshooting
- Check flow rate through the case
- Check for air in the coil and/or trapped air in lines feeding case
- Check the pump strategy (operation) for proper on/off cycling

Regular Case Troubleshooting Procedures

The following steps (beginning on the next page) lay out a set of troubleshooting procedures for regular DX coils, and with little alteration they should be performed on Secondary systems.

If, after performing the steps described, problems persist and you are not able to determine their cause, you may need to contact Hillphoenix Field Service for assistance.

Secondary Installation, Startup, Maintenance and Troubleshooting

HillPhoenix Learning Center

Lesson 4 - Secondary Maintenance and Troubleshooting

Evaporator Troubleshooting		
PROBLEM	POSSIBLE CAUSES	POSSIBLE CORRECTIVE STEPS
Fan(s) will not operate.	1. Main switch open.	Close switch.
	2. Blown fuses.	Replace fuses.
		Check for short circuits or overload conditions.
	3. Defective motor.	Replace motor.
	4. Defective timer or defrost thermostat.	Replace defective component.
	5. Unit in defrost cycle.	Wait for completion of cycle.
6. Coil does not get cold enough to reset thermostat.	Adjust fan delay setting of thermostat.	
Room temperature too high.	1. Room thermostat set too high.	Adjust thermostat.
	2. Superheat too high.	Adjust thermal expansion valve.
	3. System low on refrigerant.	Add refrigerant.
	4. Coil iced-up.	Manually defrost coil.
		Check defrost controls for malfunction.
	5. Unit cooler located too close to doors.	Relocate unit cooler or add strip curtain to door opening.
6. Heavy air infiltration.	Seal unwanted openings in room.	
Ice accumulating on ceiling around evaporator and/or on fan guards, venturi or blades.	1. Defrost duration is too long.	Adjust defrost termination thermostat.
	2. Fan delay not delaying fans after defrost period.	Defective defrost thermostat or not adjusted properly.
	3. Defective defrost thermostat or timer.	Replace defective component.
	4. Too many defrosts.	Reduce number of defrosts.

Evaporator Troubleshooting		
PROBLEM	POSSIBLE CAUSES	POSSIBLE CORRECTIVE STEPS
Coil not clearing of frost during defrost cycle.	1. Coil temperature not getting above freezing point during defrost.	Check heater operation.
	2. Not enough defrost cycles per day.	Adjust timer for more defrost cycles.
	3. Defrost cycle too short.	Adjust defrost thermostat or timer for longer cycle.
	4. Defective timer or defrost thermostat.	Replace defective component.
Ice accumulating in the drain pan.	1. Defective heater.	Replace heater.
	2. Unit not pitched properly.	Check and adjust if necessary.
	3. Drain line plugged.	Clean drain line.
	4. Defective drain line heater.	Replace heater.
	5. Defective timer or thermostat.	Replace defective component.
Uneven coil frosting.	1. Defective heater.	Replace heater.
	2. Located too close to door or opening.	Relocate evaporator.
	3. Defrost termination set too low.	Adjust defrost termination setting higher.
	4. Incorrect or missing distributor nozzle.	Add or replace nozzle with appropriately sized orifice for conditions.

Final Checks

A few final areas to look at when problems occur are:

- Fan motors
- Fan delays and Defrost Termination Controls
- Defrost heaters
- Drain Pans

Fan Motor

If the motor does not operate, or it cycles on thermal overload, remove the motor leads from terminal block and apply the correct voltage across the leads. If the motor still does not operate satisfactorily, it must be replaced. Before starting the unit, rotate the fan blades to make sure they turn freely and have sufficient clearance.

Fan Delay & Defrost Termination Control

These controls generally use a single pole double throw switch. Usually the red lead wire is wired to common. The black wire then is wired in series with the fan motors. A brown wire is often wired in series with the defrost termination solenoid in the timer. In controls wired this way, the brown and red contacts close and the black and red contacts open when the temperature is above the On set-point (e.g., 55°F). The black and red contacts close and the brown and red contacts open when the temperature is below the Off set-point (e.g., 35°F).

On the initial call for refrigeration, or pull-down, the fan will not start until the coil temperature reaches approximately 35°F (in this example). If the case is still comparatively warm (e.g., 60°F) when the fan starts, then blowing this warm air over the coil may cause it to warm up to 55°F and thus stop the fan. Therefore, the fan may recycle on initial pull down. This control cannot be adjusted.

If the fan motor fails to start when the control is below the set-point, disconnect the fan motor leads and check the motor as described above for fan motors. Also check whether current is being supplied at “N” and “4” from the timer. The fan delay control must be below 35°F when checking for a closed circuit.

Defrost Heater

If a defrost heater unit shows little or no defrosting, and does not heat, disconnect the heater and check to see if it is burned out. To test, apply correct voltage across heater or use a continuity flashlight battery tester.

Drain Pan

If a drain pan has an ice build-up, the drain line may be frozen. The drain line should be pitched sharply and exit cabinet as quickly as possible. Sometimes the location and the ambient air at the drain outside of the case

may cause the drain pan to freeze-up. A drain line heater may be required to correct the freeze-up. Any traps in the drain line must be located in a warm ambient location.

Finally, after correcting a faulty condition it is essential that the coil and case be free of ice before placing the case back on automatic operation.

Wrap Up

In this lesson, the safety and operating controls were explained. The visual inspections and the schedules on which they should be performed were discussed. Cleaning and regular maintenance procedures were also laid out step-by-step. Finally, specific troubleshooting procedures were presented that enable problems to be identified and actions taken to remedy them.

Besides acquainting you with the procedures listed in the lesson, the value of this information definitely extends beyond the class. While it may not be practical to take this Participants Manual with you when visiting job sites, Xeroxed copies of the pages could help in recalling what to do in a given situation.

If you have any questions about the steps or procedures listed here, be sure to discuss them with your instructor before leaving the class.

Secondary Installation, Startup, Maintenance and Troubleshooting

HillPhoenix Learning Center

Lesson 4 - Secondary Maintenance and Troubleshooting
