

TABLE OF CONTENTS

Table of Contents	1
Photograph and Ice Making Capacity	2
Specifications and Dimensions	3-4
Selecting Location:	
Uncrating	5
Location	6
Preparation for Installation	6
Installation – Water Drain	7
Wiring Diagrams:	
Air Cooled	8
Water Cooled	9
Diagram Installation Practice	10
Final Check List	11
Start-Up	12-13
Cycle of Operation:	
Harvest Cycle	13-14
Freezing Cycle	15-16
Service Analysis Charts	17-18
Exploded Views – Component Parts:	
Sump Pump	19
Control Box	20
Complete Unit (Top View W.C.)	21
Complete Unit (End View)	22
Complete Unit (Top View A.C.)	23
Case Parts	24
Compressor Assembly – Air and Water	25
Water Valve	26
Freezer Assembly	27-28
Drive Linkage and Spray Bar	29
Functional Parts and Maintenance	30
Service Complete Unit	31
Maintenance Instructions	32

All specifications within this manual are subject to change without notice.

**THIS PAGE
INTENTIONALLY
LEFT BLANK**

SCOTSMAN® SUPER CUBER SM-205 SERIES

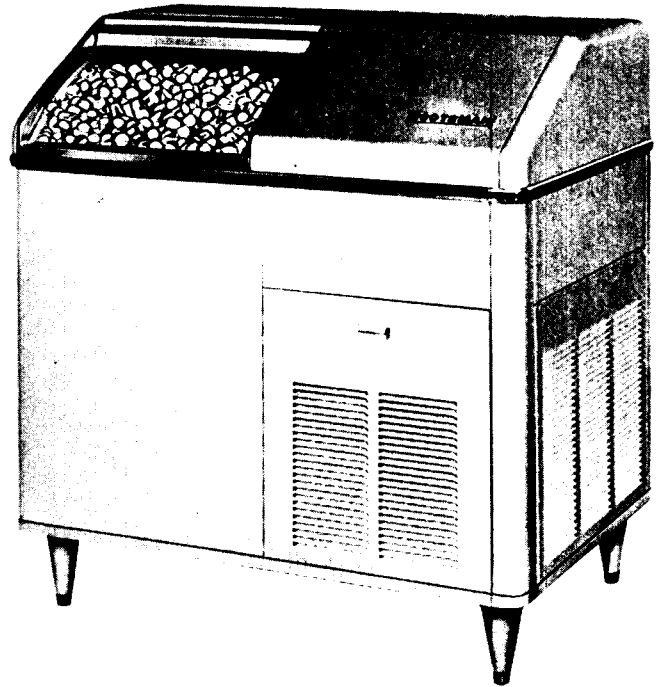

ICE MAKING CAPACITY:

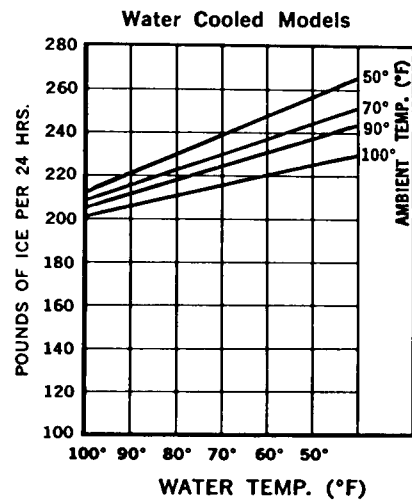
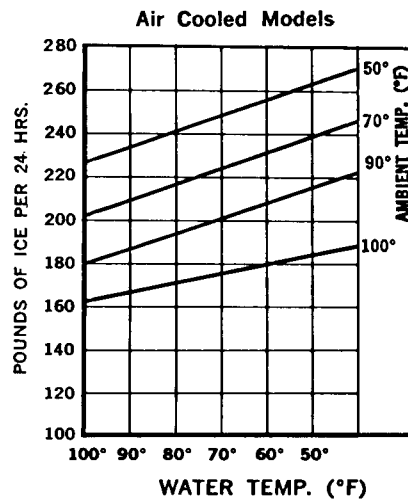

SPECIFICATIONS

SUPER CUBER SM-205 SERIES	MODEL SM-205J	MODEL SM-205WJ	MODEL SM-205J-SS	MODEL SM-205WJ-SS
CONDENSER, Air Cooled	X		X	
CONDENSER, Water Cooled		X		X
COMPRESSOR 3/4 HP	X	X	X	X
FINISH, Hammerloid Grey	X	X		
FINISH, Stainless Steel			X	X
SHIPPING WEIGHT	380	380	385	385

STANDARD ELECTRICALS	MINIMUM WIRE SIZE	TOTAL AMPERAGE
115/60/1	2 wire 12 gauge	16.9 Amperes

CAPACITY: Refer to Production Chart
 STORAGE BIN: (self-contained) 150 lbs.
 Stainless Steel Lined

DEPTH: 24-1/2"
 WIDTH: 44-1/4"
 HEIGHT: (with legs) 45-1/4" to 46"
 HEIGHT: (without legs) 39-1/4"

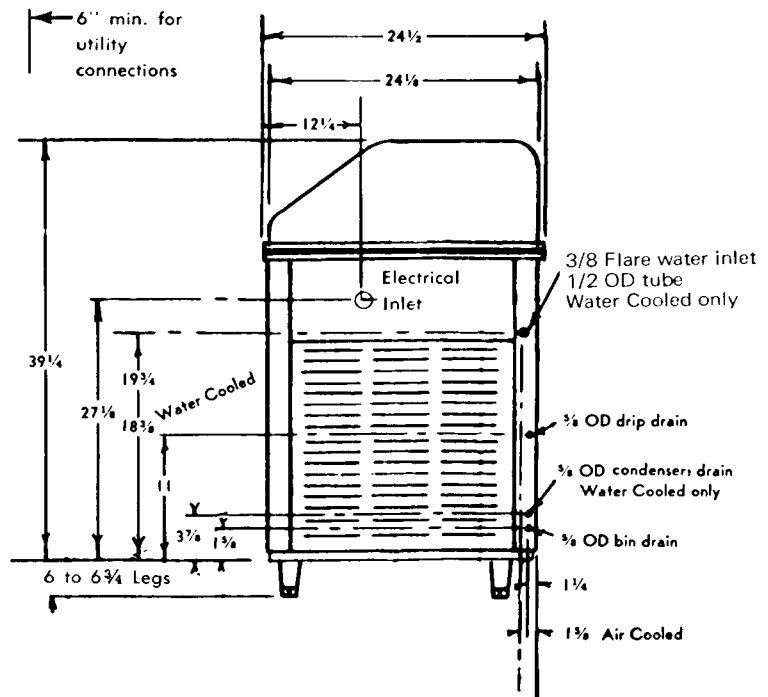
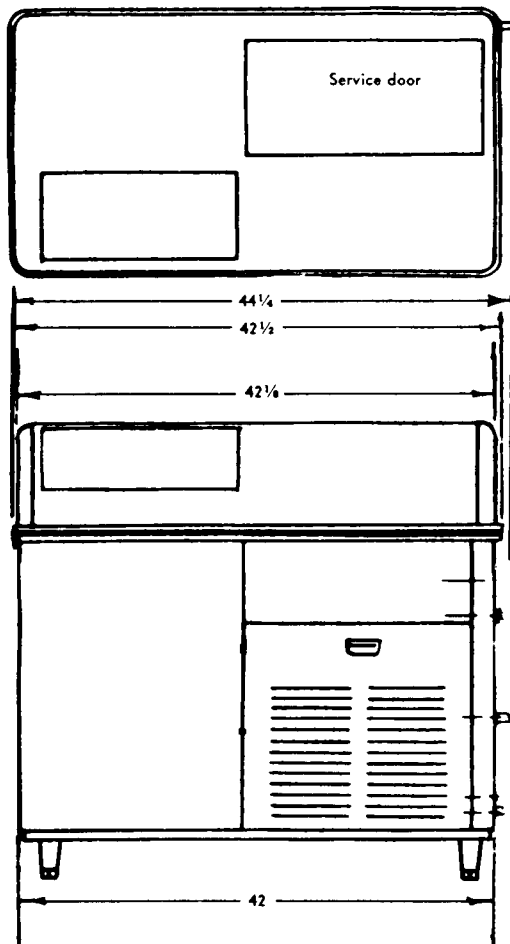

SPECIFICATIONS

	Air Cooled	Water Cooled
Water Pressure (minimum)	20 pounds	Same
Refrigerant Control	Capillary Tube	Same
Compressor 3/4 H.P.	Copelaweld 115/60/1	Same
Condenser	Air Cooled	Water Cooled
Refrigerant	Refrigerant 12	Same
Refrigerant Charge	20 ounces	20 ounces
Power Consumption	17.25 Amperes	17 Amperes
Cubes per Harvest	102 Compact Cubes	Same
Water Consumption to Produce Ice	2 Gal. per hour	Same
Dimensions		
Height - with 6" legs	45-1/4"	45-1/4"
Height - less 6" legs	39-1/4"	39-1/4"
Width	44-1/4"	44-1/4"
Depth	24-1/2"	24-1/2"
Weights		
Uncrated	385 lbs.	385 lbs.
Crated	405 lbs.	405 lbs.

INSTALLATION

UNCRATING OF MACHINE

1. The complete machine comes in one crate. After the crate is removed, inspect for concealed damage. Remove the bottom skid by removing all bolts. Then cut all wires holding support packing from refrigerant line. Be sure the compressor is snug on mounts. Then check all refrigerant lines for rubbing or touching other surfaces. Also check for possible transportation damage.
2. Remove all service doors and panels.
3. Remove leg package in compartment base and install 4 legs in unit base sockets.
4. Remove protective shipping tape from bin door, freezer curtain.
5. Remove water strainer from storage package for installation in water supply line feeding unit.
6. Open electrical control box and prepare for hook up, use knock outs, cord connectors, etc. Then check unit name plate voltage against building source voltage and make sure they correspond. Caution — improper voltage supplied to units will void your warranty protection.
7. Make sure suction service valve on the condensing unit is fully back seated. Replace the valve cap after checking. All models are shipped with valve back seated.
8. Make sure that the flow of air is not impeded in any way over condenser on air-cooled models. Keep condenser clean. (Check and clean the condenser monthly.)
9. Operating room temperatures are minimum 50° F. and maximum 100° F.
10. Remove Warranty card and Users Manual from storage bin and wipe bin clean with damp cloth.
11. Fill out warranty card completely including model and serial numbers as taken from aluminum plate found behind front service panel and forward to Scotsman factory using self mailing card.
12. Level unit with adjustable legs, call authorized Scotsman distributor or dealer for proper installation, start up and check.

LOCATION OF THE ICE CUBE MACHINE

UNDER BAR INSTALLATIONS – Locate, if possible, so left end panel is accessible. Locate unit so proper circulation can be attained around the unit and behind it at least four inches. Provide plumbing and electrical connections so the unit can be moved out where the entire top hood can be removed and the unit can still be operated.

KITCHEN INSTALLATION – As a rule, the kitchen is not the most practical place to install an air-cooled condensing unit, as grease is almost always present and makes cleaning of the condensing unit difficult. Do not locate near range or steam table or other heating devices that may be used in the kitchen.

STOREROOM INSTALLATIONS – Be sure storeroom is of adequate size and properly ventilated. A small, poorly ventilated room will greatly impair the efficiency of the unit. The Storeroom must be kept above 50 degrees in the winter months.

BASEMENT INSTALLATIONS – Locate machine in the coolest place. Locate the machine in a dry place. Keep away from furnace and boiler room. Keep away from service chutes and runways, also coal or other dust of any kind. If the machine is set over a floor drain, block the machine up enough to eliminate any possible damage to the machine.

LOCATE THE MACHINE SO THAT IT CAN BE SERVICED WHEN NECESSARY. ALLOW AT LEAST FOUR INCHES OF SPACE AROUND THE MACHINE FOR CIRCULATING AIR.

IMPORTANT: ADJUST LEVELER LEGS. MACHINE MUST BE LEVEL.

ELECTRICAL CONNECTIONS AND CHARACTERISTICS

115 volts, 60 cycle, single phase	Air Cooled	Water-cooled
Compressor	14.0 Amperes	14.0 Amperes
Sump Motor	1.32 Amperes	1.32 Amperes
Fan-Air Cooled Models.	.75 Amperes	None
Spray Bar Motor	.6 Amperes	.6 Amperes
TOTAL – FULL LOAD AMPERES	16.67 Amperes	15.92 Amperes

This unit should be wired to a 20 Amp. circuit. Be certain that the Super Cubers are on their own circuit and individually fused. The maximum allowable voltage variation should not exceed 10 per cent of the nameplate rating even under starting conditions. Low voltage can cause erratic operation, and may be responsible for serious damage to the overload switches and motor windings.

All external wiring should conform with National State and local code requirements. Check the voltage on the line before connecting the machine.

ELECTRICAL CONNECTIONS

12 Gauge wire will be adequate for short runs. For runs exceeding 50 feet, go to next heavier gauge. NOTE: All Scotsman cubers require a neutral wire and a solid earth ground wire.

WATER SUPPLY AND DRAIN CONNECTIONS

WATER SUPPLY – Air Cooled Models

The recommended water supply line is 3/8" OD copper tubing for air-cooled units. Connect to a cold water supply line with regular plumbing fittings with a shut-off valve installed in an accessible place between supply line and machine. The water strainer supplied with the unit should be mounted with clean-out plug down. Locate the strainer next to the machine and the arrow in the direction of the flow.

A 3/8" male flare fitting is provided on right rear corner for convenience in hook up.

WATER SUPPLY – Water Cooled Models

Water cooled models have same inlet water supply as the air cooled models. An additional 5/8" condenser water drain is added, however.

When choosing the water supply for this cuber, consideration should be given to:

- A. Length of run.
- B. Water clarity and purity.
- C. Adequate supply pressures.

Since water is the most important single ingredient in producing ice, you cannot over emphasize the three items mentioned above. Low water pressure (below 20 pounds) may cause malfunction of the three way water valve. Water containing excessive minerals will tend to produce cloudy colored cubes and scale build up on parts in the water system.

Heavily chlorinated water can be controlled using charcoal or carbon filters.

WIRING DIAGRAM Air Cooled

115/60/1

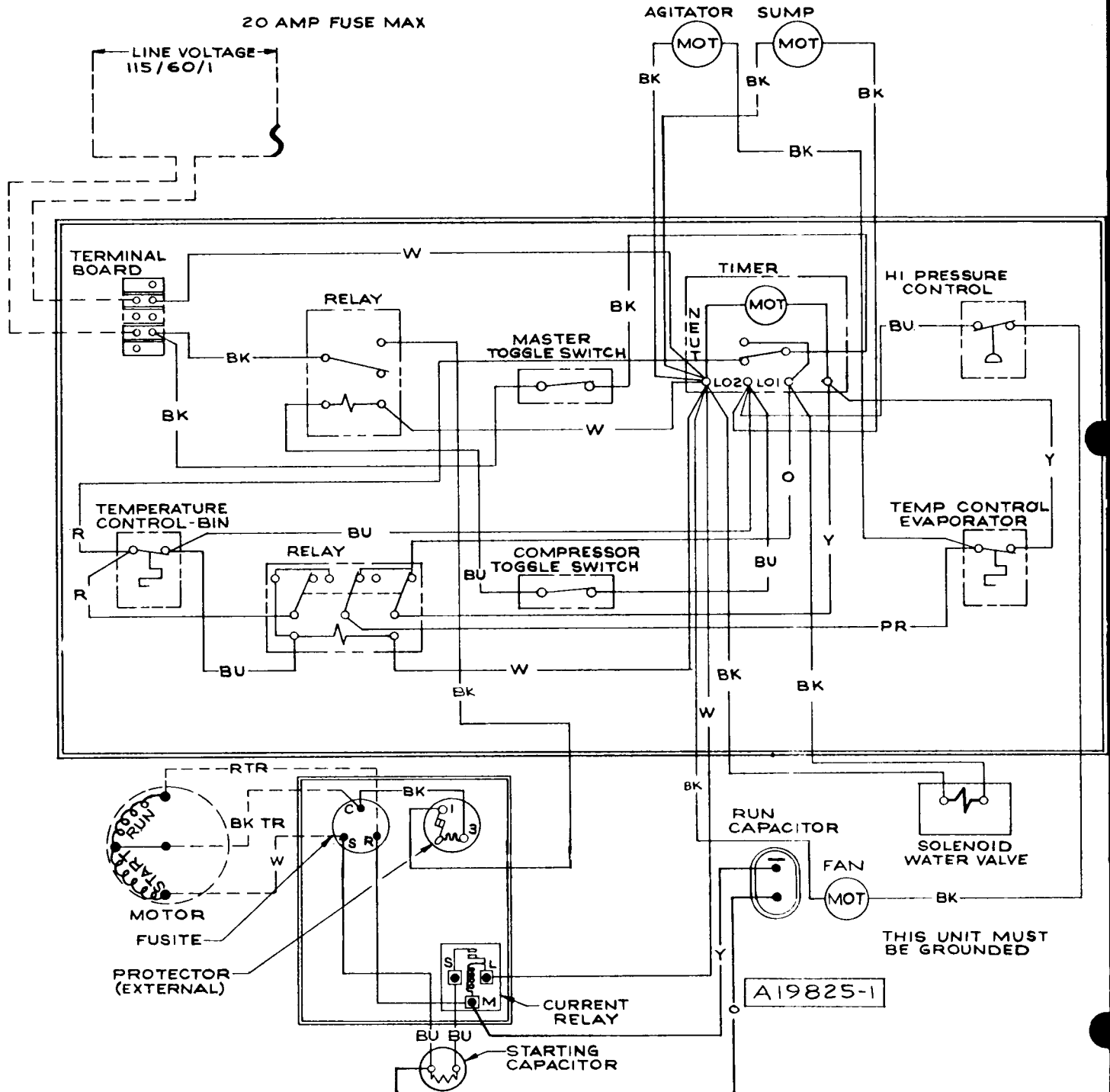

WIRING DIAGRAM
Water Cooled

115/60/1

20 AMP FUSE MAX

LINE VOLTAGE
115/60/1

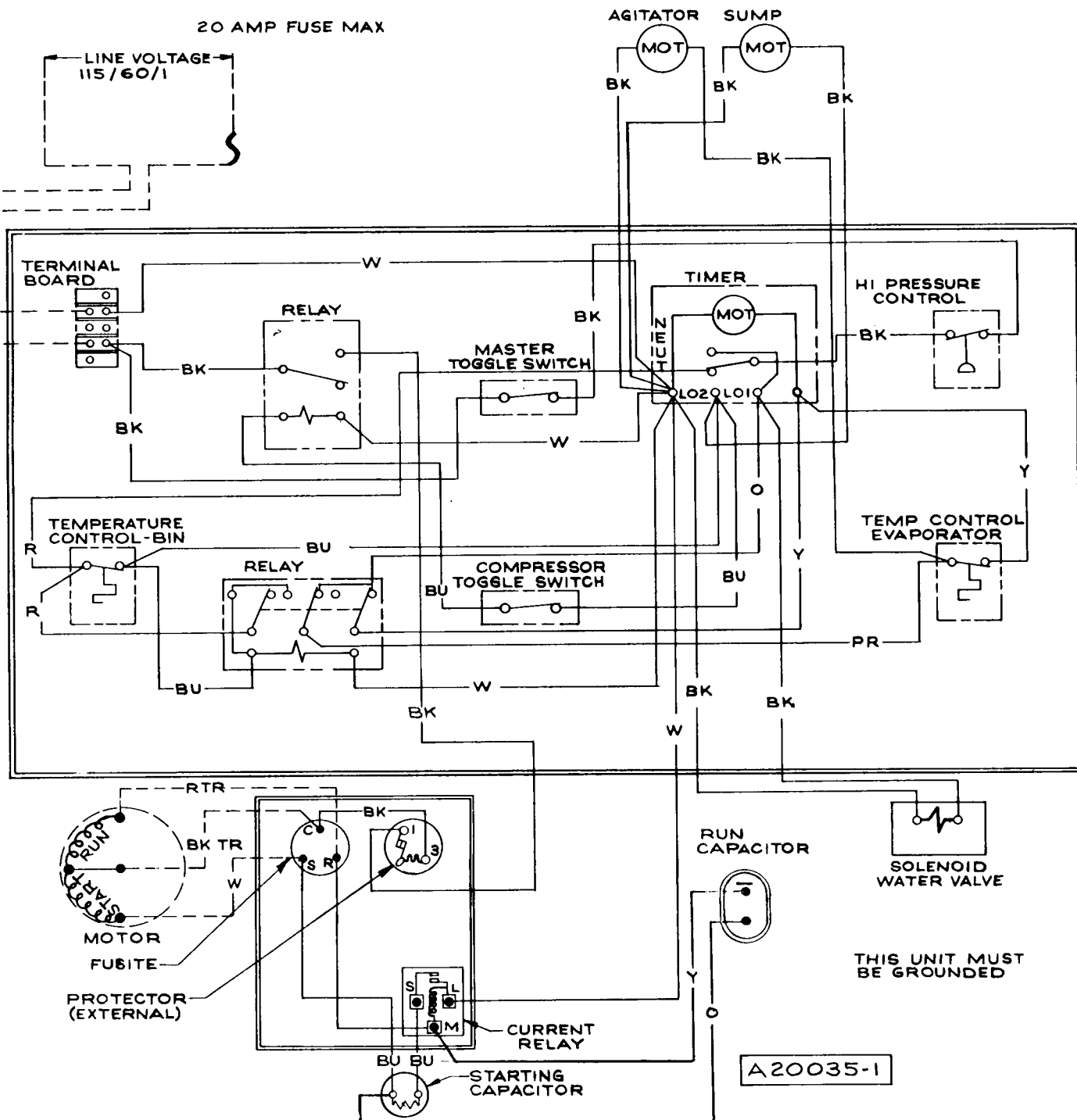

INSTALLATION PRACTICE

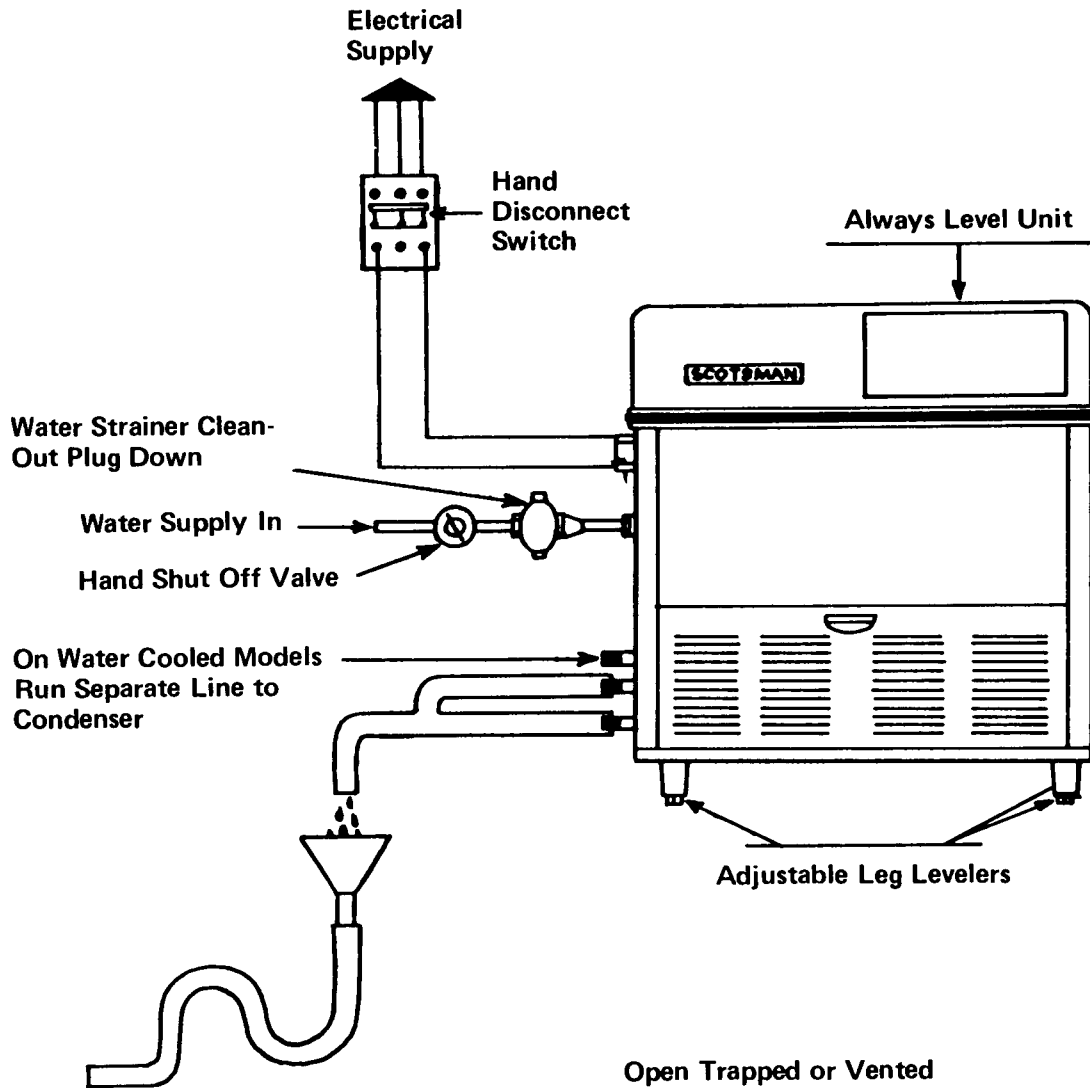

Open Trapped or Vented
Drain. Recommended 1/4 inch Fall
Per foot of run on drain lines.

FINAL CHECK LIST

1. Is the unit level? (IMPORTANT)
2. Have all electrical and piping connections been made?
3. Has the voltage been tested and checked against the nameplate rating?
4. Have the compressor hold-down bolts been checked to insure the compressor is snug to its mounting pads?
5. Is the water supply valve open and the electric power properly hooked up?
6. All masking tape removed from doors, panels and inner freezer curtain?
7. Is the unit clean? Has storage ben been wiped clean with cold water cloth?
8. Has the owner been given the operating manual, and has he been instructed on how to operate the machine?
9. Have the installation and warranty cards been filled out? Check for correct model and serial numbers from serial plate on unit then promptly mail card to factory.
10. Check all refrigerant and conduit lines to guard against vibrations and possible failure.
11. Is there 4" clearance behind and around unit for proper air circulation?
12. Is unit in a room where ambient temperatures are minimum 50° F. even in winter months?
13. Has water supply pressure been checked to insure at least a minimum pressure of 20 pounds?

INSTALLATION – START UP

1. Remove hood (top) service panel and lower front, right side service doors to facilitate start up and check out.
2. Make sure water supply is turned on, then check timer finishing clock in main control box making sure the micro switch roller is resting down in offset slot in the cam (harvest position). If adjustment is necessary, turn timer knob clockwise into harvest position.
3. Inspect components in electrical control box, check for loose or frayed wire, then turn both manual switches to "on" position. All cubers have two manual on-off switches. One is for motor compressor only during cleaning operation, one is master switch for complete unit.
4. When both switches are thrown "on", water inlet solenoid will be energized allowing water to enter cuber, thru warm water tank, 3 way water valve and up into back side of freezer cup section. This will "fill" icemaker for the freezing cycle - Check operation of spray bar drive motor thru hood top panel. Spray bar motor should be running during harvest cycle.
5. Allow clock to carry unit through harvest cycle. This will be approximately three minutes. Dial pointer should be set on Number 3-1/2. After the compressor starts, turn the dial completely around and send it through another harvest cycle. Do this several times. This will completely flush out machine of any dust that may have accumulated in shipment.
6. After machine has been properly flushed, allow it to go into a freezing cycle - check for possible water leaks, check sump pump operation - should be running freely. Also note if jet tube operation is correct, and that none of the jets are plugged.
7. Time clock dial does not rotate at the end of the harvest cycle; it is started later by the cube size thermostat control located in the control box.
8. Freezing time will be approximately 20 minutes in a 70 degree ambient. (Longer if above, and shorter if below.) Average complete cycle time is 25 minutes.
9. Watch first cube harvest and check to make sure that plastic curtain sections have not been damaged in shipment. Also that curtains do not swing back into freezer and catch on spray bar.
10. Check size of cubes made: If too small, after a second cycle, adjust cube size control to lower or colder setting - until desired cube size is reached. Normal cube size is with a 1/4" depression in crown.
11. Check texture of cubes made: Partially cloudy cubes throughout suggest unit running short of water near end of freezing, or possibly an extremely bad water condition, which would indicate use of filtering or purifying equipment. Contact SCOTSMAN - Queen Products, Div., Ice Machine Service Department, Albert Lea, Minnesota, for further details.

INSTALLATION

12. With unit on harvest cycle, take a handful of cubes made and hold on storage bin thermostat cover. Should cut unit off at end of harvest cycle. Remove ice, unit should cut back on automatically in 3 or 4 minutes. Thermostat is factory set at 35 degrees out, 39 degrees in.
13. Install gauges and check head and back pressure: air-cooled models, head pressure after twenty minutes of freezing cycle at 70° ambient will be approximately 125 pounds PSI. The back pressure starts out at approximately 50 pounds PSI and gradually pulls down to approximately 4 pounds PSI just before harvest cycle. Higher ambients and dirty condenser will cause higher pressures. Water-cooled models have water regulating valves factory set at 135 pounds PSI: check reading and adjust if necessary. Back pressure will operate the same as on air-cooled models.
14. Remove gauges, replace control box cover and all service panels.
15. Instruct owner on how to operate and clean machine.

HARVEST CYCLE

At the end of the freezing cycle the time clock operated switch opens compressor, sump pump and fan motor circuit, and closes circuit to time clock motor, spray drive motor and solenoid operated inlet water valve. Inlet water pressure at bottom of hot water tank now forces heated water out the top of tank through warm water tubing and into back side of evaporator cup section. At the same time the surplus water from the preceding batch of ice cubes goes through three way water valve and off to drain. Water from the hot water tank flows into the rubber platen holding the evaporator cups and by conduction on back of cups causes the formed ice cubes to defrost or drop out. The platen-evaporator cavity is normally filled to the overflow level in 2 or 2-1/2 minutes. The amount of water running over the overflow pipe is controlled by the size of the flow control orifice and the length of the harvest time setting on the time clock past the overflow point. Over-flow water goes down the drain also.

Meanwhile, cubes released drop by gravity and are mechanically ejected thru curtained opening into ice storage bin by sprayer tube which is being actuated by drive motor. At the completion of harvest cycle, the micro-switch on the timer now drops points holding defrost components in cycle and switches to freezing cycle set of contacts. Timer completes harvest cycle when micro-switch roller lifts out of rear cam slot. Timer clock motor now stops and will not start again until cube size thermostat control closes once more. Electrically harvest cycle components cease, freezing cycle components start up. Chilled defrost water from the upper cavity now flows by gravity back through the three way water valve into freezer sump or reservoir pan. Here water is picked up by the water pump and continually recirculated through sprayer tube to produce the next batch of cubes.

HARVEST CYCLE – Water Circuit

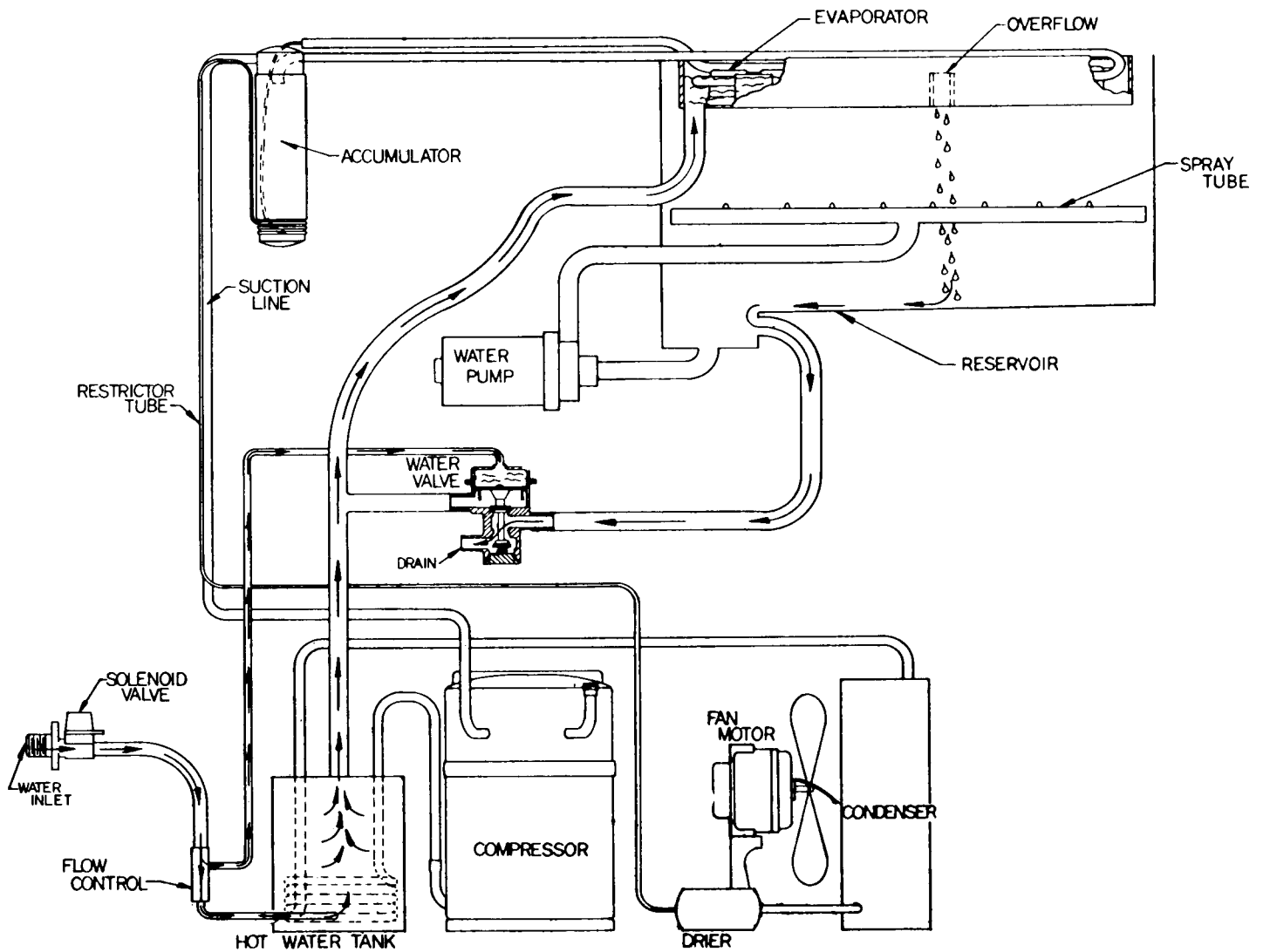

FREEZING CYCLE

As the freezing cycle starts, electrically the components operating are the compressor and fan motor, recirculating water pump and the sprayer tube drive motor.

The refrigerant circuit which equalized at about 50 pounds gauge during the "off" or harvest cycle, thru the capillary refrigerant control, now rises rapidly to 125 - 135 pounds head pressure. The suction or low side pressure starting at 50 pounds pulls down fairly quickly to about 25 pounds at which point the ice cubes are starting to form a thin shell in cube cups. Continuing from 25 pounds slowly on down towards the finished cube pressure of approximately 5 pounds takes an average of 20-25 minutes.

During this portion of the freezing cycle the electrical brain is the reverse acting, cube size thermostat. This thermostat electrically is holding the freezing cycle components "live". When the ice cubes are about 3/4 formed, the decreasing suction pressure and temperature, activate the temperature sensing bulb of the reverse acting, cube size control, closing its contacts. This does not interrupt the freezing cycle, the closing of the cube size thermostat contacts electrically transfers the finishing of the freezing cycle to the finishing clock motor or timer as it is sometimes called. One full revolution of the timer dial is 12 minutes as is noted by the numerals on the dial however of the total 12 minutes on the timer dial, 3 minutes are used for the defrost or harvest cycle.

This means then that after the cube size contacts close they activate the timer motor. This control takes over and continues freezing cycle for another 9 minutes with timer dial now turning. When the 9 minutes are completed, an offset in the timer dial allows a micro switch with activating arm riding on that cam to drop into the slot electrically stopping the freezing cycle and starting the 3 minutes harvest cycle - The clock motor continues thru harvest cycles. A notch on the timer dial now lifts micro switch arm up on dial, electrically stopping harvest cycle and starts back into a new freezing cycle.

FREEZING CYCLE Water & Refrigerant Circuit

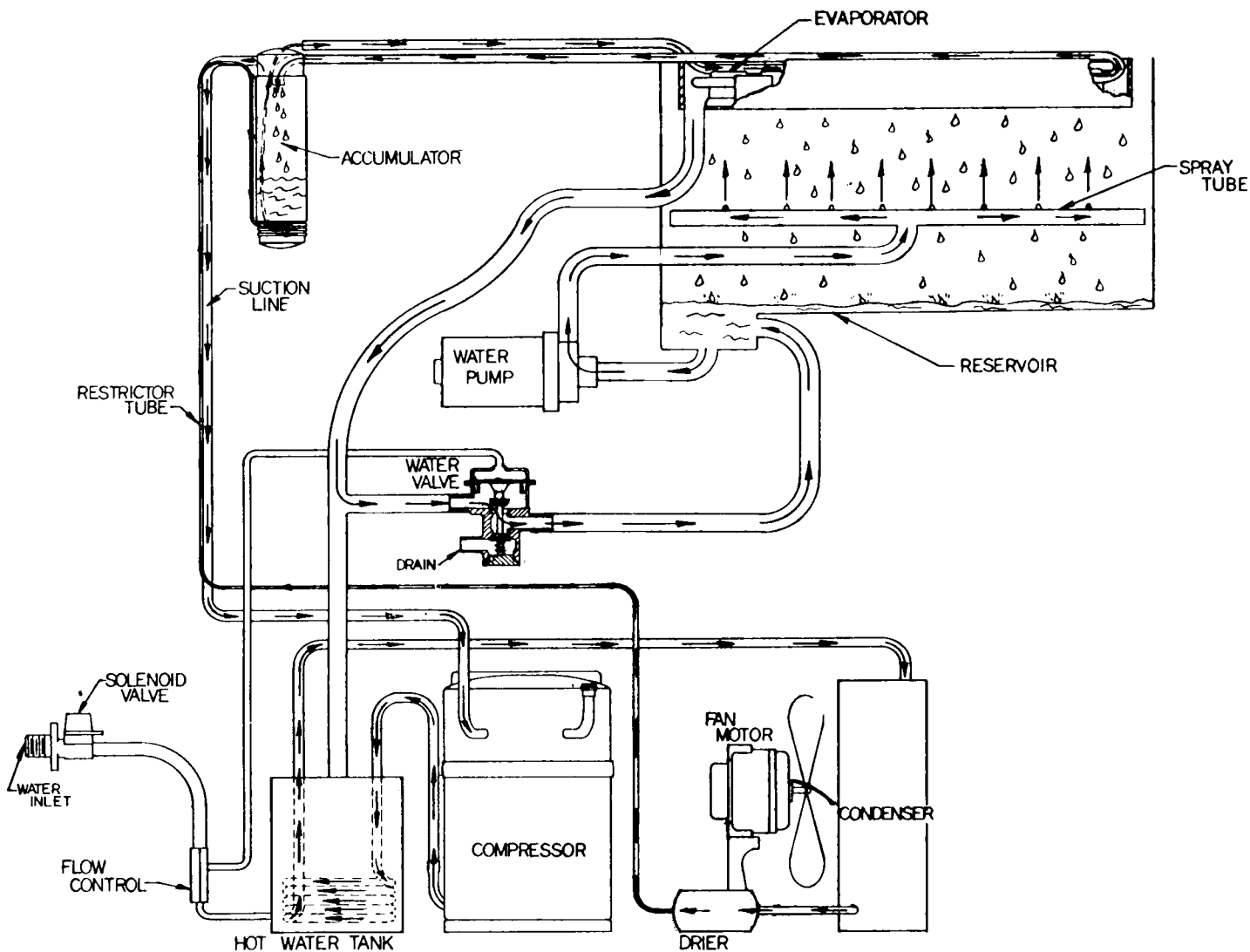

SERVICE ANALYSIS

SYMPTOM	POSSIBLE CAUSE	SUGGESTED CORRECTION
Irregular size cubes and some cloudy	<p>Some jets plugged</p> <p>Shortage of water</p> <p>Unit not level</p>	<p>Clean jets.</p> <p>See Shortage of Water.</p> <p>Water overflowing air vent holes on low side burning cubes. Level as required.</p>
Cubes too large	Cube size control turned too cold	Turn setting on cube size control dial towards warmer
Decreased ice capacity	<p>Inefficient compressor</p> <p>Leaky water valve</p> <p>High head pressure</p> <p>Non-condensable gas in the system;</p> <p>Poor Air circulation or excessively hot location</p> <p>Overcharge of refrigerant</p> <p>Partially restricted cap tube</p>	<p>Replace.</p> <p>Replace or repair.</p> <p>Dirty condenser. Clean. Bad fan motor. Replace.</p> <p>Purge the system.</p> <p>Relocate the unit, or provide for ventilation by cutting openings.</p> <p>Correct the charge. Purge off slowly.</p> <p>Purge & replace charge and drier</p>
Hole washed inside cube	Water over the top of the cube cups during harvest.	Level unit.
Poor harvests	<p>Too short defrost time</p> <p>Restriction in incoming water</p> <p>Insufficient quantity of hot water</p> <p>Solenoid valve not opening the water valve</p> <p>Air vent holes in upper cube cups plugged</p>	<p>Check and adjust harvest cycle. Timer should be set at 2-1/2.</p> <p>Check water feed line strainer and flow reducing valve. To give greater water flow increasing defrost time.</p> <p>Cold ambient - must be 50° minimum faulty fan control on air cooled models.</p> <p>Solenoid binding or burned out. Replace.</p> <p>Clean out holes.</p>

SYMPTOM	POSSIBLE CAUSE	SUGGESTED CORRECTION
Unit will not run.	<p>Blown fuse</p> <p>Bin thermostat set too high</p> <p>Switch in Off position</p> <p>Inoperative master switch</p> <p>Timer contacts open</p>	<p>Replace fuse & check for cause of blown fuse.</p> <p>Adjust thermostat. Set between 35° out to 39° in.</p> <p>Turn switch to On position.</p> <p>Replace switch</p> <p>Replace timer micro-switch</p>
Compressor cycles intermittently	<p>Low voltage</p> <p>Dirty condenser</p> <p>Air circulation blocked</p> <p>Inoperative condenser fan motor</p> <p>Non-condensable gases in system.</p>	<p>Check circuit for overloading. Check voltage at the supply to the building. If low, contact the power company.</p> <p>Clean with vacuum cleaner, air or stiff brush. (Do NOT use wire brush.)</p> <p>Allow sufficient air space all around unit.</p> <p>Check to see if defective. If defective, replace.</p> <p>Purge the system.</p>
Cubes too small	<p>Cube size control set too high</p> <p>Partially restricted capillary tube.</p> <p>Moisture in system</p> <p>Shortage of water</p> <p>Shortage of refrigerant</p>	<p>Lower the setting. Turn towards colder.</p> <p>Blow charge, add new gas & drier. After evacuating system with suction pump.</p> <p>Same as above.</p> <p>See remedies for shortage of water.</p> <p>Check for leaks and recharge.</p>
Cloudy cubes	<p>Shortage of water</p> <p>Dirty water supply</p> <p>Restricted drain on pump</p> <p>Accumulated impurities</p>	<p>See remedies for shortage of water. Use water softener or water filter. Clean pump strainer.</p> <p>Use SCOTSMAN Ice Machine Cleaner</p>
Shortage of water	<p>Water spraying out through curtains</p> <p>Three-Way water valve leaking</p> <p>Water entering hot water tank too slowly</p>	<p>Replace broken curtains if any broken.</p> <p>Check the valve for foreign matter. Check valve seats and replace if necessary.</p> <p>Check pressure at source - 20 lb. required. Dirt in solenoid and flow control - blow out. Partial restrictions in water strainer. Clean Strainer.</p>

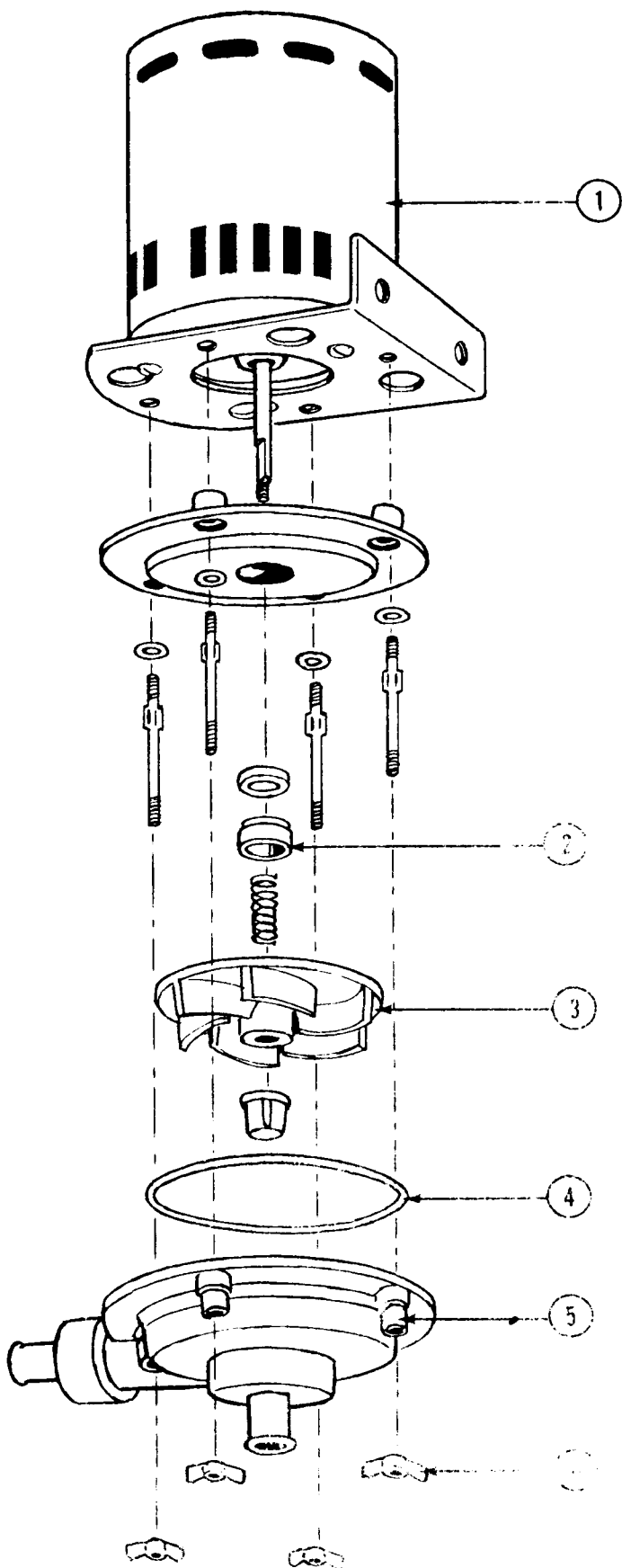

**SUMP PUMP ASSEMBLY
PART NO. 12-1532-1**

- | | | |
|----|------------|----------------|
| 1. | 12-1532-51 | Motor only |
| 2. | 12-1532-57 | Water Seal |
| 3. | 12-1532-58 | Impeller |
| 4. | 12-1532-60 | O-Ring |
| 5. | 12-1532-61 | Outlet Housing |
| 6. | 12-1532-62 | Wing Nuts |

REPLACING SEAL ON GPPS UNITS

1. Remove Wing nuts on housing, remove housing.
2. Remove impeller by holding impeller down and backing off impeller nut.
3. Remove the 4 No. 8-32 studs holding pump base to mounting plate.
4. Lift base off plate. Seal will slide off at same time.
5. Remove ceramic seal part and rubber cup from base plate.
6. Install new ceramic part and cup in base. Make sure cup does not "roll" and that ceramic is in firmly. Be careful not to scratch ceramic face.
7. Re-assemble base to mounting plate with the 4 studs, keeping motor shaft centered in ceramic.
8. Lightly lubricate "O" ring in carbon seal member. Use a nonpetroleum base lubricant. Do not use motor oil or 3 in one oil. This has deteriorating effect on the plastic.
9. Carefully slide carbon seal member down shaft until face contacts ceramic seat. Drop spring over shaft.
10. Engage tip of spring in slot on back of carbon. Hold motor shaft stationery and rotate spring and carbon member until top spring tip is directly on opposite side of shaft from flat.
11. Put impeller on shaft. Spring tip should engage slot in bottom of impeller to provide drive for seal.
12. Hold impeller flat against base plate. Screw on impeller nut until tips on bottom of nut touch tips of impeller hub. Back off slightly until impeller snaps up, the tips of impeller locating between the tips of the nut. This prevents impeller from backing off shaft, and automatically provides clearance between impeller and base plate.
13. Replace pump housing, making sure "O" ring is in position on base plate.
14. Replace 4 Wing nuts.

CONTROL BOX
115/60/1

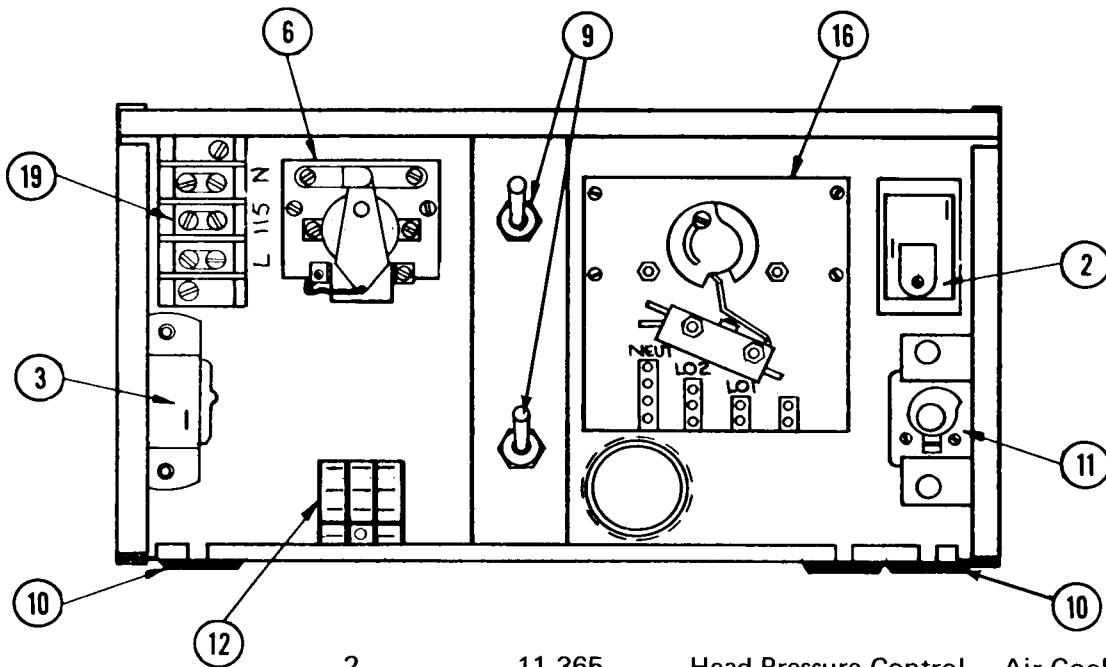
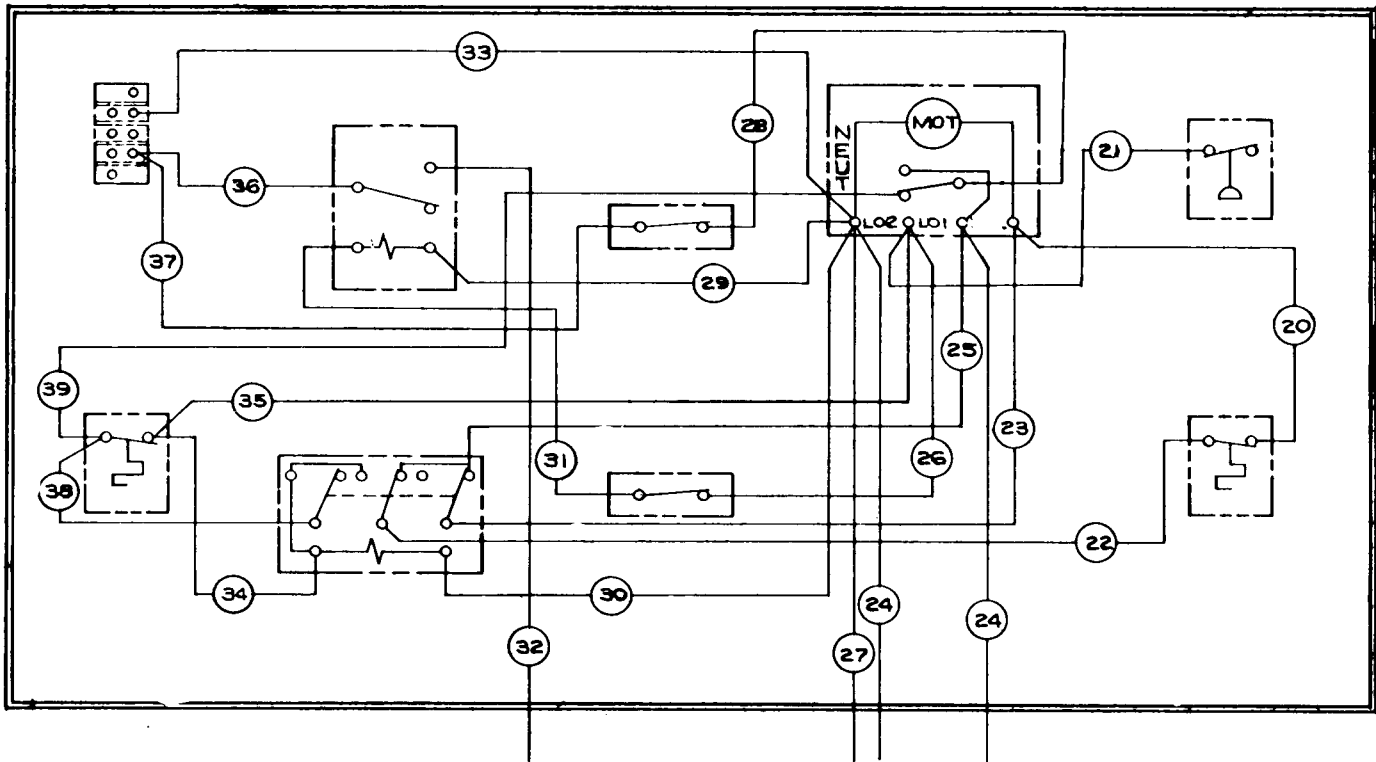

- | | | |
|-----|-----------|---|
| 2. | 11-365 | Head Pressure Control – Air Cooled Only |
| 2. | 11-357 | Head Pressure Control – Water Cooled Only |
| 3. | 11-353 | Bin Thermostat |
| 6. | 12-419 | Relay |
| 9. | 12-426-1 | Switches |
| 10. | 13-124 | Grommet |
| 11. | 11-345 | Cube Size Thermostat |
| 12. | 12-1598 | Complete Cycle Relay |
| 16. | A-21038-1 | Timer |
| 19. | 12-813 | Terminal Block |

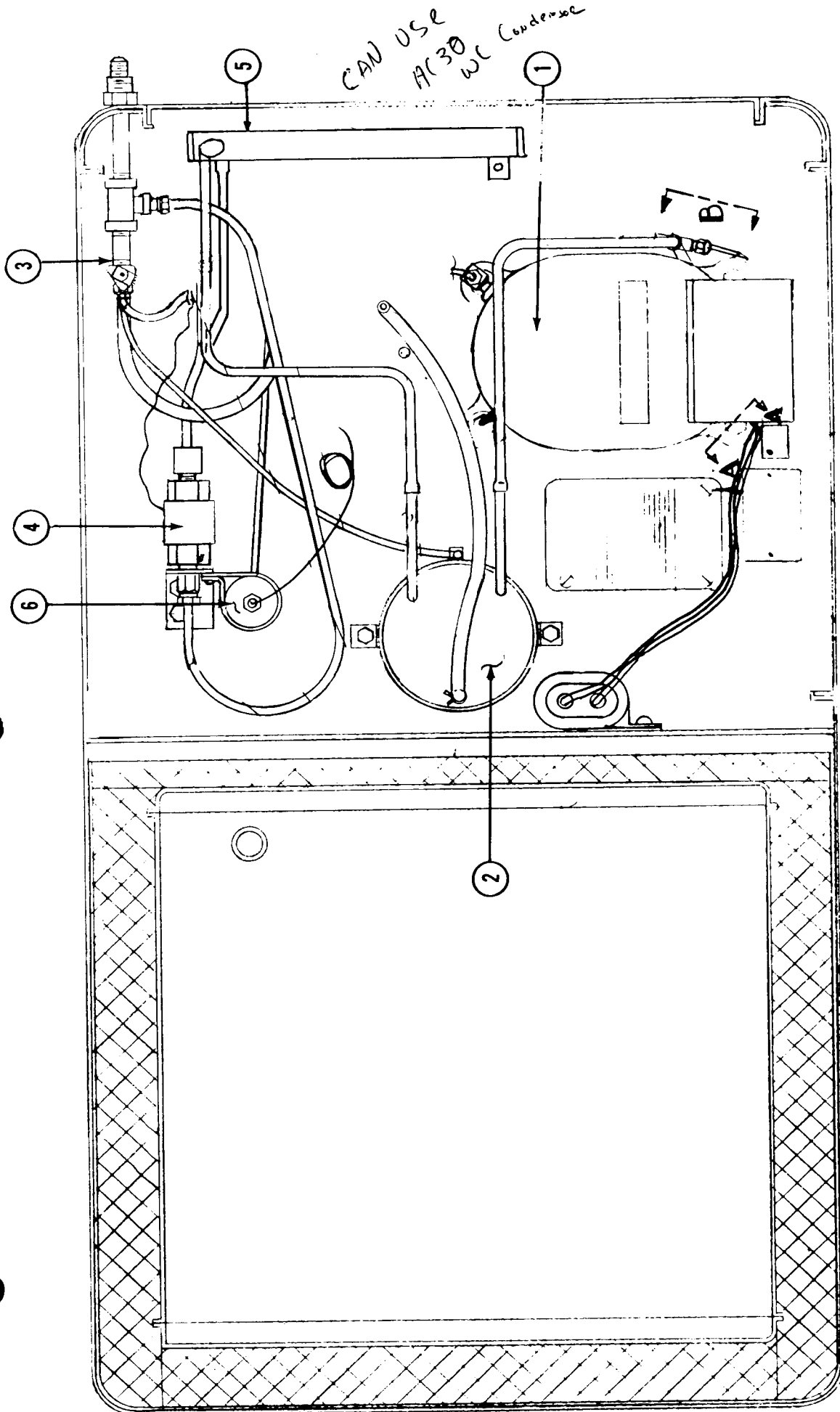

- | | |
|-----------|------------------------|
| 18-2430 | Motor Compressor |
| A-20161 | Warm Water Tank |
| 12-1434-1 | Inlet Water Solenoid |
| 11-198 | Water Regulating Valve |
| 18-354 | Water Cooled Condenser |
| 2-544 | Refrigerant Drier |
-
- | | |
|----|------------------------|
| 1. | Motor Compressor |
| 2. | Warm Water Tank |
| 3. | Inlet Water Solenoid |
| 4. | Water Regulating Valve |
| 5. | Water Cooled Condenser |
| 6. | Refrigerant Drier |

CABINET TOP VIEW

SM-205WJ

CABINET FRONT – END VIEWS

- 1. 2-1741
- 2. 2-1742
- 3. 2-932
- 4. 2-785
- 5. 13-617-11
- 6. 13-674-8

- 7. 12-1532-1
- 8. 12-675-1
- 11. A17954-1
- 12. A-19555
- 13. 13-590
- 14. A-16108

- Water Pump
- Agitator Motor
- Three Way Water Valve
- Bulb Cover
- Cover Gasket
- Holder Buttons (2)

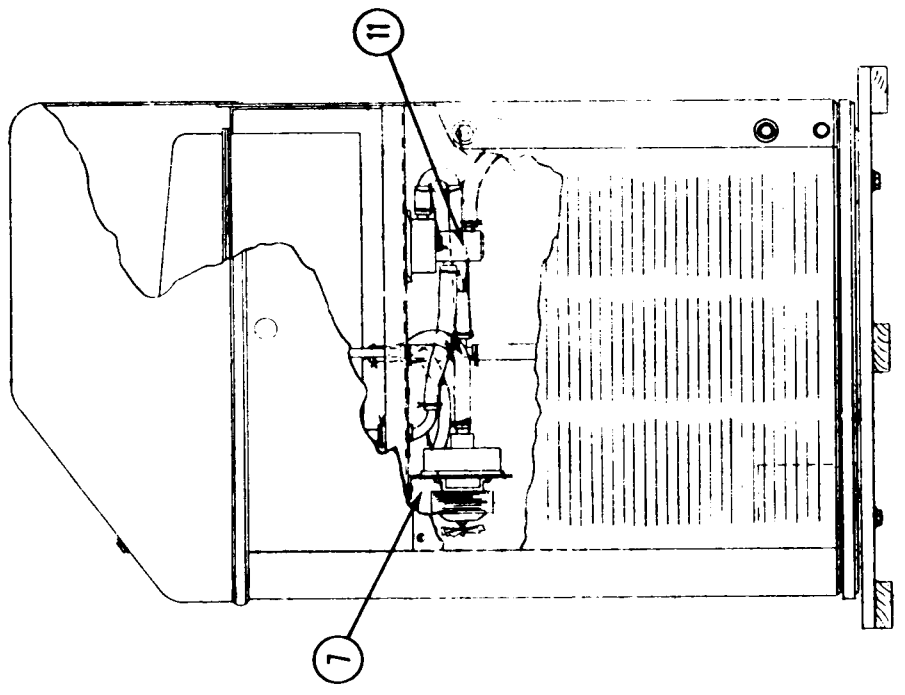
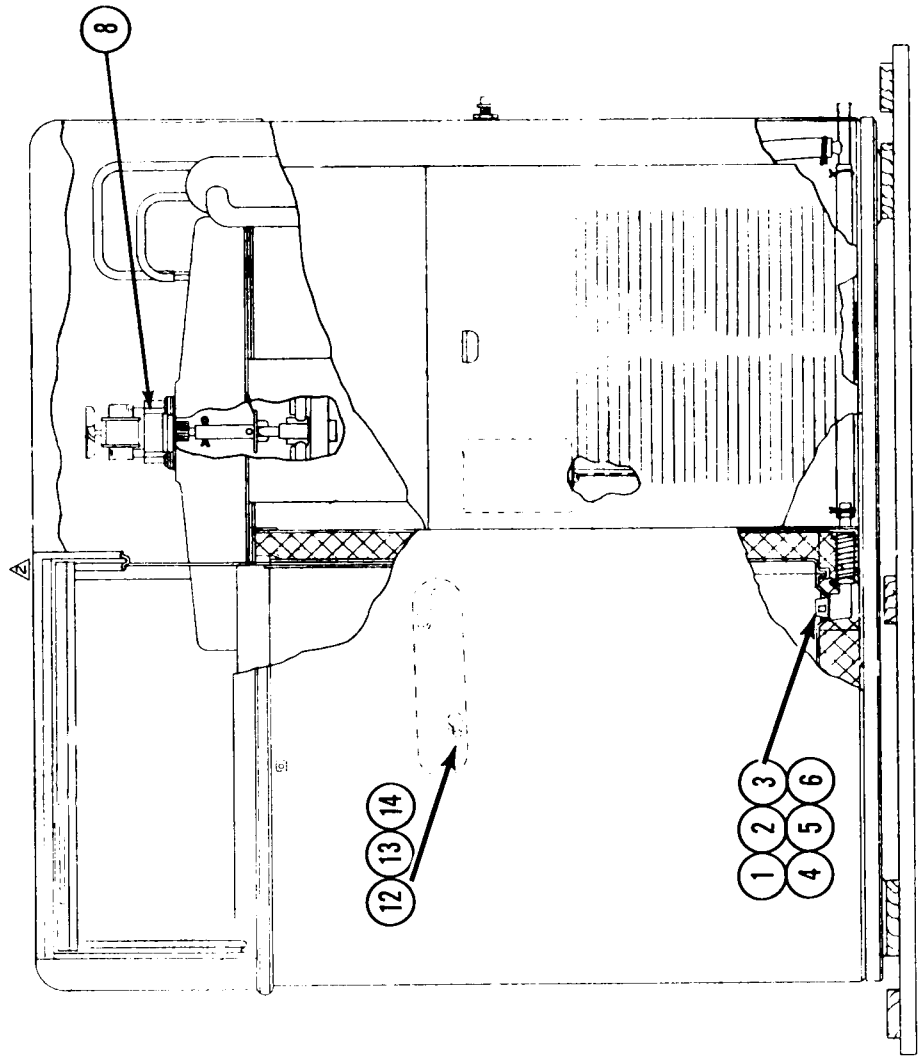

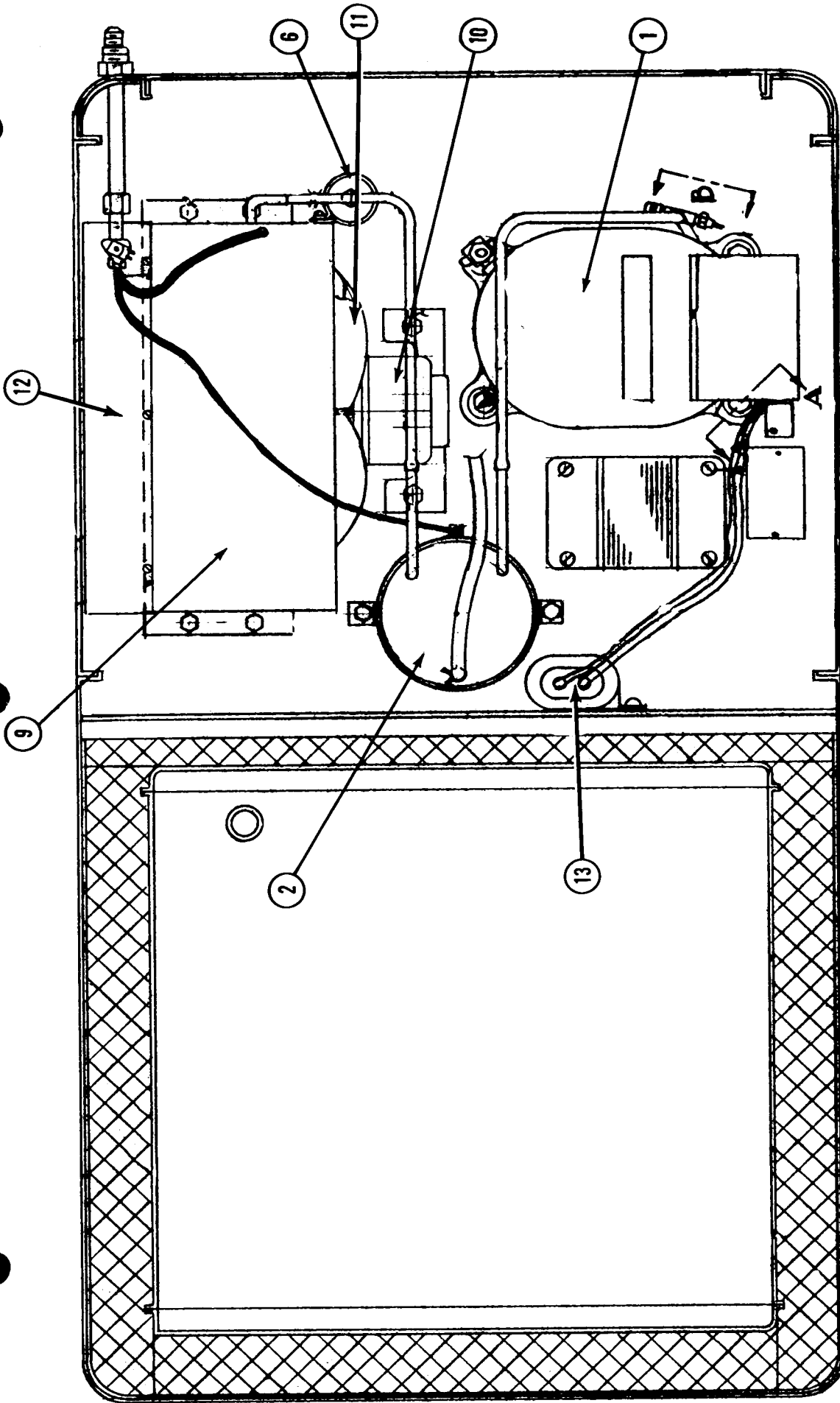

- | | | |
|-----|------------|----------------------|
| 1. | 18-2430 | Motor Compressor |
| 2. | A-20161 | Warm Water Tank |
| 6. | 2-544 | Refrigerant Drier |
| 9. | 18-334 | Air Cooled Condenser |
| 10. | 12-1681-1 | Fan Motor |
| 11. | 18-625 | Fan Blade |
| 12. | A-21355 | Shroud Extension |
| 13. | 18-1902-17 | Running Capacitor |

CABINET TOP VIEW

CASE PARTS

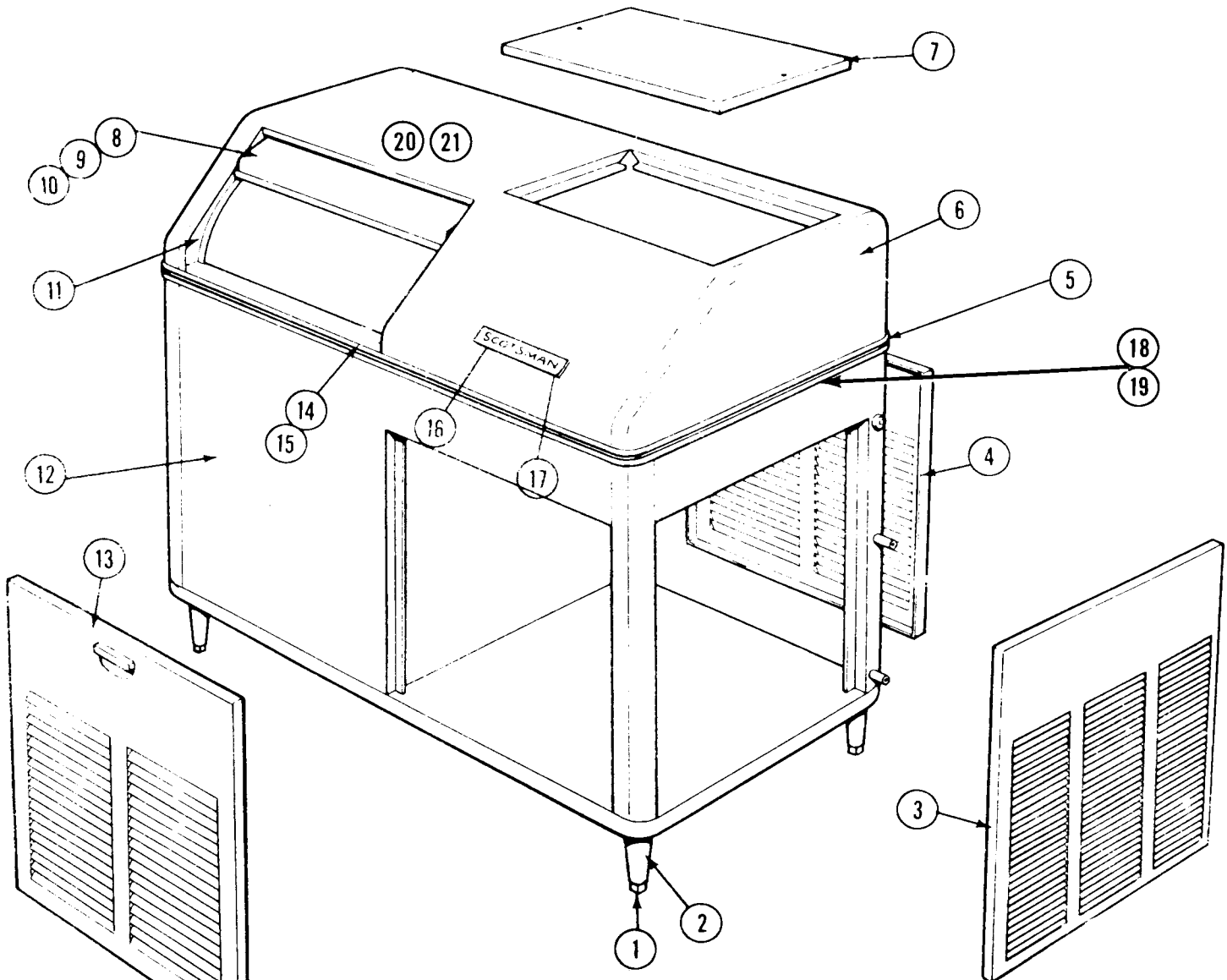

- | | | |
|-----|----------|------------------------------|
| 1. | 8-522 | Leg Levelers |
| 2. | A-15803 | Leg |
| 3. | S-6840 | Side Door |
| 4. | A-8739 | Back Door |
| 5. | A-5862 | Rear Moulding Strip |
| 6. | A-19852 | Hood (less doors) |
| 7. | A-7676 | Top Door |
| 8. | A-15559 | Sliding Door |
| 9. | 3-640 | Door Glide |
| 10. | 2-1616 | Door Catch |
| 11. | A-16208 | Door Track |
| 12. | A-19520 | Case Ass'y (less doors) |
| 13. | A-15866 | Front Door |
| 14. | A-5863 | Moulding Strip |
| 15. | 15-324 | Plastic Insert - per foot |
| 16. | 15-156 | Emblem |
| 17. | 3-271 | Speed Nuts |
| 18. | 3-1507 | "U" Type speed nuts 18/unit* |
| 19. | 3-1419-7 | Screws for 3-1507* |
| 20. | 2-1736 | Cable Stop* |
| 21. | 3-1276 | Wing Screw* |

* Not Shown

Add letter "S" to parts for stainless steel finish

MOTOR COMPRESSOR
Air and Water
115/60/1 3500 RPM

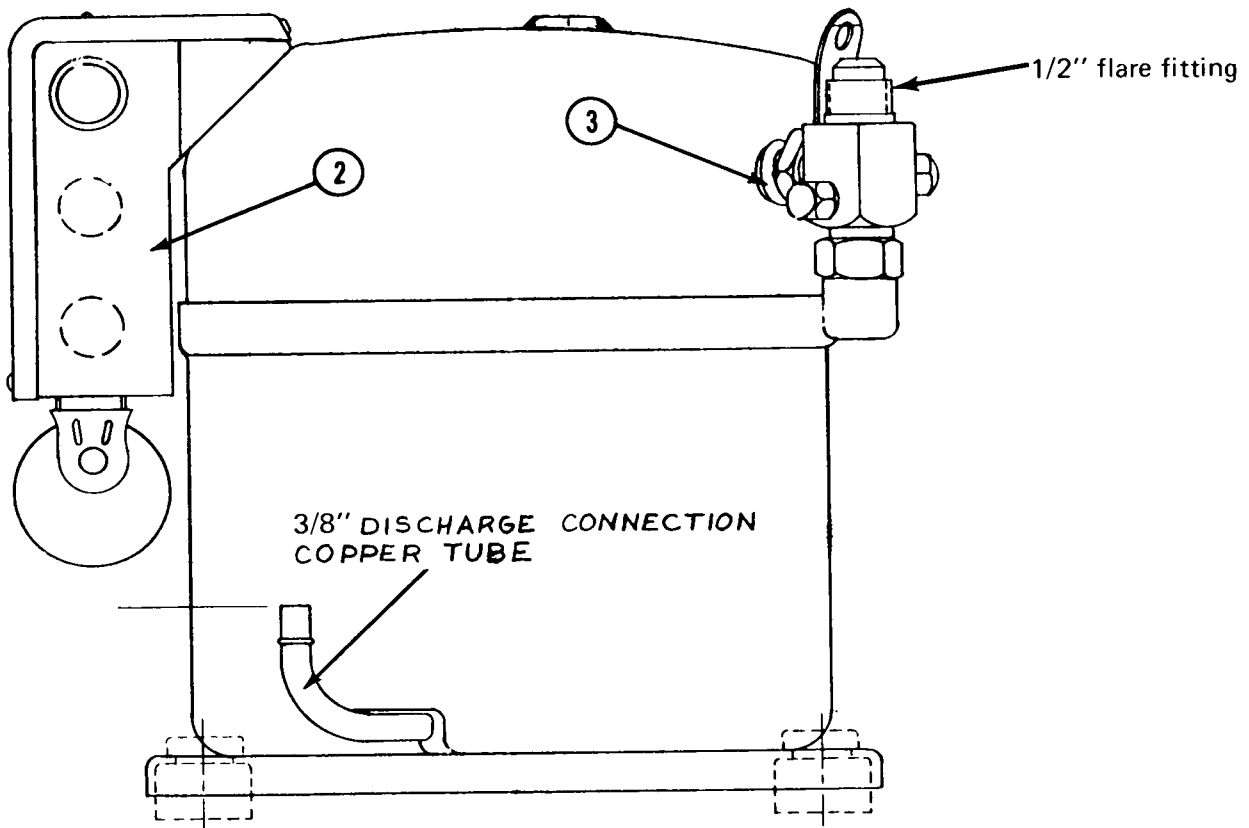
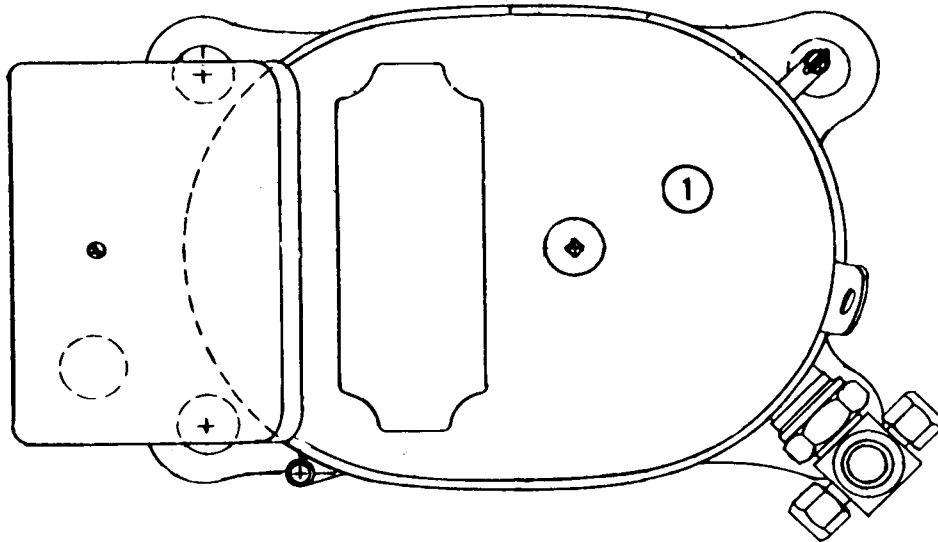

*On base — not shown.

- | | | |
|----|-------------|---|
| 1. | 18-2430 | Compressor Only Copelaweld
Model RSL2-0075-1AA |
| 2. | 18-2400-25 | Compressor Overload |
| | 18-2410 | Relay |
| | 18-2420 | Capacitor - Start |
| 3. | 18-2201-30 | Suction Valve |
| | *18-1902-17 | Capacitor - Run |
| | 18-2300-29 | Service Valve Seal |

WATER VALVE ASSEMBLY
A- 17954-1

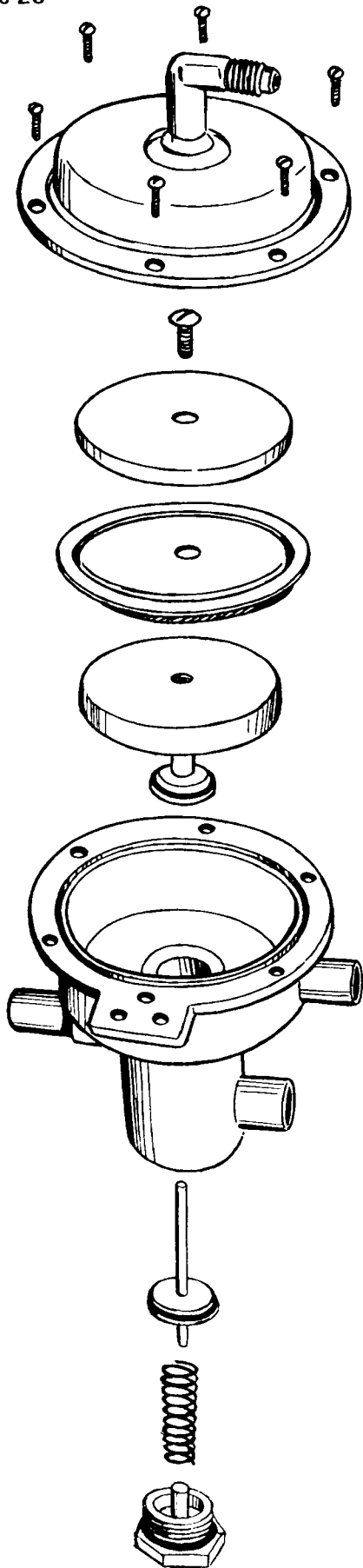

- | | | |
|-----|----------|-------------------|
| 1. | 13-617-2 | O-Ring |
| 2. | A-17937 | Valve Cap Bottom |
| 3. | 2-1545 | Spring |
| 4. | 13-617-1 | O-Ring |
| 5. | A-17942 | Lower Plunger Rod |
| 6. | 3-1403-6 | Screws (6) |
| 7. | A-17953 | Valve Top Cover |
| 8. | 3-1506-1 | Screw |
| 9. | A-17941 | Upper Plunger |
| 10. | 13-606 | Upper Diaphragm |
| 11. | A-18312 | Diaphragm Cover |
| 12. | A-17947 | Valve Body |

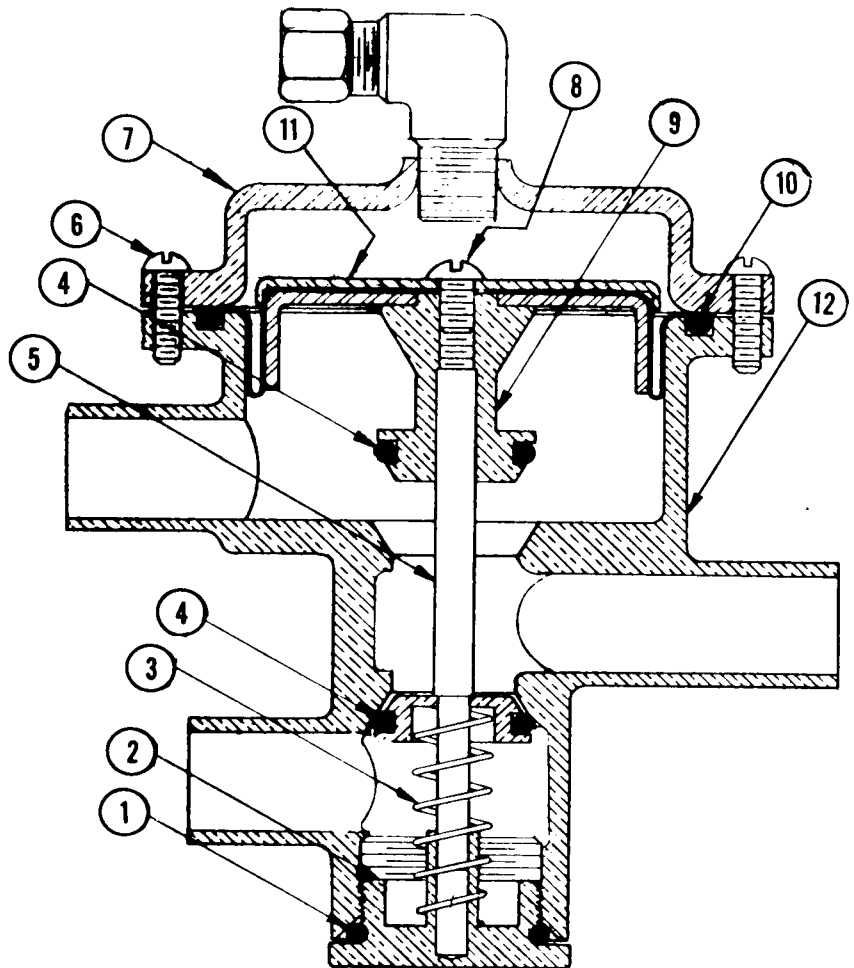

SM-205J FREEZER ASSY

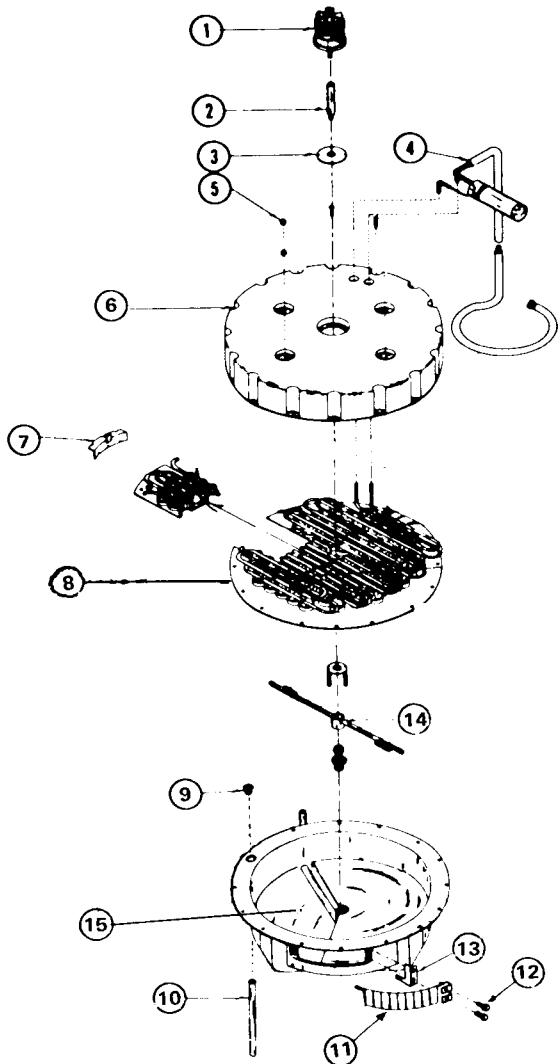

ITEM NO.	PART NO.	NAME
1.	12-675-1	Drive Motor
2.	A-6084	Drive Shaft
3.	13-176	Drive Motor Gasket
4.	A-19833	Suction Line, Cap Tube Assy
5.	3-1513	Nut (4 required)
6.	A-22439	Freezing Chamber Top
7.	A-20169	Water Baffle
8.	13-660	Rubber Cup Holder
9.	S-7434	Adaptor
10.	A-16238	Hot Water Tube
11.	A-19541	Curtain Assy.
12.	S-7234	Cap Nuts (2 required)
13.	S-7730	Cube Stopper
14.	A-18361	Spray Bar
15.	2-1672	Plastic Inner Bottom

Complete Freezer in crate, less item No. 1, 2, 3.

A-22440-2

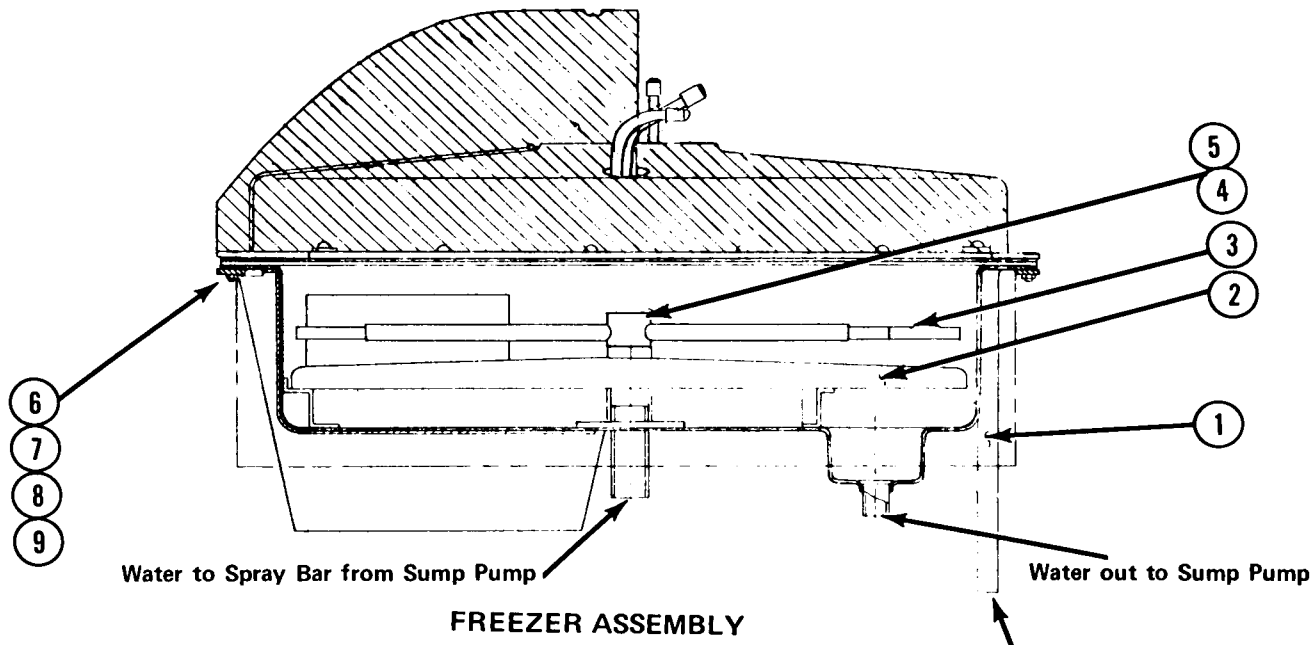
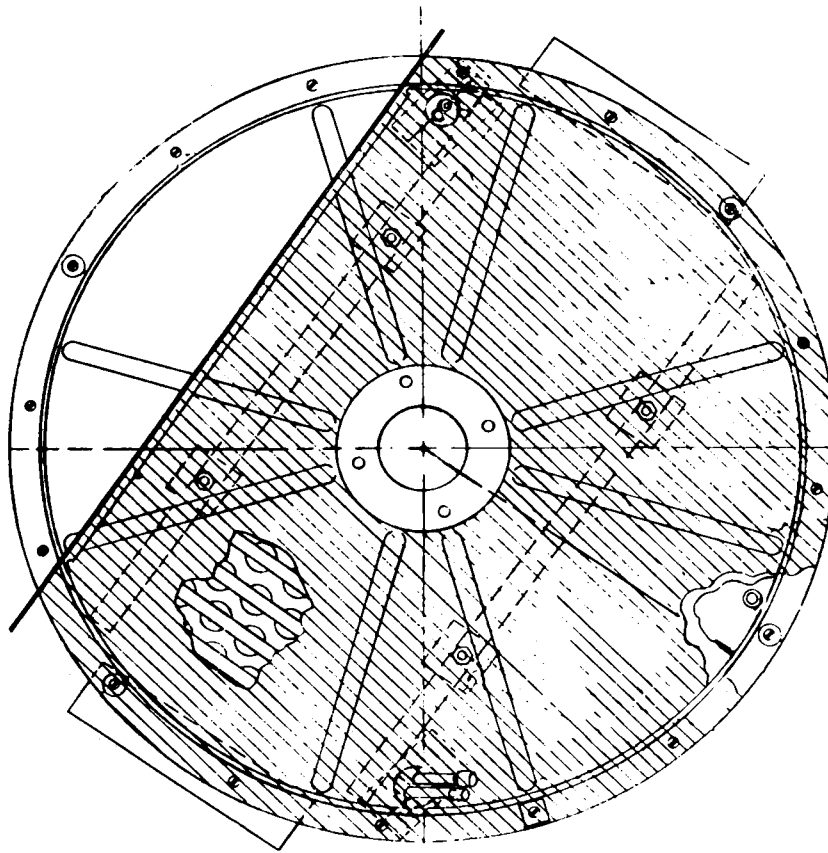

FREEZER ASSEMBLY

- | | | |
|----|-----------|---------------------------------|
| 1. | A-16238 | Warm water tube |
| 2. | 2-1672 | Plastic Inner Pan |
| 3. | A-18361 | Spray Bar, Complete |
| 4. | A-19508 | Jet Bearing Shaft |
| 5. | 2-433 | O-Ring |
| 6. | 3-1403-31 | Screw 16/unit |
| 7. | 3-1406-6 | Nut 16/unit |
| 8. | 3-1417-5 | Washer 16/unit |
| 9. | A-5839 | Bolt Reinforcement Plate 8/unit |

Warm water in from 3 Way Valve

Water to Spray Bar from Sump Pump

Water out to Sump Pump

DRIVE LINKAGE AND SPRAY BAR

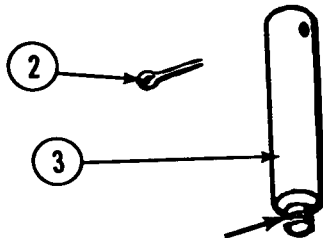
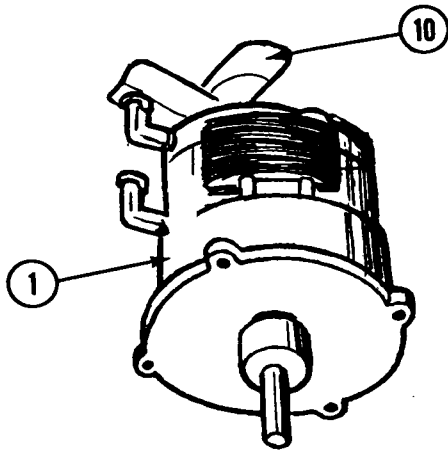

- | | | |
|-----|-----------|-----------------------|
| 1. | A-23390-1 | Drive Motor |
| 2. | 3-290 | Cotter Key |
| 3. | A-6084 | Drive Shaft |
| 4. | S-6900 | Drive Arm |
| 5. | S-7315 | Rubber Covers |
| 6. | A-18361 | Spray Bar, Complete |
| 7. | 2-433 | "O" Ring |
| 8. | A-19508 | Inlet & Bearing Assy. |
| 9. | 2-1803-1 | Jets 10/units |
| 10. | 12-675-25 | Fan Blade |
| 11. | 13-653 | Rubber Spray Bar Tips |

Note: Left Hand Thread

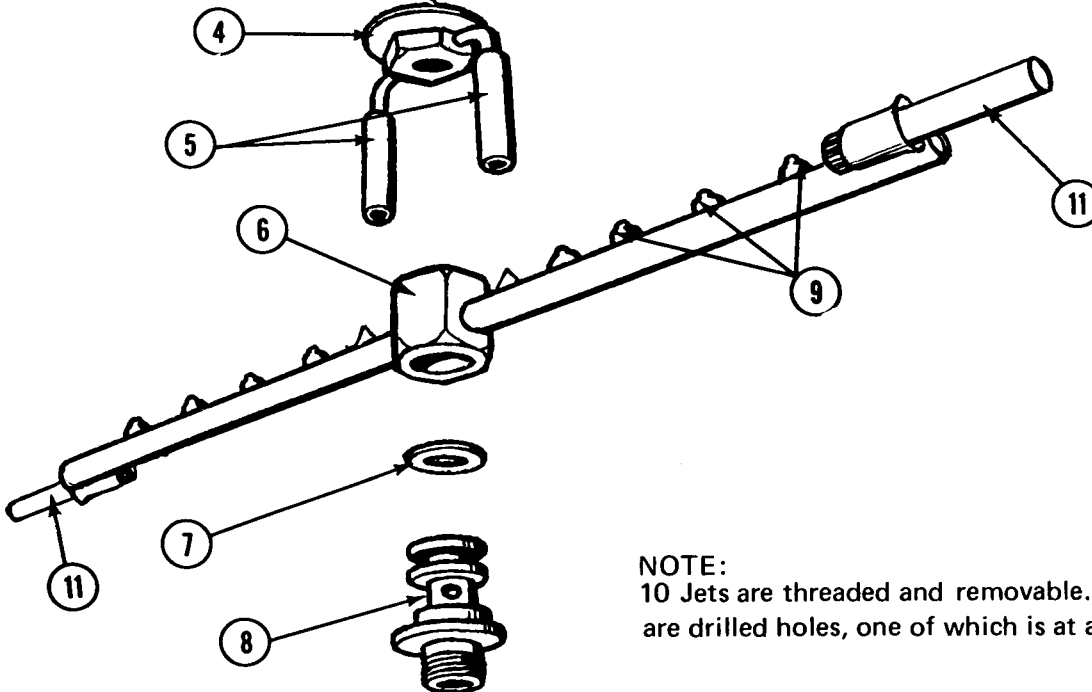

NOTE:
10 Jets are threaded and removable. Jets in end pieces are drilled holes, one of which is at a 20° angle.

FUNCTIONAL PARTS DESCRIPTION

- 11-365 Fan cycle - head pressure control
Robert Shaw No. A P 20-1066
120 lb. 140 lb. Range
Automatic reset - SPST Nonadjustable
- 11-353 Bin Thermostat
Cutler Hammer No 9530 N 213
Cut Off 35° cut in 39°
Adjustable calibrate for altitude over 2000 ft.
- 11-357 High pressure Cut off – Water Cooled models
Robert Shaw No. A P 21-2048
Control opens 190 lb. P.S.I.
Manual re-set - Adjustable
- 12-419 Relay - (by passes thermostat during freezing cycle)
Potter - Brumfield No. PR5AY
115/60/1 - SPDT Rated 25 amps
- 11-345 Cube size thermostat
Ranco A11-377
Reverse acting, closes on temperature
Decrease - Has adjustment dial
- 12-1598 Relay 115/60/1
Ameco or Potter Bumfield
3 PDT No. KU-14A-15
Holds cuber drive motor thru Harvest cycle
- 18-354 Water cooled condenser W.C. models only
Halstead-Mitchell No. EL-75
- 12-1532-1 Water recirculating, sump pump
Hartell Inc.
3000 RPM - shaded pole, thermally
protected motor - 1/25 H.P. 115/60/1
- 18-2430 Motor compressor 115/60/1
Copeland refrigeration - Copelaweld RSL2-0075-1AA
2 Pole, 3500 RPM Hermetic for use with refrigerant R-12
- A-21038-1 Finishing Clock or Timer
2-1721-51 Knob assembly
2-1721-50 Micro switch.
- 12-1434-1 Water inlet solenoid
Detroit Controls Corp. No. S-30-A
115/60/1 coil - Nylon body
1/4" MPT inlet & outlet No flow control.
Also American Standard Control No. SSV-20206
- 18-1902-17 Running Capacitor
Copeland Refrigeration No. 014-0001-00
10 Microfarad rating

SERVICE – COMPLETE UNIT

ALL STEPS LISTED BELOW SHOULD ONLY BE STARTED WHEN WATER AND ELECTRICAL SUPPLY ARE OFF TO PREVENT ACCIDENTS.

To remove cabinet top or hood.

1. Remove two back end screws in rear moulding strip.
2. Pull out black insert tape concealing screws.
3. Remove balance of screws in moulding strips.
4. Lift hood straight up.

To remove Sump Pump.

1. Remove lower right side service panel.
2. Disconnect hose clamp on goose neck.
3. Remove electrical lead to control box.
4. Remove 2 screws in pump mounting bracket.

To remove Drive motor

1. Remove hood top panel.
2. Disconnect electrical cord connectors from motor coil.
3. Reach in through curtained opening and remove drive fork from drive shaft attached to motor. Note drive fork has left hand thread.
4. Remove 4 screws holding drive motor to freezer dome and pull drive motor shaft out.

To remove the Jet Tube assembly

1. Reach in through storage bin sliding door and remove two brass thumb screws holding plastic curtain closed.
2. Open curtain on hinge and reach hand into opening, feeling for spray bar.
3. Follow spray bar to center hub, turn spray bar so one end points towards curtain opening. Now lift straight up on spray bar and out, after spray bar comes off center hub.

To remove Three Way Water Valve

1. Remove lower front right side service door.
2. Remove all hose clamps to water valve.
3. Remove upper water line connection to elbow on top valve housing.
4. Loosen two nut and bolt assemblies holding valve to mounting bracket. Water valve now drops free.
5. Replace in reverse of above.

To replace Storage Bin Door

1. Lift door up and slide back as you normally would to remove ice from bin.
2. Remove screw at center rear edge of door where it is attached to lanyard.
3. Pull door straight out.
4. Install repaired or new door in reverse of step number 2 above.

MAINTENANCE INSTRUCTION FOR SCOTSMAN SUPER CUBERS

THE FOLLOWING MAINTENANCE SHOULD BE SCHEDULED EACH (6) SIX MONTHS ON ALL SCOTSMAN SUPER CUBERS. CALL YOUR AUTHORIZED SCOTSMAN SERVICE DEPARTMENT.

1. Clean air-cooled condenser; This is to be done frequently with the machine shut off.
2. Clean water system and evaporator, sump tank and screen, using Scotsman Ice Machine Cleaner or equivalent.
3. Remove jet tube and manually clean jets by unscrewing jets.
4. Check curtain assembly.
5. Tighten all electrical connections.
6. Tighten all bolts.
7. Check water supply. Check water pressure flow through flow control. Clean water strainer.
8. Oil jet tubes drive motor three (3) places. Use SAE 20 oil - 3 oil cups.
9. Oil Condenser fan motor. Punch sealed cap or remove screws where possible.
10. Check for refrigeration leaks with halide torch.
11. Check for water leaks. Tighten drain line connections.
12. Check size and condition of cubes. Adjust as required. See Service Analysis Section.
13. Check bin thermostat setting. Factory set at 35° out, 39° in.

PROCEDURE FOR USE OF SCOTSMAN ICE MACHINE CLEANER

1. Remove lower front access door.
2. Locate control box with time clock knob protruding thru cover.
3. Put unit through a harvest cycle manually. This may be done by turning time clock knob clockwise until a loud snap is heard.
4. Let unit finish cube harvest cycle and start into freezing cycle. This will be approximately 5 minutes after the loud snap in Step No. 3 is heard. At this time turn the compressor switch off, the lower of the two switches in the control box.
5. Locate the sump reservoir which is in the storage bin area and directly behind the ice discharge chute. This discharge chute is covered by a series of white plastic curtains which are free to swing out into the storage bin. Pour 4 ounces (half bottle) of "Scotsman Ice Machine Cleaner" into the sump reservoir.
6. Let unit operate normally for 10-15 minutes into the freezing cycle. No ice will be made because the motor compressor is not in operation.
7. At the end of this time put the unit through 2 or 3 harvest cycles manually to allow fresh make up water to clean out remaining solution. Each time waiting approximately 5 minutes after the loud snap until the next harvest cycle is done manually.
8. Turn the compressor switch back on.
9. Check each new batch of cubes until they are clear and until acid taste has been removed from cubes.
10. Put hot water in storage bin to melt the cubes and thereby clean the drains with the same solution that has just cleaned the unit.
11. Use a damp cloth to wipe off curtains and inside of storage bin.
12. Replace lower front access door.
13. Unit is now ready for continued automatic operation.