

# TABLE OF CONTENTS

Section  
SM105  
Page 2

Foreward	1
Table of Contents	2
Photograph and Ice Making Capacity	3
Specifications and Dimensions	4-5
Selecting Location:	
Location	6
Uncrating	6
Preparation for Installation	6-7
Installation	7-8
Water Supply and Drain	8
Electrical Connection and Characteristics	8
Wiring Diagrams	
Air Cooled	9
Water Cooled	10
Diagram Plumbing Connections	11
Final Check List	12
Start-up	13-14
Cycle of Operation:	
Harvest Cycle	15-16
Freezing Cycle	17-18
Service Analysis Charts	19-20
Exploded Views - Component Parts:	
Sump Pump	21
Water Valve Assembly	22
Control Box	23
Complete Unit (End View)	24
Complete Unit (Front View)	25
Case Parts	26
Condensing Unit (Air Cooled)	27
Condensing Unit (Water Cooled)	28
Service Information	
Drive Linkage	29
Spray Bar Ass'Y.	30
Functional Parts and Maintenance	31
Service Complete Unit	32
Maintenance Instructions	33
Parts List	34-35

**THIS PAGE  
INTENTIONALLY  
LEFT BLANK**

**THIS PAGE  
INTENTIONALLY  
LEFT BLANK**

# SCOTSMAN®

Section  
SM105  
Page 3

## SUPER CUBER SM-105 SERIES

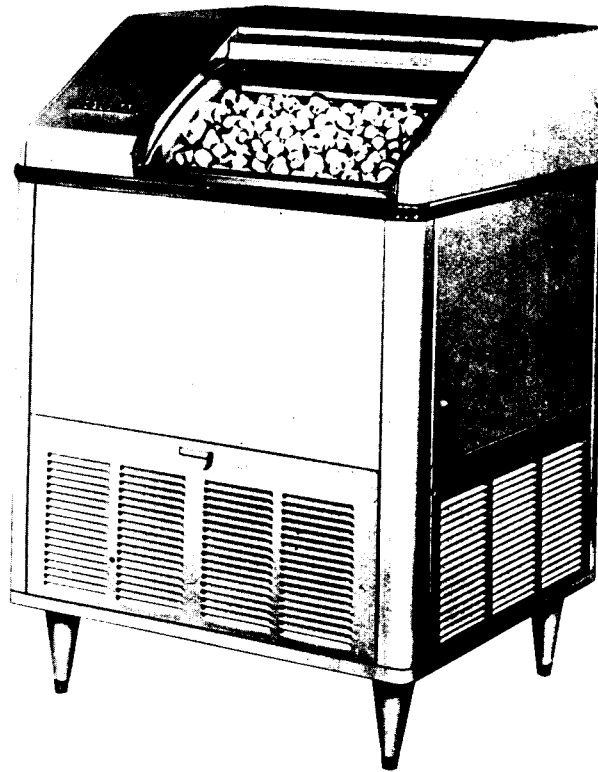

### ice making capacity

Air Cooled Models

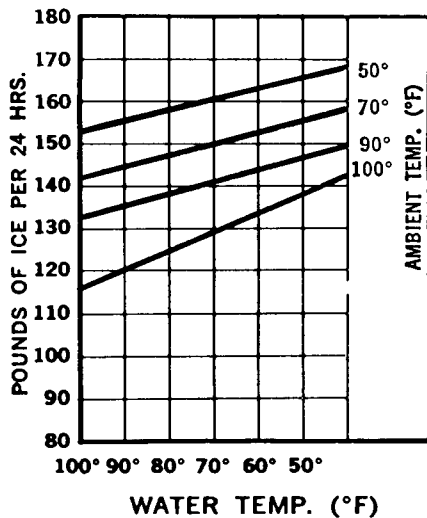

Water Cooled Models

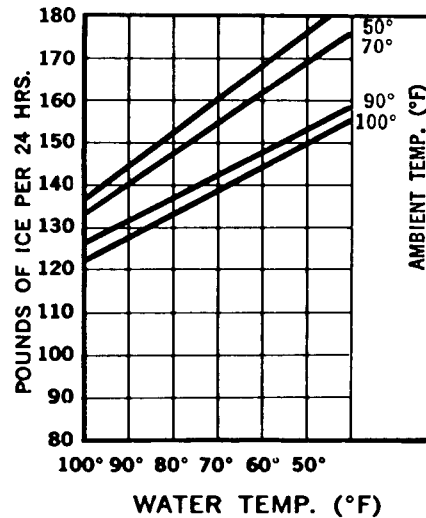

## SPECIFICATIONS

SUPER CUBER SM105 SERIES	SM-105J	SM-105WJ	SM-105J-SS	SM105WJSS
CONDENSER, Air Cooled	X		X	
CONDENSER, Water Cooled		X		X
WATER DRAIN, Condenser - $\frac{5}{8}$ " O.D.		X		X
FINISH, Hammerloid Grey	X	X		
FINISH, Stainless Steel			X	X
SHIPPING WEIGHT	319	325	326	330

DAILY CAPACITY up to 150 lbs.  
 STORAGE BIN CAPACITY (Self-Contained) 50 lbs.  
 COMPRESSOR  $\frac{1}{2}$  H.P.  
 ELECTRICAL 115 V, 60 CY, 1 PH  
 WATER INLET,  $\frac{3}{8}$ " SAE Flare  
 WATER DRAIN, Bin -  $\frac{5}{8}$ " O.D.

STORAGE BIN, Stainless Steel  
 HEIGHT (with legs) -  $45\frac{1}{4}$ " to 46"  
 HEIGHT (without legs) -  $39\frac{1}{4}$ "  
 WIDTH -  $34\frac{1}{8}$ "  
 DEPTH -  $24\frac{1}{2}$ "

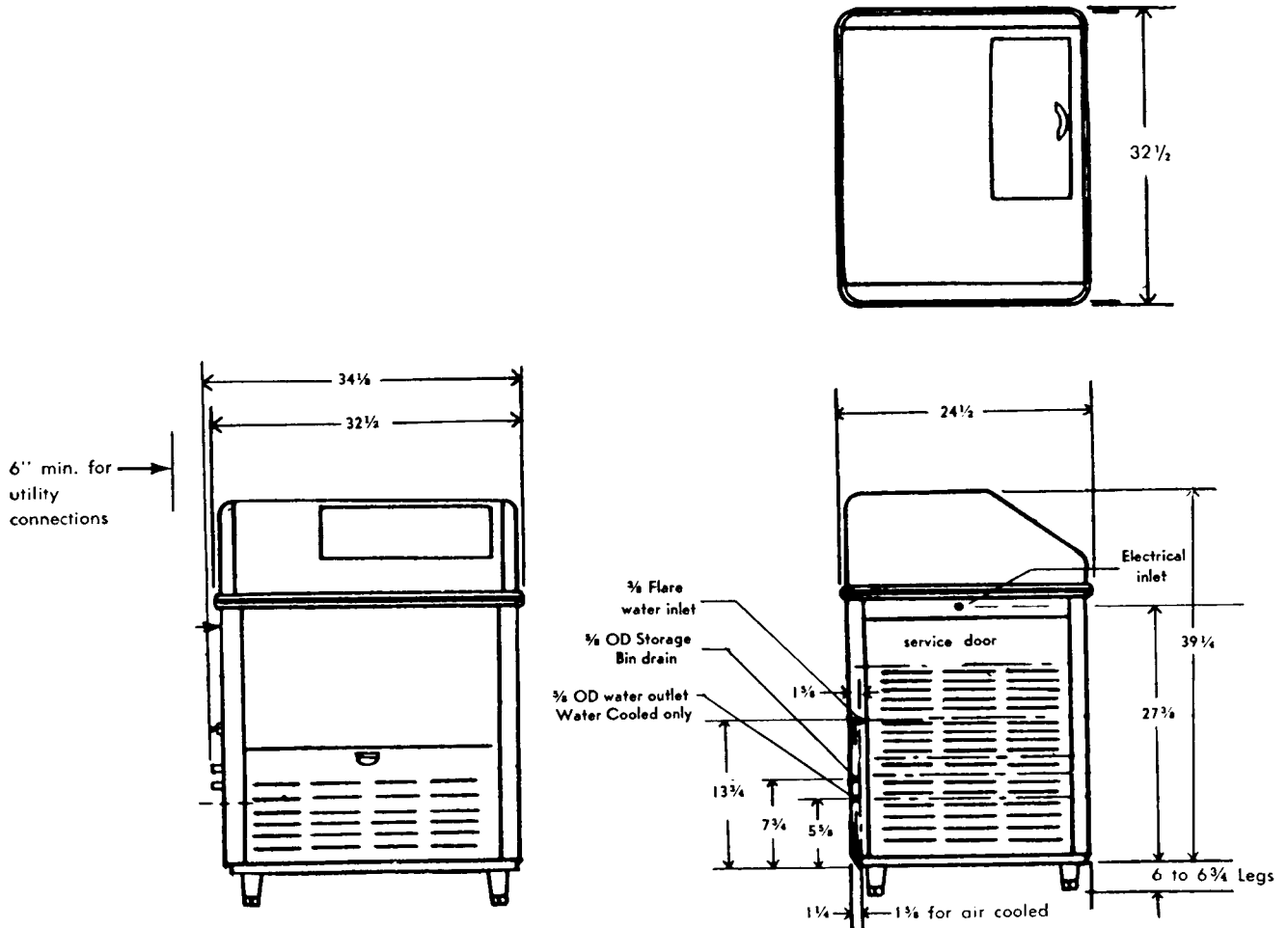

SPECIFICATIONS

	SM105J-1	SM105WJ-1
Compressor - Copeland	RSF-0050-1AA	Same
Volts & Hertz	115 v-60	115 v-60
Amperes	11.2	11.2
Fan - Wattage	7.0	None
Sump Pump Amperes	2	2
Spray Bar Motor - Wattage	35	35
Defrost - Warm Water Heated By	Hot Gas	Hot Gas
Total Power Consumption - Amperes	13	13
Refrigerant Type	Refrige- rant 12	Refrige- rant 12
Refrigerant Charge	28 ounces	28 ounces
Cubes Per Harvest	60 Full size Medium cubes	60 Full Size Medium cubes
Water Consumption to Produce Ice	5 Quarts per hour	5 Quarts per hour
Water Used by the Condensing Unit		45 Gallons per hour. Average- Varies with Water Temperature

DIMENSIONS

Height with 6" Legs	46"	46"
Height-Less 6" Legs	39 1/4"	39 1/4"
Width	34 1/8"	34 1/8"
Depth	24 1/2"	24 1/2"

<u>Weight</u>	<u>Shipping</u>	<u>Net</u>
SM105J	319	265
SM105WJ	325	271
SM105J-SS	326	271
SM105WJ-SS	330	275

## INSTALLATION

### UNCRATING OF MACHINE

1. The complete machine comes in one crate. After the crate is removed, inspect for concealed damage. Remove the bottom skid by removing all bolts. Then cut all wires holding support packing from refrigerant line. Be sure the compressor is snug on rubber mounts. Then check all refrigerant lines for rubbing or touching other surfaces. Also check for possible transportation damage.
2. Remove all service doors and panels.
3. Remove leg package in compartment base and install 4 legs in unit base sockets. Level unit with adjustable legs.
4. Remove protective shipping tape from bin door, freezer curtain.
5. Remove water strainer from storage package for installation in water supply line feeding unit.
6. Open electrical control box and prepare for hook up, use knock outs, cord connectors, etc. Then check unit name plate voltage against building source voltage and make sure they correspond. Caution - improper voltage supplied to units will void your warranty protection.
7. Make sure suction service valve on the condensing unit is fully back seated. Replace the valve cap after checking. All models are shipped with valve back seated. Not necessary on units equipped with Schrader Valves.
8. Make sure that the flow of air is not impeded in any way over condenser on air-cooled models. Keep condenser clean. (Check and clean the condenser monthly.)
9. Operating room temperatures are minimum 50° F. and maximum 100° F.
10. Have the installation and warranty cards been filled out sent to the factory to insure warranty protection?

## LOCATION OF THE ICE CUBE MACHINE

**UNDER BAR INSTALLATIONS** - Locate, if possible, so left end panel is accessible. Locate unit so proper circulation can be attained around the unit and behind it at least four inches. Provide plumbing and electrical connections so the unit can be moved out where the entire top hood can be removed and the unit can still be operated.

**KITCHEN INSTALLATION** - As a rule, the kitchen is not the most practical place to install an air-cooled condensing unit, as grease is almost always present and makes cleaning of the condensing unit difficult. Do not locate near range or steam table or other heating devices that may be used in the kitchen.

**STOREROOM INSTALLATIONS** - Be sure storeroom is of adequate size and properly ventilated. A small, poorly ventilated room will greatly impair the efficiency of the unit. The storeroom must be kept above 50 degrees in the winter months.

**BASEMENT INSTALLATIONS** - Locate machine in the coolest place. Locate the machine in a dry place. Keep away from furnace and boiler room. Keep away from service chutes and runways, also coal or other dust of any kind. If the machine is set over a floor drain, block the machine up enough to eliminate any possible damage to the machine.

**LOCATE THE MACHINE SO IT CAN BE SERVICED WHEN NECESSARY. ALLOW AT LEAST FOUR INCHES OF SPACE AROUND THE MACHINE FOR CIRCULATING AIR.**

**IMPORTANT: ADJUST LEVELER LEGS. MACHINE MUST BE LEVEL.**



## INSTALLATION

### WATER SUPPLY AND DRAIN CONNECTIONS

#### WATER SUPPLY

The recommended water supply line is 3/8" OD copper tubing. Connect to a cold water supply line with regular plumbing fittings with a shut-off valve installed in an accessible place between supply line and machine. The water strainer supplied with the unit should be mounted with clean-out plug down. Locate the strainer next to the machine and the arrow in the direction of the flow, as per Page 11. A 3/8" male flare connection on left corner post provides easy access.

The water supply should be installed to conform with local code.

#### DRAIN

The recommended drain; is 5/8" OD copper tubing. Sweat to drain connection (See Page 11). Must be run to open or trapped drain. If drain is a long run, allow a 1/4" pitch per foot. Drain must be installed to conform with local code.

### ELECTRICAL CONNECTIONS AND CHARACTERISTICS

SM105            110-115 V, 60 Cycle            Single Phase, 13 Amps.

All external wiring should conform with National and local code requirements. Check the voltage on the line before connecting the machine. Model SM105 requires 110-115 volts, 60 cycle, single phase.

The SM105 should be wired to a 20 Amp. circuit. Be certain that the Super Cubers are on their own circuit and individually fused. The maximum allowable voltage variation should not exceed 10% of the nameplate rating even under starting conditions. Low voltage can cause erratic operation, and may be responsible for serious damage to the overload switches and motor windings.

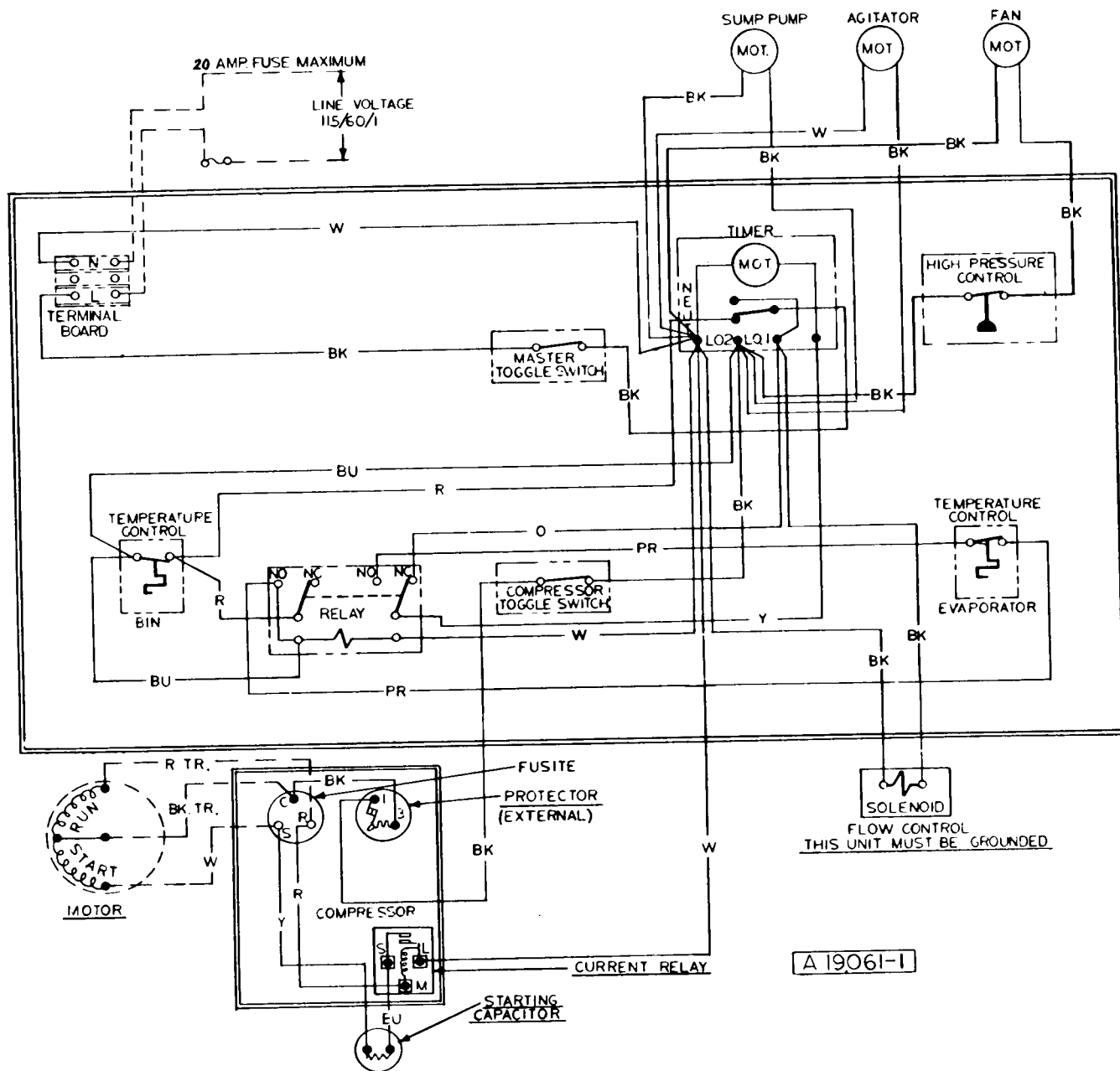

Title: Wiring Diagram  
SM105-1  
115-60-1  
Air Cooled

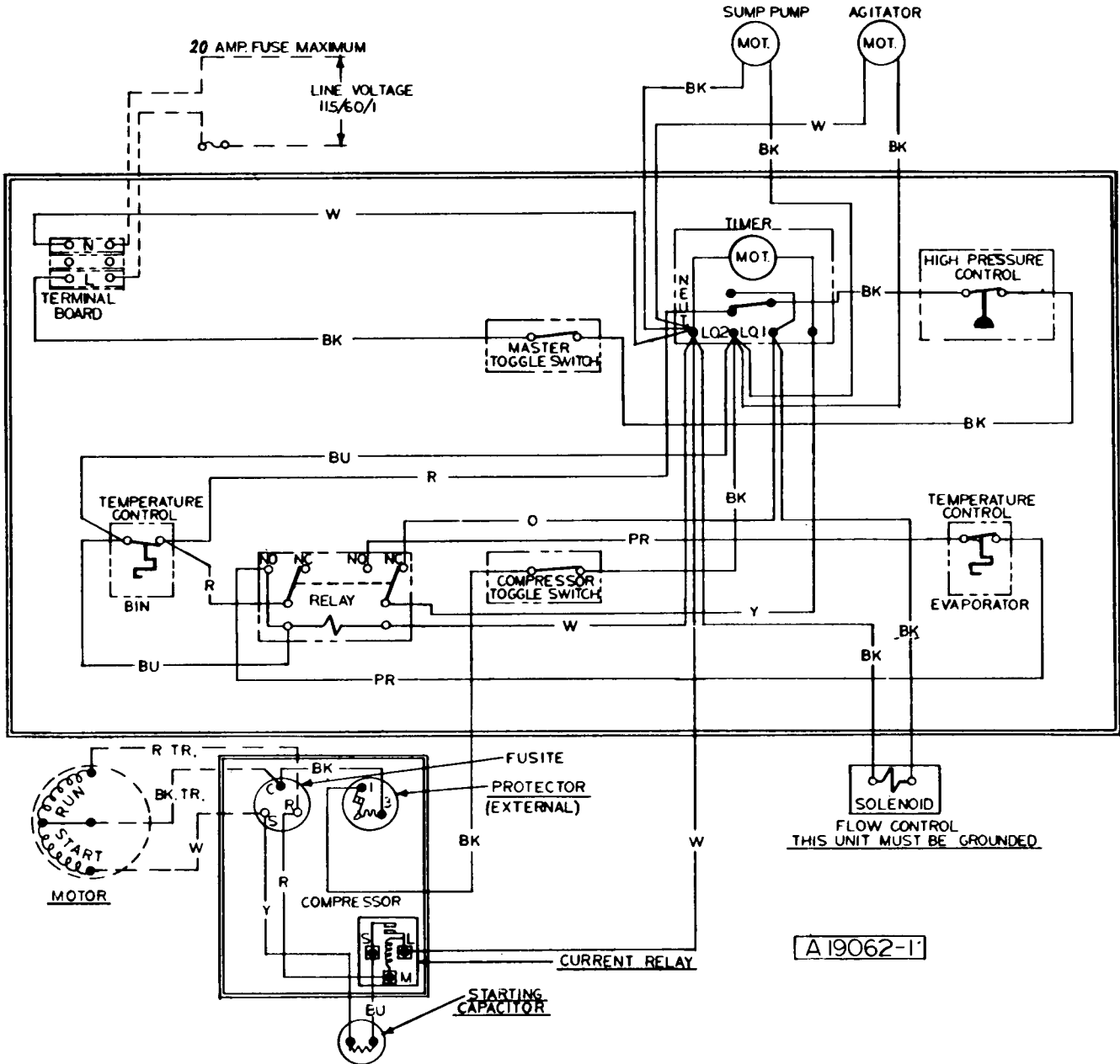

Title: Wiring Diagram  
SM105WJ-1  
115-60-1  
Water Cooled

### INSTALLATION PRACTICE

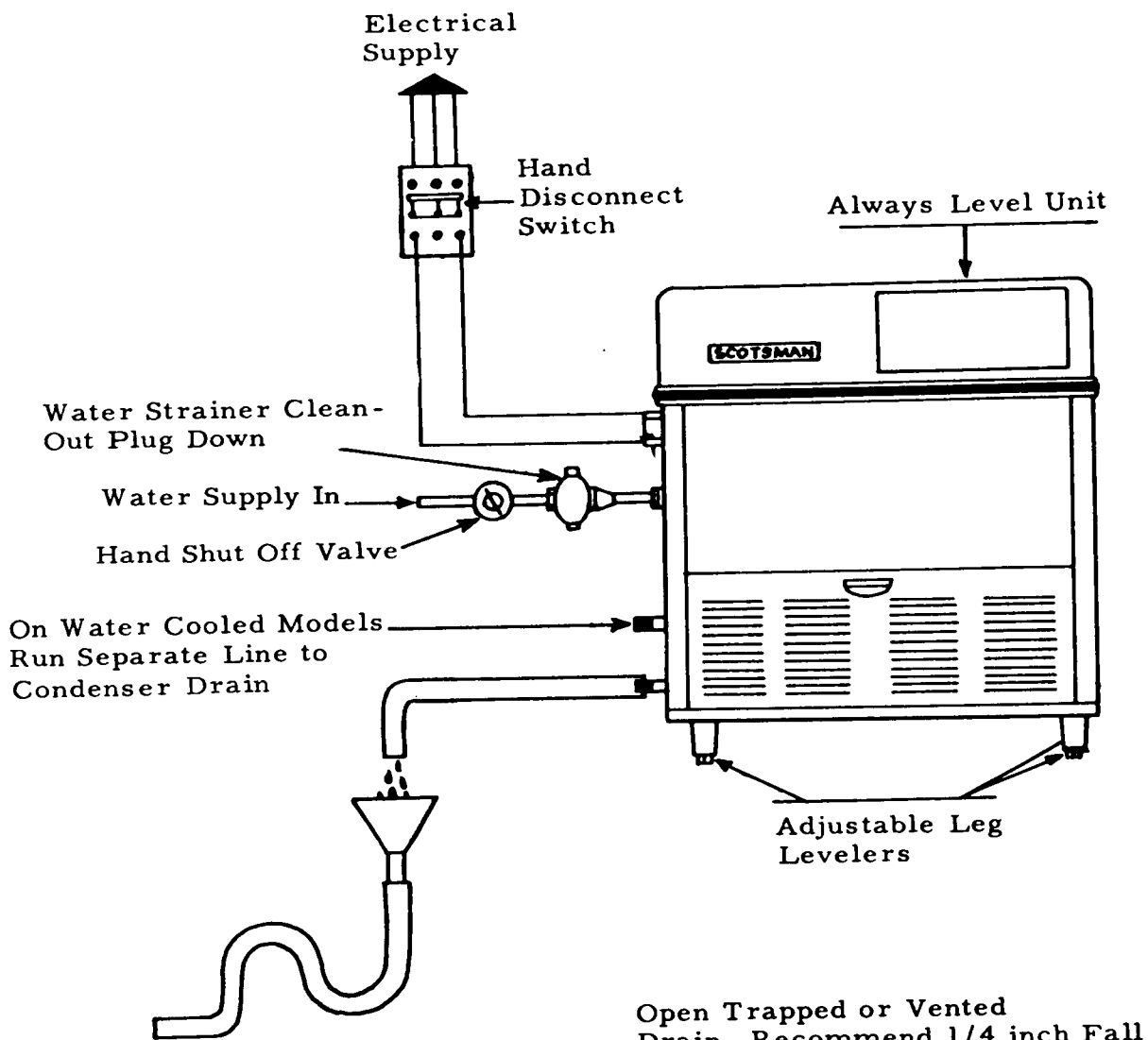

Open Trapped or Vented  
Drain. Recommend 1/4 inch Fall  
per foot of run on drain lines.

### FINAL CHECK LIST

1. Is the unit level? (IMPORTANT)
2. Have all electrical and piping connections been made?
3. Has the voltage been tested and checked against the nameplate rating?
4. Have the compressor hold-down bolts been checked to insure the compressor is snug to its mounting pads?
5. Is the water supply valve open and the electric power properly hooked up?
6. All masking tape removed from doors, panels and inner freezer curtain?
7. Is the unit clean? Has storage bin been wiped clean with cold water cloth?
8. Has the owner been given the operating manual, and has he been instructed on how to operate the machine?
9. Have the installation and warranty cards been filled out? Check for correct model and serial numbers from serial plate on unit then promptly mail card to factory.
10. Check all refrigerant and conduit lines to guard against vibrations and possible failure.
11. Is there 4" clearance behind and around unit for proper air circulation?
12. Is unit in a room where ambient temperatures are minimum 50° F. even in winter months?
13. Has water supply pressure been checked to insure at least a minimum pressure of 20 pounds?

## INSTALLATION - START UP

1. Remove lower front, and left side service doors to facilitate start up and check out.
2. Make sure water supply is turned on, then check timer finishing clock in main control box making sure the micro switch arm is resting down in offset slot in the cam (harvest position). If adjustment is necessary, turn timer knob clockwise into harvest position.
3. Inspect components in electrical control box, check for loose or frayed wire, then turn both manual switches to "on" position. All cubers have two manual on-off switches. One is for motor compressor only during cleaning operation, one is master switch for complete unit.
4. When both switches are thrown "on", water inlet solenoid will be energized allowing water to enter cuber, thru warm water tank, 3 way water valve and up into front side of freezer cup section. This will "fill" icemaker for the freezing cycle- Check operation of spray bar drive motor thru left side service door.
5. Allow clock to carry unit through harvest cycle. This will be Approximately three minutes. Dial pointer should be set on Number 2 1/2. After the compressor starts, turn the dial completely around and send it through another harvest cycle. Do this several times. This will completely flush out machine of any dust that may have accumulated in shipment.
6. After machine has been properly flushed, allow it to go into a freezing cycle-check for possible water leaks, check sump pump operation - should be running freely. Also note if jet tube operation is correct, and that none of the jets are plugged.
7. Time clock dial does not rotate at the end of the harvest cycle; it is started later by the cube size thermostat control located in the control box.
8. Freezing time will be approximately 22minutes in a 70 degree ambient. (Longer if above, and shorter if below.) Average complete cycle time is 25 minutes.
9. Watch first cube harvest and check to make sure that plastic curtain sections have not been damaged in shipment. Also that curtains do not swing back into freezer and catch on cube racks.
10. Check size of cubes made: If too small, after a second cycle, adjust cube size control to lower or colder setting - until desired cube size is reached. Normal cube size is with a 3/8" depression in crown.

## INSTALLATION

11. Check texture of cubes made: Partially cloudy cubes throughout suggest unit running short of water near end of freezing, or possibly an extremely bad water condition, which would indicate use of filtering or purifying equipment. Contact SCOTSMAN - Queen Products, Div., Ice Machine Service Department, Albert Lea, Minnesota, for further details.
12. With unit on harvest cycle, take a handful of cubes made and hold on storage bin thermostat cover. Should cut unit off at end of harvest cycle. Remove ice, unit should cut back on automatically in 3 or 4 minutes. Thermostat is factory set at 35 degrees out, 39 degrees in.
13. Install gauges and check head and back pressure: air-cooled models, head pressure after twenty minutes of freezing cycle at 70° ambient will be approximately 125 pounds PSI. The back pressure starts out at approximately 50 pounds PSI and gradually pulls down to approximately 4 pounds PSI just before harvest cycle. Higher ambients and dirty condenser will cause higher pressures. Water-cooled models have water regulating valves factory set at 135 pounds PSI: check reading and adjust if necessary. Back pressure will operate the same as on air-cooled models.
14. Remove gauges, replace control box cover and all service panels.
15. Instruct owner on how to operate and clean machine.

## HARVEST CYCLE

At the end of the freezing cycle the time clock operated switch opens compressor, sump pump and fan motor circuit, and closes circuit to time clock motor and solenoid operated inlet water valve. Inlet water pressure at bottom of hot water tank now forces heated water out the top of tank through warm water tubing and into front side of evaporator cup section. At the same time the surplus water from the preceding batch of ice cubes goes through three way water valve and off to drain. Water from the hot water tank flows into the rubber platen holding the evaporator cups and by conduction on back of cups causes the formed ice cubes to defrost or drop out. The platen-evaporator cavity is normally filled to the overflow level in 2 or 2 1/2 minutes. The amount of water running over the overflow pipe is controlled by the size of the flow control orifice and the length of the harvest time setting on the time clock past the overflow point. Overflow water goes down the drain also.

Meanwhile, cubes released drop by gravity to the inclined cube chute and thru the curtained opening into ice storage bin. At the completion of harvest cycle, the micro-switch on the timer now drops points holding defrost components in cycle and switches to freezing cycle set of contacts. Timer completes harvest cycle when microswitch arm lifts out of rear cam slot. Timer clock motor now stops and will not start again until cube size thermostat control closes once more. Electrically harvest cycle components cease, freezing cycle components start up. Chilled defrost water from the upper cavity now flows by gravity back through the three way water valve into freezer sump or reservoir pan. Here water is picked up by the water pump and continually recirculated through sprayer tube to produce the next batch of cubes.



HARVEST CYCLE SM105-J

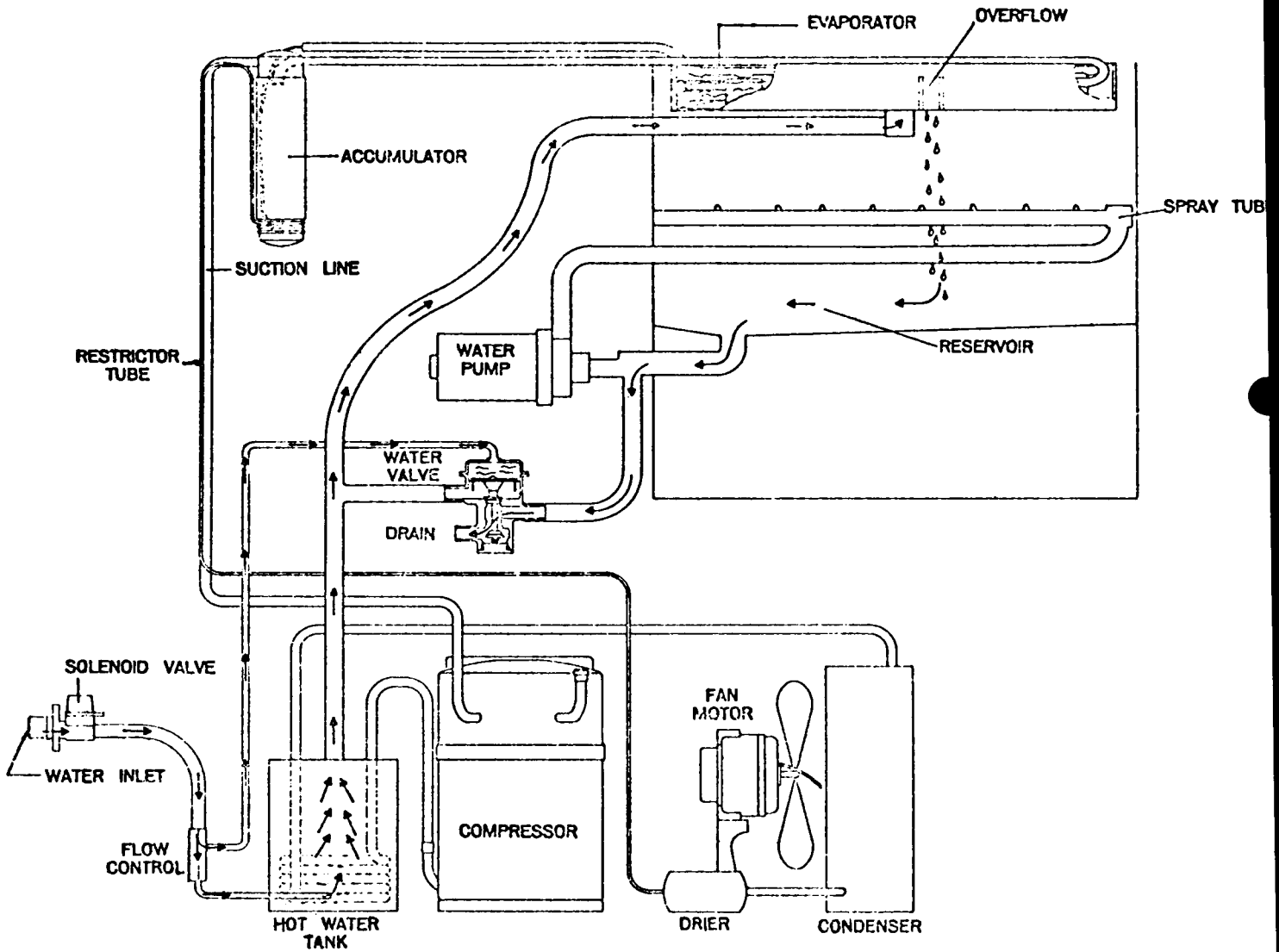

## FREEZING CYCLE

As the freezing cycle starts, electrically the components operating are the compressor and fan motor, recirculating water pump and the sprayer tube drive motor.

The refrigerant circuit which equalized at about 50 pounds gauge during the "off" or harvest cycle, thru the capillary refrigerant control, now rises rapidly to 125 - 135 pounds head pressure. The suction or low side pressure starting at 50 pounds pulls down fairly quickly to about 25 pounds at which point the ice cubes are starting to form a thin shell in cube cups. Continuing from 25 pounds slowly on down towards the finished cube pressure of approximately 5 pounds takes an average of 20-25 minutes.

During this portion of the freezing cycle the electrical brain is the reverse acting, cube size thermostat. This thermostat electrically is holding the freezing cycle components "live". When the ice cubes are about 3/4 formed, the decreasing suction pressure and temperature, activated the temperature sensing bulb of the reverse acting, cube size control, closing its contacts. This does not interrupt the freezing cycle, the closing of the cube size thermostat contacts electrically transfers the finishing of the freezing cycle to the finishing clock motor or timer as it is sometimes called. One full revolution of the timers dial is 15 minutes however of the total 15 minutes only, 3 minutes are used for the defrost or harvest cycle.

This means then that after the cube size contacts close they activate the timer motor. This control takes over and continues freezing cycle for another 12 minutes with timer dial now turning. When the 12 minutes are completed, an offset in the timer dial allows a micro switch with activating arm riding on that cam to drop into the slot electrically stopping the freezing cycle and starting the 3 minutes harvest cycle - The clock motor continues thru harvest cycles. A notch on the timer dial now lifts micro switch arm up on dial, electrically stopping harvest cycle and starts back into a new freezing cycle.

FREEZING CYCLE SM105-J

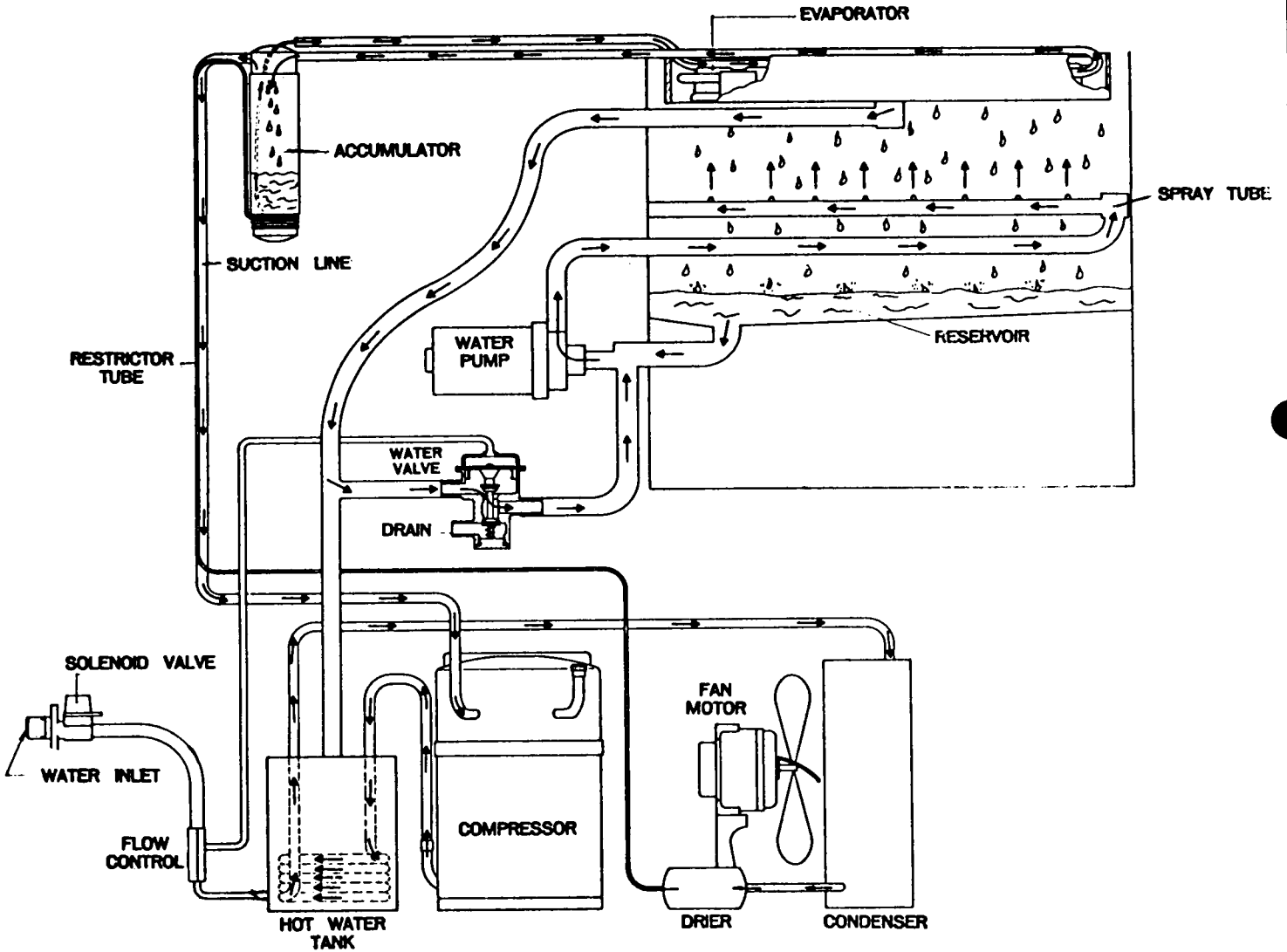

SERVICE ANALYSIS

SYMPTOM	POSSIBLE CAUSE	SUGGESTED CORRECTION
Unit will not run.	Blown fuse Bin thermostat set too high Switch in Off position Inoperative master switch Timer contacts open	Replace fuse & check for cause of blown fuse. Adjust thermostat. Set between 35° out to 39 degrees in. Turn switch to On position. Replace switch Replace timer micro-switch.
Compressor cycles intermittently	Low voltage Dirty condenser Air circulation blocked Inoperative condenser fan motor Non-condensable gases in system	Check circuit for overloading. Check voltage at the supply to the building. If low, contact the power company. Clean with vacuum cleaner, air or stiff brush. (Do NOT use wire brush.) Allow sufficient air space all around unit. Check to see if defective. If defective, replace. Purge the system.
Cubes too small	Cube size control set too high Partially restricted capillary tube. Moisture in system Shortage of water Shortage of refrigerant	Lower the setting. Turn towards colder. Blow charge, add new gas & drier. After exacuating system with suction pump. Same as above. See remedies for shortage of water. Check for leaks and recharge.
Cloudy cubes	Shortage of water Dirty water supply Restricted drain on pump Accumulated impurities	See remedies for shortage of water. Use water softener or water filter. Clean pump strainer. Use SCOTSMAN Ice Machine Cleaner.
Poor harvests	Too short defrost time Restriction in incoming water Insufficient quantity of hot water Solenoid valve not opening the water valve Air vent holes in upper cube cups plugged	Check and adjust harvest cycle. Timer should be set at 2 1/2. Check water feed line strainer and flow reducing valve. To give greater water flow increasing defrost time. Cold ambient - must be 50° minimum faulty fan control on aircooled models. Solenoid binding or burned out. Replace. Clean out holes.

SERVICE ANALYSIS

SYMPTOM	POSSIBLE CAUSE	SUGGESTED CORRECTION
Shortage of water	<p>Water spraying out through curtains</p> <p>Three-Way water valve leaking</p> <p>Water entering hot water tank too slowly</p>	<p>Replace broken curtains if any broken.</p> <p>Check the valve for foreign matter. Check valve seats and replace if necessary.</p> <p>Check pressure at source-20# required. Dirt in solenoid and flow control- blow out.</p> <p>Partial restrictions in water strainer. Clean Strainer.</p>
Irregular size cubes and some cloudy	<p>Some jets plugged</p> <p>Shortage of water</p> <p>Unit not level</p>	<p>Clean jets.</p> <p>See Shortage of Water</p> <p>Water overflowing air vent holes on low side burning cubes. Level as required.</p>
Cubes too large	<p>Cube size control turned too cold</p>	<p>Turn setting on cube size control dial towards warmer</p>
Decreased ice capacity	<p>Inefficient compressor</p> <p>Leaky water valve</p> <p>High head pressure</p> <p>Non-condensable gas in the system:</p> <p>Poor Air circulation or excessively hot location</p> <p>Overcharge of refrigerant</p> <p>Partially restricted cap tube</p>	<p>Replace .</p> <p>Replace or repair.</p> <p>Dirty condenser. Clean. Bad fan motor. Replace.</p> <p>purge the system.</p> <p>relocate the unit, or provide for ventilation by cutting openings;</p> <p>Correct the charge. Purge off slowly. Purge &amp; replace charge and drier</p>
Hole washed inside cube	<p>Water over the top of the cube cups during harvest</p>	<p>Level unit.</p>

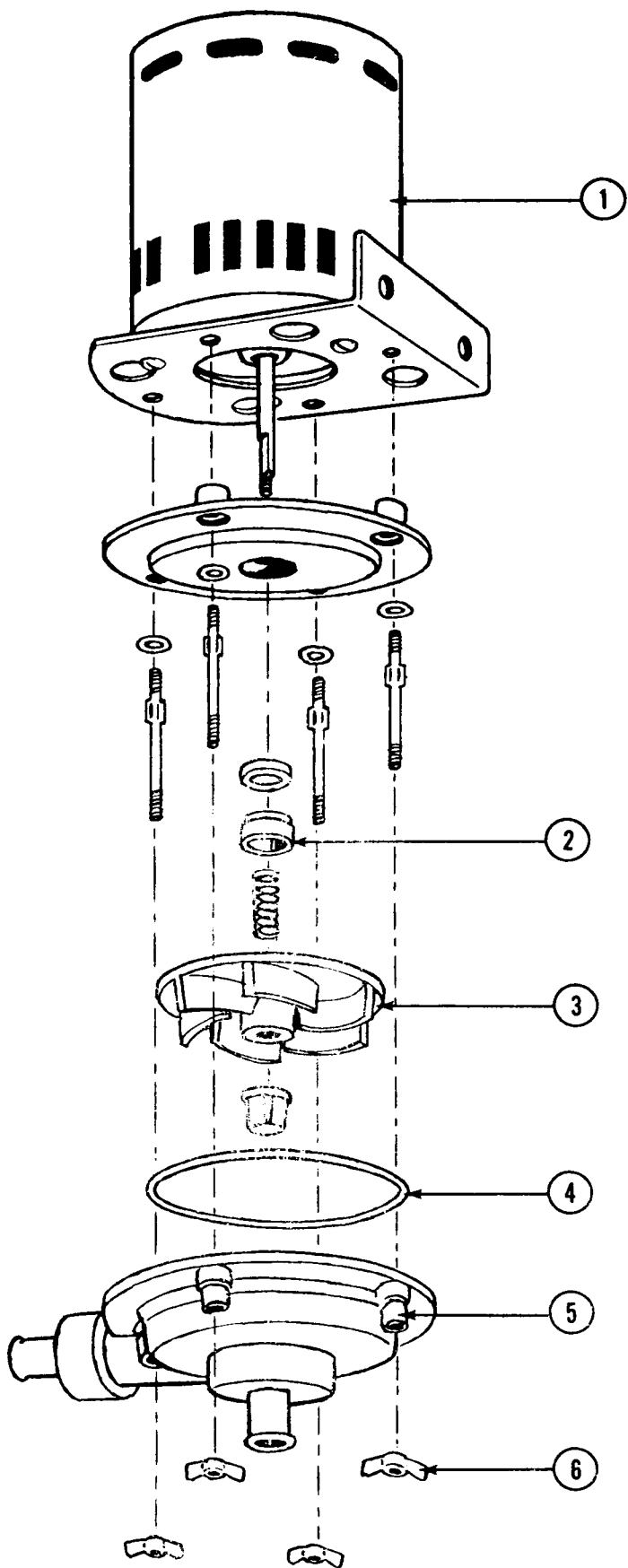

SUMP PUMP ASSEMBLY  
PART NO. 12-1532-1B

<u>ITEM NO.</u>	<u>PART NO.</u>	<u>NAME</u>
1.	12-1532-51	Motor only
2.	12-1532-57	Water Seal
3.	12-1532-58	Impeller
4.	12-1532-60	O-Ring
5.	12-1532-61	Outlet Housing
6.	12-1532-62	Wing Nuts

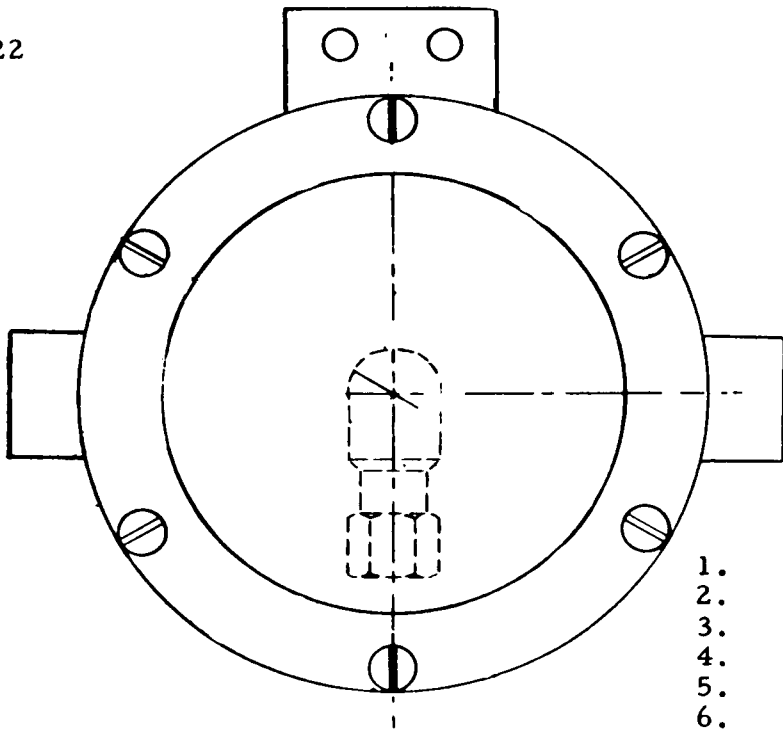

WATER VALVE ASSEMBLY  
A-19722-1

- |     |           |                   |
|-----|-----------|-------------------|
| 1.  | 13-617-2  | O-Ring            |
| 2.  | A-17937   | Valve Cap Bottom  |
| 3.  | 2-1545    | Spring            |
| 4.  | 13-617-1  | O-Ring            |
| 5.  | A-17942   | Lower Plunger Rod |
| 6.  | 3-1403-6  | Screws (6)        |
| 7.  | A-18192   | Valve Top Cover   |
| 8.  | 3-1403-27 | Screw             |
| 9.  | A-17941   | Upper Plunger     |
| 10. | 13-606    | Rubber Diaphragm  |
| 11. | A-18312   | Diaphragm Cover   |
| 12. | A-17947   | Valve Body        |

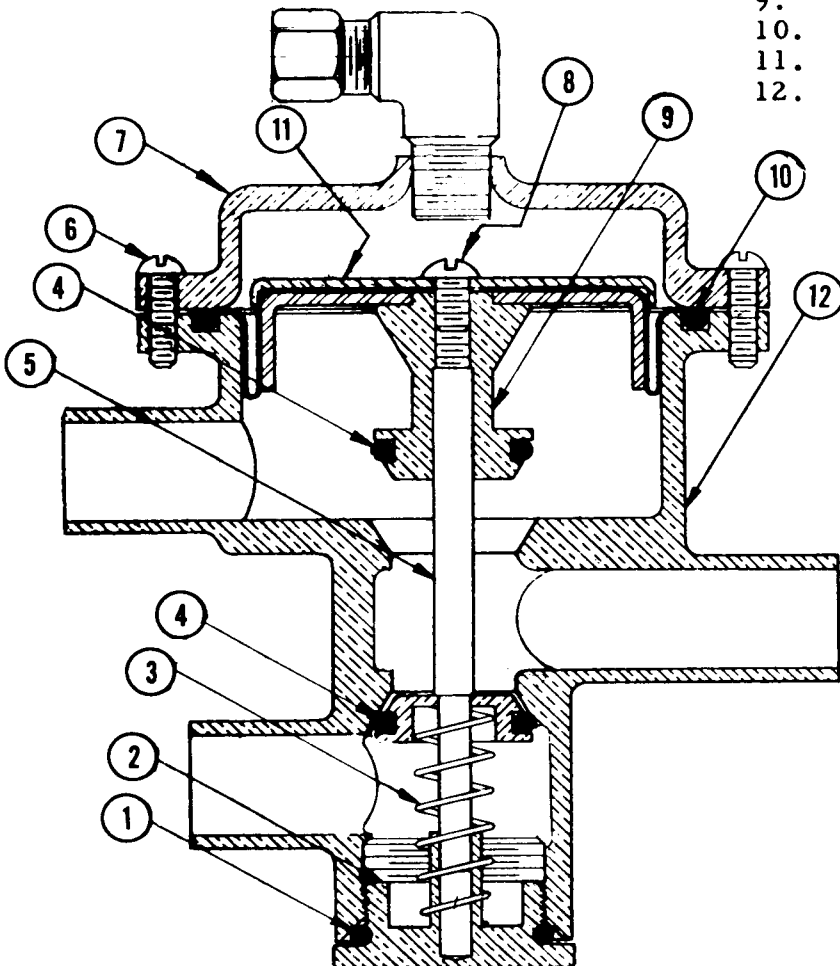

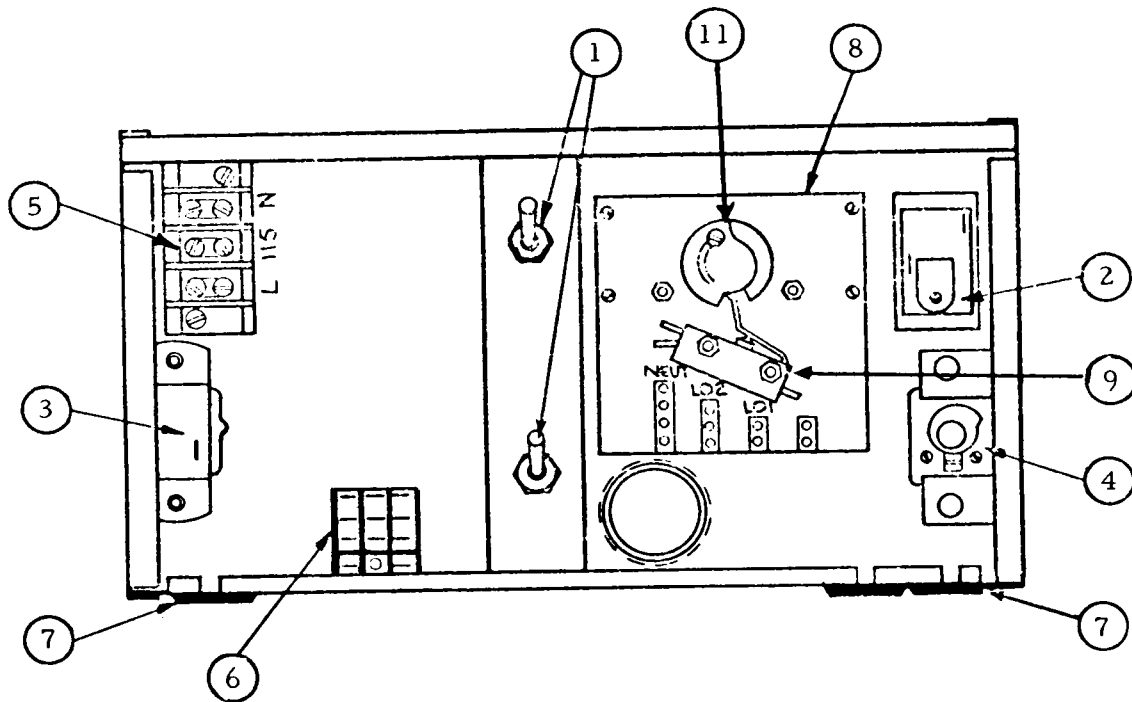

CONTROL BOX ASSEMBLY

ITEM No.	PART NO.	NAME
1.	12-426-1	Switches
2.	11-352	Head Pressure Control - Air Cooled Only
2.	11-397	High Head Pressure Control- Water Cooled Only
3.	11-353	Bin Control
4.	11-351	Cube Size Control
5.	12-813	Terminal Block
6.	12-1645	Relay
7.	13-124	Grommets
8.	A-21038-1	Timer Assy.
9.	12-1480	Timer Micro Switch
*10.	12-1478-1	Timer Motor Only
11.	2-1651	Cam Assy.

\* Not Shown



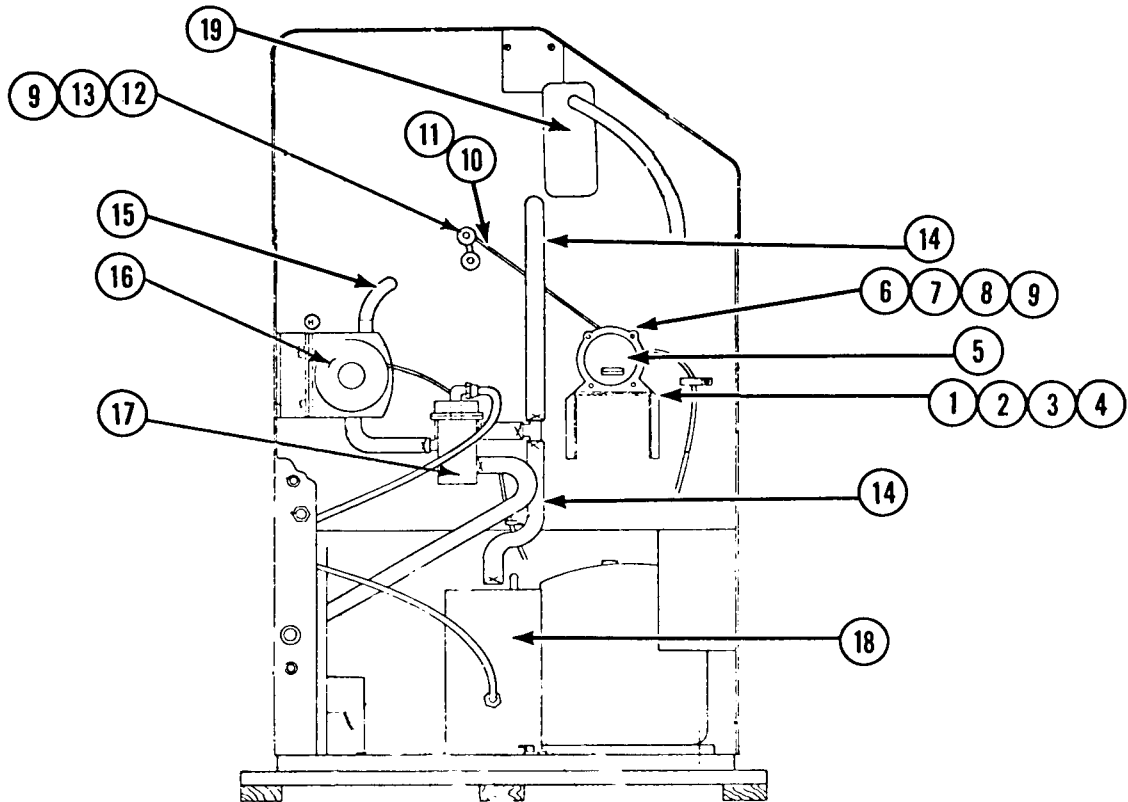

CABINET VIEW - LEFT SIDE

ITEM NO.	PART NO.	NAME
1.	3-1403-28	Machine Screw
2.	3-1406-6	Nut
3.	3-1407-4	Washer
4.	3-1417-5	Lock Washer
5.	12-1346-1	Drive Motor
6.	S-7128	Driven Arm
7.	A-7033	Bearing
8.	S-7558	Bearing Clip
9.	3-431	Set Screw
10.	S-7132	Linkage Rod
11.	A-6726	Linkage Complete w/arms
12.	A-6462	Driven Arm
13.	S-7130	Collar
14.	13-674-6	Tggon Tubing per ft.
15.	13-674-9	Tggon Tubing per ft.
16.	12-1532-1B	Water Pump
17.	A-19722	Water Valve
18.	A19026	Defrost Water Tank
19.	A-20098	Freezer and Suction Line Ass'y.

# SM105J COMPLETE UNIT

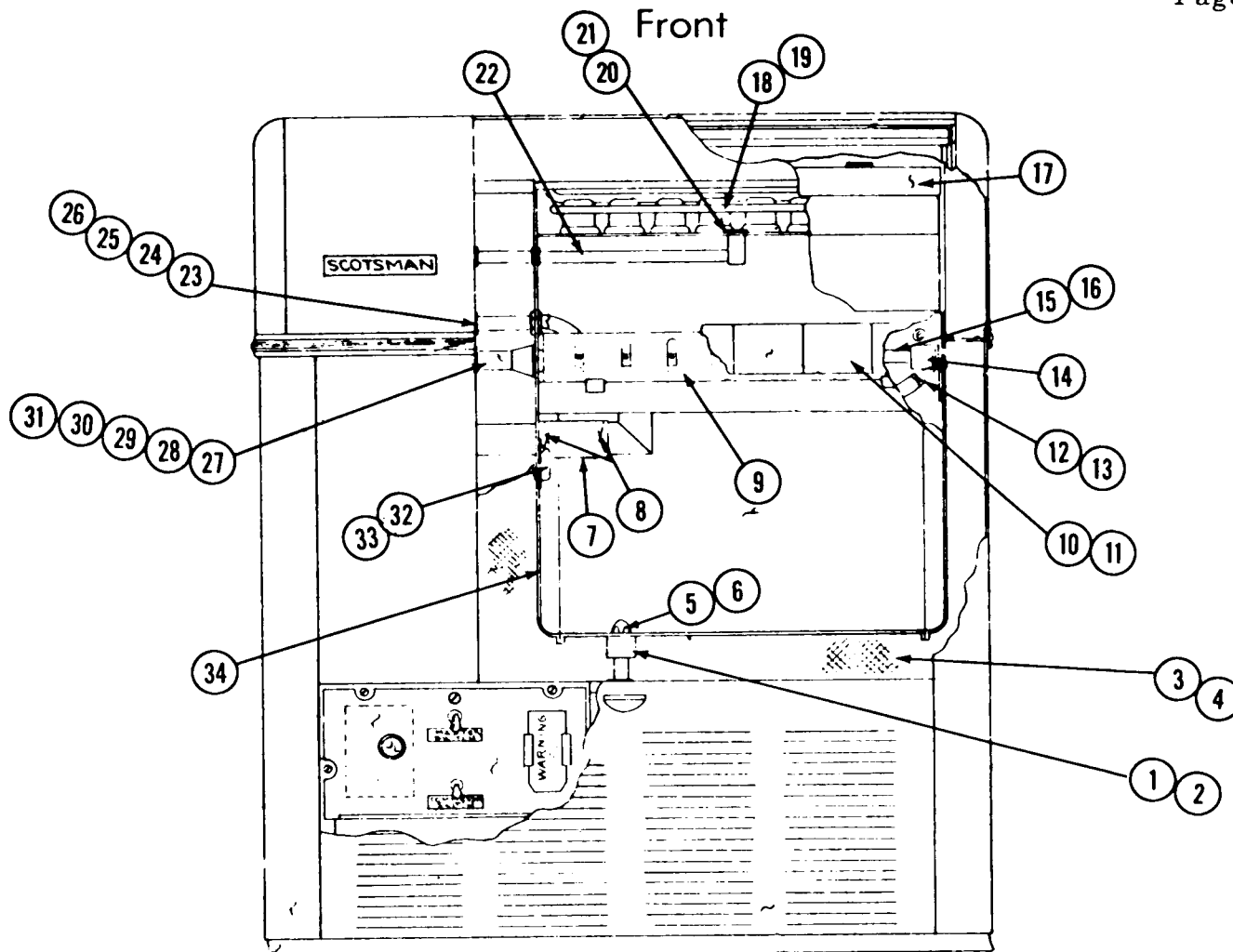

ITEM NO.	PART NO.	NAME	ITEM NO.	PART NO.	NAME
1.	A-18102	Storage Drain Fitting	18.	A-20098	Freezer Suction Line Assy.
2.	2-530	"O" Ring	19.	13-638	Rubber Cupholder
3.	A-15721-1	Insulation Bottom	20.	S-7434	Adapter
4.	A-16246	Insulation Layout	21.	3-1409-3	Fiber Washer
5.	A-18090	Drain Fitting (Male)	22.	A-16437	Inlet Tube
6.	A-6448	Drain Strainer	23.	A-16970	Inlet Tube
7.	5-170-2	Tygon Hose	24.	2-541	"O" Ring
8.	2-537-1	Clamps (2 required)	25.	S-9965	"O" Ring Nut
9.	A-20099	Cube Chute	26.	13-125	Grommet
10.	A-16465	Curtain Ass'y	27.	S-8887	Drive Bearing Support
11.	3-727	Thumb Screws (2)	28.	S-7639	Drive Journal Ass'y
12.	2-1338-2	Clamp	29.	S-7635	Nut
13.	13-674-5	Tygon Tube	30.	3-1409-8	Fiber Washer
14.	A-16963	End Bearing	31.	13-169	Grommet
15.	A-20094	Sprayer Tube	32.	A-19555	Bulb Cover
16.	2-1803-1	Jets	33.	13-590	Bulb Gasket
17.	2-1489	Plastic Insul. Cover	34.	A-18889	Storage & Resv. Assy.

SM105J CASE AND HOOD ASSY.

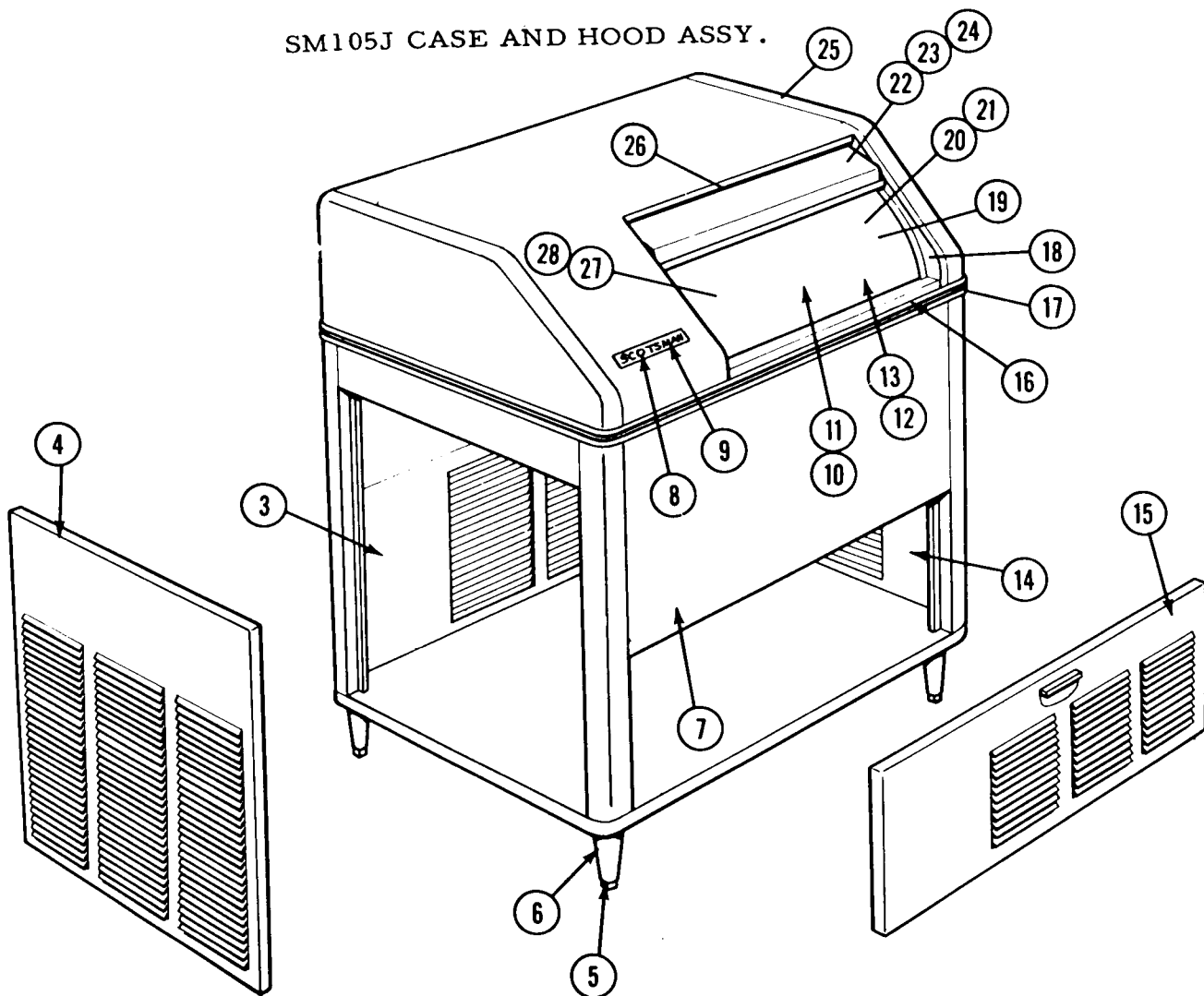

ITEM NO.	PART NO.		NAME
	GRAY	S.S.	
1.	2-530		"O" Ring Drain*
2.	A-6448		Drain Strainer*
3.	A-16563	A-16563-2	Back Door
4.	S-9405	S-9405-S	Left Door
5.	8-522	8-522-1	Leg Leveler
6.	A-15803	A-15803-1	Leg
7.	A-18842	A-18842-1	Case Assy
8.	15-156		Emblem
9.	3-271		Speed Nuts*
10.	A-18102		Storage Drain Assy*
11.	A-18090		Drain Fitting Male*
14.	A-16561	A-16561-2	Right Door
15.	A-15789	A-15789-2	Front Door
16.	15-324		Plastic Insert (per foot)
17.	A-6510		Moulding Strip, Front
18.	A-16208		Door Track
19.	A-18889		Storage Bin Assy*
20.	A-19555		Bulb Cover*
21.	13-590		Bulb Gasket*
22.	2-1735	A-15559	Sliding Door
23.	3-640		Door Slides (Door)
24.	3-1195		Door Slides (Hood)
25.	A-19238	A-19238-1	Hood Assy
26.	2-1736		Door Lanyard * Not Shown

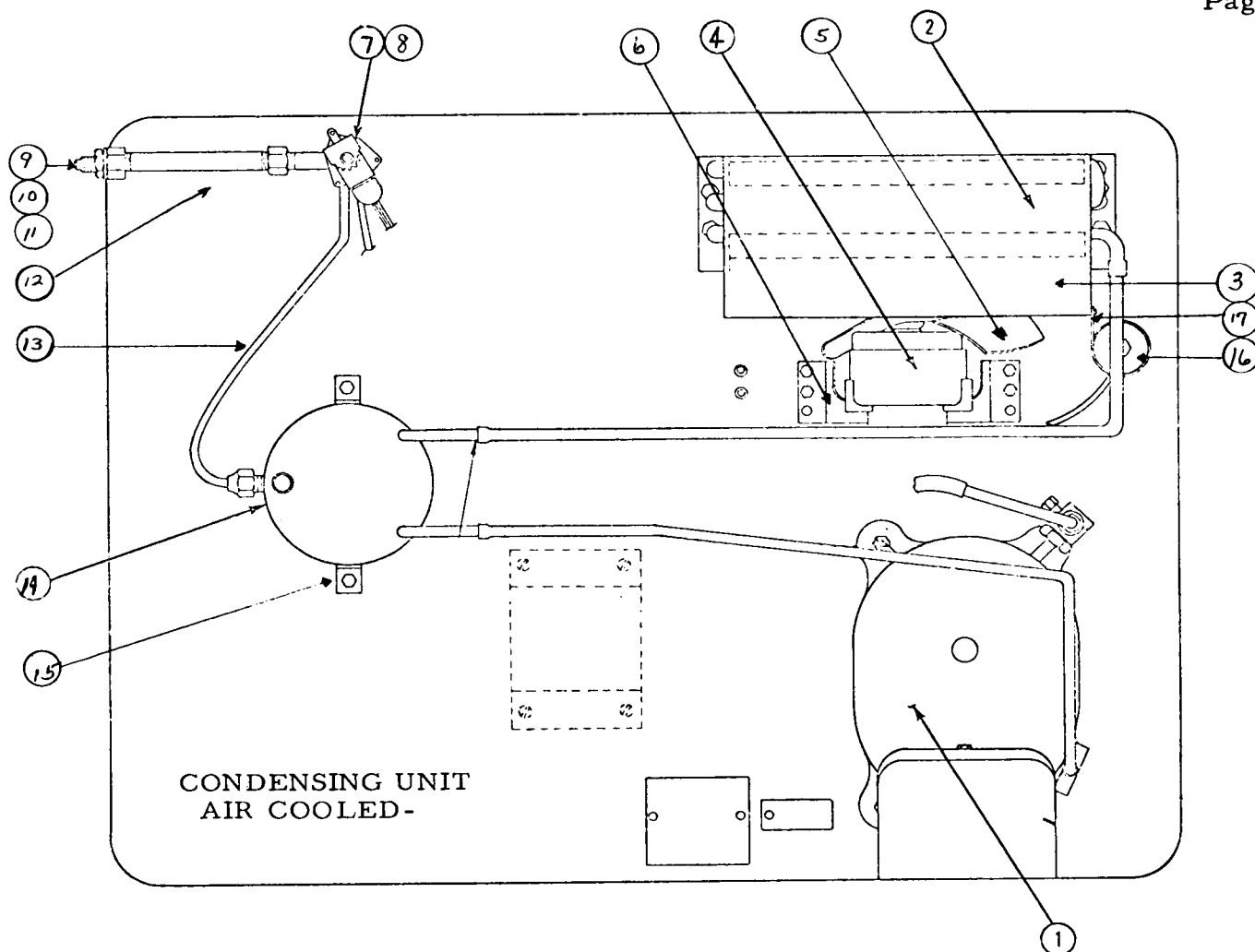

ITEM NO.	PART NO.	NAME
1.	18-2201-1	Motor Compressor 115/60/1
	18-2201-25	Klixon (overload)*
	18-2201-26	Compressor Relay*
	18-2201-29	Start Capacitor*
2.	18-234	Condenser
3.	A-18229	Condenser Shroud
4.	12-1575-1	Fan Motor
	12-1573-8	Lead Wire (Fan Motor)*
5.	18-231	Fan Blade
6.	18-422	Fan Motor Bracket
7.	12-1434-1	Water Solenoid Valve
8.	A-19788-4	Water Flow Control*
9.	A-19239	Inlet Water Fitting
10.	16-526	Brass Nipple,
11.	16-540	Coupling
12.	A-18696	Inlet Water Assy Complete
13.	5-397-1	Nylon Water Line per ft.
14.	A-19026	Defrost Water Tank
15.	A-1-233	Water Tank Bracket
16.	2-350	Drier
17.	A-19386	Drier Brace

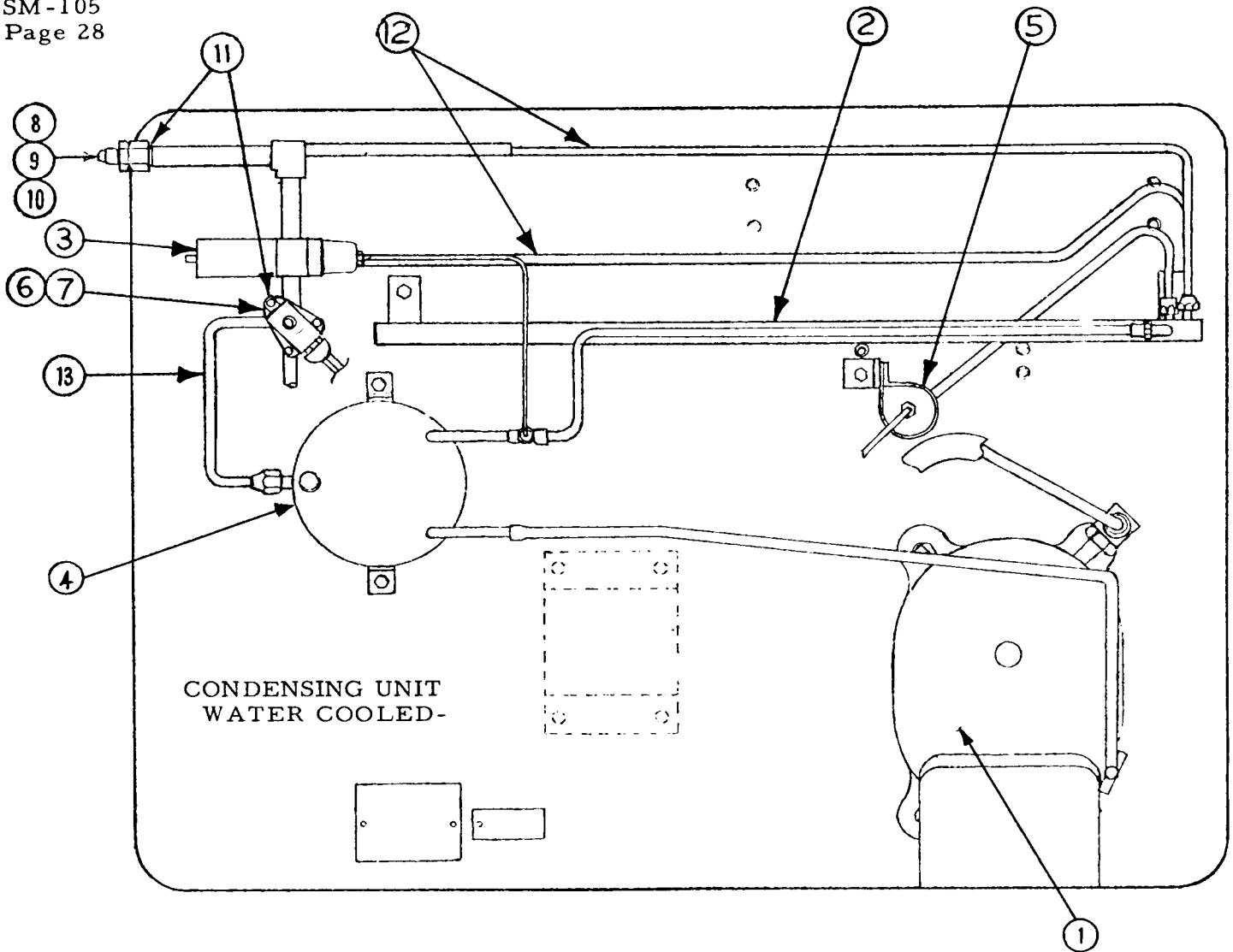

ITEM NO.	PART NO.	NAME
1.	18-2201-1	Motor Compressor 115/60/1
	18-2201-25	Klixon (overload)*
	18-2201-26	Compressor Relay*
	18-2201-29	Start Capacitor
2.	18-368	Condenser
3.	11-198	Water Regulator Valve
4.	A-19026	Defrost Water Tank
5.	2-350	Drier
	A-19386	Drier Brace
6.	12-1434-1	Water Solenoid Valve
7.	A-19788-4	Water Flow Control*
8.	A-19239	Inlet Water Fitting
9.	16-527	Brass Nipple
10.	16-537	Brass Tee
11.	A-18696-1	Inlet Water Assy Complete
12.	5-397-2	Nylon Water Line per ft. - 3/8"
13.	5-397-1	Nylon Water Line per ft. - 1/4"

\* Not Shown

### COMPLETE DRIVE LINKAGE

Part No. A-6726

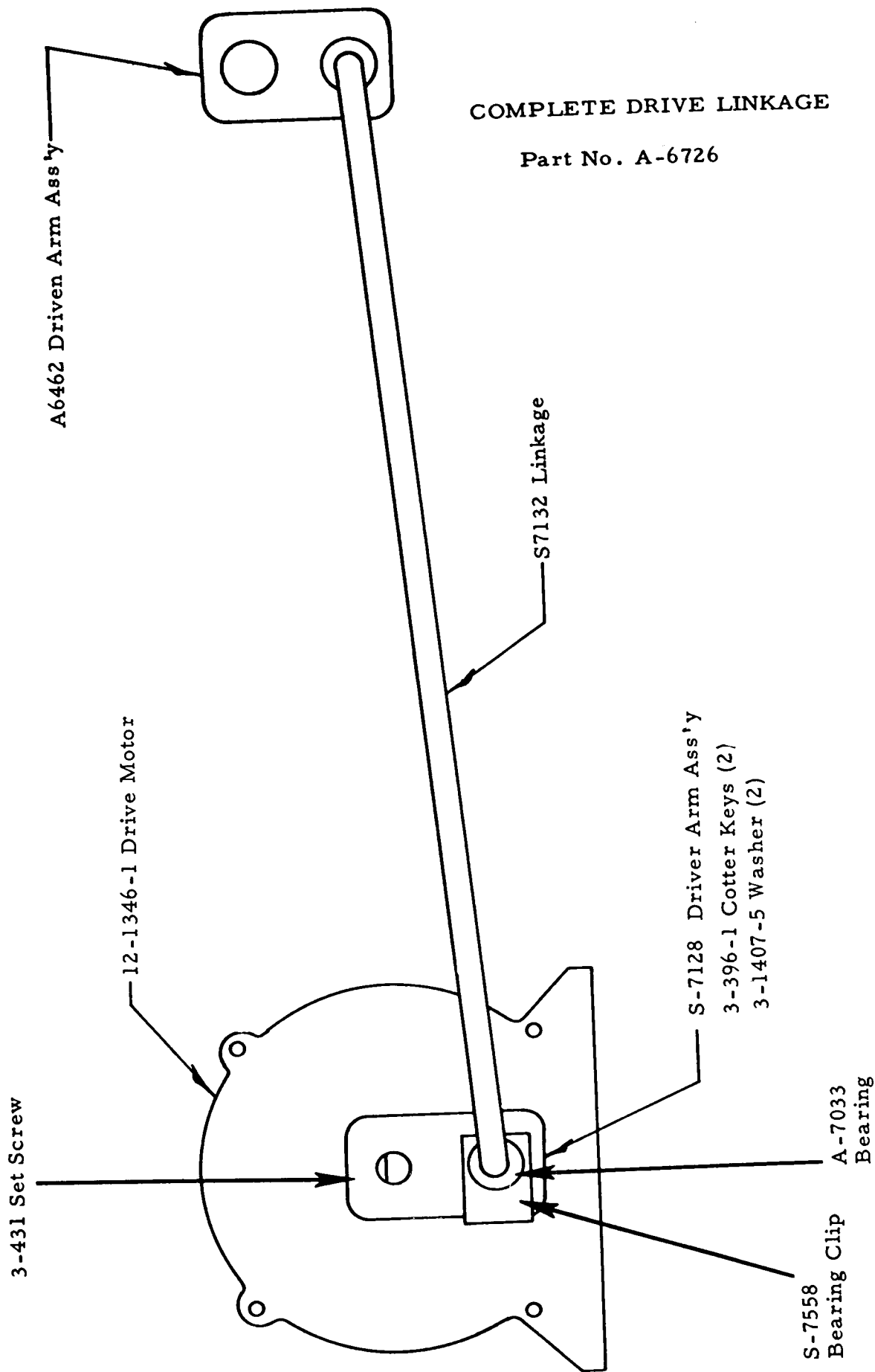

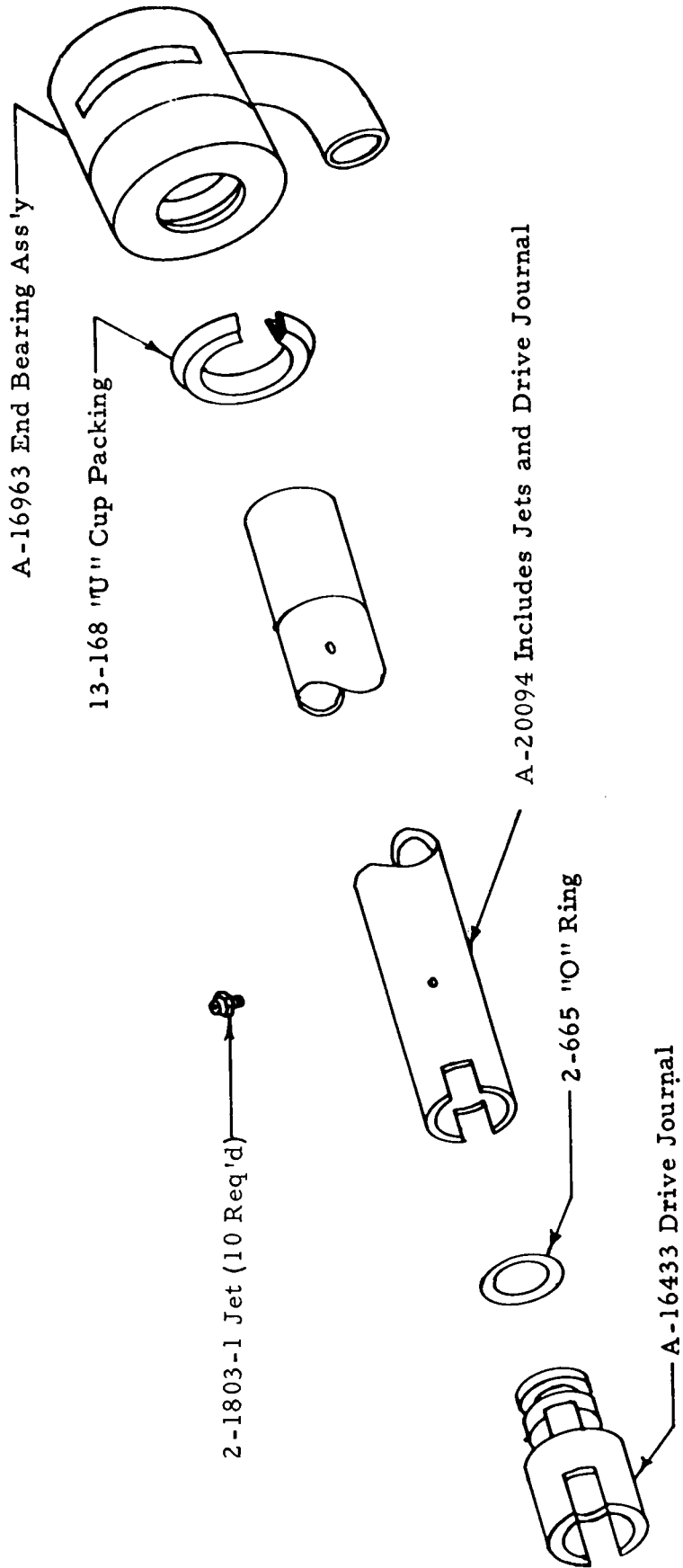

SPRAYER TUBE ASSEMBLY

FUNCTIONAL PARTS  
DESCRIPTION

- 11-352 Fan cycle - head pressure control  
Robert Shaw #A P 20-1066  
120# 140# Range  
Automatic reset - SPST Nonadjustable
- 11-353 Bin Thermostat  
Cutler Hammer #9530 N 213  
Cut Off 35° cut in 39°  
Adjustable calibrate for altitude over 2,000 ft.
- 11-357 High pressure Cut off - Water cooled models  
Robert Shaw #A P 21-2048  
Control opens 190# P.S.I.  
Manual re-set - Adjustable
- 11-351 Cube size thermostat  
Rance All-387  
Reverse acting, closes on temperature  
Decrease - Has adjustment dial
- 12-1645 Relay 115/60/1  
Ameco or Potter Bumfield  
2 P.D.T.  
By passes Thermostat  
during freeze cycle.
- 18-699-3 Water cooled condenser W.C. models only  
Packless #QVWC-37  
3/4 H.P. rating - upright tank type
- 12-1532-1B Water recirculating, sump pump  
Hartell Inc.  
3000 RPM - shaded pole, thermally  
protected motor - 1/25 H.P. 115/60/1
- 18-2201-1 Motor compressor 115/60/1  
Copeland refrigeration - Copelaweld RSF-0050-1AA  
2 Pole, 3500 RPM Hermetic for use with refrigerant  
R-12
- A-21038-1 Finishing Clock or Timer  
Manufactured by Queen Products Div.  
2-1651 Knob cam assembly  
12-1480 Micro switch.
- 12-1434-1 Water inlet solenoid  
Detroit Controls Corp. #S-30-A  
115/60/1 coil - Nylon body  
1/4" MPT inlet & outlet No flow control.  
Also American Standard Control #SSV-20206



## SERVICE - COMPLETE UNIT

ALL STEPS LISTED BELOW SHOULD ONLY BE STARTED WHEN WATER AND ELECTRICAL SUPPLY ARE OFF TO PREVENT ACCIDENTS.

To remove cabinet top or hood.

1. Remove two back end screws in rear moulding strip.
2. Pull out black insert tape concealing screws.
3. Remove balance of screws in moulding strips.
4. Lift hood straight up.

To remove Sump Pump.

1. Remove left side service panel.
2. Disconnect hose clamps and hoses on pump ports.
3. Remove electrical lead to control box.
4. Remove 2 screws in pump mounting bracket.

To remove Agitator Motor on SM105

1. Remove left side service panel
2. Disconnect wires at the control box terminal board.
3. Loosen the Allen set screw on driver crank arm and remove the drive arm.
4. Remove the four hold-down screws and remove the motor.

To remove the jet tube assembly on Model SM105

1. Remove the plastic curtain assembly.
2. Remove the cube rack.
3. Lift the right end of the jet tube straight up and slide the other end out of the driving slot.

To remove Three Way Water Valve

1. Remove left side service door.
2. Remove all hose clamps to water valve.
3. Remove upper water line connection to elbow on top valve housing.
4. Loosen two nut and bolt assemblies holding valve to mounting bracket. Valve now drops free.
5. Replace in reverse of above.

To replace Storage Bin Door

1. Lift door up and slide back as you normally would to remove ice from bin.
2. Remove screw at center rear edge of door where it is attached to lanyard.
3. Pull door straight out.
4. Install repaired or new door in reverse of step number 2 above.

## MAINTENANCE INSTRUCTION FOR SCOTSMAN SUPER CUBERS

THE FOLLOWING MAINTENANCE MUST BE ACCOMPLISHED TWO (2) TIMES PER YEAR ON ALL SCOTSMAN SUPER CUBERS. CALL YOUR AUTHORIZED SCOTSMAN SERVICE DEPARTMENT.

1. Clean air-cooled condenser; This is to be done frequently with the machine shut off.
2. Clean water system and evaporator, sump tank and screen, using Scotsman Ice Machine Cleaner or equivalent.
3. Remove jet tube and manually clean jets by unscrewing jets.
4. Check curtain assembly.
5. Tighten all electrical connections.
6. Tighten all bolts.
7. Check water supply. Check water pressure flow through flow control. Clean water strainer.
8. Oil jet tubes drive motor three(3) places. Use SAE 20 oil - 3 oil cups.
9. Oil Condenser fan motor. Punch sealed cap or remove screws where possible.
10. Check for refrigeration leaks with halide torch.
11. Check for water leaks. Tighten drain line connections.
12. Check size and condition of cubes. Adjust as required. See Service Analysis
13. Section.  
Check bin thermostat setting. Factory set at 35° out, 39° in.

## CLEANING INSTRUCTIONS FOR SCOTSMAN ICE MACHINES MODELS MM110J, SC100J and SM105J

1. Remove front access door.
2. Locate control box with time clock knob protruding through cover.
3. Start unit through a harvest cycle manually. This may be done by turning time clock knob clockwise until the snap of the timer microswitch is heard.
4. Let unit finish cube harvest cycle and start into freezing cycle. This will be approximately 5 minutes after Step #3 has been completed. At this time turn the compressor switch off, the lower of the two switches in the control box.
5. Locate the sump reservoir which is in the storage bin area and directly behind the ice discharge chute. This discharge chute is covered by a series of white plastic curtains which are free to swing out into the storage bin. Pour 4 ounces (half bottle) of "Scotsman Ice Machine Cleaner" into the sump reservoir.
6. Locate insulation panel which is directly above platen. Lift insulation panel, pour the remaining 4 ounces of "Scotsman Ice Machine Cleaner" into platen.
7. Let unit operate normally for 10 to 15 minutes into the freezing cycle. No ice will be made because the motor compressor is not in operation.
8. At the end of this time put the unit through 2 or 3 harvest cycles manually to allow fresh make up water to clean out remaining solution. Each time waiting approximately 5 minutes after the loud snap until the next harvest cycle is done manually.
9. Turn the compressor switch back on.
10. Check each new batch of cubes until they are clear and until acid taste has been removed from cubes.
11. Put hot water in storage bin to melt the cubes and thereby clean the drains with the same solution that has just cleaned the unit.
12. Use a damp cloth to wipe off curtains and inside of storage bin.
13. Replace all access doors.
14. Unit is now ready for continued automatic operation.

PARTS LIST SM105

CABINET PARTS

		<u>S. S. Finish</u>
2-1736	Sliding Door Lanyard	
A-19238	Case hood assembly, less doors	A-19238-1
A-16208	Door slide track	
15-156	Emblem	
A-6509	Moulding strip - rear	
A-6510	Moulding strip - front	
A-15789	Cabinet front service	A-15789-2
A-16561	Cabinet right side service door	A-1656-2
A-16563	Cabinet rear service door	A-16563-2
2-1735	Sliding Door	A-15559
S-9405	Cabinet left side service door	S-9405-S

CONTROL BOX - ELECTRICAL COMPONENTS

12-813	Terminal Block
A-21038-1	Timer Assembly
12-1480	Timer Micro-switch
11-351	Cube size control
12-426-1	On-Off switches (2)
11-353	Bin thermostat
12-1645	Complete cube relay
11-352	Fan cycle control A.C.
11-357	H. Pressure control

CONDENSING UNITS AND REFRIGERANT CIRCUIT

	AIR-COOLED	WATER-COOLED
Freezer Cup and Platen only	A-20097	Same
Freezer and H X assembly complete	A-20098	Same
Drier - Refrigerant	2-350	Same
Motor compressor 115/60/1	18-2201-1	Same
Relay	18-2201-26	Same
Starting capacitor	18-2201-29	Same
Fan motor	18-1575-1	None
Fan blade	18-321	None
Condenser	18-334	18-699-3
Shroud for condenser	A-18229	
Klixon overload	18-2201-25	Same
Tire type valve cap	16-563	Same
Tire type valve core	16-560	Same
Rubber cube cup holder	S-9251	Same
Plastic curtain rod assembly	A-16465	Same
Water Regulating Valve	None	11-198

PARTS LIST - SC-100J

4. HOT WATER CONDENSER TANK

A-19026 Hot water tank complete - Air & Water cooled.

5. WATER VALVE

A-19722 Complete Valve  
13-617-2 O-Ring  
A-17937 Valve Cap Bottom  
2-1545 Compression Spring  
13-617-1 O-Ring  
A-17942 Lower Plunger  
3-1403-6 Cover Screws (6)  
A-18192 Valve Cover  
A-17941 Upper Plunger  
13-606 Rubber Diaphragm  
A-18312 Diaphragm Cover  
A-17947 Valve Body

6. WATER CIRCUIT

12-1434-1 Inlet water solenoid  
16-162 Inlet water strainer  
A-19788-4 Inlet water flow control  
12-1532-1B Sump pump assembly  
A-20094 Sprayer tube assembly  
2-1803-1 Sprayer tube jet only

7. DRIVE MOTOR AND LINKAGE

12-1346-1 Drive Motor  
A-6726 Drive Linkage assembly  
A-6462 Driver Arm Assembly  
S-7132 Linkage Rod  
S-7128 Driver Arm Assembly  
S-8887 Drive Bearing Support  
S-7639 Driving Journal

8. STORAGE BIN AND COMPONENTS

2-530 "O" Ring  
A-18090 Storage Bin Drain Assembly, Male  
A-6448 Drain, strainer  
A-18102 Storage Bin Drain Ass'y, Female  
A-19555 Bin Thermostat Bulb Cover  
13-590 Bin Thermostat Bulb Gasket  
A-20099 Cube Chute  
A-16465 Curtain Assembly

9. MISCELLANEOUS

2-540 Ice Scoop  
15-324 Plastic trim insert-per ft.  
1-657 Packing crate  
12-1532-51 Sump Pump motor only  
19-343 Scotsman Ice Machine Cleaner  
5-397-2 Nylon tube (per foot) 3/8"  
5-379-1 Nylon tube (per foot) 1/4"