

TABLE OF CONTENTS
F5-2 SECTION

	Page
FORWARD	
WARRANTY	
GENERAL	
Specifications.....	1
SPECIFICATIONS	
Dimensions SF-2F.....	2
Dimensions SF-2WSF.....	3
Capacity	4
INSTALLATION	
Uncrating.....	5
Location	6
Erection, Stands, Chutes	7
Plumbing.....	8
Electrical	8
Instructions.....	9
SERVICE	
Starting Machine.....	10
Refrigerant Charge.....	11
Water Level.....	11
Electrical System.....	12
Controls.....	12-13
Refrigeration Cycle.....	14
Water Cycle.....	15
Cabinet Water Schematic.....	16
Chassis.....	17
Freezer Assembly	18-19
Wiring Diagrams	20-21
Service Analysis Chart.....	22-24
Winsmith Gear Reducer.....	25
MAINTENANCE INSTRUCTIONS	26
CHANGES AND MODIFICATIONS	27-28
PARTS LIST.....	29-32
OBSOLETE FREEZERS.....	33-34

SPECIFICATIONS

SCOTSMAN SF-2 Super Flaker is designed for restaurants, super markets, bakeries, dairies, fish markets, hospitals, cafeterias, poultry stores, soda fountains, etc. and will deliver a continuous flow of ice flakes at a capacity up to 650 lbs. per day.

ATTRACTIVE COMPACT CABINET. Silver grey hammerloid finish with chrome trim, rounded corners, and removable panels for easy access to mechanical parts.

SEALED REFRIGERATION SYSTEM. Provides quiet, efficient operation of the machine. Compressor motor is spring mounted and the worm motor is rubber mounted for quiet operation.

HOW IT WORKS. Water in the constant level float reservoir is fed to the bottom end of a freezing cylinder and turns to ice on the inside of this cylinder. The stainless steel auger inside of this evaporator is driven by a motor through a V belt and gear reduction drive. Ice is carried upward by the action of this auger and extruded past the ice breaker at the top of the cylinder.

A manual switch starts the machine, and from then on ice is produced automatically in small uniform pieces of ice. When the storage bin fills, a thermostat shuts the machine off and causes it to start up again when ice is taken from the storage compartment.

SF-2F CONTINUOUS FLOW

INSTALLATION DIMENSIONS

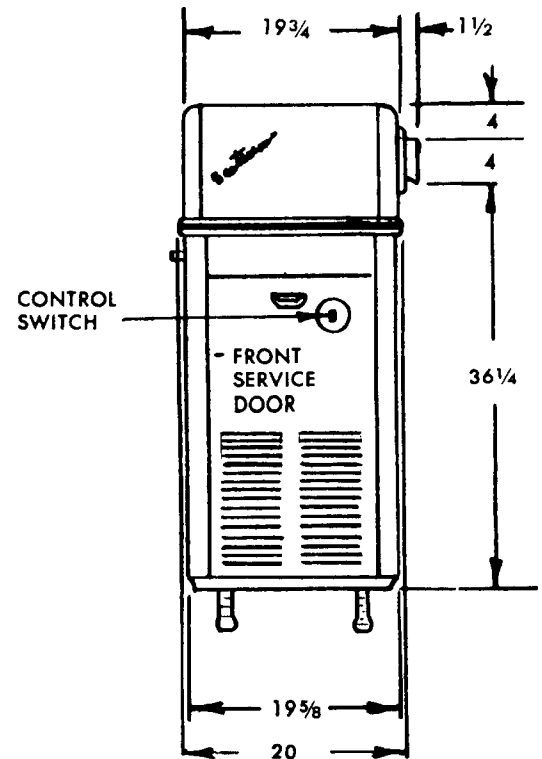
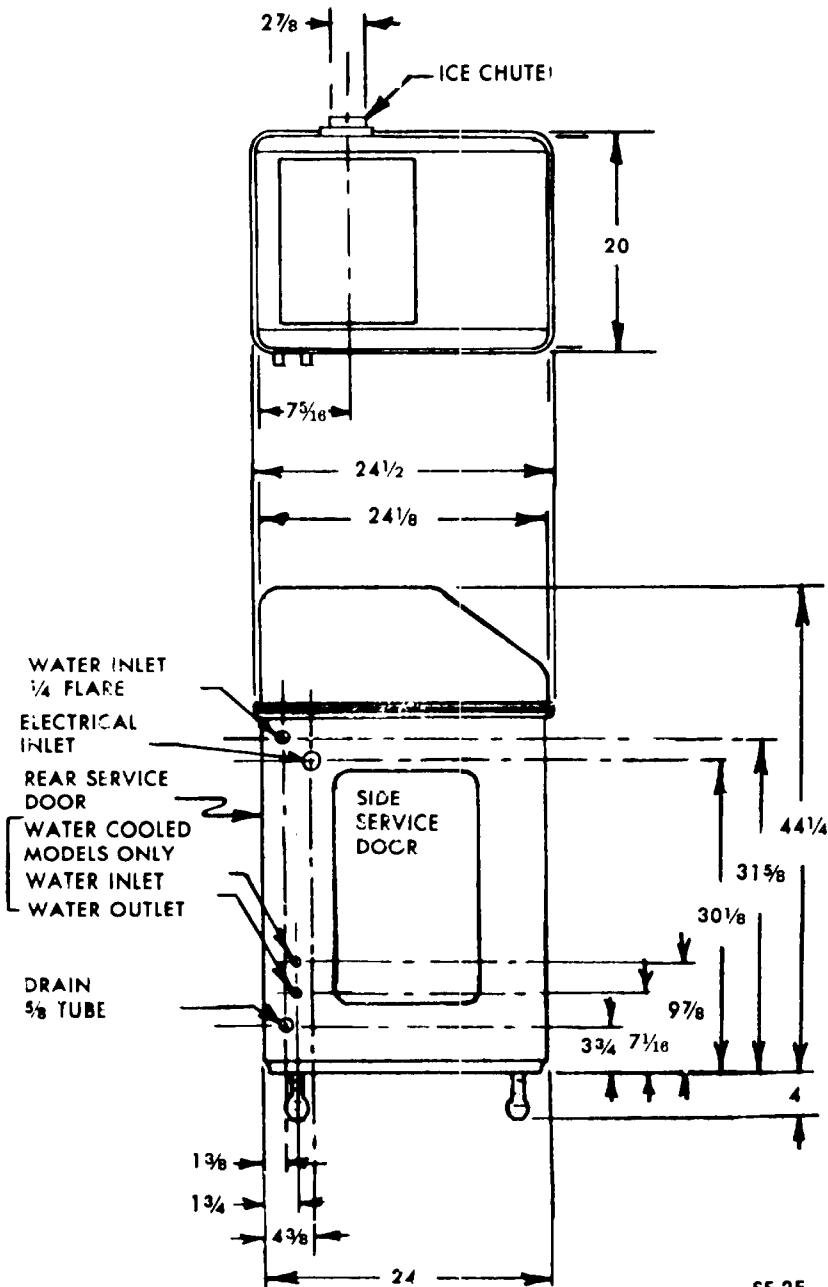
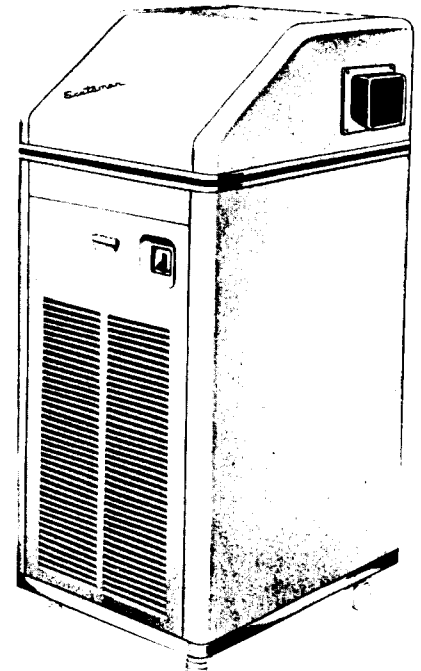

SF-2F

SF-2WSF AUTOMATIC STORAGE

INSTALLATION DIMENSIONS

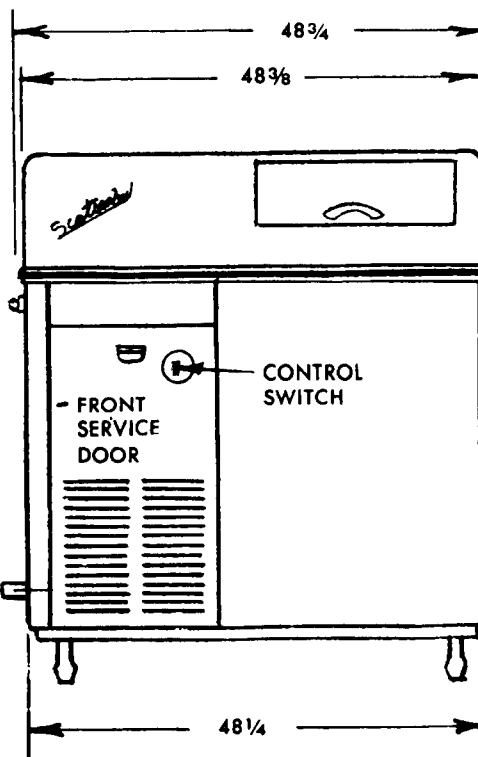
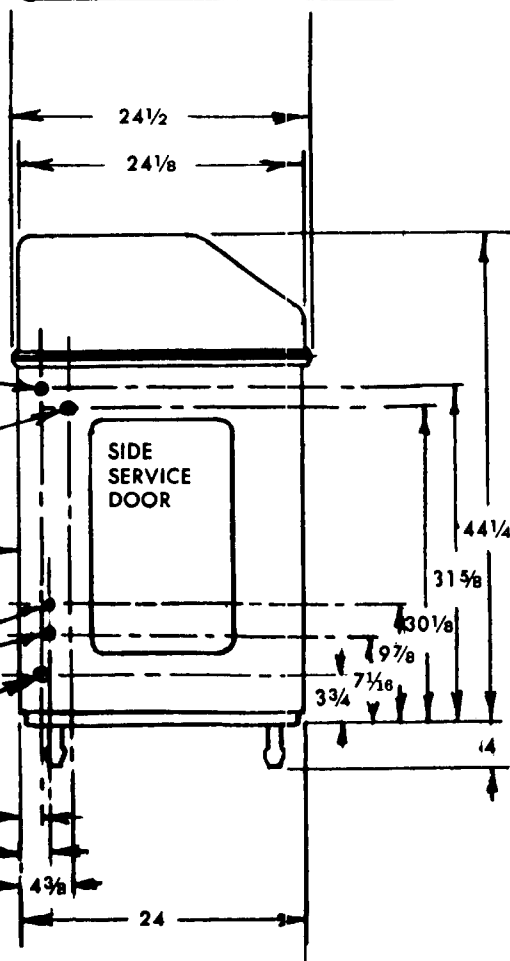
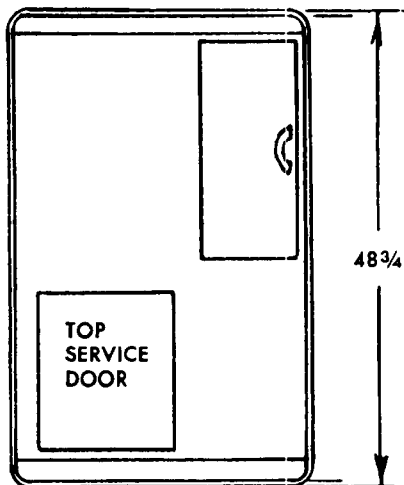
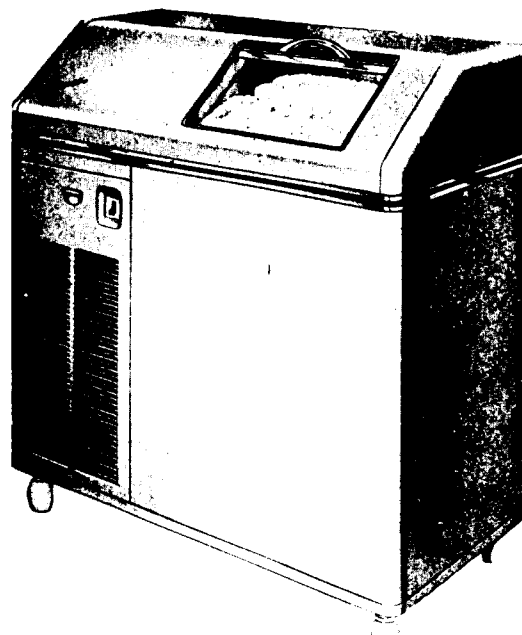

SF2-WSF

ICE MAKING CAPACITY
SF-2F Super Flexers
130 PSI Condensing
on Water Cooled Models

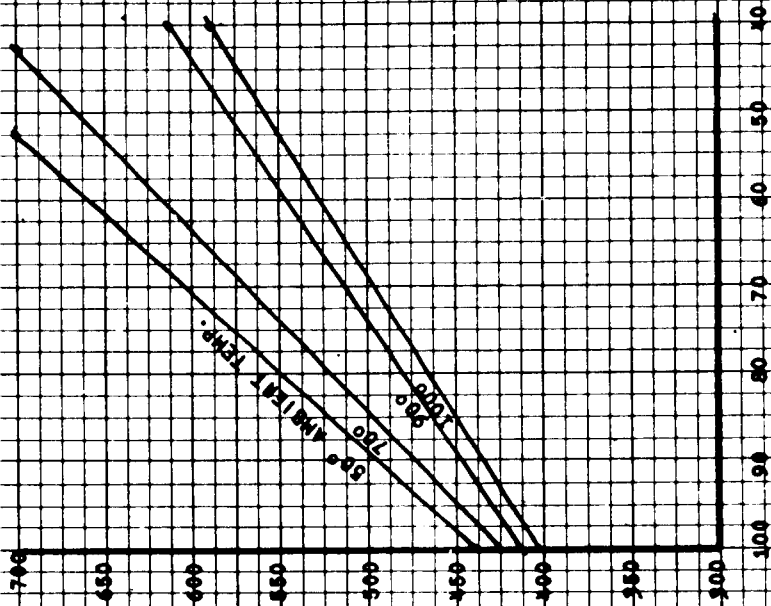

SF-2MF
Water Cooled

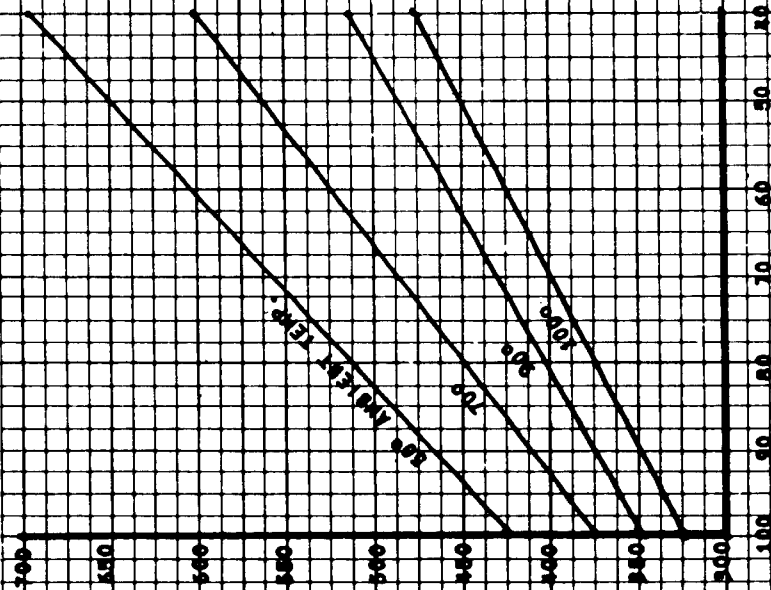

SF-2F
Air Cooled

INSTALLATION

UNCRATING OF MACHINE

The complete machine comes in one crate. After the crate is removed, inspect for concealed damage. When installing the machine, remove the bottom skids by removing all bolts. Then cut all wires holding support packing from refrigerant lines. Then loosen shipping bolts on the compressor. Be sure the compressor is floating free on spring mounts. Remove leg levelers from the carton and install on base as desired. Then check all refrigerant lines for rubbing or touching other surfaces. Also check for possible transportation damage. Check for free movement of ice worm.

PRE-INSTALLATION CLEANING

Before machine is in final location, remove warranty card and other information from machine compartment. Remove top service door, water reservoir cover and packing under float. Then leave cover off for float adjustment after machine is installed.

LOCATION OF THE SUPER FLAKER

Select the location before delivering Super Flaker to the job. The following points should be considered when making selection.

1. Convenience. Place the unit as close as possible to the place of ice consumption.
2. Servicing. Install the machine on continuous flow models so it can be serviced from all three sides except the side containing the ice chute opening. Important to leave 24" access to front (containing on-off switch) and left side on both with storage and continuous flow models.
3. Room Temperature. Minimum - 50 degrees. Maximum - 100 degrees.
4. Continuous Flow Models.
 - A. Bins. Care should be exercised in proper bin selection. Too small a bin will give unsatisfactory performance. A bin should have a minimum of 1/2 of machine's capacity per day, when the machine shuts off on thermostat. Make

INSTALLATION

sure that user's demands are met by proper bin as well as by proper machine selection. Plan relative location of the machine so as to enter the bin as close to the top as possible. Bins should also be higher than their width and length dimensions, so the maximum ice can be stored in the minimum cubic feet of space. A Scotsman bin is designed in this fashion and will be the most convenient to the user. Too large a bin can cause trouble. Excessive melting of ice will occur if the bin is larger than required. Proper bin selection is important to the success of the ice machine installation.

- B. Stands. A Scotsman Machine stand should be used if the machine is located beside the Scotsman bin. In designing the installation, plan for servicing of the machine from front, top, and sides.
- C. Erection. For elevations in excess of four feet or in close quarters, chain falls should be used. For locations under four feet, the use of skid boards and rollers are practical.
- D. Bin Thermostat. Locate the thermostat bulb as high as possible in the bin and still allow the machine to cut off before ice builds up in the chute. If this occurs, ice can stick in the chute keeping the machine off after there is a need for ice production. The capillary can usually enter through the chute opening. Keep the bulb and capillary line away from shovels.
- E. Ice Chutes. If the outlet of the machine is remote from the bin, a chute will be required. Stainless steel is an excellent material for this purpose where its' cost is not prohibitive. Angles or ledges of less than 45° should not be used. Ice will cling to this surface and either melt excessively or jam in the chute. The sharper the drop the better. If straight down, do not insulate, unless necessary.

SPECIFICATIONS

SUPER FLAKER SF-2 SERIES (Storage Type)	MODEL SF-2WSH	MODEL SF-2WWSH	MODEL SF-2WSH-SS	MODEL SF-2WWSH-SS
Daily capacity up to 650 lbs.	X	X	X	X
350 lb. ice storage bin	X	X	X	X
Stainless steel bin	X	X	X	X
Air cooled condenser	X		X	
Water cooled condenser		X		X
Heavy duty 1/2HP. Compressor	X	X	X	X
Standard 115 V, 60 cy, 1 ph, AC—	X	X	X	X
1/4" water inlet SAE Flare	X	X	X	X
3/8" condenser water inlet NPT		X		X
3/8" condensate drain ID				
5/8" bin drain outlet OD	X	X	X	X
3/8" water outlet OD		X		X
Hammerloid grey exterior	X	X		
Stainless steel exterior			X	X
49" height (with legs)	X	X	X	X
43" height (without legs)				
48 1/2" width	X	X	X	X
24 1/2" depth	X	X	X	X
Approximate shipping weight	502	502	502	502

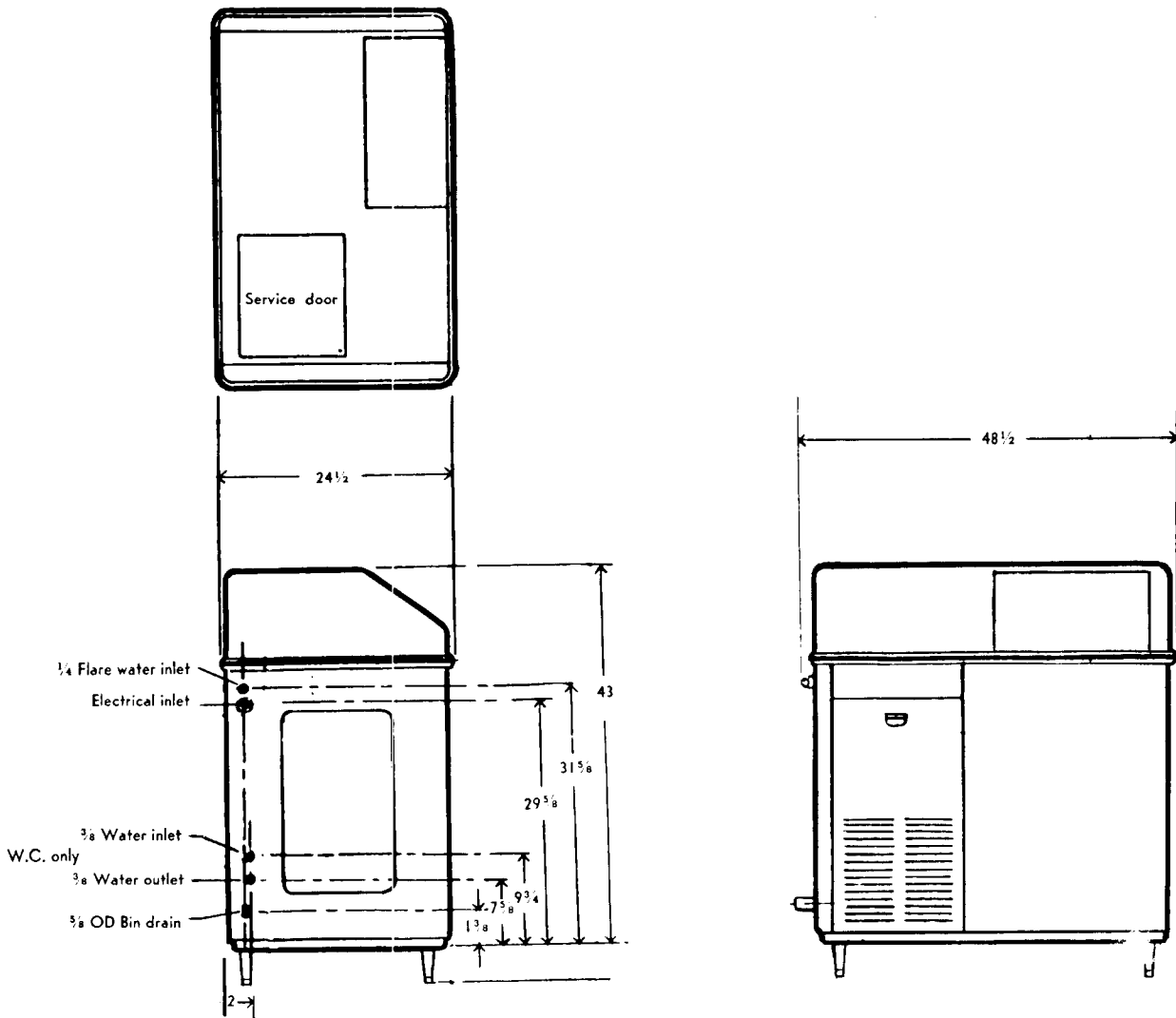

SPECIFICATIONS

SCOTSMAN SF-2 Super Flaker is designed for restaurants, super markets, bakeries, dairies, fish markets, hospitals, cafeterias, poultry stores, soda fountains, etc. and will deliver a continuous flow of ice flakes at a capacity up to 650 lbs. per day.

ATTRACTIVE COMPACT CABINET. Silver grey hammerloid finish with chrome trim, rounded corners, and removable panels for easy access to mechanical parts.

Also available in stainless steel cabinet.

SEALED REFRIGERATION SYSTEM. Provides quiet, efficient operation of the machine. Compressor motor is spring mounted and the worm motor is rubber mounted for quiet operation.

HOW IT WORKS. Water in the constant level float reservoir is fed to the bottom end of a freezing cylinder and turns to ice on the inside of this cylinder. The stainless steel auger inside of this evaporator is driven by a motor through a V belt and gear reduction drive. Ice is carried upward by the action of this auger and extruded past the ice breaker at the top of the cylinder.

A manual switch starts the machine, and from then on ice is produced automatically in small uniform pieces of ice. When the storage bin fills, a thermostat shuts the machine off and causes it to start up again when ice is taken from the storage compartment.

Model No. SF-2H is a continuous flow type machine, and is manually started by an OFF and ON switch located behind the front service door as are the SF-2WSH models. Since the SF-2H does not have its own attached bin, it is necessary to use an auxiliary bin such as the Model SB-500 SCOTSMAN Super Bin for ice storage. A bin thermostat is mounted in each SF-2H continuous flow type machine for the purpose of mounting control bulb from machine to bin.

INSTALLATION

UNCRATING OF MACHINE

The complete machine comes in one crate. After the crate is removed, inspect for concealed damage. When installing the machine, remove the bottom skids by removing all bolts. Then cut all wires holding support packing from refrigerant lines. Then loosen shipping bolts on the compressor. Be sure the compressor is floating free on spring mounts. Remove leg levelers from the carton and install on base as desired. Then check all refrigerant lines for rubbing or touching other surfaces. Also check for possible transportation damage. Check for free movement of ice worm.

PRE-INSTALLATION

Before machine is in final location, remove warranty card and other information from machine compartment. Remove top service door, water reservoir cover and packing under float. Then leave cover off for float adjustment after machine is installed.

LOCATION OF THE SUPER FLAKER

Select the location before delivering Super Flaker to the job. The following points should be considered when making selection.

1. Convenience. Place the unit as close as possible to the place of ice consumption.
2. Servicing. Install the machine on continuous flow models so it can be serviced from all three sides except the side containing the ice chute opening. Important to leave 24" access to front (containing on-off switch) and left side on both with storage and continuous flow models.

INSTALLATION

3. Room Temperature. Minimum - 50 degrees. Maximum - 100 degrees.

4. Continuous Flow Models.

A. Bins. Care should be exercised in proper bin selection. Too small a bin will give unsatisfactory performance. A bin should have a minimum of 1/2 of machine's capacity per day, when the machine shuts off on thermostat. Make sure that user's demands are met by proper bin as well as by proper machine selection.

Plan relative location of the machine so as to enter the bin as close to the top as possible. Bins should also be higher than their width and length dimensions, so the maximum ice can be stored in the minimum cubic feet of space. A Scotsman bin is designed in this fashion and will be the most convenient to the user. Too large a bin can cause trouble. Excessive melting of ice will occur if the bin is larger than required. Proper bin selection is important to the success of the ice machine installation.

B. Stands. A Scotsman Machine stand should be used if the machine is located beside the Scotsman bin. In designing the installation, plan for servicing of the machine from the front, top, and sides.

C. Erection. For elevations in excess of four feet or in close quarters, chain falls should be used. For locations under four feet, the use of skid boards and rollers are practical.

D. Bin Thermostat. Locate the thermostat bulb as high as possible in the bin and still allow the machine to cut off before ice builds up in the chute. If this occurs, ice can stick in the chute keeping the machine off after there is a need for ice production. The capillary can usually enter through the chute opening. Keep the bulb and capillary line away from shovels.

INSTALLATION

E. Ice Chutes. If the outlet of the machine is remote from the bin, a chute will be required. Stainless steel is an excellent material for this purpose where its' cost is not prohibitive. Angles or ledges of less than 45° should not be used. Ice will cling to this surface and either melt excessively or jam in the chute. The sharper the drop the better. If straight down, do not insulate, unless necessary.

WATER SUPPLY

The recommended water supply line is 3/8" OD Copper Tubing for SF-2. connect to cold water supply line with regular plumbing fittings, with a shut-off valve installed in an accessible place between supply line and machine. A water strainer must be installed with the unit and mounted with clean-out plug down. Locate the strainer next to the machine with the arrow in the direction of the flow. Most plumbing codes also call for double check valves in the supply water line, particularly for water cooled models.

The water supply line for water reservoir connects to the 1/4" flare fitting on the machine. On water cooled models connections are made to a 3/8" male pipe nipple inside of the machine compartment for the condensor water. Incoming water goes through the water regulating valve first and then to the water cooled condensor. Observe arrow on water regulating valve. Water supply must be installed to conform with local code. In some cases a licensed plumber and/or a plumbing permit will be required.

DRAIN

The recommended drain from the bin is 5/8" OD Copper Tubing. Must be run to an open trapped and vented drain. If drain is a long run, allow a 1/4" pitch per foot. Drain must be installed to conform with local code. Run separate line for condensor discharge water on water cooled models.

INSTALLATION PRACTICE

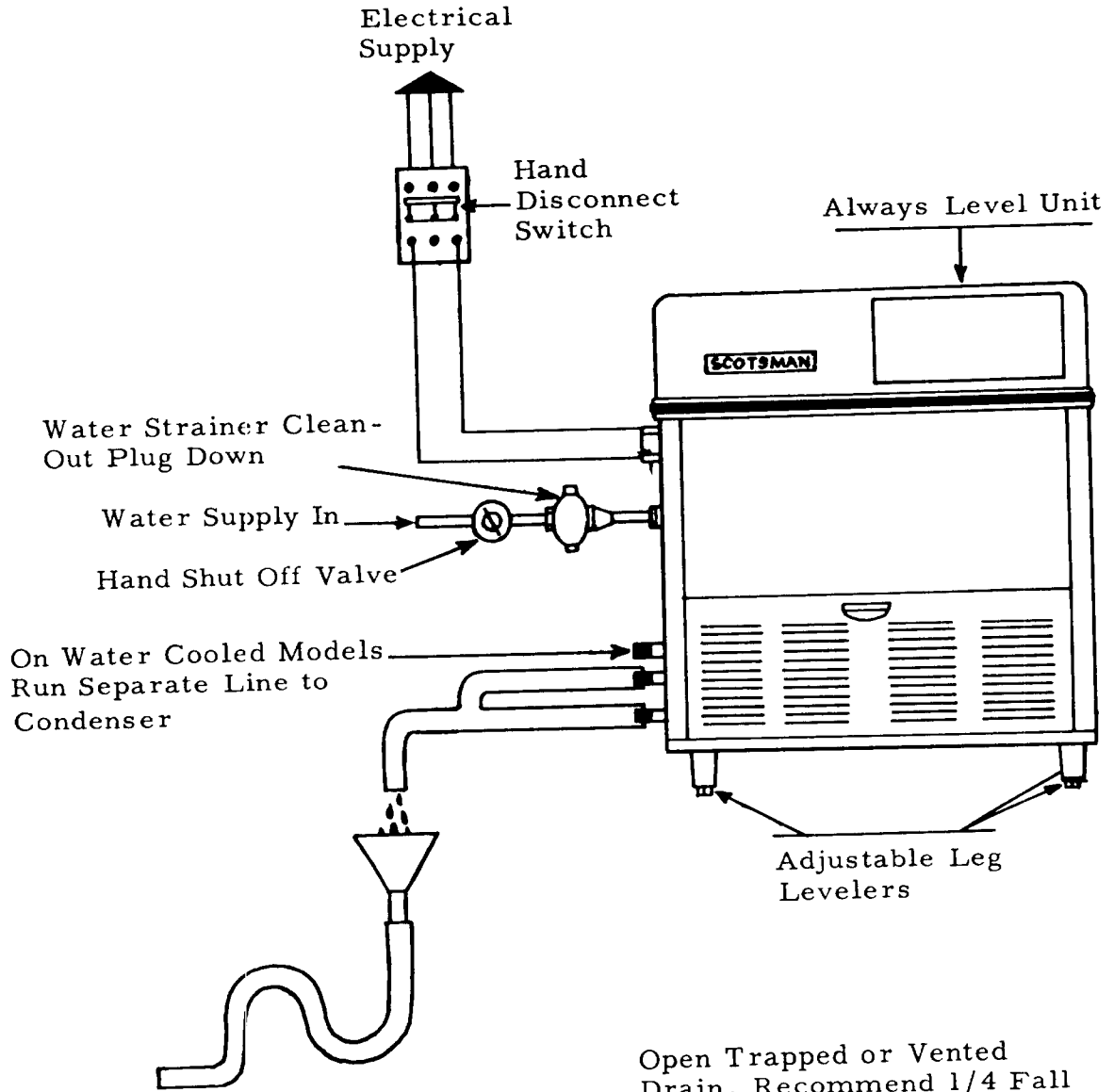

Open Trapped or Vented
Drain. Recommend 1/4 Fall
per foot of run on drain lines.

INSTALLATION

ELECTRICAL INSTALLATION:

		SF-2
Compressor	H.P.	1/2
	Voltage	115
	Amp. Rating	7.4
	Cycle	60
	Phase	Single
Drive Motor	H.P.	1/4
	Voltage	115
	Amp. Rating	4.5
	Cycle	60
	Phase	Single

ELECTRICAL CONNECTIONS:

SF-2-1

115 Volts

60 Cycle, 1 Phase

20 Amp. Circuit

Be certain that the Super Flakers are on their own circuit and individually fused. The maximum allowable voltage variation should not exceed 10 percent of the nameplate rating even under starting conditions. Low voltage can cause erratic operation and may be responsible for serious damage to the overload switch and motor windings.

All external wiring should conform to National Underwriters and Local Electrical Code requirements. Usually an electrical permit and the services of a licensed electrician will be required.

Open electrical control box and prepare for hook up, use knock outs, cord connectors etc. Then check unit name plate voltage against building source voltage and make sure they correspond. Caution--Improper voltage supplied to units will void your warranty protection.

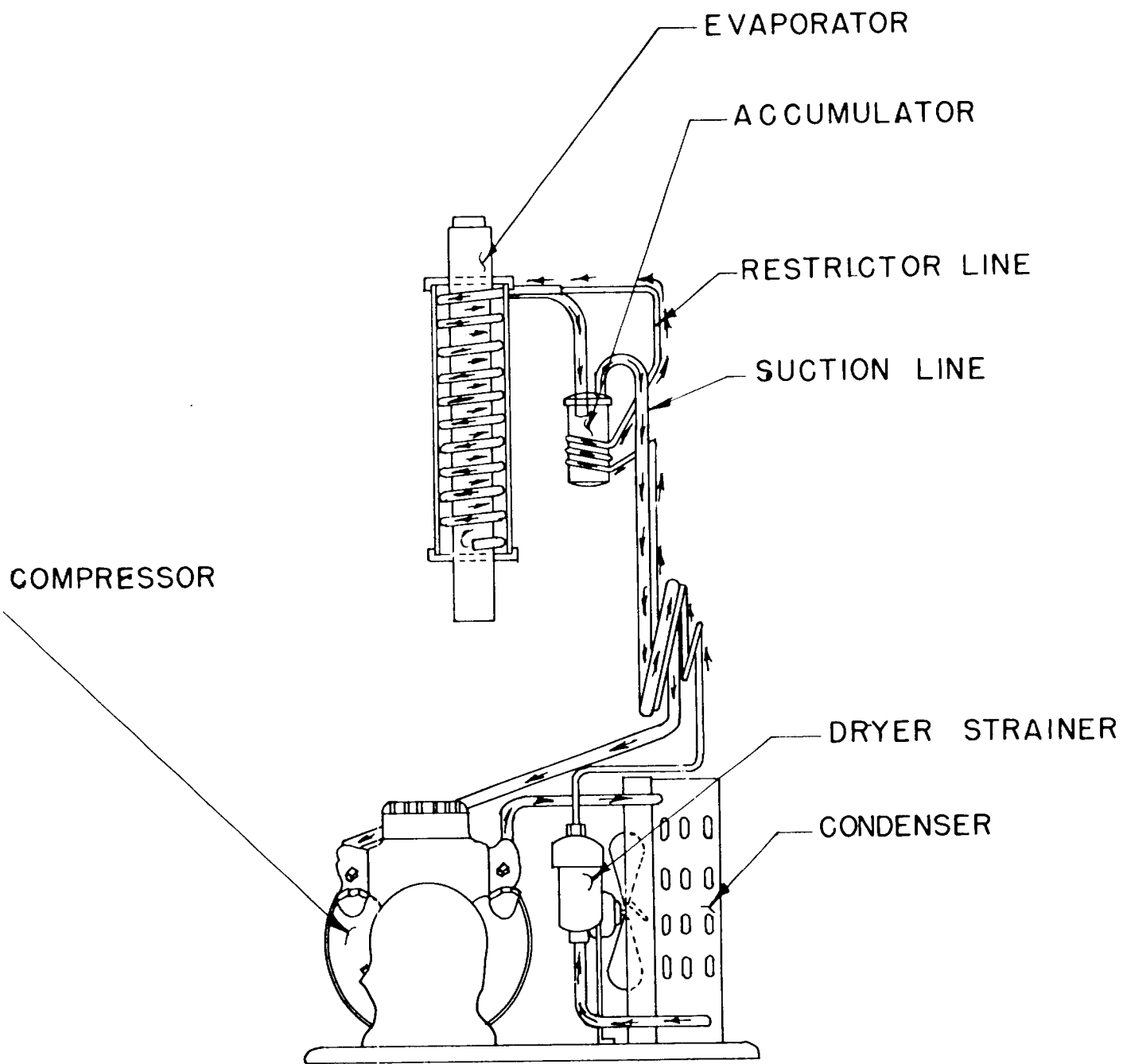

REFRIGERATION CYCLE SF-2 ALL MODELS

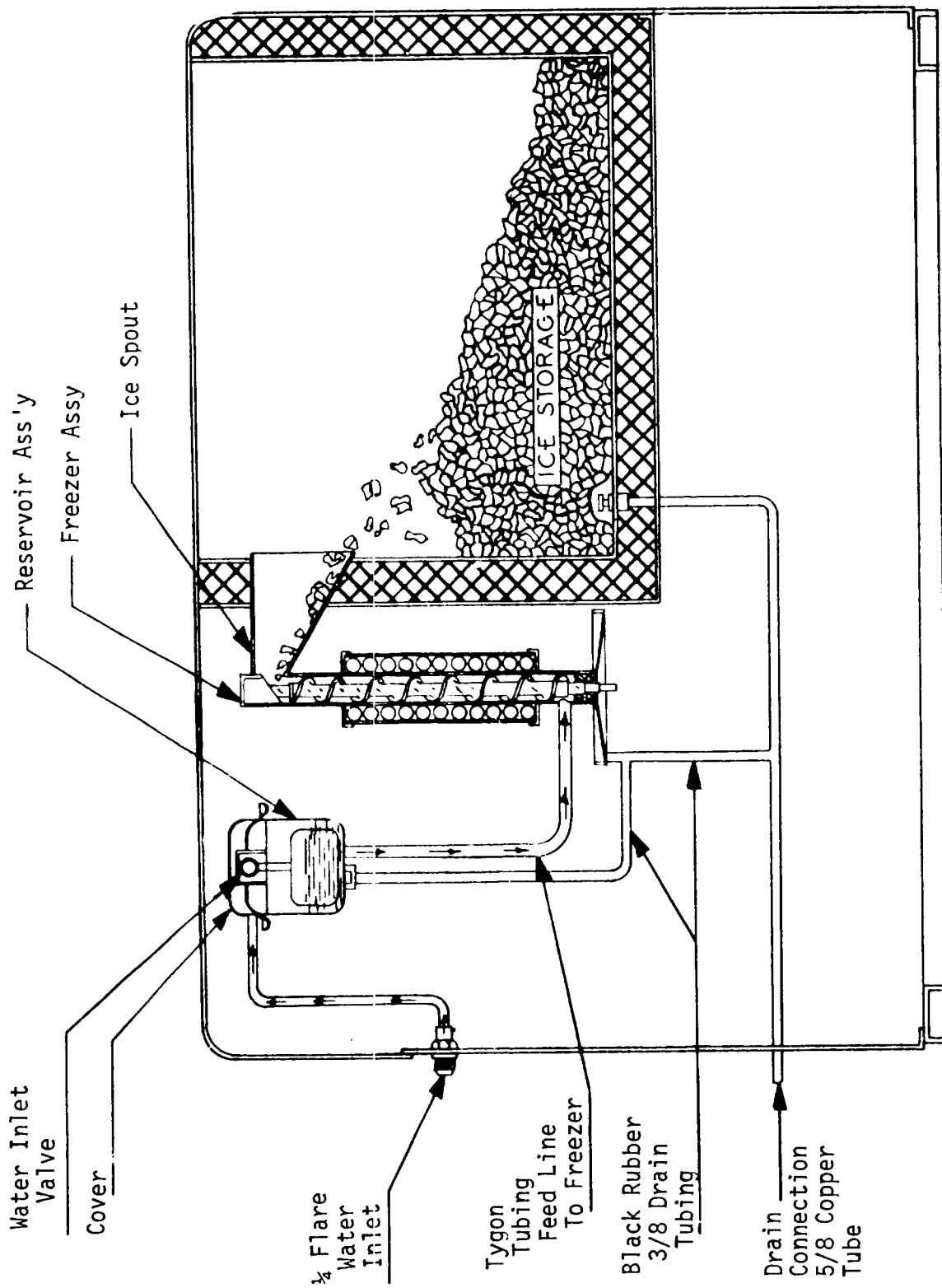

WATER SCHEMATIC

SF-2WSH

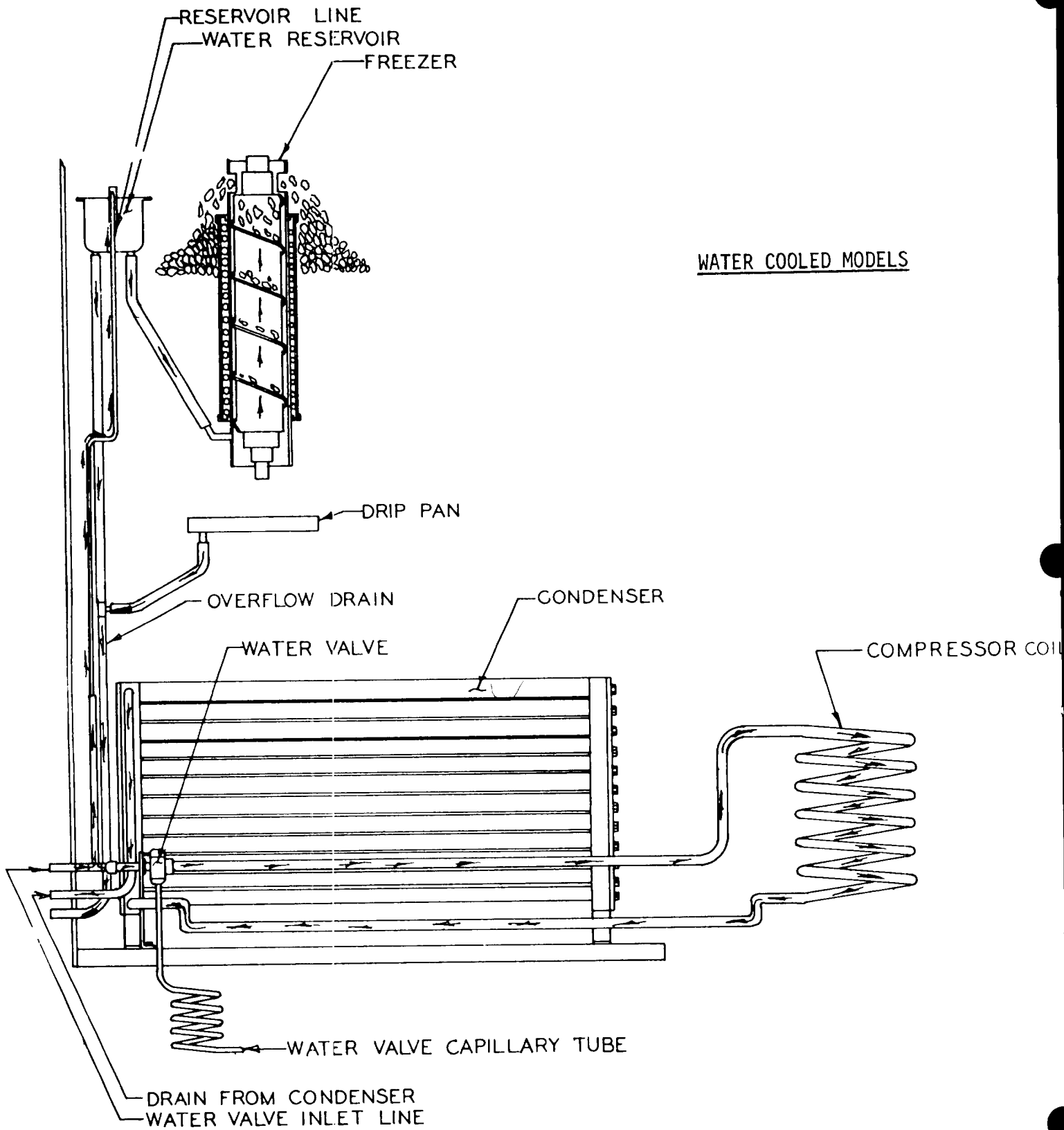

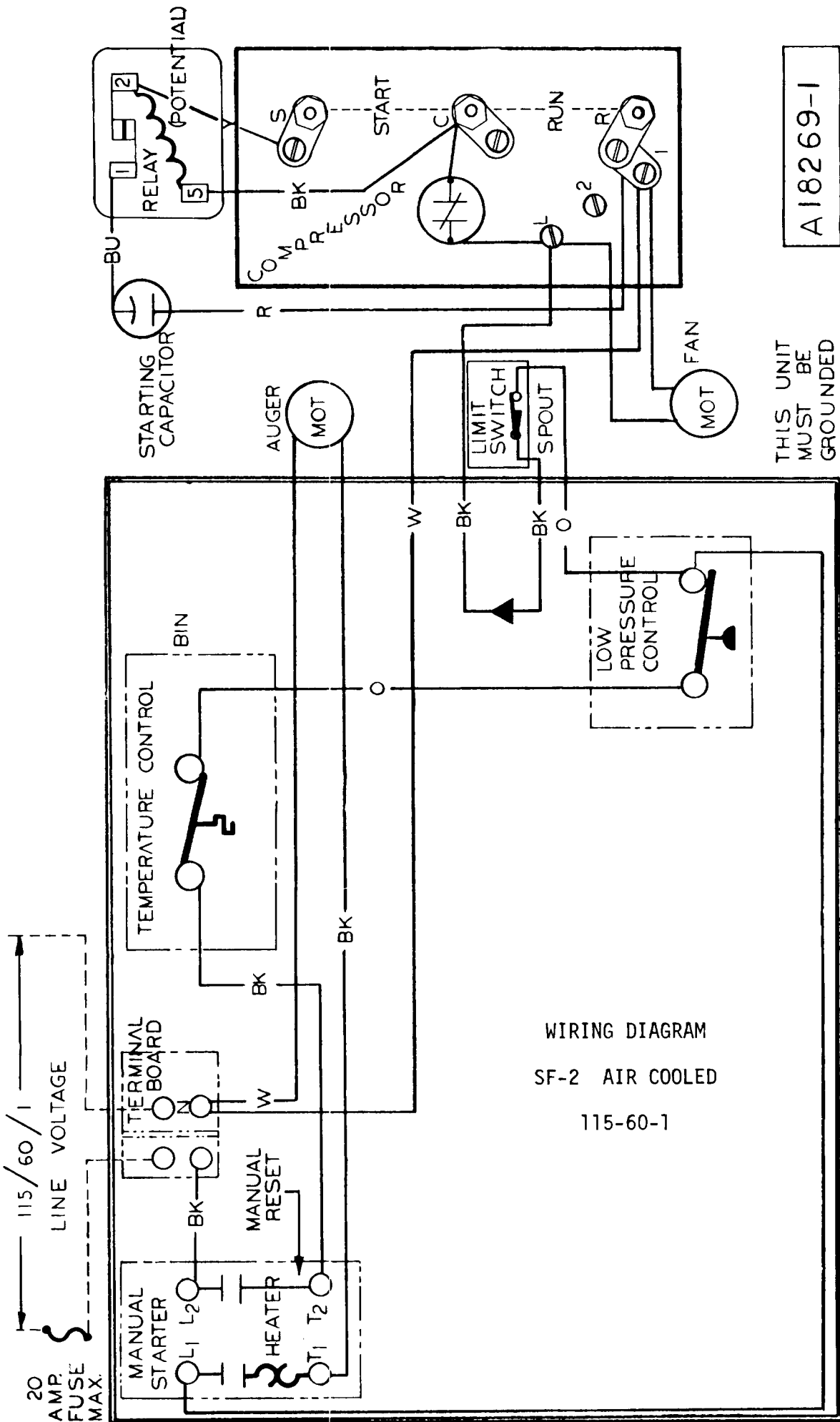

WIRING DIAGRAM
SF-2 AIR COOLED
115-60-1

A18269-1
THIS UNIT
MUST BE
GROUNDED

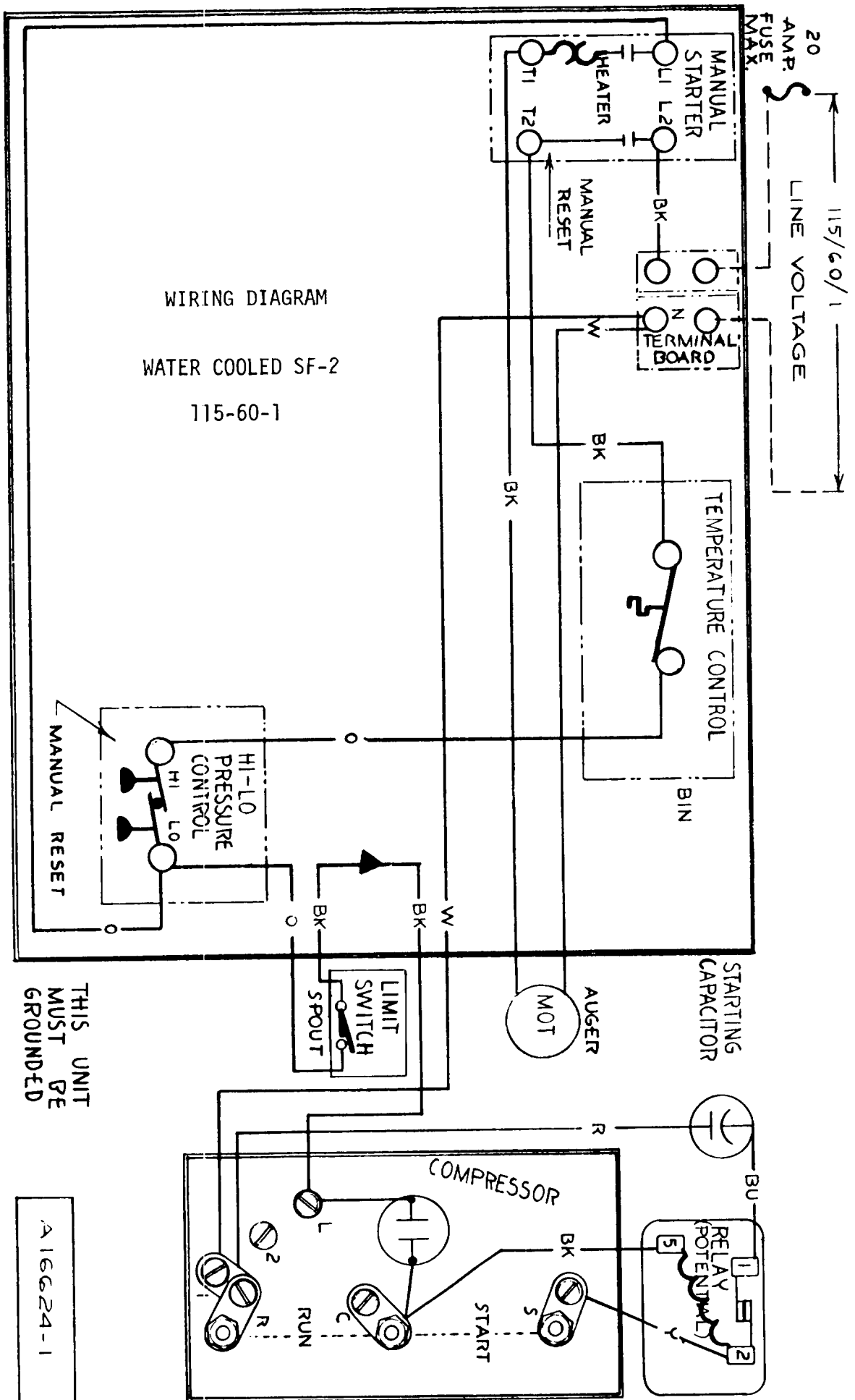

SERVICE

STARTING THE MACHINE

When the machine is placed and inspected as per instructions and all plumbing and electrical connections are completed and tested, turn on the water supply. Be sure the float cover is removed to check on the float operation and water level in the water reservoir. Be sure the water reservoir is filled before starting the machine. Water level should be 1/4 inch below the reservoir overflow.

When this is completed, turn on the manual switch on the front of the cabinet and the machine is in automatic operation. In two to three minutes ice will start dropping off the worm shaft and out the ice chute. Let the machine operate for at least 30 minutes, and check for any excess noise other than the normal compressor noise. Test the ice storage control bulb by holding a handful of ice around the bulb until the machine shuts off. One minute should be normal for the control to function. Within minutes after the ice is removed, the bulb will warm up and the machine will automatically start up. The control is factory set and should not be reset until this test is made. Normal setting of this control should be approximately 35 degrees cut-out and 45 degrees cut-in.

Check pressure settings at the time of start-up. On the water cooled models set the head pressure at 135 PSI. On the air cooled models the head pressure should be approximately 130 to 145 PSI head pressure. The frost line should extend 8" out of the accumulator if properly charged with refrigerant and suction pressure will range between 15 and 16 PSI with 50°F. inlet water.

Check the hand reset low pressure control setting. This safety device should be set at approximately 10 PSI below normal operating suction pressure and should cut off in case of interruption in water supply, shortage of refrigerant, low ambient or any other cause of abnormally low suction pressures. Observe pressure that machine pulls down to when first starting up. Set just below this pressure to avoid nuisance calls.

Explain the machine to the owner, showing him how the machine works and go over the owner's instruction sheet with him. Answer all the owner's questions about the machine, and do not leave with any doubt in the owner's mind about the machine, how to operate it or where to reach you should he need service on the machine. Call back the next day to check the machine again and answer any other questions the owner may have.

SERVICE

Service gauge connections are available on both high and low-side service valves.

To install gauges to any of these connections, replace 1/8 inch IP plug with 1/8 inch MPT x 1/4 inch flare half union. Purge free of any non-condensable gases before starting any test operation.

REFRIGERANT CHARGE

The below refrigerant charge is approximate. When charging, set at 135 PSI head pressure and charge so that the frost line extends out of the evaporator and into the accumulator after fifteen minutes of operation. Frost out of accumulator approximately 8 inches for best capacity.

<u>Model</u>	<u>Freon Charge</u>	<u>Oil Level</u>
SF-2	33 oz. R-12	Oil level should be kept at 1/3 way up sight glass. Do not fill over 1/2.

WATER SYSTEM

A water level is maintained in the water reservoir by a float operated valve. Water is piped from the water reservoir to the freezing chamber by a gravity feed line maintaining an equal water level. A removable overflow pipe is installed in the water reservoir for cleaning the reservoir as well as preventing damage should the inlet water valve fail.

The water reservoir is equipped with a 2 inch air gap to prevent back siphoning and meet all health codes.

The water level in the water reservoir is adjusted by bending float arm. The water level should be set 1/4 inch below the overflow pipe. A condensate drip pan is connected to the drain circuit to automatically dispose of condensate moisture.

A water strainer must be installed in the supply line.

SERVICE

ELECTRICAL SYSTEM

The Super Flaker model SF-2 is designed to work on standard voltage.

SF-2-1	115 volts	60 cycle	Single Phase
--------	-----------	----------	--------------

Special voltage requirements are available on special order. Therefore, always check nameplate for this information before checking electrical supply.

Nameplate voltage should not vary more than plus or minus 10 percent.

The electrical circuit consists of condensing unit, drive motor, hand reset combination or low pressure cut-out, storage bin thermostat, "on" and "off" switch, micro (safety) switches.

A. Condensing Unit

The compressor terminal box houses the motor compressor terminal block, and the motor overload Klixon. To gain access to the terminal box, remove the two screws holding the beveled metal cover. The starting capacitors, running capacitors and starting relays are housed and fastened to the chassis frame.

B. Drive Motor

Model SF-2 Flakers are equipped with standard 1/2 inch shaft, 1/4 HP., capacitor start, induction motors. These motors turn counter clockwise and may be replaced with any standard make motor corresponding to the nameplate rating. (Be sure motor runs counter clockwise viewed from the shaft end.) Nema 48 frame size.

C. High-Low pressure Cut-Out (Hand reset on water cooled models only.)

Ranco control is located on the frame assembly. Factory settings cut-out 5 lbs. on low pressure and 180 PSI on high pressure. This control prevents operation at abnormal pressures, temperatures or lack of water.

SERVICE

D. Low Pressure Cut-Out (Hand reset on all air cooled models.)

Ranco control is located in the control box. Factory settings cut-out at 5PSI. Safety devices to cut off machine and keep it off in case of water supply failure, loss of refrigerant, low ambient temperature or other causes of low pressure.

E. Storage Bin Thermostat

Control located in control box. Factory settings 35° cut-out, 45° cut-in. This control shuts off complete machine when ice in storage bin builds up to control bulb, automatically starts machine upon ice removal.

F. Micro Safety Switch

The micro switch is located in the top of the ice chute. The switch is operated by a plate in top of the ice chute by the ice backing up in the chute should the storage bin thermostat fail. Micro switch will shut off the condensing unit only, when operated, drive motor continues to run.

G. On-Off Switch -- Manual

A General Electric or Westinghouse on-off switch with built in thermal overload protection to prevent drive motor failures is used. Since any one of three makes of motors may be used, consult chart in parts section of this manual for correct overload protector usage.

REMOVAL & INSTALLATION OF PARTS

CABINET TOP (HOOD)

1. Remove two back end screws of chrome strip.
2. Pull out tape concealing screws.
3. Remove balance of screws in chrome strip.
4. Lift off hood.

HOOD SERVICE DOOR

1. Remove two screws on top edges.
2. Lift off door.

CABINET SIDE SERVICE DOOR

1. Remove four screws on edges.
2. Lift out door.

CABINET FRONT SERVICE DOOR

1. Front door pulls out.

CABINET REAR SERVICE DOOR

1. Remove four screws on corners of rear service door.
2. Pull door out.

ICE STORAGE DOOR

1. Raise and push door six inches rear of track. Hold up on underside of door - pull forward.
2. Door will now slide out.

ICE STORAGE DOOR FRAME

1. Remove six screws at bottom and sides.
2. Frame will now lift out.

MOTOR COMPRESSOR

1. Front seat both suction service valve and discharge service valve on compressor.
2. Disconnect wiring from the compressor. Also any control capillaries.
3. Remove the bolts holding the service valve to the compressor.
4. Remove the compressor hold-down nuts and lift compressor out of the units.
5. Reverse steps 1 through 4 in replacing compressor.
6. Check the oil in the compressor before connecting lines. Sight glass not over 1/2 full.

SERVICE

MICRO SWITCH IN SPOUT

1. Remove hood service panel.
2. Remove micro box cover, loosen two screws at rear of box holding switch in place, lift up.
3. Disconnect electric leads.
4. Reassemble with new micro switch.

DRIVE MOTOR

1. Remove case hood - See Cabinet Top Removal Section.
2. Remove electrical connections.
3. Remove four base bolts.
4. Remove drive belt.
5. Lift out defective motor.
6. Remove pulley and install new motor.
7. To replace, reverse procedure.
8. CAUTION: Drive motor rotation is COUNTER-CLOCKWISE facing shaft end.

MANUAL ON AND OFF SWITCH

1. Remove front service door.
2. Remove control box cover.
3. Remove two screws holding switch box bracket.
4. Disconnect electrical leads from switch.
5. Remove switch.
6. To replace, reverse procedure.

GEAR REDUCER AND COUPLING

1. Remove rear door.
2. Remove drive pulley.
3. Loosen drive coupling set screw and slide down on gear reducer shaft.
4. Loosen four mounting bolts.
5. Lift out from rear of machine.
6. To replace, reverse procedure.
7. Check new gear reducer for proper oil level.

FREEZER ASSEMBLY

1. In most instances, it will be faster to facilitate freezer removal by removing cabinet top or hood. (See Removing & Installing Cabinet Parts.) Assembly can be changed if necessary through hood top panel.
2. Shut off water supply and drain water reservoir.
3. Remove refrigerant from system.
4. Remove suction and liquid line connections. (CAUTION: Plug all connections to prevent moisture from entering system.)
5. Remove tygon tube to water inlet connection at base on freezing chamber.
6. Loosen knurled nut holding spout to freezer and remove.
7. Remove two bolts holding freezer chamber to frame.
8. Lift freezer assembly up and out of unit.
9. Remove rubber drip pan from defective assembly and install it on new assembly.
10. Reverse above procedure to install new assembly.

WORM SHAFT

1. Turn unit off, before removing worm shaft.
2. Shut off water supply to unit.
3. Remove hood service door. Remove straps and insulation halves on freezer top.
4. Remove two slotted head screws which fit through chamber wall into ice breaker. See page 28 items 11, 12.
5. Complete worm shaft with ice breaker attached will now come out by lifting up on freezer cap pull ring. NOTE: Top half of water seal will come out with worm shaft.
6. To remove ice breaker from shaft, first remove retainer ring in top of ice breaker.
7. Remove freezer cap and pull ring from ice breaker.
8. Loosen hex head bolt holding shaft through bearing and pull worm shaft free from ice breaker and bearing.
9. If shaft is defective, remove water seal top half and put on new worm shaft before reassembling - when reassembling, by reversing above, put a small amount of Vaseline on squared shaft end. This will allow shaft to slide smoothly through rubber bottom half of water seal without tearing it.

WATER SEAL

1. To replace water seal, follow steps 1 through 6 under Worm Shaft Removal.
2. Next slide three-jaw drive coupling down on reducer or else remove top half of coupling.
3. Pull rubber drip pan down.
4. Remove large brass nut holding lower bearing and lower portion of water seal in place.
5. Lightly force lower bearing out.
6. Reach in and pull bottom portion of water seal out.
7. Reassembly is reverse of above.

SERVICE

STORAGE BIN THERMOSTAT

1. Disconnect electrical supply.
2. Remove bin thermostat bulb from bin location along with its capillary tube.
3. Remove control box cover.
4. Remove two screws in control mounting bracket.
5. Disconnect two leads.
6. Replace with new control and reassemble in reverse of above.
7. CAUTION: Always check new control power element charge before installation to assure receiving an operative control. A handful of ice on bulb will register an audible 'click' at cut-off. Settings 35° cut-out, 45° cut-in.

WATER RESERVOIR

1. Remove service panel in cabinet hood.
2. Turn off water supply and drain reservoir.
3. Remove 1/4 inch copper inlet water line.
4. Remove 1/2 inch plastic feed line to freezer.
5. Lift out reservoir after removing two screws holding bracket to frame.
6. To replace, reverse procedure.

HAND RE-SET LOW PRESSURE CUT-OUT SWITCH

1. Disconnect electrical supply.
2. Remove control cover.
3. Put jumper across control wires if needed. Connect electrical supply and pump down to one pound PSI on lowside gauge. Front seat suction service valve.
4. Disconnect electrical supply again, then remove electrical lead to the control.
5. Loosen cap tube from crankcase and remove complete control. Cap up 1/4 inch flare fitting.
6. Install new control, being sure to purge at crankcase fitting when tightening up refrigerant connection. Back seat suction service valve.

SF-2 H CHASSIS ASSEMBLY

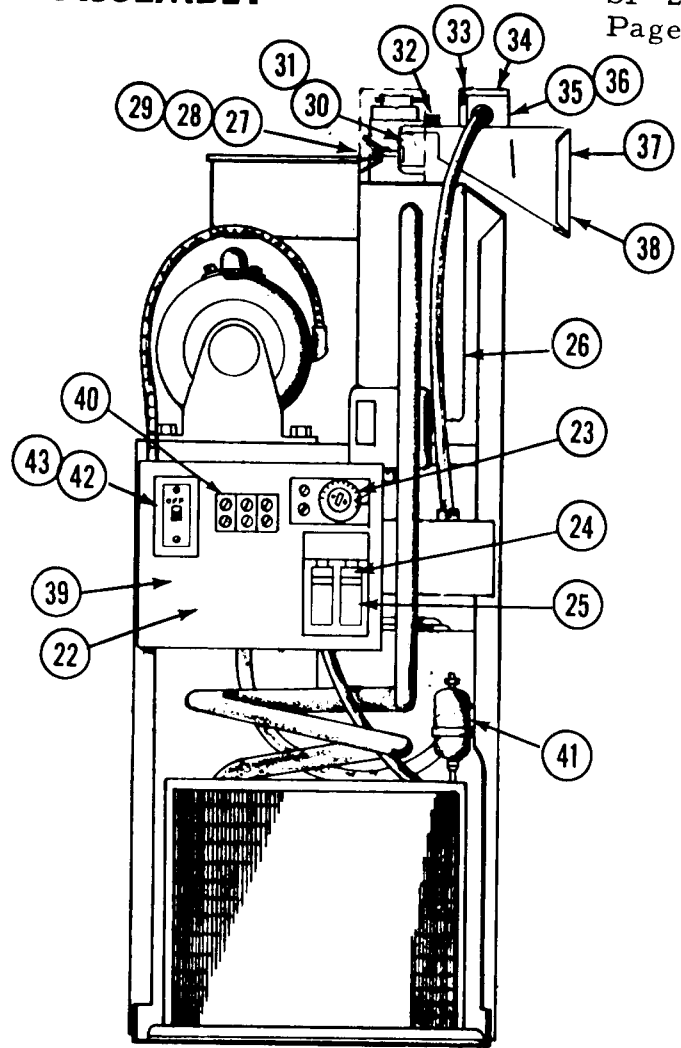
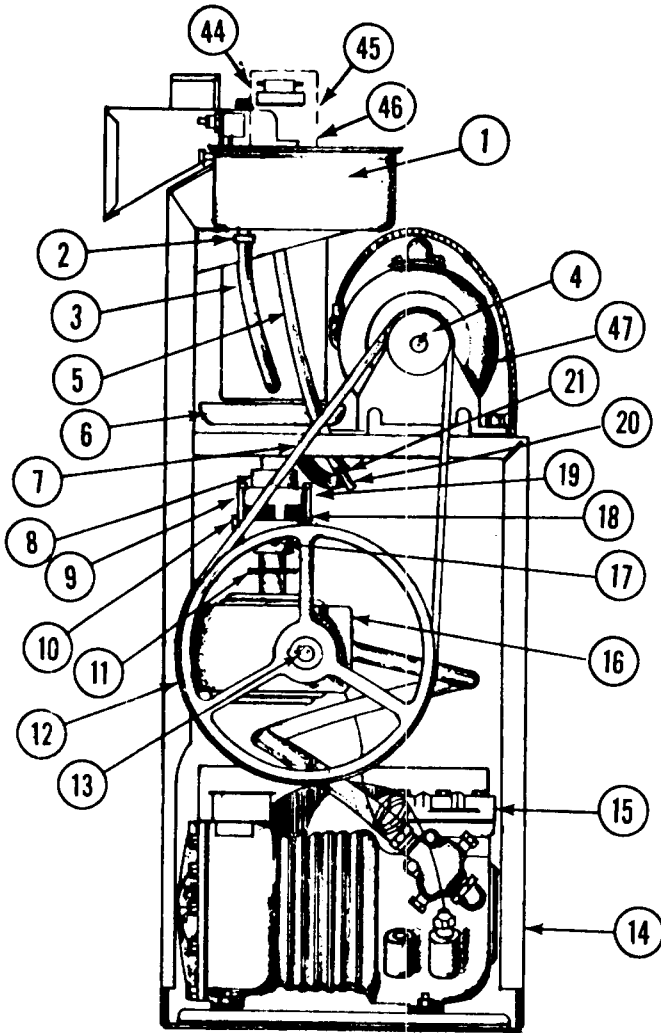

ITEM NO.	PART NO.	NAME
1.	A-8339	Reservoir Assembly
2.	2-694	Clamp
3.	5-186	Tygon Tubing (1/2 ID x 3/4 OD (per foot)
4.	2-1462	Pulley <i>2.5" Pulley Diameter</i>
5.	13-79	Tubing (rubber) (per foot)
6.	13-208	Rubber Drip Pan
7.	13-558	Belt
8.	A-6165	Coupling, top <i>(1/2" dia)</i>
9.	S-8496	Coupling clamp (2)
10.	3-206	Cap Screws (2)
11.	13-152	Rubber Shield
12.	2-1463	Pulley (8")
13.	S-6035	Key
14.	A-15977	Frame
15.	18-325	Motor Compressor 115/60/1 AC
	18-355	Motor Compressor 115/60/1 WC
16.	2-337	Gear Reducer
17.	3-385	Set Screw
18.	S-7716	Coupling, bottom <i>3/4" dia</i>
19.	13-131	Coupling Insert <i>3/4"</i>
20.	A-7387	TEE Assembly (7/16")
21.	2-535	Clamp
22.	11-264*	High-Pressure Control (*)
23.	11-99	Bin Control
24.	A-15384	Cover Resistor **
25.	12-474	Resistor (***)
26.	A-6991-3	Freezer

ITEM NO.	PART NO.	NAME
27.	A-6665	Casting Spout Holder
28.	3-679	Lockwasher (2) <i>03-1417-87</i>
29.	3-721	Screw (2) <i>03-1417-67 03-1463-55</i>
30.	2-1437	"O" Ring
31.	A-14269	Casting
32.	A-14256	Nut, knurled
33.	3-173	Screws (2)
34.	A-14241	Limit Box Cover
35.	12-1018	Micro Switch (**)
36.	A-14975	Limit Box
37.	A-16353	Pressure Plate (**)
38.	A-16350	Spout
39.	11-273-1 *	Low-Pressure Control
40.	12-1308	Terminal Board
41.	2-544	Drier
42.	12-1220	Manual Switch (w/case) **
	12-1220A	Manual Switch (less case)
43.	12-1221	Overload ***
44.	A-15081	Left Spout Insulation
45.	A-15080	Right Spout Insulation
46.	A-8736	Clamps (2)
47.	12-864-1	Drive Motor 115/60/1
	12-864-2	"48" Frame 230/60/1

(*) Not on water cooled
 (**) Not shown
 (***) See Overload chart on page 44 for correct dash no.

FREEZER ASSEMBLY SF-2H

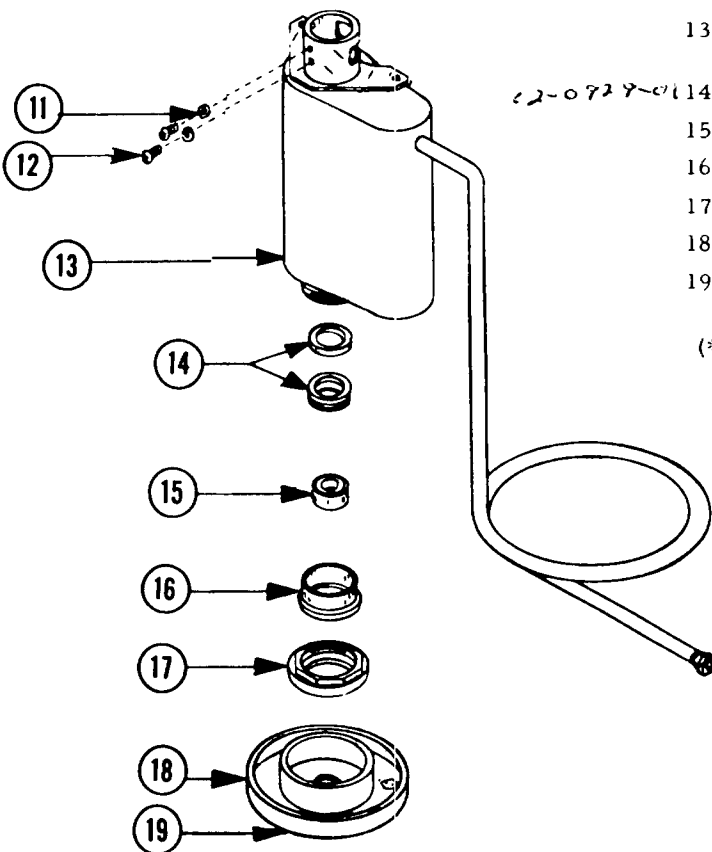
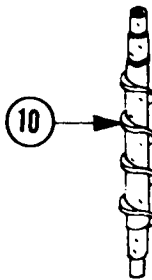
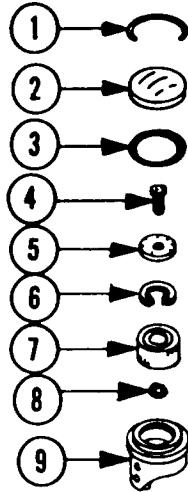

ITEM NO.	PART NO.	NAME
1.	A-8582	Cap Hook
2.	A-8581	Worm Tube Cap
3.	2-560	'O' Ring
4.	3-715	Cap Screw
5.	A-6273-002	Worm Tube Washer
6.	3-712	Snap Ring
7.	2-646	Top Bearing
8.	2-643	'O' Ring
9.	A-8316	Ice Breaker
10.	2-617	Worm Shaft
11.	3-679	Lock Washers
12.	3-732	Screws (brass 1/4x20x5/8)
13.	A-6382	Suction Line, Worm Tube, Cap Tube Assembly
14.	2-929	Water Seal
15.	2-619	Bearing, lower
16.	A-10591	Bearing Retainer
17.	A-6153	Worm Tube Nut
18.	13-208	Rubber Drip Pan
19.	A-8002	Drain Tube (*)
	A-6991-3	Freezer Complete
	(*)	Not Shown

13-0617-20

13-0617-15

→ A26704-001

2-0729-01

RESERVOIR ASSEMBLY

Part No. A-8339

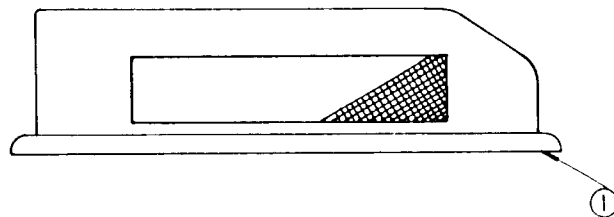

ITEM NO.	PART NO.	NAME
1.	A-16012	Reservoir Cover *
2.	2-1259	Valve Pin
3.	2-1320	Deflector
4.	S-8770	Inlet Valve
5.	3-1001	Rivet
6.	A-5777	Valve Seat Holder
7.	S-6947	Valve Seat
8.	S-7044	Nut
9.	A-12869	Bracket
10.	S-6715	Stand Pipe
11.	S-8138	Inlet Valve Ass'y
12.	A-13409	Reservoir Body
13.	A-8055	Bracket Nut
14.	A-12067	Float and Arm Ass'y
15.	A-18418	Water Deflector
	A-8339	Complete-less cover

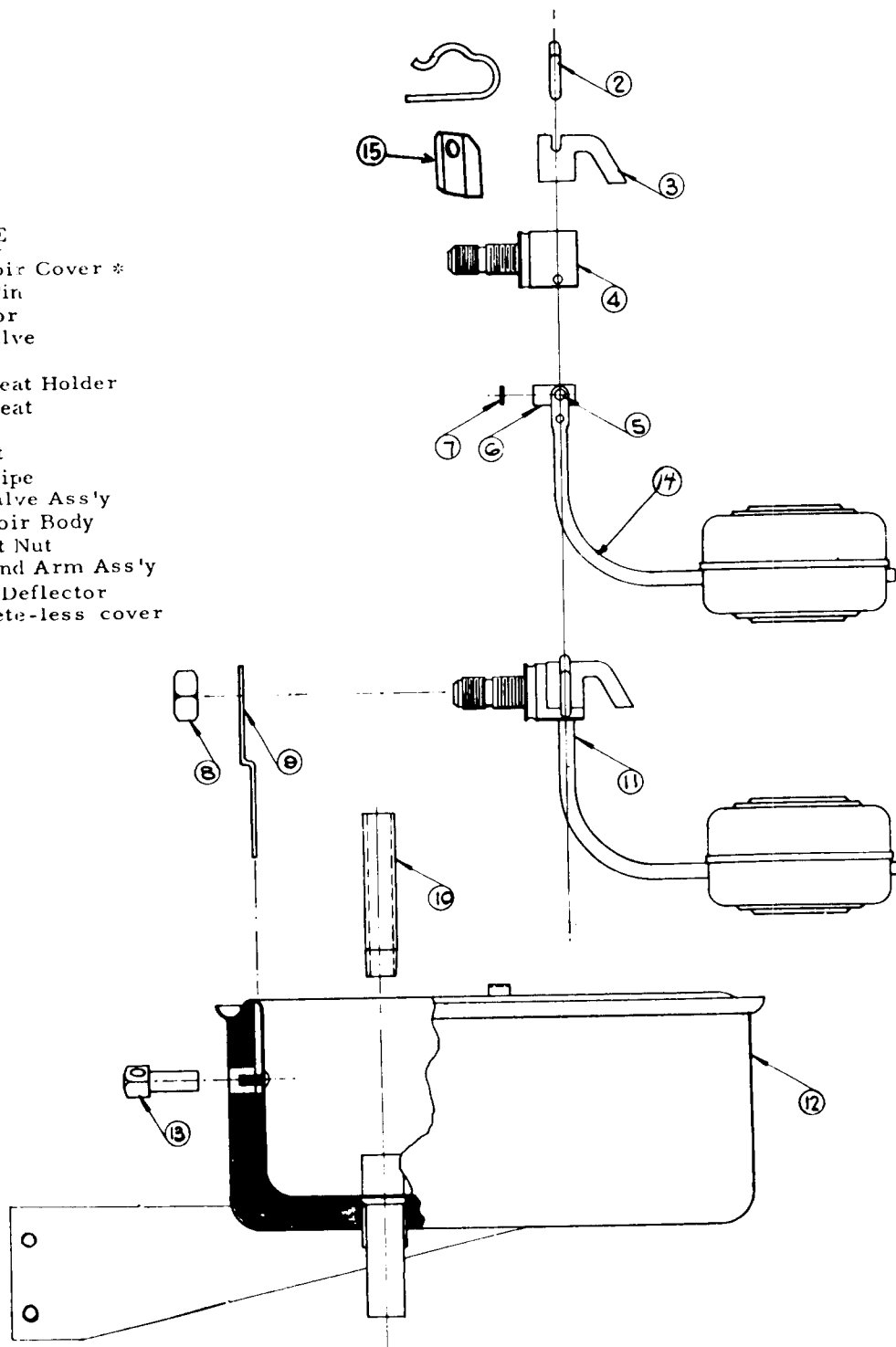

GEAR REDUCER

Part No. 2-337
Winsmith Part No. (3CTS)

ITEM NO.	PART NO.	NAME
1.	2-580-28	Slow-Speed Gasket (2)
2.	2-580-24	Slow-Speed Seal (2) (0.2-0580-24)
3.	2-580-26	Slow-Speed Bearing (2)
4.	2-337-20	Slow-Speed Gear & Shaft
5.	2-768-25	High-Speed Gasket (2)
6.	2-337-23	High-Speed Bearing (2)
7.	2-768-20	High-Speed Seal (0.2-0768-20)
8.	2-337-21	High-Speed Gear & Shaft (integral)
9.	2-580-27	Slow-Speed Spacers (2)
	2-337	Complete Reducer

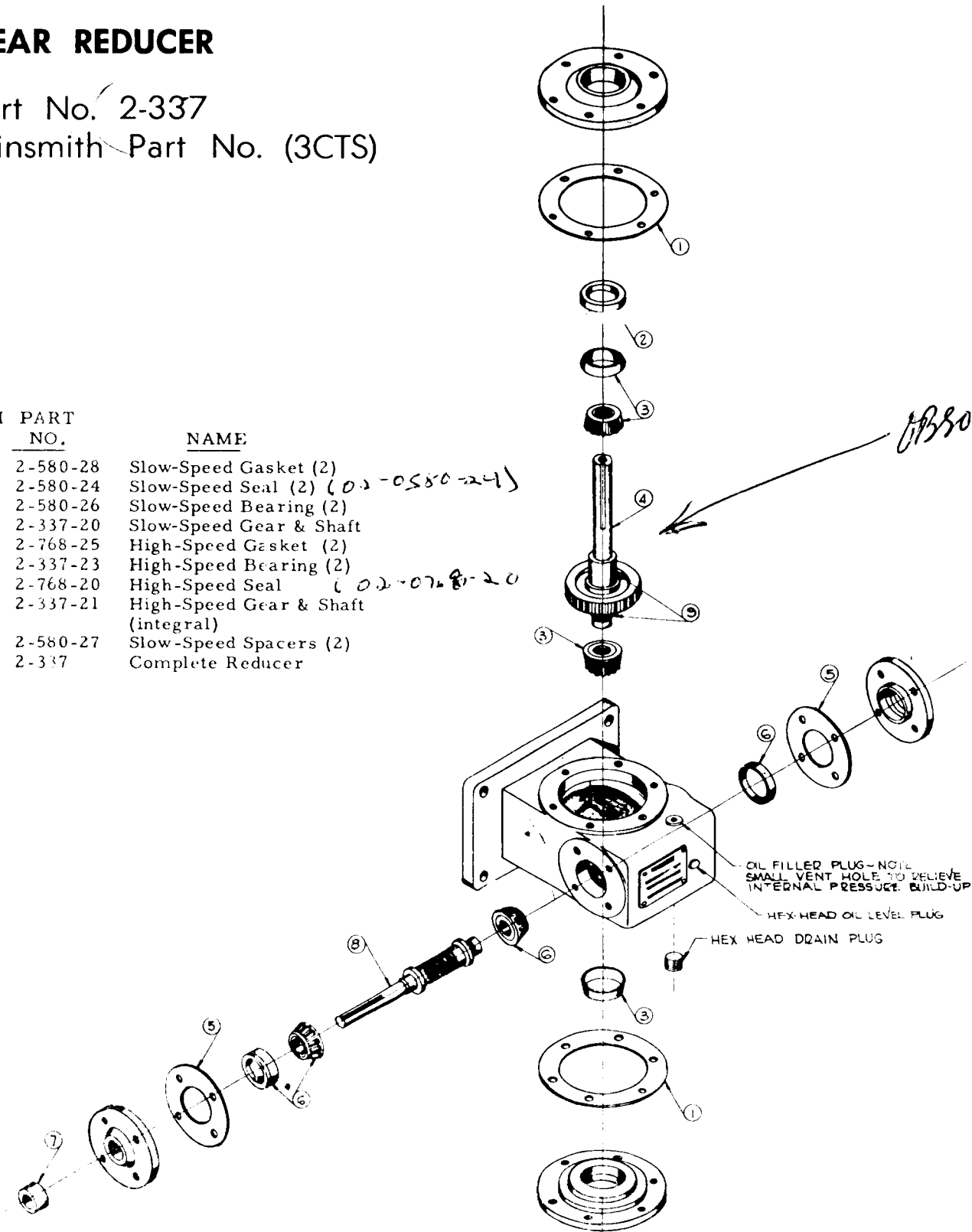

In answer to many field requests, we are pleased to release the following chart showing the companies whose products are acceptable substitutes for the 600W supplies by Winsmith as factory recommended.

Note the third column which most accurately represents the normal temperature operating range. Also the Alemite or Zerk fitting to bearing is greased with Mobilgrease BRB No. 1, or any good ball bearing grease as obtained from local service stations.

600W oils and equivalents are classified as industrial oils and most likely will be found in bulk plants rather than local service stations.

WORM GEAR REDUCERS

CB-CT-CV-CBD-CTD-CVD-CBX-CTX-CVX-DBI-TSR

Ambient Temperature °F	-30 to 15	16 to 50	51 to 110	111 to 165
Maximum Operating Temp. °F	150	185	225	225
Viscosity @ 210°F, SUS	40 to 90	90 to 125	125 to 190	190 to 350
Compounded with	(Optional)	3 to 10% Acidless Tallow or E. P. Base	3 to 10% Acidless Tallow or E. P. Base	3 to 10% Acidless Tallow or E. P. Base
AGMA Lubricant		#7 Compound	#8 Compound	
Cities Service Oil Co.	Pacemaker Oil # 5	Optimus Oil # 10	Optimus Oil # 6	Optimus Oil # 12
Fiske Bros. Refining Co.	#3 Lubriplate	Lubriplate # 8	Lubriplate # 8	Lubriplate APG
Gulf Oil Corporation	Multipurpose Gear Lubricant	E. P. Lubricant #115	E. P. Lubricant #145	E. P. Lubricant #250
Shell Oil Company	Vitrea Oil 71	Valvata Oil #J 78	Valvata Oil #J 78	Valvata Oil #J 83
Sinclair Refining Co.	Duro Oil 160	#87 Heavy Duty Oil	#101 Super-Heat Valve Oil	#112 Super-Heat Valve Oil
Standard Oil Co.	Stanogear Compound # 1	Stanogear Compound # 4	Standard Worm Gear Oil	Colmac 500 Colmac Oil
Sun Oil Company	Sunep 70	Sunep # 110	Sunep # 110	Sunep # 110
Socony Mobil Oil Co., Inc.	Vactra Oil # 1	Mobil Compound DD	Mobil Cylinder Oil #600W	Mobil Cylinder Oil #600W
Texas Company	Meropa Lub. # 1	Meropa Lub. # 3	Meropa Lub. # 6	Meropa Lub. # 6

SF-2WSH CASE ASSEMBLY

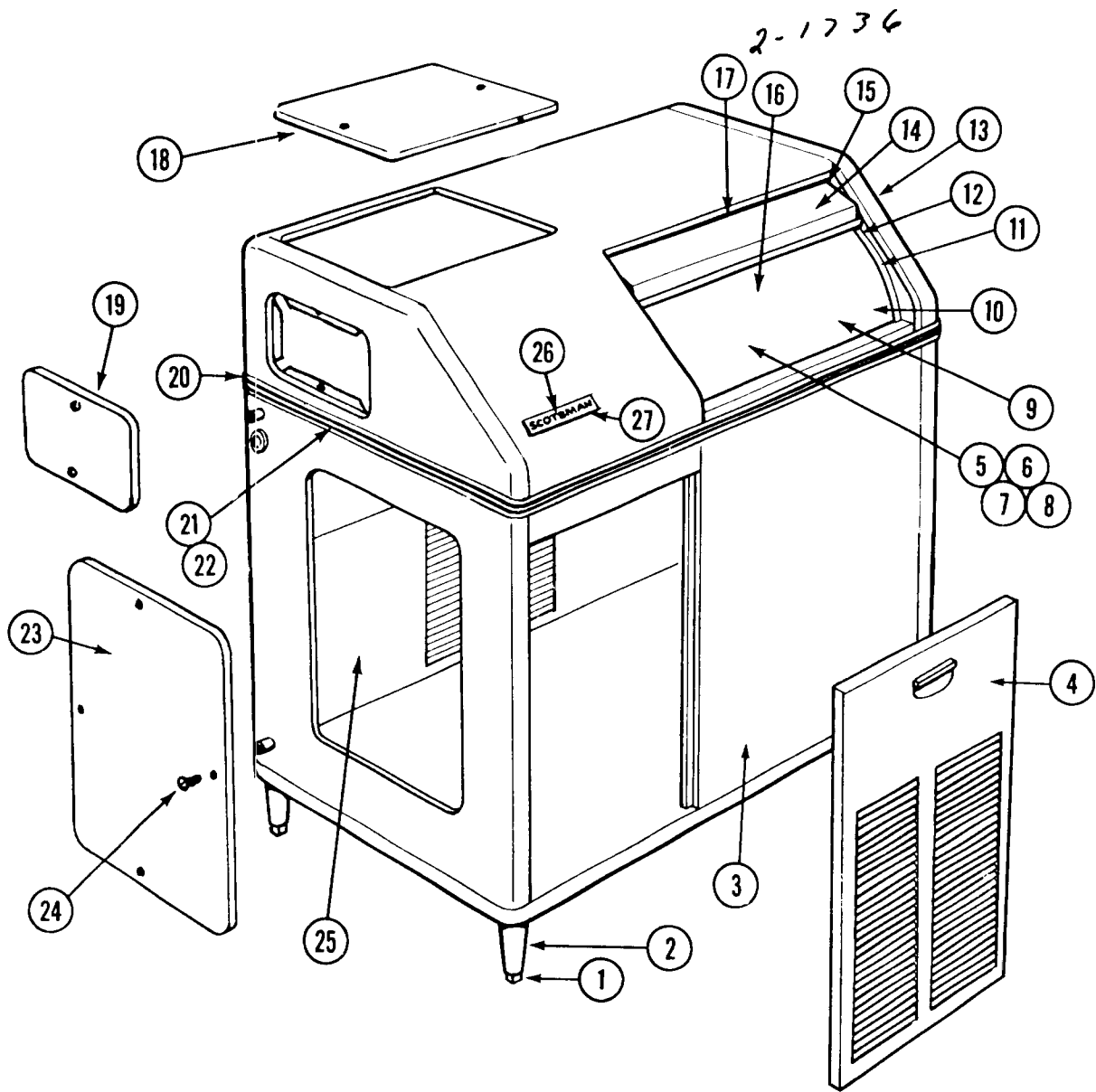

ITEM NO.	PART NO.	NAME
1.	8-522	Leg Leveler
2.	A-15803	Leg
3.	A-16078	Case Assy.
4.	A-15793	Front Door
5.	A-18093	Drain Assy. *
6.	2-530	"O" Ring *
7.	A-18090	Storage Bin Fitting *
8.	A-6448	Drain Screen *
9.	A-15774	Storage Bin Assy. *
10.	A-15779	Insulation Layout
11.	3-640	Door Glides (door)
12.	3-1195	Door Glides (hood)
13.	A-15601	Case Hood Assy.
14.	A-15559	Sliding Door

ITEM NO.	PART NO.	NAME
15.	A-16208	Door Track
16.	3-1212	Bulb Holder *
17.	A-16209	Door Catch * <i>2-1616-ccc</i>
18.	A-7676	Top Door
19.	A-6530	Top Side Door
20.	A-5829	Rear Trim Strip *
21.	15-324	Plastic Moulding-trim
22.	S-6413	Front Moulding Strip
23.	S-6713	Side Door
24.	3-775	Screw S.S.
25.	A-8741	Rear Door
26.	15-156	Emblem
27.	3-271	Speednut

*Not Shown

SF-2H CASE ASSEMBLY

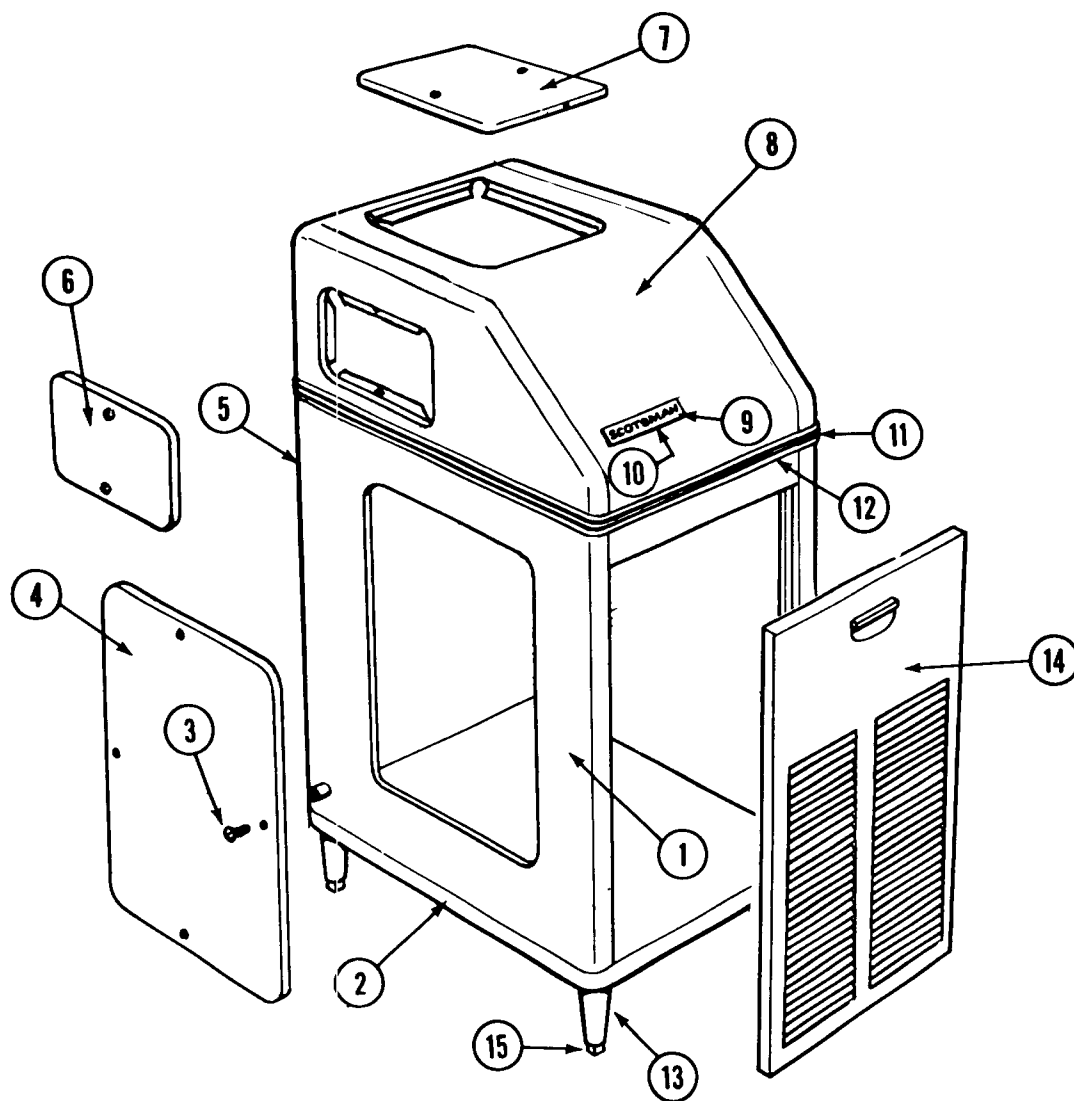

ITEM NO.	PART NO.	NAME
1.	A-16077	Case Assembly (less doors)
2.	A-8902-2	Moulding Strip (bottom) (2 reqd.)
3.	3-775	Screw (s.s.)
4.	S-6713	Side Door
5.	A-8741	Rear Door (*)
6.	A-6530	Top Side Door
7.	A-7676	Top Door
8.	A-16194	Case Hood (less doors)
9.	15-156	Scotsman Emblem
10.	3-271	Speed Nuts
11.	15-324	Plastic Trim Insert
12.	S-6211	Moulding Strip (top)
13.	A-15803	Legs (4 reqd.)
14.	A-15793	Front Door
15.	8-522	Leg Levelers (4 reqd.)

(*) Not Shown

CONDENSING UNIT

½ HP Water Cooled, Copeland

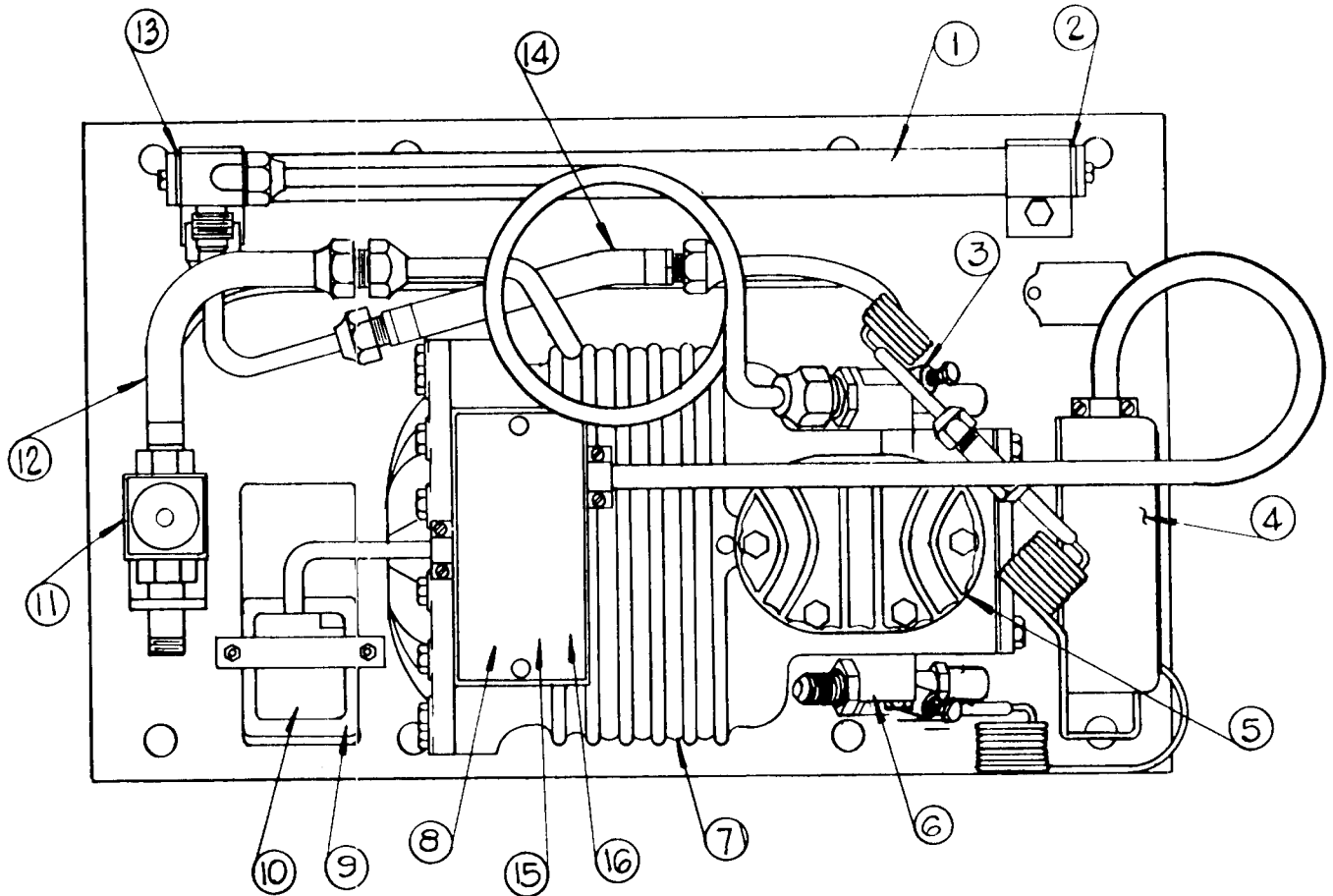

NOTE: Not available as a complete mounted assembly.

ITEM NO.	PART NO.	NAME	ITEM NO.	PART NO.	NAME
1.	18-368	Condenser	11.	11-198	Water Valve
2.	18-262	Plain Gasket	12.	18-260	Compressor to Valve Water Hose
3.	18-237	Discharge Service Valve	13.	18-263	Manifold Gasket
4.	11-286	High Pressure Control	14.	18-261	Compressor to Condenser Water Hose
5.	18-326	Valve Plate & Gasket Kit Assembly (*)	15.	18-270	Terminal Board (*)
6.	18-337	Suction Service Valve	16.	18-241	Terminal Assembly (*)
7.	18-355	Motor Compressor 115/60/1	If Possible Use Copeland Part No When Ordering Capacitors & Relays.		
8.	18-347	Klixon Overload (*)	(*) Not Shown		
9.	18-1901-7	Starting Capacitor			
10.	18-1903-4	Relay			

CONDENSING UNIT

½ HP Air Cooled, Copeland

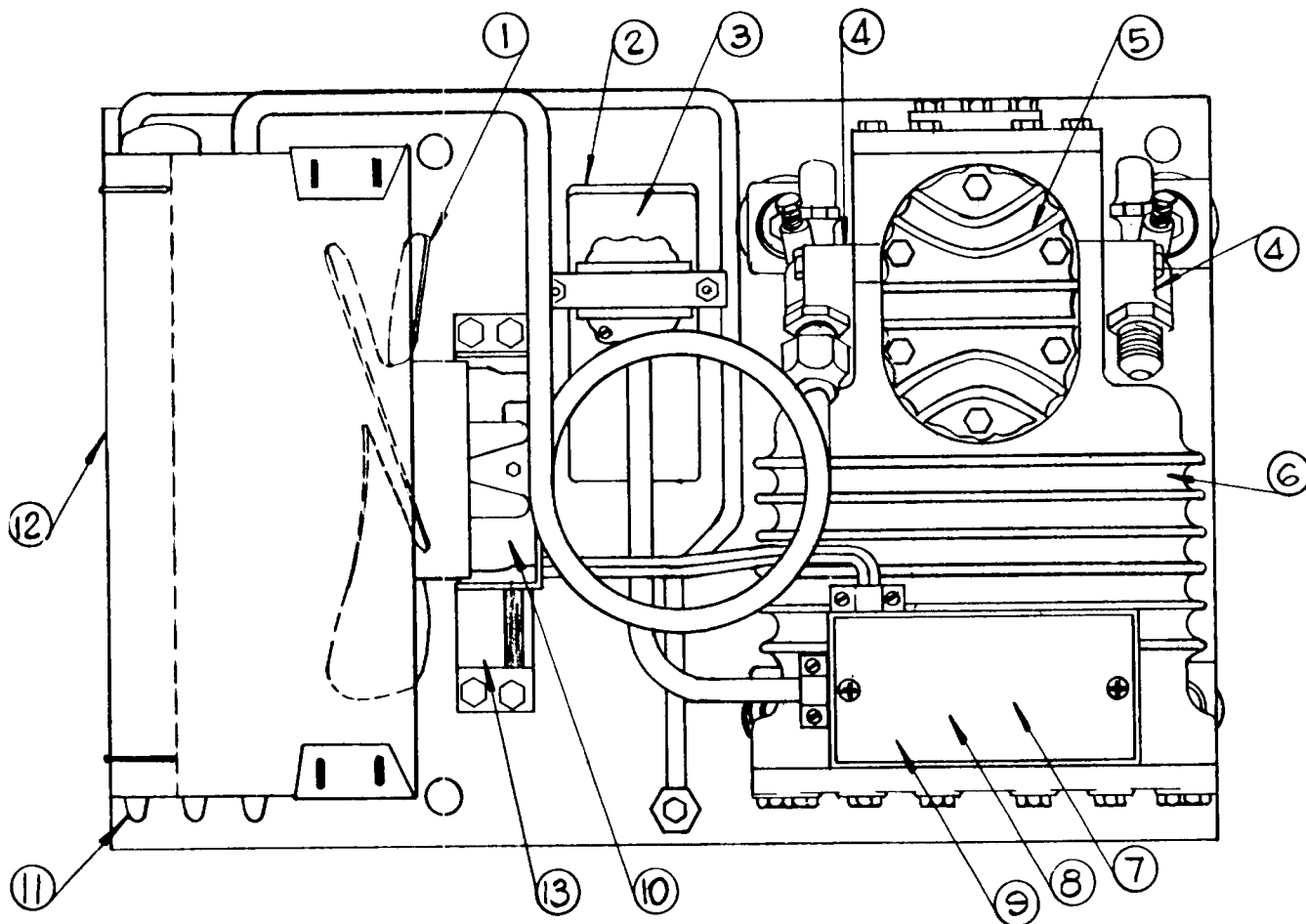

NOTE: Not available as a complete mounted assembly.

ITEM NO.	PART NO.	NAME	ITEM NO.	PART NO.	NAME
1.	18-363	Fan Blade	9.	18-270	Terminal Board (*)
2.	18-1901-7	Starting Capacitor	10.	18-333-1	Fan Motor
3.	18-1903-4	Relay	11.	18-334	Condenser
4.	18-337	Suction, Service Valve (18-237 Discharge Valve)	12.	A-12111	Shroud
5.	18-326	Valve Plate & Gasket Kit Assembly (*)	13.	18-388	Fan Motor Bracket
6.	18-325	Motor Compressor 115/60/1	NOTE: Overload Not Used On Units That Are Inherent Protected. If Possible Use Copeland Part No. When Ordering Capacitors & Relays		
7.	18-347	Overload Klixon (*)	(*) Not Shown		
8.	18-241	Terminal Assembly (*)			

MAINTENANCE INSTRUCTIONS

The following services must be accomplished in a minimum of two (2) times per year on all Icemakers.

1. Check and clean water strainers and float valves. Depress float valve to insure full stream of water.
2. Check water level and machine level. Keep water level below overflow but as high as possible and still not run out of spout opening with machine off. Water should come out of spout with ice at all times. Adjust as required.
3. Clean reservoir and interior of freezer assembly using Ice Machine Cleaner.
 - A.
 1. Set main switch to OFF.
 2. Remove all ice from storage bin.
 3. Turn off water supply or block float. Drain reservoir by removing overflow tube (gray plastic tube) in reservoir. Replace overflow tube.
 4. Set main switch to ON and pour cleaning solution into reservoir. Do not fill above overflow tube. Models SF2 & SF3 -- Use 6 oz. of Scotsman cleaner and 1 1/2 qt. hot water.
 5. Continue to make ice on solution until the solution is used up and reservoir is empty.
 6. Set main switch to OFF. Remove overflow tube, wash and rinse reservoir, replace overflow tube, turn water on or remove float block.
 7. Turn MAIN SWITCH to ON. Let unit run for at least (15) minutes to flush out any cleaning fluid. Check ice for acid taste -- run until ice tastes sweet.
 8. Turn MAIN SWITCH to OFF. Add hot water to ice bin, using this melt water, thoroughly wash and and rinse all surfaces within the storage bin.
 9. Turn MAIN SWITCH to ON. Replace Service Door. Unit is ready for normal operation.
 - B. If heavy mineral deposits on auger and walls, or sediment at inlet to freezer are encountered, clean by pouring strong solution (1/2 acid - 1/2 water) into reservoir and operate drive motor only for agitation. Allow 1/2 hour or longer as required. Drain by disconnecting tygon at water inlet to freezer.

Note: Cleaning requirements vary according to local water conditions. Visual inspection of the auger before and after cleaning will indicate best procedure to be followed in local areas.

4. Check high and low side pressures. On air cooled models set high pressure between 130 and 145 PSI. On water cooled models, set pressure at 130 PSI. Suction pressure should be above 12 PSI and will range up to 16 PSI depending upon ambient and water temperatures.
5. Set hand reset low pressure control to cut off in event of water supply interruption or low ambient temperature at approximately 5 PSI.
6. Change oil in gear reducer. Use 600W. Grease with BRB No. 1 or equivalent when grease fittings are evident. Particularly important when there is evidence that water has gotten into gear housing. Remove gear reducer to facilitate.
7. Oil drive motor. Use SAE 20 oil.
8. Check top bearing of freezing tube. Pry upward around edge of stamped brass cap. If moisture is around bearing, wipe up and remove grease. Add new grease. Use lubricate No. 5. To replace cap, insert small wire under cap edge to vent air and remove when cap is on tight.
9. Check and adjust belt tension.
10. Clean air cooled condenser. Inform customer to clean frequently. Always shut off machine when cleaning.
11. Oil condenser fan motor when possible.
12. Check for refrigerant leaks and proper frost line. Should frost out of accumulator approximately two feet.
13. Check for water leaks. Tighten drain line connections. Run water down bin drain line to make sure it is open.
14. Check quality of ice. Ice should be wet when formed but will cure rapidly to normal hardness in the bin.
15. Check thermostat and pressure plate cut off. Micro-switch cuts off only compressor. Bin thermostat should be set at 10° differential and should keep entire machine off at least twenty minutes in high ambients (longer in low) during normal operation. Set cut out at 35°, cut in 45°.

If unit is to be operated in an excessively low ambient a head pressure control kit should be added. Scotsman part no. A-18271-1.

This kit consists of a reverse acting hi-pressure control connected electrically to the fan motor. As the head pressure drops below the cut in setting the control opens allowing the current to pass thru a resistor in the line feeding the fan motor. This slows the shaded pole motor down to approximately 1/4 speed thus increasing the head pressure. When the control cuts in the full voltage again flows to the fan motor allowing it to operate at full speed.

SERVICE ANALYSIS

SYMPTOM	POSSIBLE CAUSE	CORRECTION
Unit will not run	<p>Blown fuse</p> <p>Thermostat set too high</p> <p>Loose electrical connection</p> <p>Switch in OFF position</p> <p>Inoperative master switch</p> <p>OFF on the hand reset low pressure control</p>	<p>Replace fuse and check for cause of blown fuse.</p> <p>Adjust thermostat. Set between 35° - 45°.</p> <p>Check wiring</p> <p>Turn switch to ON</p> <p>Replace switch</p> <p>Push hand reset.</p>
Compressor cycles intermittently	<p>Low voltage</p> <p>Dirty condensor</p> <p>Air circulation blocked</p> <p>Non-condensable gases in system</p>	<p>Check for overloading.</p> <p>Clean.</p> <p>Move unit to correct.</p> <p>Purge off.</p>
Making wet ice	<p>Surrounding air temperature above 100° F.</p> <p>Under or over-charge of refrigerant.</p> <p>High water level in water reservoir</p> <p>Faulty compressor valve plate</p>	<p>Correct or move unit to cooler location.</p> <p>Recharge with proper amount.</p> <p>Lower to 1/4 inch below overflow pipe.</p> <p>Repair or replace.</p>
Low ice production	<p>Loss of refrigerant, under or over-charge of refrigerant</p> <p>Dirty or plugged condensor</p> <p>Low water level in water reservoir.</p> <p>Overcharge of oil in system</p> <p>Partial restriction in capillary tube or drier</p> <p>Inlet water strainer partially plugged</p> <p>Corroded or stained worm shafts due to water condition.</p>	<p>Check and recharge with proper amount of refrigerant.</p> <p>Clean condensor</p> <p>Adjust to 1/4 inch below overflow.</p> <p>Check at oil sight glass. Lower to 1/2 sight glass.</p> <p>Moisture in system. Overcharge of oil in system. Remove charge and drier. Replace and recharge system.</p> <p>Remove screen and clean</p> <p>Remove worm shafts and clean.</p>

SERVICE ANALYSIS

SYMPTOM	POSSIBLE CAUSE	CORRECTION
Machine runs but makes no ice	<p>Loss or under-charge of refrigerant</p> <p>Drive motor, gear reducer or drive coupling inoperative</p> <p>Water not entering freezing chamber</p> <p>Moisture in system</p> <p>Water seal leaking</p> <p>Defective manual overload switch</p>	<p>Check for leaks and recharge.</p> <p>Check. Repair or replace.</p> <p>Plugged strainer or supply line. Check and clean. Air lock in gravity feed line. Check and remove air lock.</p> <p>Check and remove charge and drier. Replace and recharge.</p> <p>Replace seal.</p> <p>Replace switch</p>
Water leaks	<p>Defective water seal</p> <p>Gravity feed line leaking</p> <p>Water level in reservoir too high</p>	<p>Replace</p> <p>Check hose clamps.</p> <p>Adjust to 1/4 inch below overflow pipe.</p>
Excessive noise or chattering	<p>Mineral or scale deposit on auger and inner freezing chamber walls</p> <p>Low suction pressure</p> <p>Intermittent water supply</p> <p>Water level in reservoir too low</p> <p>Misaligned drive coupling</p> <p>Gear reducer low on oil charge</p> <p>Gear reducer loose on frame</p> <p>Drive motor end-play or worn bearings</p> <p>Motor compressor not floating on springs</p>	<p>Remove and manually polish auger, sand inner chamber walls of freezer barrel with approx. 100 grit paper. Use vertical strokes. For lighter concentrations use Scotsman Ice Machine Cleaner periodically.</p> <p>Add gas to raise suction pressure. Raise head pressure control setting.</p> <p>Check and clean water strainer. Check gravity feed line for air lock. Remove air lock.</p> <p>Adjust to 1/4 inch below overflow pipe.</p> <p>Repair or replace</p> <p>Check oil level and refill to oil level plug.</p> <p>Tighten</p> <p>Repair or replace</p> <p>Loosen hold-down bolts.</p>
Machine continues to run with full storage bin	Storage bin thermostat not properly set	Reset or replace, 45° in, 35° out.

PARTS LIST

SF-2H

CABINET PARTS	SF-2H	SF-2WSH
Description	Part No.	Part No.
Case Assembly (Less Doors)	A-16077	A-16078
Case Hood Assembly	A-16194	A-15601
Door Slide Assembly	None	A-16208
Sliding Door Assembly	None	A-15559
Left Side Door Assembly	S-6713	S-6713
Rear Door Assembly	A-8741	A-8741
Front Door Assembly	A-15793	A-15793
Top Door Assembly (Hood Side)	A-6530	A-6530
Top Door Assembly (Over Reservoir)	A-7676	A-7676
Moulding Strip 85"	S-6211	None
Moulding Strip 101" Front	None	S-6413
Moulding Strip 42" Rear	None	A-5829
Legs 4 required	A-15803	A-15803
Emblem	15-156	15-156
Plywood Crate	1-648	1-649
Base Trim Strips 2/unit	A-8902-2	None
Ice Storage Tank Assembly	None	A-15774
Leg Levelers	8-522	8-522

Note: For above cabinet parts in stainless steel,
add 'S' as a prefix to above part numbers.

WATER CIRCUIT

Description	Part No.	Part No.
Water Reservoir Assembly	A-8339	A-8339
Reservoir Body	A-13409	A-13409
Stand Pipe Assembly	S-6715	S-6715
Reservoir Cover	A-16012	A-16012
Inlet Valve & Arm Assembly	S-8138	S-8138
Water Deflector	2-1320	2-1320
Rubber Seat	S-6947	S-6947
Water Valve Bracket	A-12869	A-12869
Float Assembly	A-12067	A-12067
Water Supply Strainer	16-162	16-162

PARTS LIST

SF-2H

WATER CIRCUIT	SF-2H	SF-2WSH
Description	Part No.	Part No.
Ice Shortage Tank Drain Assembly, Male	None	A-18090
Drain Assembly Strainer	None	A-6448
'O' Ring	None	2-530
Water-Tygon Tubing		
Reservoir to Freezer		
Per Foot	5-186	5-186
Bin Thermal Bulb Bracket	None	3-1212
Rubber Tubing		
Drip Pan Drain Hose, per foot	13-79	13-79
Fittings and Clamps		
Rubber Tubing Clamp	2-538	2-538
Tygon Tubing Clamp (with 5-186 tube)	None	2-535

FREEZER ASSEMBLY	SF-2H	SF-2WSH
Description	Part No.	
Freezer Assembly	A-6991-3	
Ice Breaker	A-8316	
Worm Shaft	2-617	
Lock Washer	3-679	
Brass Machine Screw	3-732	
Freezer Cap	A-8581	
Freezer Cap Hook	A-8582	
Hex Cap Screw	3-715	
Washer - Over Top Bearing	A-6273	
Top Bearing	2-646	
'O' Ring, Shaft	2-643	
'O' Ring, Cap	2-560	
Retaining Ring	3-712	
Worm Tube, Coil and Housing Assembly	A-6382	
Water Seal Assembly	2-929	
Bottom Bearing	2-619	
Bearing Retainer	A-10591	
Worm Tube Nut	A-6153	
Drip Pan Assembly - Rubber	13-208	
Refrigerant Drier	2-544	

PARTS LIST

ELECTRICAL COMPONENTS		SF-2H SF-2WSH
Description	Part No.	
Manual Overload Switch	See Page 44	
Ranco - Manual Re-set Lo Pressure Control	11-273	
White Rodgers Bin Thermostat	11-99	
Penn Reverse Acting Head Pressure Control - Used on Air Cooled Models only. In kit A-18271-1	11-264	
Lectrohm Resistor	12-474	
CONDENSING UNITS		
Description	Part No.	
Complete Condensing Unit - Air Cooled 115/60/1		
Motor Compressor Only 115/60/1	18-325	
Valve Plate and Gasket Kit	18-326	
Relay	18-1903-4	
Starting Capacitor	18-1901-7	
Condenser Fan Only	18-363	
Condenser Motor Only	18-331-1	
Mounting Bracket, Condenser Fan Motor	18-388	
Air Cooled Condenser	18-334	
Condenser Shroud	A-12111	
Klixon Thermal Overload	18-347	
Electrical Terminal Assembly, Includes three complete terminals & board	18-241	
Complete Condensing Unit - Water Cooled 115/60/1		
Motor Compressor Only 115/60/1	18-355	
Valve Plate and Gasket Kit	18-326	
Cylinder Head	18-329	
Relay (115/60/1)	18-1903-4	
Starting Capacitor (115/60/1)	18-1901-7	
1/2 H.P. Water Cooled Condenser	18-368	
Water Cooled Condenser Gasket - Plain End	18-262	
Water Cooled Condenser Gasket - Manifold End	18-263	
Klixon Thermal Overload 115/60/1	18-347	
Electrical Terminal Assembly, Includes 3 Complete Terminals & Board	18-241	
Compressor to Water Valve Hose Assembly	18-260	
Compressor to Condenser Hose Assembly	18-261	
Water Regulating Valve - Penn	11-198	
Ranco Hi-Lo Dual Pressure Control	11-286	

PARTS LIST

DRIVE ASSEMBLY		SF-2H SF-2WSH
Description	Part No.	
Drive Motor -- 1/4 HP -- 115/60/1	12-864-1	
Drive Motor -- 1/4 HP -- 230/60/1	12-864-2	
Pulley -- 2 1/2"	2-1462	
Pulley -- 8"	2-1463	
V Belt	13-165	
Coupling Half Bottom	S-7716	
Coupling Half Top	A-6165	
Inserts (Coupling)	13-131	
Set Screws (Coupling)	3-384	
Cap Screw (Coupling) (2)	3-206	
Clamp (Coupling) (2)	S-8496	
Rubber Shield	13-152	
Gear Reducer	2-337	
Gear Reducer Repair Kit	A-6398	
Slow Speed Bearing (2)	2-580-26	
High Speed Bearing (2)	2-337-23	
Slow Speed Oil Seal	2-580-24	
High Speed Oil Seal	2-768-20	
High Speed Gasket	2-768-25	
Slow Speed Gasket	2-580-28	
Slow Speed Bronze Worm Gear and Shaft	2-337-20	
High Speed Gear and Shaft	2-337-21	
MISCELLANEOUS		
Description	Part No.	
Ice Machine Cleaner -- Per Case	19-343-1	
Ice Scoops	2-540	
Paint -- touch up cans	10-153	
Gear Reducer Oil -- 600W	19-359	
Upper Bearing Grease -- Lubriplate No. 5	19-309	

OVERLOAD HEATER CHART FOR MANUAL STARTER SWITCH

QUEEN PART NO. 12-530, GE PART NO. CR101H1, QUEEN PART NO. 12-1221 AND WESTINGHOUSE PART NO. MST02SN

Queen Motor No.	Manufacturer	Electrical Characteristics	Manuf. Part No.	Queen Part No. for G.E. Overload	Manuf. Part No.	Queen Part No. For Westinghouse Overload	Manuf. Part No.
12-864-1	G. E.	115/60/1 1/4 HP	KC35KG312	12-708-29	123H6.25A	12-1221-27	MSH6.0A
12-864-1	Westinghouse	115/60/1 1/4 HP	S309P520	12-708-27	123H5.29A	12-1221-27	MSH6.0A
12-864-1	Century	115/60/1 1/4 HP	CSF48HKA	12-708-26	123H4.86A	12-1221-25	MSH5.0A
12-864-2	G. E.	230/60/1 1/4 HP	KC35KG319	12-708-21	123H3.17A	12-1221-20	MSH3.1A
12-864-2	Westinghouse	230/60/1 1/4 HP	S309P334	12-708-20	123H2.91A	12-1221-19	MSH2.8A
12-864-2	Century	230/60/1 1/4 HP	CSF48HKA	12-708-18	123H2.45A	12-1221-19	MSH2.8A
12-864-7	G. E.	208/60/1 1/4 HP	KC35KG317	12-708-22	123H3.46A	12-1221-21	MSH3.4A
12-864-7	Westinghouse	208/60/1 1/4 HP	S309P334	12-708-19	123H2.67A	12-1221-18	MSH2.5A
12-864-7	Century	208/60/1 1/4 HP	CSF48HKA	12-708-20	123H2.91A	12-1221-19	MSH2.8A
12-649-1	Westinghouse	115/60/1 1/3 HP	311P096	12-708-33	123H8.73A	12-1221-31	MSH8.8A
12-649-1	Century	115/60/1 1/3 HP	CSJ56-KKA	12-708-29	123H6.25A	12-1221-27	MSH6.0A
12-649-1	G. E.	115/60/1 1/3 HP	5KC42JG24	12-708-30	123H6.80A	12-1221-28	MSH6.6A
12-649-2	Westinghouse	230/60/1 1/3 HP	311P061	12-708-25	123H4.46A	12-1221-24	MSH4.5A
12-649-2	Century	230/60/1 1/3 HP	CSJ56-KKA	12-708-21	123H3.17A	12-1221-20	MSH3.1A
12-649-2	G. E.	230/60/1 1/3 HP	5KC42JG2	12-708-22	123H3.46A	12-1221-21	MSH3.4A
12-649-7	Century	208/60/1 1/3 HP	CSJ56-KKA	12-708-22	123H3.46A	12-1221-21	MSH3.4A
12-649-7	G. E.	208/60/1 1/3 HP	5KC42JG31E	12-708-22	123H3.46A	12-1221-21	MSH3.4A
12-649-7	Westinghouse	208/60/1 1/3 HP	311P061	12-708-24	123H4.10A	12-1221-31	MSH8.8A

NOTE: The overloads as listed are in accordance with Underwriters requirements.
Any deviation will be in violation.