

# TABLE OF CONTENTS

Section  
C1-5  
Page 2

FORWORD	1
TABLE OF CONTENTS	2
SPECIFICATION AND DIMENSIONS	3-4
PHOTOGRAPH AND ICE MAKING CHART	5
SELECTING LOCATION	
Location	6
Uncrating	6
Preparation for Installation	6
Setting up Machine	7
Placing Machine Section in Place	7
Installing Crusher	7
Plumbing	7-8
Electrical	8
Start Up	9
Wiring Diagram 230/60/1 AC	10
Wiring Diagram 230/60/1 WC	11
Wiring Diagram 208-220/60/3 AC	12
Wiring Diagram 208-220/60/3 WC	13
Wiring Diagram 208/60/1 AC	14
Wiring Diagram 208/60/1 WC	15
Wiring Diagram C-5B	16
Diagram Plumbing Connections	17
Final Check List	18
CYCLE OF OPERATION	
Harvest Cycle	19
Freezing Cycle	20
SERVICE ANALYSIS CHARTS	21-24
EXPLODED VIEWS OF COMPONENT PARTS	
Sump Pump	25
Control Box	26
Drive Linkage, Spray Bars	27
Front View, Complete Unit	28
Top View, Air Cooled	29
Top View, Water Cooled	30
Air Cooled Case Assy.	31
Water Cooled Case Assy.	32
Hot Water Tank and Water Valve Assy.	33
Spray Bar and Bearing Assy.	34
Drain Valve Assembly	35
SERVICE INFORMATION	
Water Valve Adjustment	36
Miscellaneous Service Information	37
Removing & Replacing Component Parts	38-39
Functional Part & Maintenance	40-45
Maintenance Instructions	46-47
Parts List	48-49

**THIS PAGE  
INTENTIONALLY  
LEFT BLANK**

**THIS PAGE  
INTENTIONALLY  
LEFT BLANK**

SPECIFICATIONS

	SC-500H	SC-500WH
Compressor	1 1/2 hp twin cylinder Semi Hermetic	1 hp twin cylinder Semi Hermetic
Condenser	Cleanable Air Cooled	Cleanable Water Cooled
Refrigerant	R12	R12
Refrigerant Charge	53 ounces	51 ounces
Refrigerant Control	Twin Capillary Tube	Twin Capillary Tube
Power Consumption	10 Amp., 3 Wire 230 V., 60 Cycle Single Phase	10 Amp., 3 Wire 230 V., 60 Cycle Single Phase
Water Consumption to Produce Ice	4 1/2 Gallons per hour	4 1/2 Gallons per hour
Water Used by Condenser		1 to 3 1/2 Gallons per minute. Varies with water temperature.
Ice Capacity	See Chart. Page 5	See Chart. Page 5
Companion Bins	B-400 B-650 B-1250	Same Same Same
Cube Size	Scotsman Super cube	Same
Cubes Per Harvest	160	160

Note: All Scotsman Super Cubers require neutral wire for secondary 115 volt component circuit: 3 phase cubers require 4 wire service with neutral. Special voltages upon request.

# SPECIFICATIONS

SUPER CUBER SC-500 SERIES	MODEL SC-500WH	MODEL SC-500H	MODEL SC-500WH-SS	MODEL SC-500H-SS
Daily capacity up to 500 lbs.	X	X	X	X
400 lb., 650 lb. or 1250 lb. storage unit	X	X	X	X
Air cooled condenser		X		X
Water cooled condenser	X		X	
Heavy duty 1 HP. Compressor	X		X	
Heavy duty 1 1/2 HP. Compressor		X		X
*Standard 115-230 V, 60 cy, 1 ph, 3 wire	X	X	X	X
1/2" water inlet NPT	X	X	X	X
3/4" drip drain NPT	X	X	X	X
1/2" drain on B650H bin NPT				
3/4" sump drain NPT	X	X	X	X
3/4" condenser drain NPT	X		X	
Hammerloid grey exterior	X	X		
Stainless steel exterior			X	X
Stainless steel lined storage bin	X	X	X	X
98 5/8" to 99 3/8" height (with legs) and B650H Bin	X	X	X	X
90 5/8" height (without legs) and B650H Bin	X	X	X	X
42 1/4" width	X	X	X	X
34 1/8" Overall depth including bin (water cooled)	X		X	
39 1/8" Overall depth including bin (air cooled)		X		X
Shipping weight	540	522	546	528

\*Neutral wire required

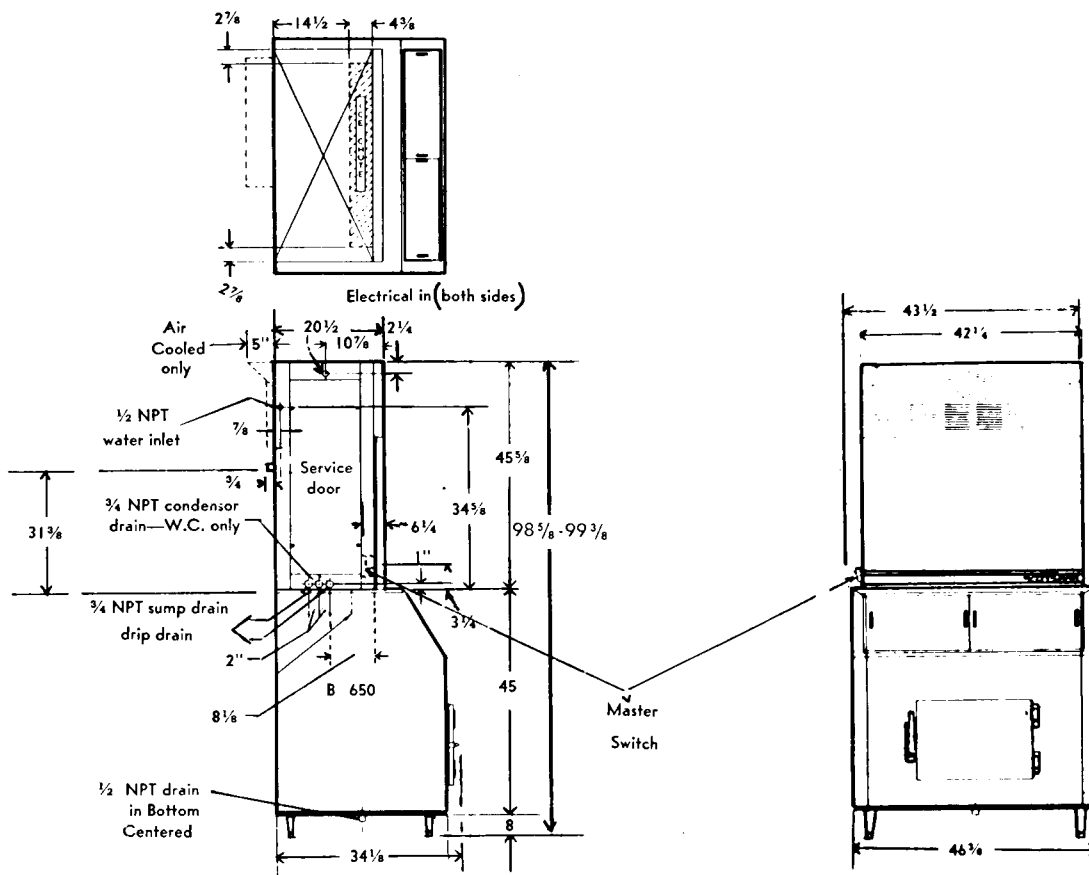

# SCOTSMAN®

Section  
C1-5  
Page 5

## SUPER CUBER SC-500 SERIES

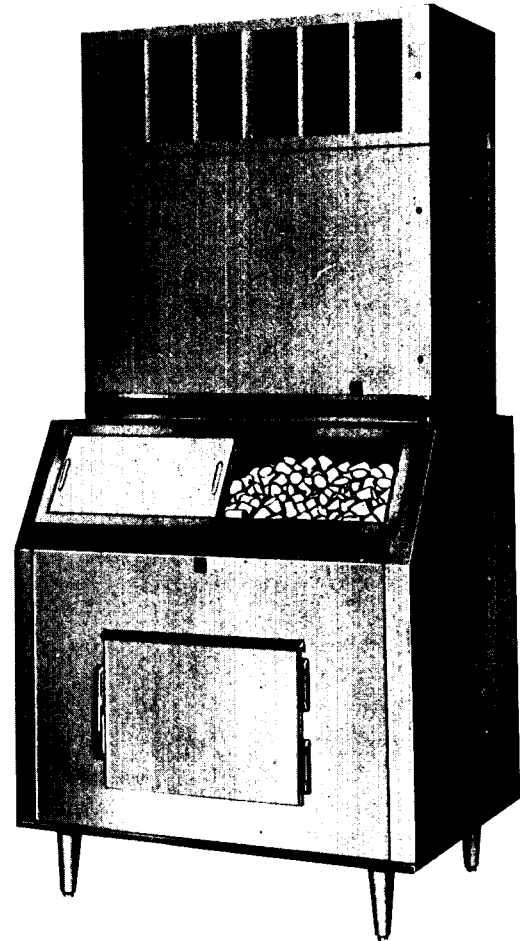

ice making capacity

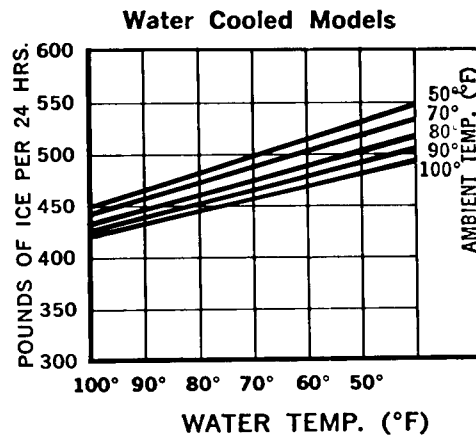
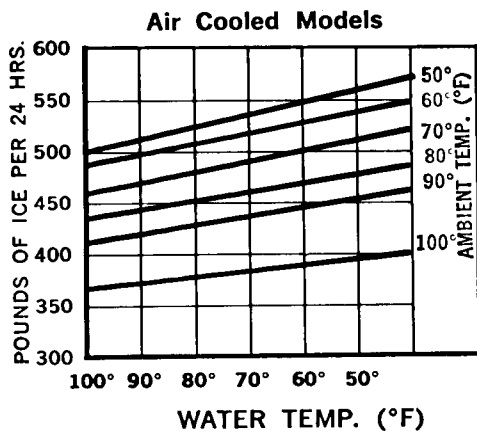

## INSTALLATION

### LOCATION

1. Select a location as convenient as possible for the user.
2. Accessible to the necessary electrical and plumbing connections.
3. If possible, have minimum space of 12 inches above top and from left end panel for service.
4. A minimum of 24 inches for the convenience of the user in front of the machine.
5. Room temperatures -- minimum of 50 degrees, maximum of 100 degrees.

### UNCRATING

1. If possible, do not uncrate until equipment is in permanent location.
2. Storage bin and machine compartments are shipped in separate crates.
3. Remove hold-down bolts from skids.
4. Remove crate in usual manner for wood crating.
5. Remove warranty card and Users manual from storage bin and wipe bin clean with damp cloth.
6. Fill out warranty card completely including model and serial numbers as taken from aluminum plate found behind front service panel and forward to Scotsman factory using self-mailing card.

### PREPARATION FOR INSTALLATION

1. Inspect complete unit cabinetry for shipping damage. Notify carrier of concealed damage claims.
2. Remove all service doors and panels.
3. Remove water reservoir cover and take out paper packing around float ball, make sure plastic overflow standpipe is securely in place. Adjust water level, by bending float arm, to the highest possible elevation without running over overflow standpipe.
4. Remove leg package from bin and install 4 legs in base sockets of bin.
5. Loosen motor compressor hold down nuts until motor compressor rides freely on mounting springs.
6. Remove all masking tape and packing members from curtains and inner cube making compartments. Re-align components such as sump pump or cube racks that may have shifted in transit.
7. Remove water strainer from machine section for installation on unit or in water supply line feeding unit.
8. Open electrical control box and prepare for hook up. Use knock outs, cord connectors, etc. Then check unit nameplate voltage against building source voltage to make sure they correspond. Caution - Improper voltage applied to units will void your warranty protection.

### SETTING UP MACHINE

1. Be sure floor strength is capable of 1,000 pounds in an area of 29 inches by 42 inches.
2. If ceiling height permits, use 6 inch base legs for the storage bin which will make a more convenient height for the user and allow more fall from the storage bin drain.
3. Storage bin must be absolutely level. (This is important).

### PLACING MACHINE SECTION IN POSITION ON ICE STORAGE COMPARTMENT

1. Remove front top service door and large front service door to facilitate handling.
2. Extreme caution must be used to prevent damage to the equipment or injury to the personnel.
3. If at all possible, use Carrying Handles. Have four men available at this installation.
4. If handles are not available, place 2 x 4's or other available shims at all four corners which allows clearance for fingers.
5. Place 2 x 4's lengthwise across storage bin a short distance in from front and back which will allow clearance for fingers when section is set in place.
6. Each man should take a position at corners of machine section using one hand to lift with and other hand to steady machine. (CAUTION--all four men should be instructed to lift together so as not to tip unit over.)
7. After machine is in position on 2 x 4's on bin section, tilt machine forward and backward to remove 2 x 4's.
8. Place machine section in exact position on storage compartment gasket.
9. Bolt two back tie straps to hold machine section in place.

### WHEN INSTALLING C-55H CRUSHER

1. Unpack crusher and check electrical connections to make sure it is in proper running condition.
2. Place crusher in exact position on storage bin.
3. Bolt two back tie straps to hold crusher section in place on bin.
4. Follow steps under paragraph, "Placing Machine Section in position on Ice Storage Compartment."

### PLUMBING

1. Refer to Installation Diagram page 17.
2. Water inlet should be 3/8 inch pipe or larger.
3. Strainer should be installed on outside of machine as close as possible to unit.
4. A shut-off valve either of globe or gate type should be installed next to strainer for convenience of the service man.
5. SC-500 is equipped with three separate drains so as to comply with all plumbing codes. Drain marked drip pan drain is to catch any condensation that may come from the unit and must have fall as it flows by gravity. Bin has own centered, bottom drain.
6. Drain marked sump should be kept 3/4 inch in size with adequate fall which assures complete emptying of the sump tank at the end of the freezing cycle; and also with enough velocity to remove any sediment or solids which may have accumulated from the preceding batch of ice cubes.
7. Storage drain should be connected to open drain.
8. On water cooled models the drain from the condenser has slight pressure. (NOTE: If outlet of connected drain is visible, it is helpful to the service man in checking condenser water valve.)



9. Air cooled models SC-500 do not use condenser drain connection since refrigerant cooling medium is air rather than water.
10. In areas where vast amounts of solids and impurities are present in the water supply, it may be necessary to use some type of filtering equipment on the water that is used in the actual manufacture of the ice and not for the condenser.
11. If above condition is true, it is suggested to disconnect water line from present location in machine compartment and connect it to a 1/4 inch OD copper line which may be run to the filtering equipment. (Note: if water softening equipment is available in building, connect 1/4 inch line in soft water ahead of heater.)
12. For water treatment over and above normal local impurities, consult Service Dept., Scotsman Queen Products, Albert Lea, Minnesota.

### ELECTRICAL

1. IMPORTANT. An ice machine must be connected by a competent electrician.
2. Refer to wiring diagrams, pages 10-15 for proper voltage hookup in accordance with voltage stamped on complete unit serial plate.
3. Compressor motor operates on high voltage only and all component parts operate on 110 volts only. (CAUTION: In areas where a wild phase is present in their system, it must be kept out of component circuit.)  
Note: Part #12-532 Heating Element requires 230V.
4. Electrician should be instructed to install proper disconnect switch of a three pole variety with solid neutral.
5. Select proper amperage load and fuses per diagrams on pages 10-15 whose voltage corresponds to unit voltage.

### MANUAL SWITCH

A manual switch is provided at bottom of left side of icemaker for the convenience of the user when it is desired to shut the unit down for a period of time. When any electrical component parts are being removed or serviced, it is recommended that the line switch be put in the "OFF" position.

### DUAL PRESSURE CONTROL, WATER COOLED UNITS

A high pressure control is provided to shut down the complete unit in case of extremely high head pressures or interrupted water supply. Some models are equipped with a lock-out type, and the unit will remain off until the control is reset manually. (To reset, press down small plunger on top of control.) The high pressure control should be set at 190 pounds.

The low pressure control is provided as an added safety precaution in case of a broken or leaking refrigerant line. This prevents drawing in air or moisture. The setting of the low pressure control should be zero pounds cut-out and 32 pounds cut-in.

START - UP

1. Make sure all service valves on the condensing unit are open and turned as far as possible to the left. Replace the valve caps after checking the valves. All models are shipped with valves open.
2. Make sure that the flow of air is not impeded in any way over condenser on air-cooled models. Keep condenser clean. (Check and clean the condenser monthly).
3. On all water-cooled models, turn on water supply to water-cooled condenser and check for leaks in connections made.
4. Turn on cube supply at hand shut-off valve. Make sure hot water tank fills to proper level, if it does not, adjust level to 1/4" below overflow pipe by bending float rod.
5. NOTE: Unit has built-in flow control set to approximately .4 gallons per minute.
6. Check electrical circuit for proper voltage from building source. Do not connect with other appliances.
7. Remove cover from control box, check for loose or frayed wire, then turn manual switch to "on" position. Note: All "H" models have motor compressor only switch in control box.
8. Turn disc on time clock to the right just far enough for water solenoid valve to energize. Allow clock to take it through harvest cycle. This will be approximately 3 1/2 minutes. (Figures on dial represent minutes).
9. Dial pointer should be set on Number 3 1/2. After the compressor starts, turn the dial completely around and send it through another harvest cycle. Do this several times. This will completely flush machine of any dust that may have accumulated in shipment.
9. After machine has been properly flushed, allow it to go into a freezing cycle-- check for possible water leaks, check sump pump operation--should be running freely. Also note if jet tube travel is correct, and that none of the jets are plugged.
10. Time clock dial does not rotate at the end of the harvest cycle; it is started later by the cube size control located in the control box.
11. Freezing time will be approximately 30 minutes in a 70 degree ambient. (Longer if above, and shorter if below). After 25 minutes of the freezing cycle, check water in float chamber with a thermometer. (Should be approximately 130-140 degrees at this time.) If temperature is not correct adjust thermostat on left side of hot water tank.
12. Watch first harvest and check to make sure that plastic curtains have not been damaged in shipment.
13. Check size of cubes made: If too small after a second complete cycle; adjust cube size control to lower or colder setting.
14. Check texture of cubes made; partially cloudy cubes throughout suggest unit running short of water near end of freezing, or possibly an extremely bad water condition, which would indicate use of filtering or purifying equipment. Contact SCOTSMAN -- Queen Products, Service Department, Albert Lea, Minnesota, for further details.
15. With unit on harvest cycle, take a handful of cubes made and hold on storage bin thermostat cover. Should cut unit off in one to two minutes. Remove ice; unit should cut back on automatically. Thermostat is factory set at 35° out, 39° in.
16. Replace all panels and service doors.

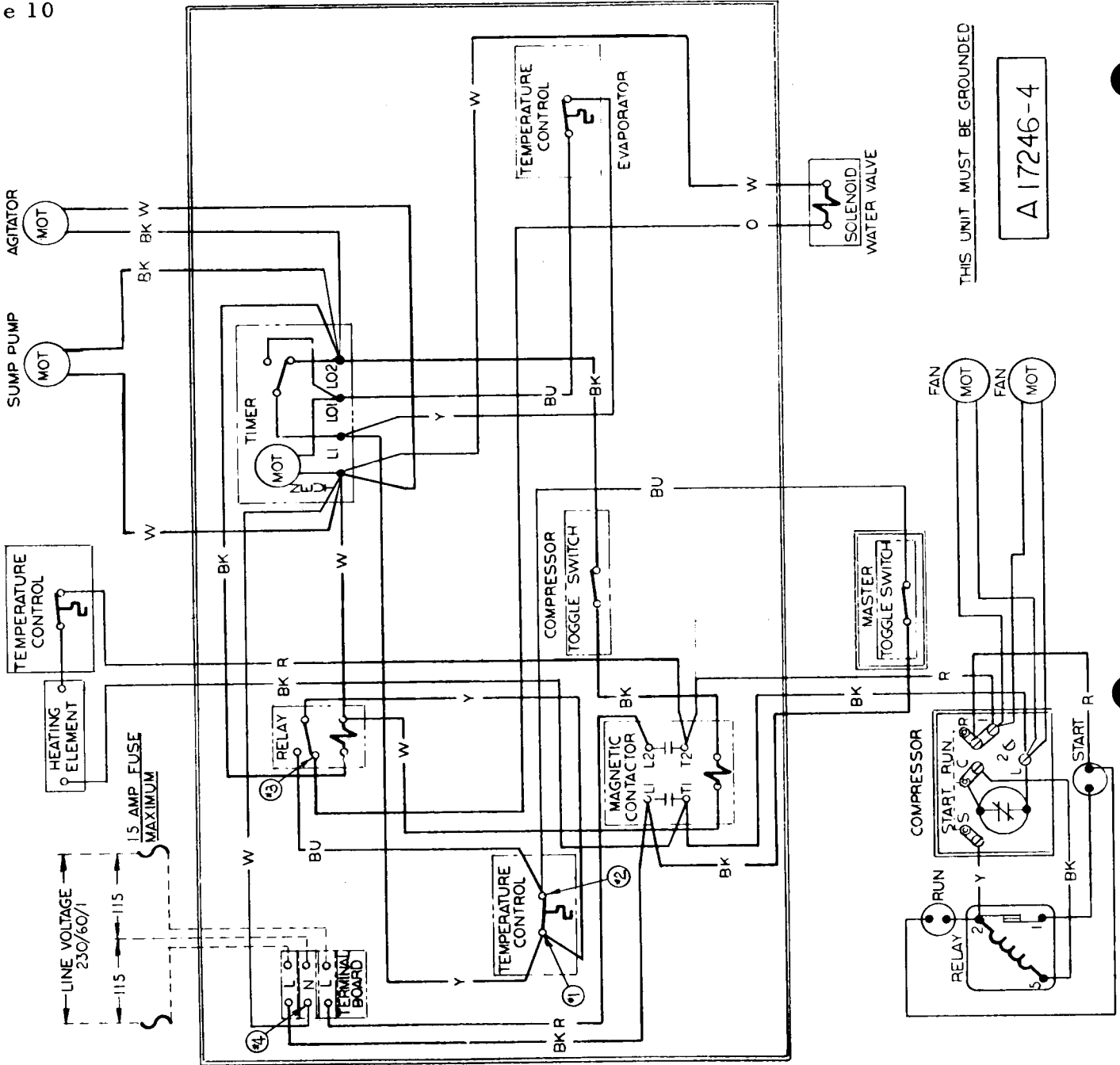

THIS UNIT MUST BE GROUNDED

A17246-4

SC-500  
WIRING DIAGRAM  
230/60/1 AIR COOLED  
A-17246-4

WIRES LEADING FROM CRUSHER ARE TO BE CONNECTED TO TERMINALS IN CRUSHER CONTROL BOX WITH SAME NUMBERS

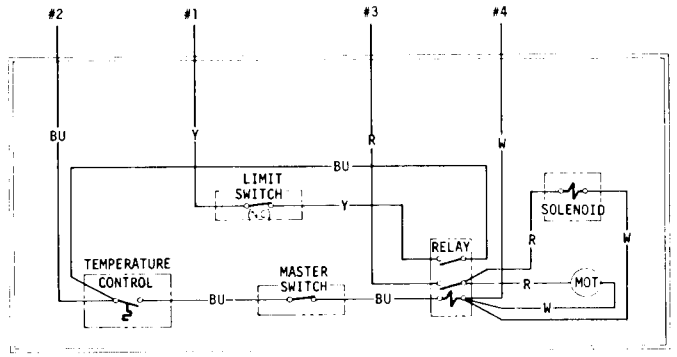

A18880

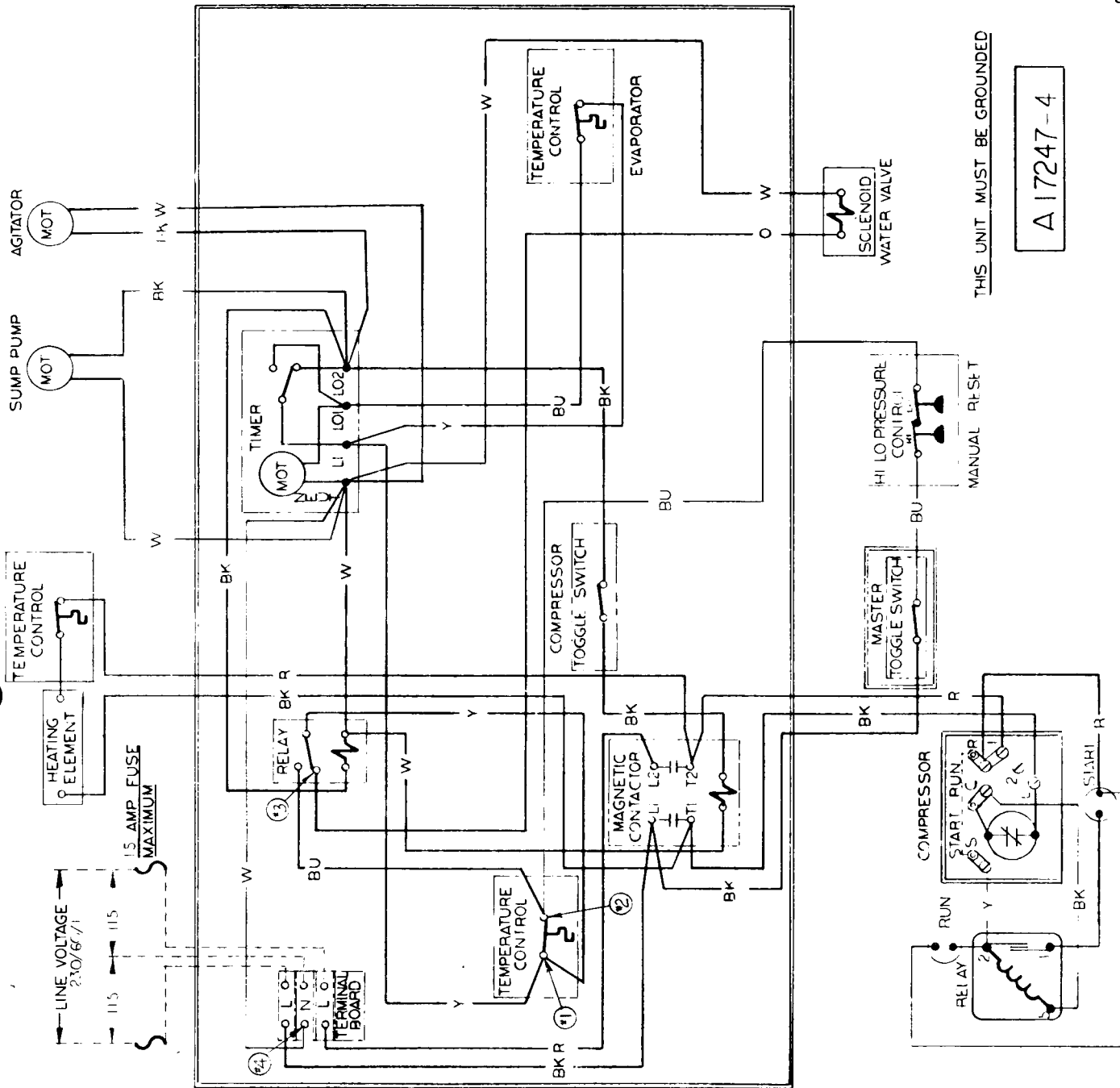

THIS UNIT MUST BE GROUNDED

A 17247-4

SC-500  
WIRING DIAGRAM  
230/60/1 WATER COOLED  
A-17247-4

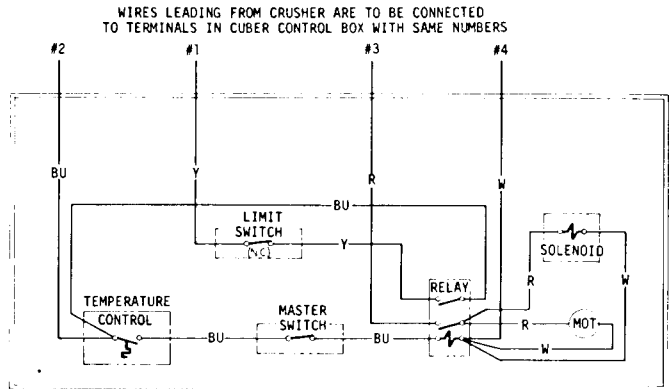

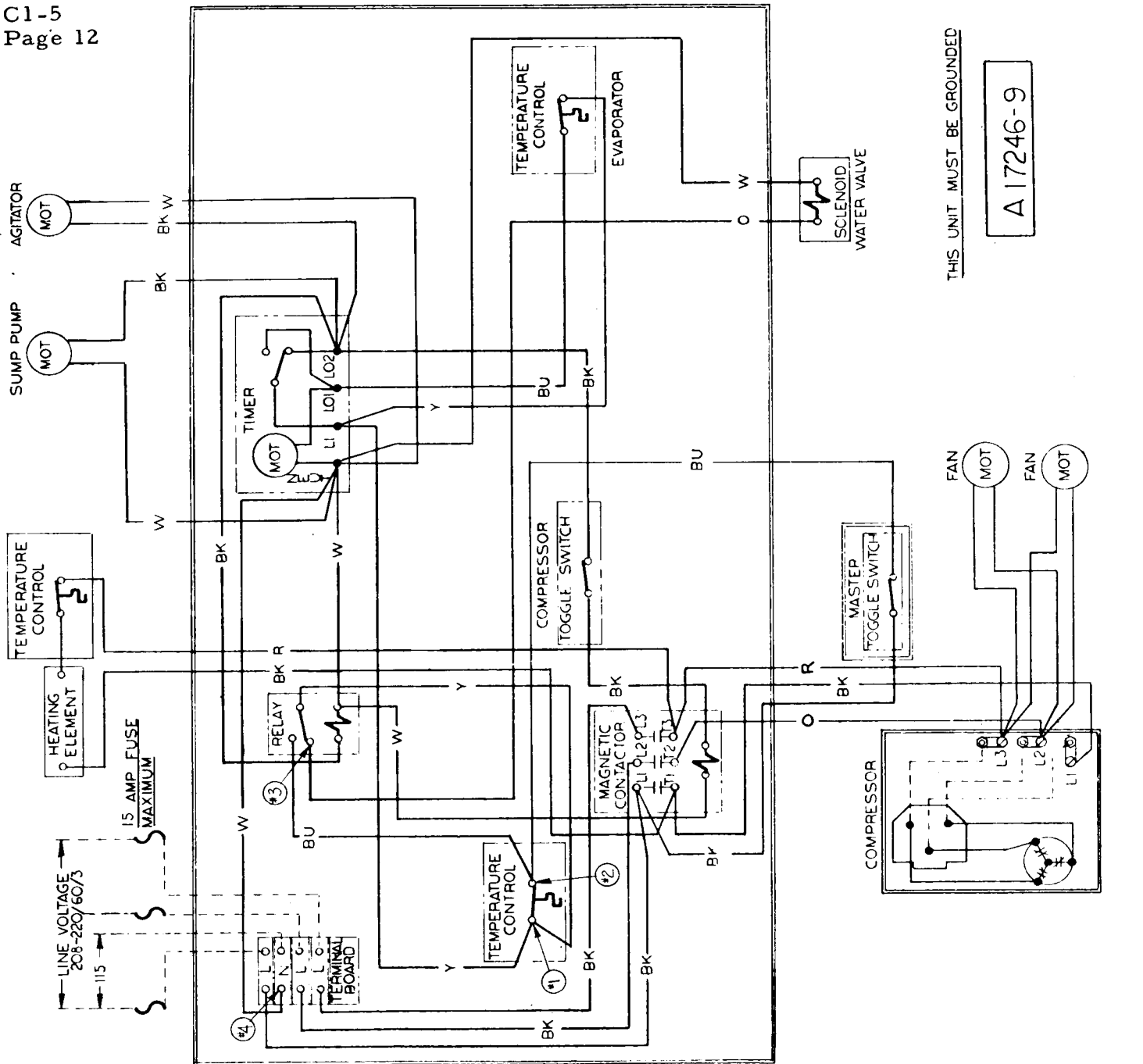

THIS UNIT MUST BE GROUNDED

A 17246-9

SC-500

WIRING DIAGRAM

208/220/60/3 AIR COOLED

A-17246-9

WIRES LEADING FROM CRUSHER ARE TO BE CONNECTED TO TERMINALS IN CRUBER CONTROL BOX WITH SAME NUMBERS

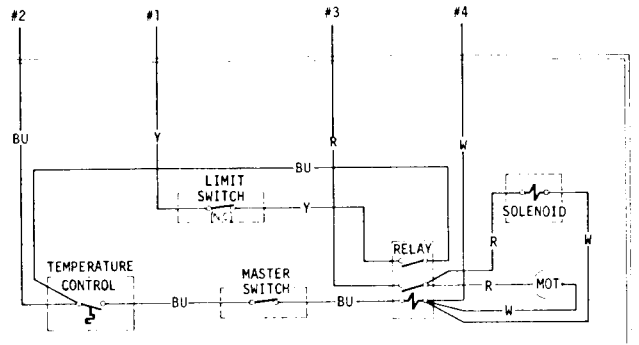

A18880

A 17247-9

THIS UNIT MUST BE GROUNDED

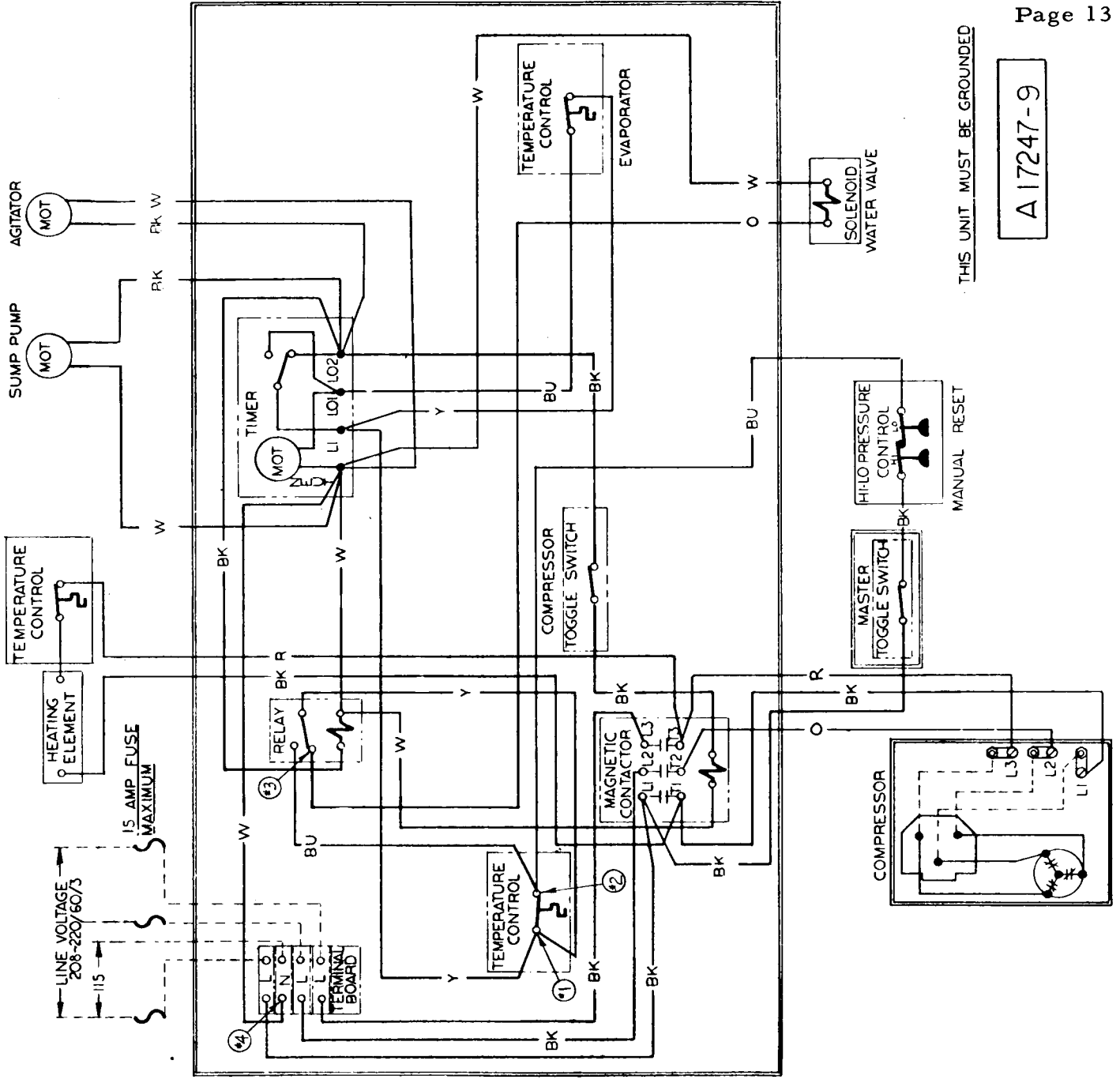

WIRES LEADING FROM CRUSHER ARE TO BE CONNECTED TO TERMINALS IN CUBER CONTROL BOX WITH SAME NUMBERS

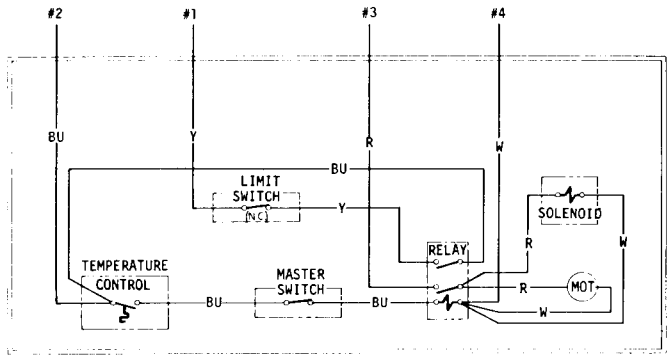

SC-500  
WIRING DIAGRAM  
208/220/60/3 WATER COOLED  
A-17247-9

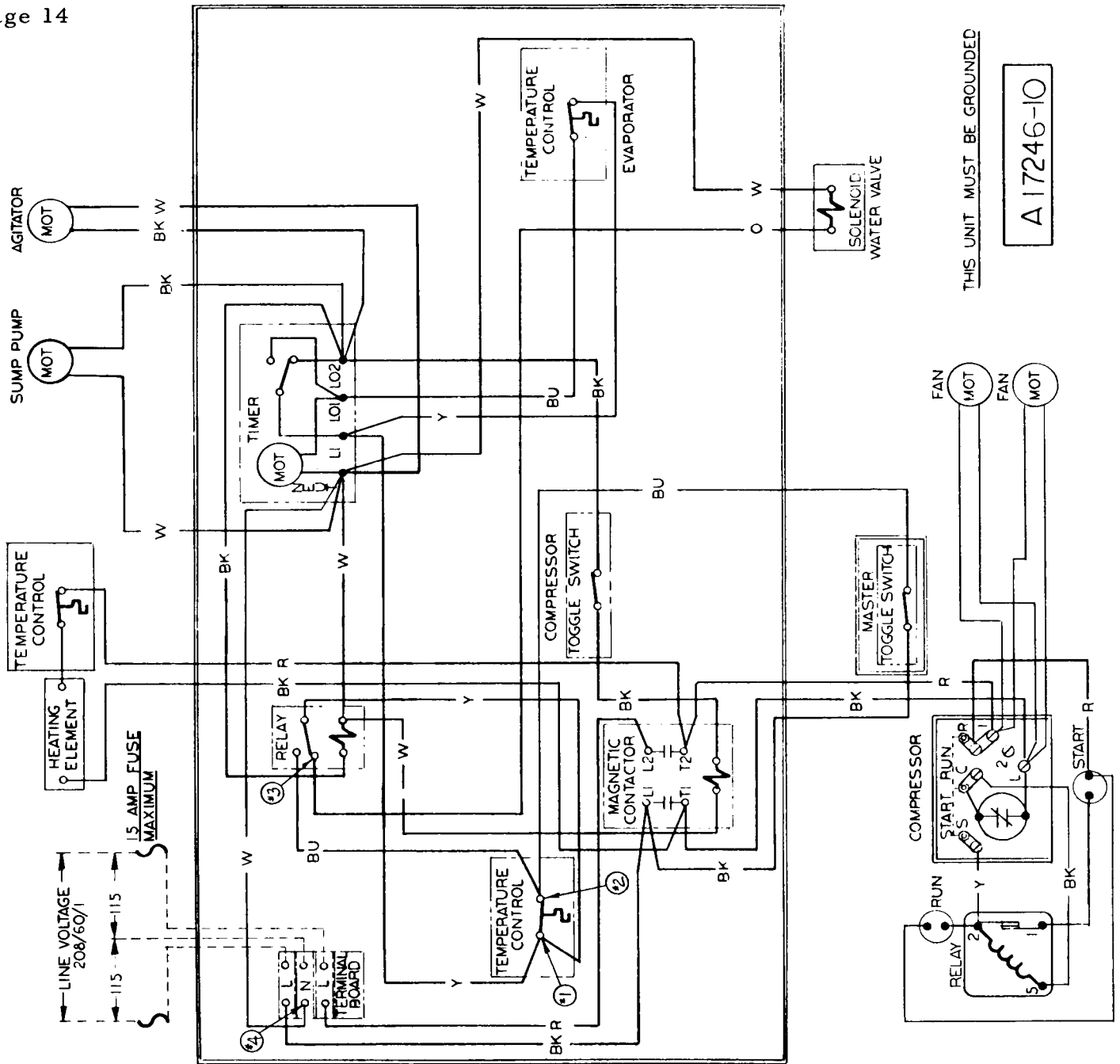

THIS UNIT MUST BE GROUND

A 17246-10

SC-500  
WIRING DIAGRAM  
208/60/1 AIR COOLED  
A-17246-10

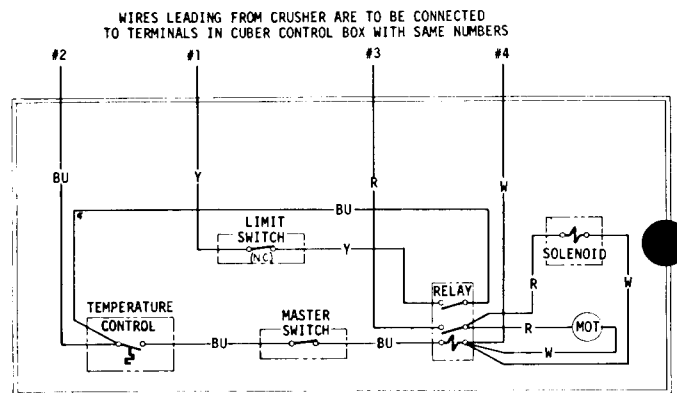

WIRES LEADING FROM CRUSHER ARE TO BE CONNECTED TO TERMINALS IN CUBER CONTROL BOX WITH SAME NUMBERS

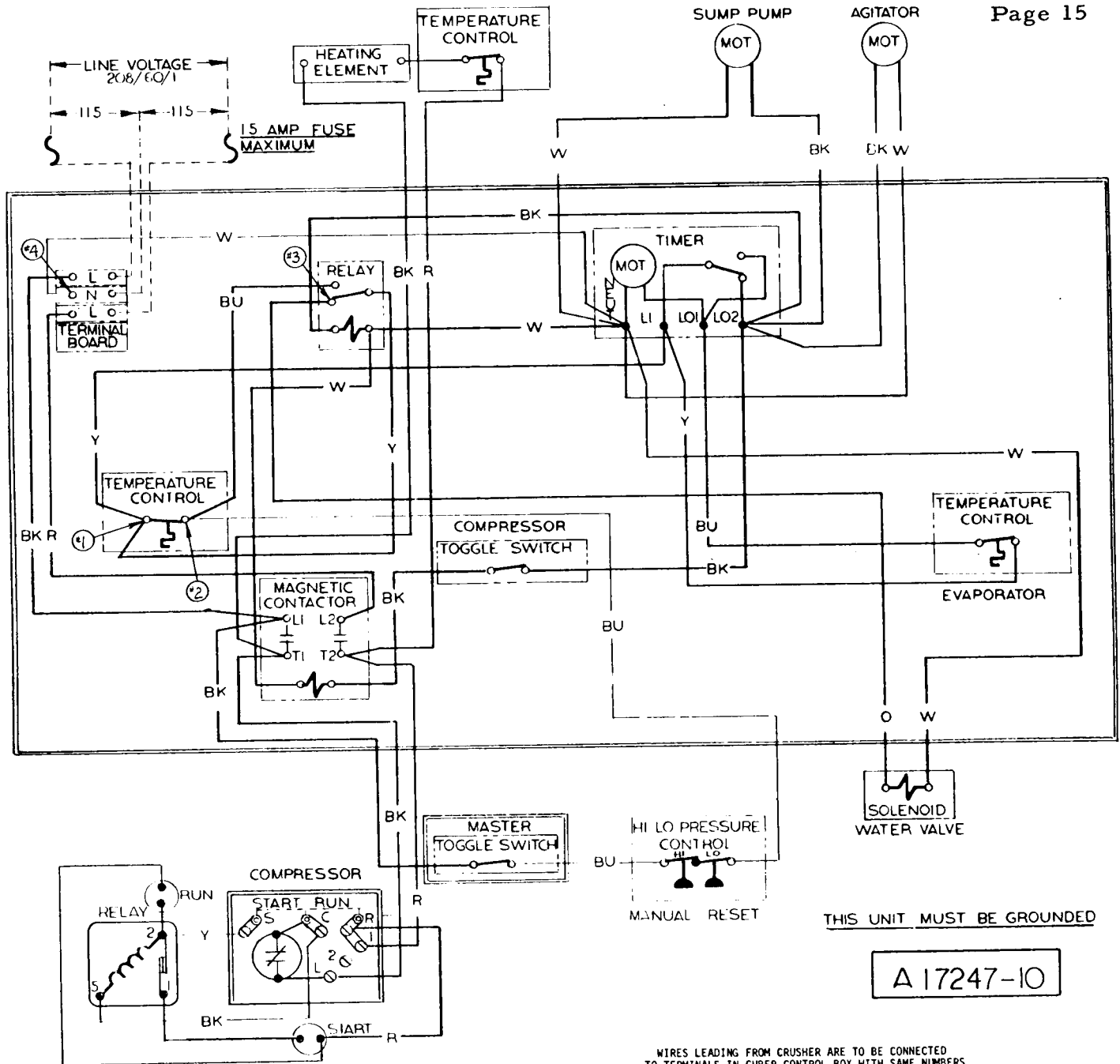

THIS UNIT MUST BE GROUNDED

A 17247-10

SC-500  
WIRING DIAGRAM  
208/60/1 WATER COOLED

A-17247-10

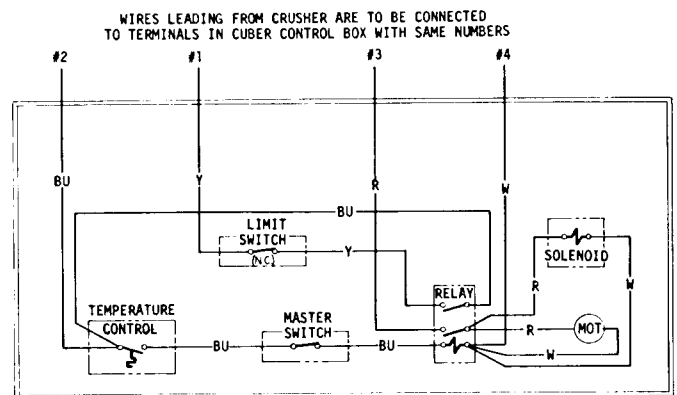

A18880



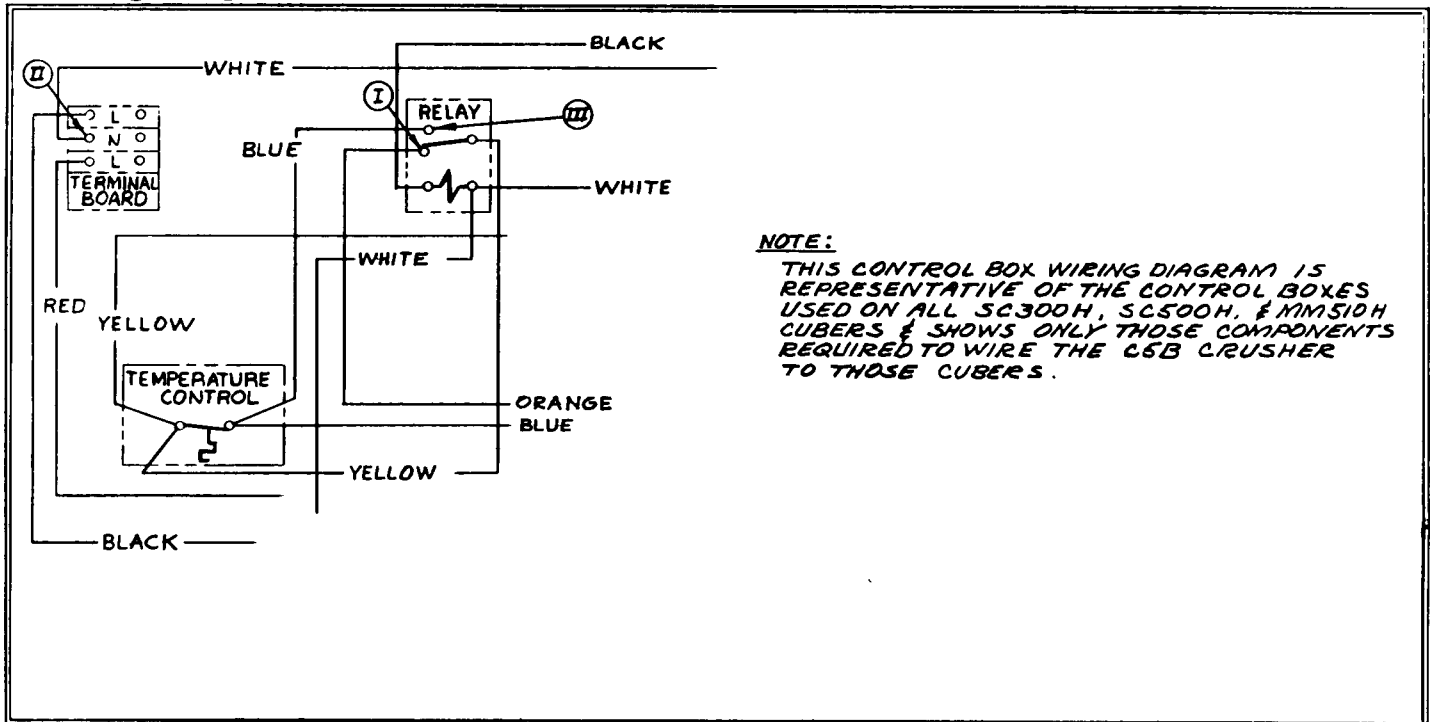
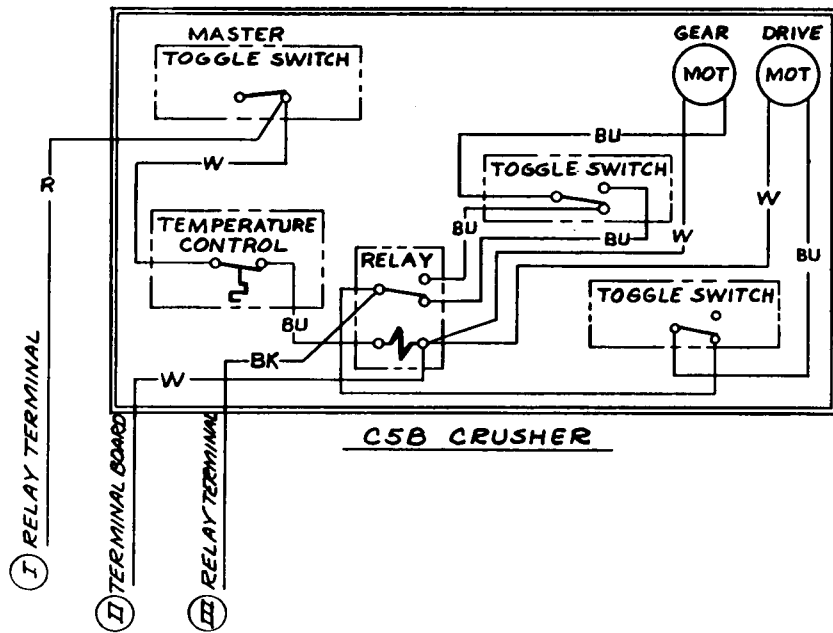

C5B CRUSHER WITH  
 "H" MODEL CUBERS

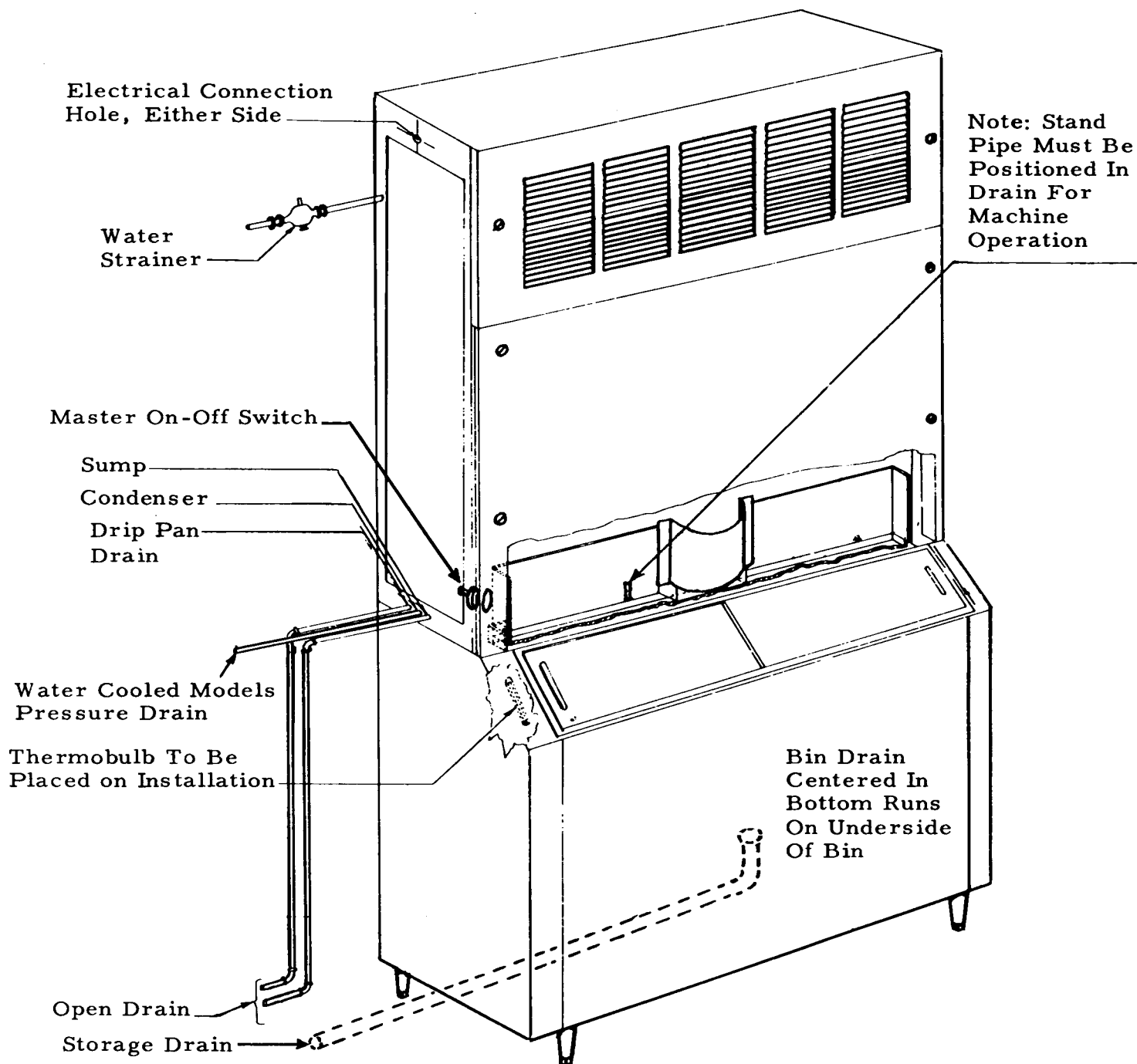

NOTE: Hand shut off valve to be located ahead of water strainer.  
Air cooled models do not use condenser or pressures drain.

SC-500 INSTALLATION  
WITH B-400 SERIES BIN

## INSTALLATION

---

### FINAL CHECK LIST

1. Is the machine level? (Important)
2. Have all electrical and plumbing connections been made and checked?
3. Is the water supply valve open and the electrical power on?
4. Has the voltage been load-tested and checked against nameplate voltage?
5. Have the compressor hold-down bolts been loosened so that the compressor rides freely on its mounting springs?
6. Has float been checked and set in hot water tank for proper water level?
7. Turn machine on and test heater and thermostat. After 25 minutes of freezing cycle, check water in float tank (should be approximately 130 to 140 degrees by this time). If temperature is not correct, adjust thermostat.
8. Operate machine for at least two complete cycles.
9. Is the machine quiet in operation?
10. Have the installation and warranty cards been filled out?
11. Has the owner been instructed on how to operate the machine?
12. Is the machine clean?
13. Check the storage bin thermostat for proper setting of approximately 35 degrees cut out, 39 degrees cut in.
14. Head pressure average 135 # P.S I.
15. Back or suction pressure equalize with head during harvest cycle. During start of freeze cycle starts at about 60# P S I gradually pulls down to 3-5 # P S I end of freezing cycle.

### HARVEST CYCLE

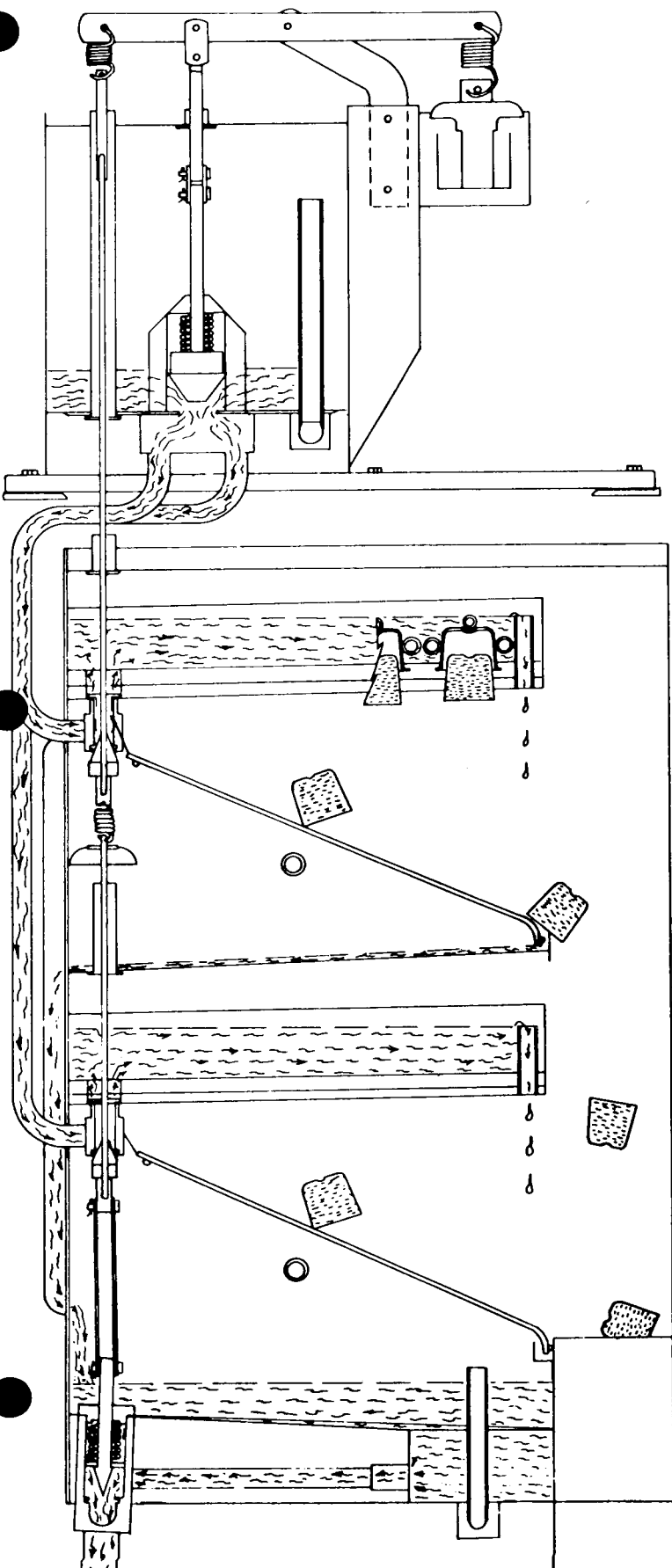

At the end of the freezing cycle the hot water from the water tank flows into the rubber platen holding the cups and by conduction on back of cups causes cubes to defrost. The platen cavity is completely filled up to the overflow point, and continues to overflow while in the defrost cycle; the amount of this water running over the overflow pipe is controlled by the flow control and the length of harvest time setting on the time clock; overflow water goes down the drain also. Meanwhile, cubes being released from the cups drop by gravity onto cube chute, then through curtained opening into storage bin. At completion of harvest cycle, the micro-switch on the timer shaft now drops points holding defrost components in cycle and switches to freezing cycle set of contacts. Clock motor now stops and will not start until cube size control closes once more. The freezing cycle starts and the water valve allows the hot water tank to refill. The chilled water from the upper cavity flows by gravity through the water valve to the sump tank and reservoir. This water is used to produce the next batch of cubes.

### FREEZING CYCLE

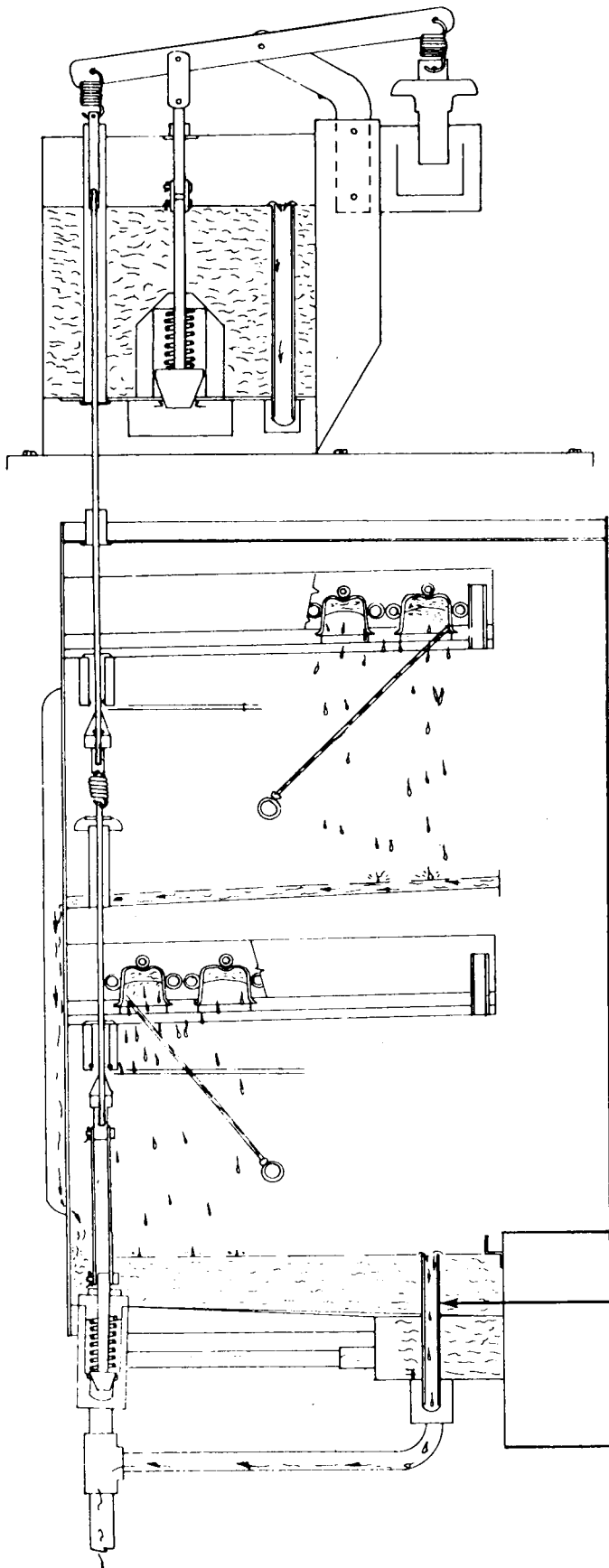

At the start of the freezing cycle, reservoir and sump tank contain enough water to make a complete batch of ice cubes, plus approximately an extra quart. When time clock closes load circuit, it starts the compressor, sump pump and heater element in hot water tank. At the same time it opens the circuit to clock motor. (Clock motor does not run first part of freezing cycle - - this is approximately 8 1/2 minutes) This timer has a single pole, double throw micro-switch for carrying and directing current. After a pre-determined amount of ice is frozen, the cube size or reverse acting temperature switch closes, actuating the time clock motor circuit which continues the freezing cycle approximately 8 1/2 more minutes. (After clock motor starts, freezing time will be 12 minutes less defrost time setting.) At the end of the 8 1/2 minute period, time clock operated switch opens compressor, sump pump and heater element circuit, and closes circuit to time clock motor and solenoid operated water valve. At this time, the water valve allows heated water in hot water tank to flow by gravity through solenoid valve, and into the upper cavity of the freezing chamber, and, at the same time allows the surplus water from the preceding batch of ice cubes to go down the drain.

NOTE: Harvest water is used to make next batch of ice, therefore on initial start up it is necessary to have unit in a harvest cycle. This can be done by manually turning timer dial. Average cycle time is 30-35 minutes.

Stand Pipe

SERVICE ANALYSIS

Symptom	Possible Cause	Suggested Correction
1. Unit will not run.	Power off. Blown fuse.	Check main switch, fuses and wiring
	Manual switch in off position.	Turn manual switch to "on"
	High pressure control locked out.	Reset and check for cause of control off.
	Ambient temperature of room too low.	Must be above 50° Fahrenheit.
	Bin thermostat set too high.	Set approximately 35° cut out, 39° cut in.
2. Compressor cycles intermittently.	Low voltage.	Check with volt meter. Notify power company if 10% over or under nameplate rating.
	Air in system causing high head.	Purge system. Evacuate and re-charge.
	Shortage of refrigerant.	Check frost line, should be cool but not frost on suction service valve.
3. Cubes small. (short cycle)	Cube size control not properly set.	Set control to colder setting
	Moisture in system.	Change dryer and refrigerant.
	Short of water.	Flow control plugged.
		Clean out - install filter in supply line.
	Lower drain valve in sump tank leaking.	Flush or remove and clean. Replace rubber O-ring seat.
	Sump tank stand pipe not properly seated.	Check and re position.
4. Cubes small. (long cycle)	Shortage of refrigerant.	Check frost line and add refrigerant. Refer to nameplate for correct amount of refrigerant.

SERVICE ANALYSIS

Symptom	Possible Cause	Suggested Correction
5. Cubes too large. (slow defrost)	Very small shortage of refrigerant.	Check frost line. Add refrigerant slowly.
	Water valves not holding in hot water tank.	Hold float closed and check during freeze cycle.
	Cube size control set too cold.	Reset to warmer setting on adjustable cam.
6. Cubes cloudy.	Drain valve and sump tank leaking.	Check during freeze cycle.
	Curtains damaged or binding.	Repair or replace.
	Restriction in incoming water.	Check at float in hot water tank and flow control.
	Screen plugged on bottom of sump pump.	Remove and clean.
7. Irregular cubes. (some clear, some cloudy)	Clogged jets in jet tubes.	Remove and clean. Use care not to elongate jet holes
	Cube slides interfering with jets.	Adjust so that jet streams center in cube rack slots.
8. Improper harvest.	Time clock not set properly.	Reset on No. 3 1/2 with adjustable cam.
	Drain valves in hot water tank leaking which prevents water from coming up to temperature.	Inspect and repair. Check rubber O-ring seat under tapered plunger.
	Incoming water restricted.	Check water lines, etc.
	Float valve leaking. (Hot Water Tank)	Check during freeze cycle, float valve should fill tank to 1/2" below overflow pipe then shut water supply off. Replace rubber seat if leak continues.

SERVICE ANALYSIS

Symptom	Possible Cause	Suggested Correction
8. Improper harvest. (Cont'd.)	Stand pipe not properly seated; in hot water tank.	Remove cover and check.
	Machine not level. (Allow water to stand in upper cavities and freeze.)	Level machine.
	Burned out heating element in hot water tank.	Replace.
9. High head pressure.	Over-charge of refrigerant.	Purge.
	Air in system.	Purge.
	Defective water regulating valve.	Replace.
	Burned out or stuck fan motor(s) air cooled.	Replace or oil as needed.
	Water regulating valve improperly adjusted.	Readjust to desired head 135# water cooled models.
	Incoming water restricted.	Check screens, lines, etc.
10. High suction.	Dirty or plugged condenser. Air cooled.	Blow condenser clean.
	Inefficient compressor. valve plate.	Check with gauges and replace if necessary.
	Moisture in refrigerant system.	Purge refrigerant, replace dryer, and re-charge.
	Shortage of refrigerant.	Check frost line, add refrigerant until cool suction service valve is felt.
	Overcharge of refrigerant.	Purge.
11. Low suction pressure.	Moisture in system.	Purge charge, evacuate, replace dryer, and re-charge to nameplate charge.



SERVICE ANALYSIS

Symptom	Possible Cause	Suggested Correction
11. Low Suction pressure. (Cont'd.)	Extreme shortage of refrigerant.	Add refrigerant.
	Ambient temperatures too low. Air cooled.	Increase ambient to minimum 50°F.
12. Water leaking from plastic tubing in upper left hand corner above cube discharge openings.	Float level set too high in hot water tank.	Readjust. Bend float arm to hold water level 1/2" below overflow.
	Float valve leaking.	
	Water-logged float ball.	
13. Unit noisy.	Hold-down bolts on compressor not loosened.	Turn up until unit is free, floating on mounting springs.
	Refrigerant lines vibrating.	Straighten.
	Compressor short of oil.	Check oil level. Proper level 1 1/2 inches below crankcase port or 1/2 of sight glass.
	High head pressures.	Check with gauges. Normal head pressure is 135-150#. Purge if necessary.
	Shroud touching fan blades on air cooled models.	Reposition shroud.

## SC-500 H SUMP PUMP

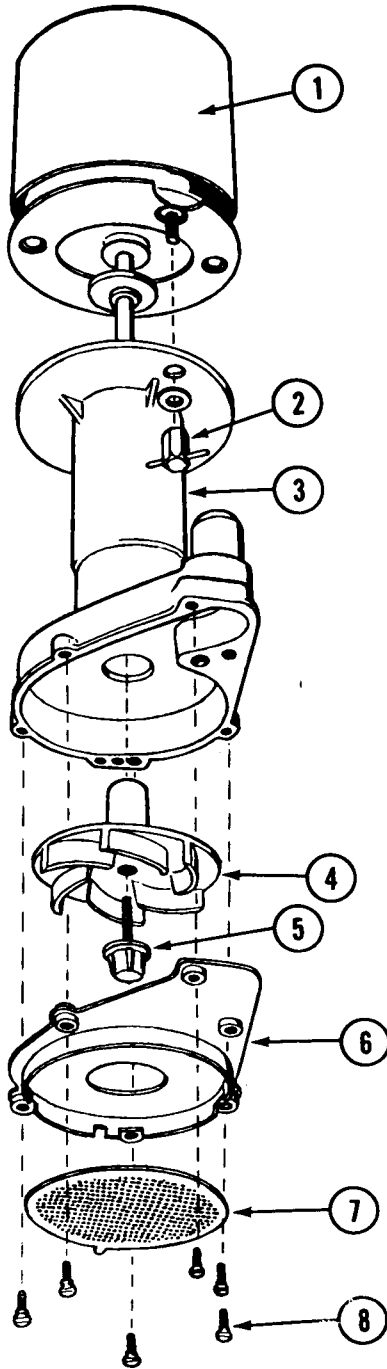

ITEM NO.	PART NO.	NAME
1.	12-1351-22	Motor Only
2.	12-1351-32	Wing Hex Nuts
3.	12-418-30	Pump Body
4.	12-1351-21	Impellar and Spring
5.	12-1351-31	Impellar Screw and Gasket
6.	12-1351-27	Bottom Inlet Plate
7.	12-1351-26	Inlet Screen
8.	12-1351-29	Wing Screws

~~12-418A-1~~ Complete Pump  
 ↙ 12-1701-01

## SC-500 H CONTROL BOX ASSY

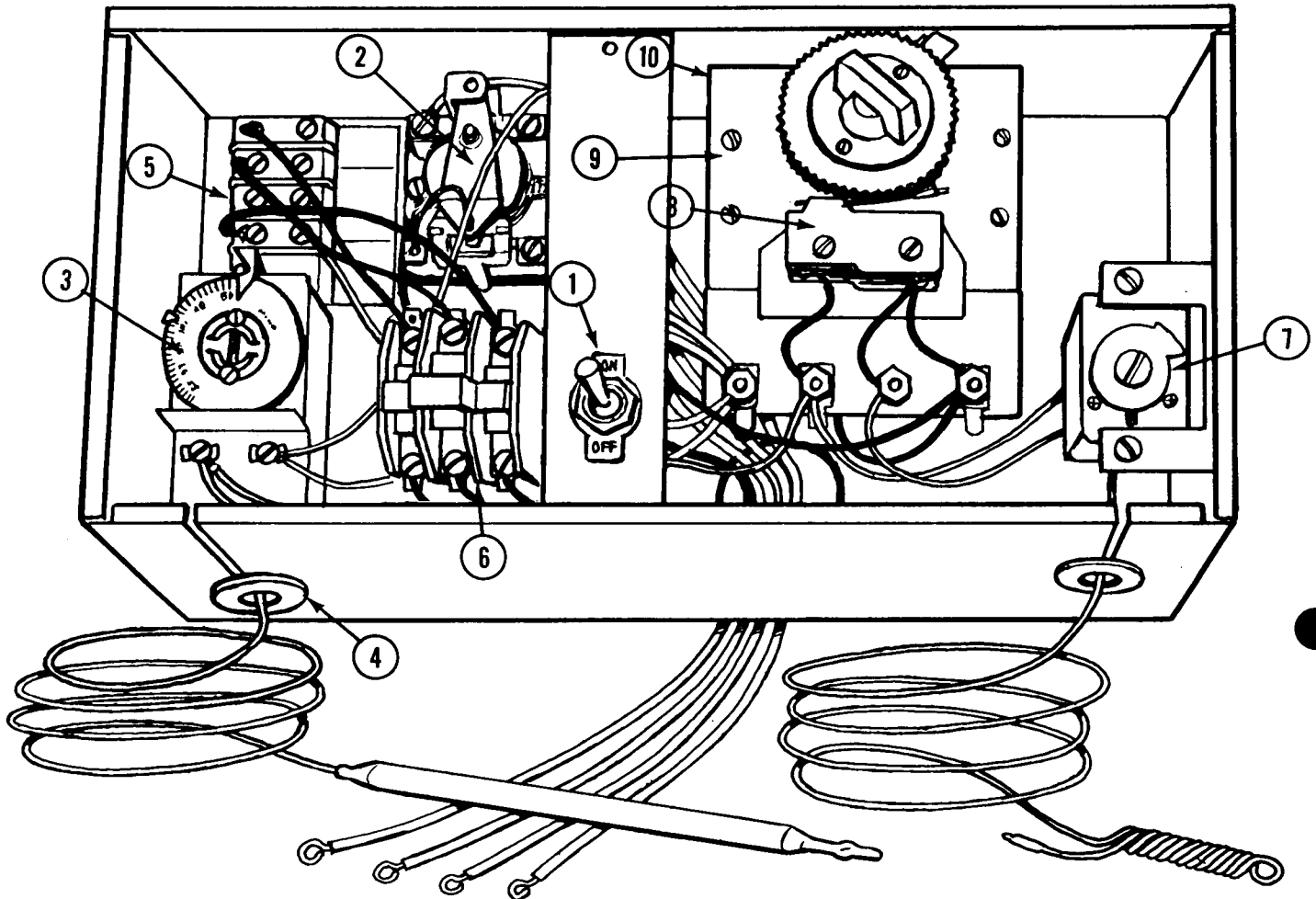

ITEM NO.	PART NO.	NAME
1.	12-426	Switch
2.	12-419	Relay
3.	11-99-1	Bin Control
4.	13-124	Grommets
5.	12-813	Terminal Block
6.	12-820-1	Contactor 115/230/60/1 & 115/208/60/1
	12-739-1	Contactor 115/208-220/60/3
7.	11-345-1	Cube Size Control
8.	12-645-20	Timer Micro Switch only
9.	12-645-1	Timer
10.	12-367	Timer Motor only

## SC-500 DRIVE LINKAGE

"H" Models

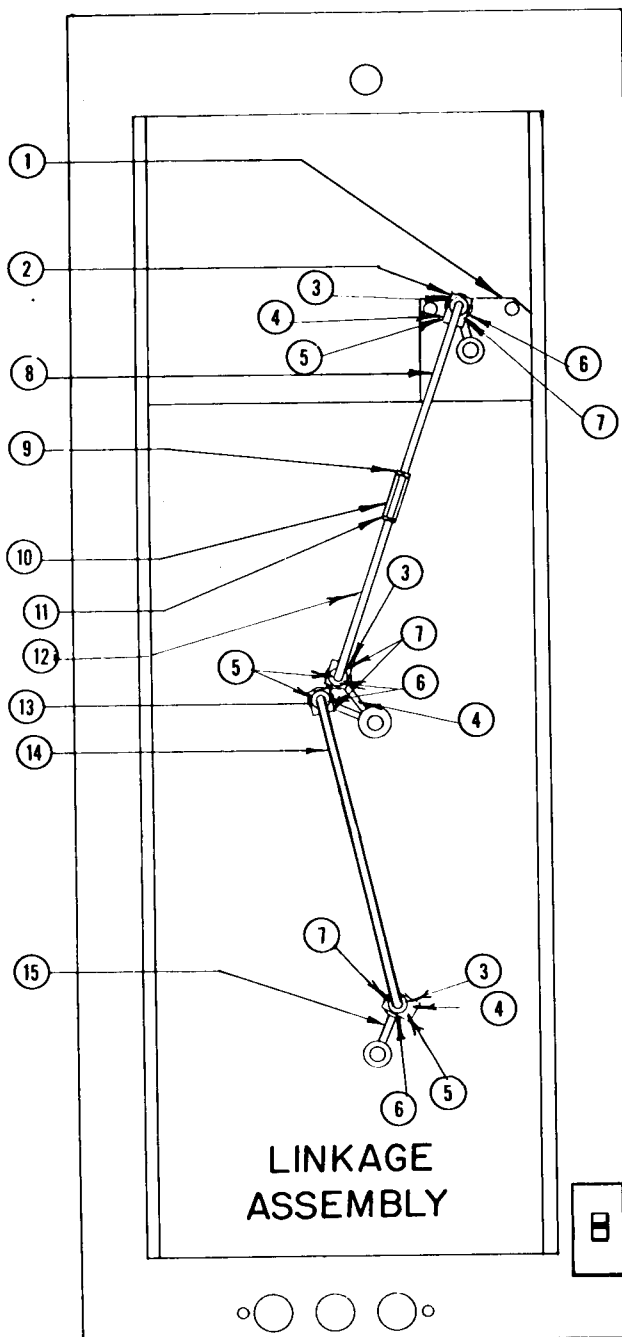

ITEM NO.	PART NO.	NAME
1.	12-446	Drive Motor
- 2.	S-9666	Driver Arm
3.	S-7558	Bearing Clip
4.	3-431	Set Screw
5.	3-75	Washer
6.	3-396-1	Cotter Key S.S.
7.	A-7033	Bearing
8.	S-7940	Upper Linkage (left)
9.	S-7937	Linkage Nut (left)
10.	S-7936	Linkage Coupling
11.	3-357	Nut (Right)
12.	S-7938	Linkage (Right)
- 13.	A-17233	Double Driven Arm
14.	A-17234	Lower Linkage
- 15.	A-17232	Driven Arm
16.	12-426	Switch
	A-17230	Linkage Complete (less Motor)

## SC-500 H AIR and WATER COOLED Front View

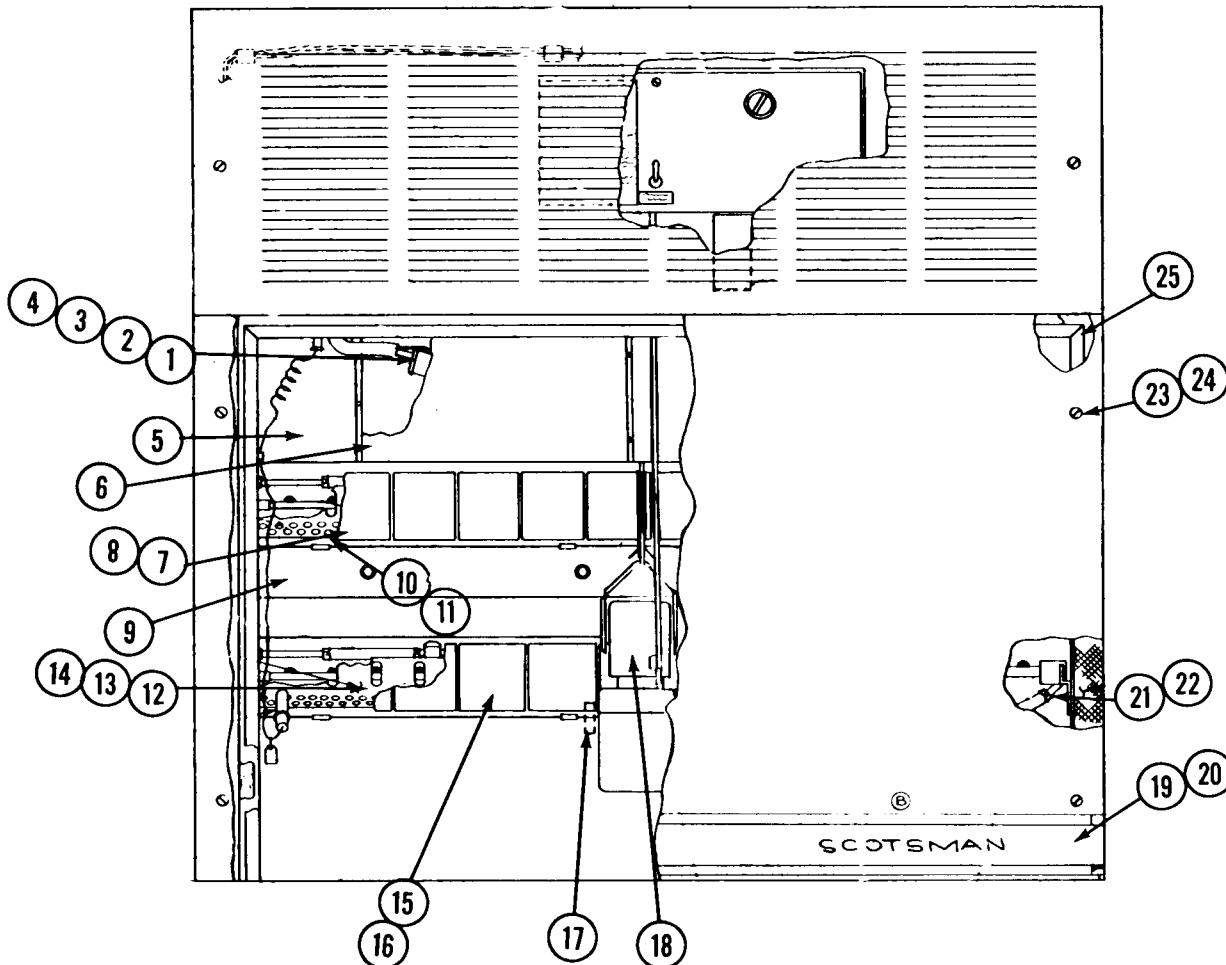

ITEM PART  
NO. NO. NAME

1.	A-18536	Freezer Complete
2.	A-5809-1	Left Cup Ass'y (2 required)
3.	A-5805-1	Right Cup Ass'y (2 required)
4.	13-109-1	Rubber Cup Holder 4 reqd)
5.	A-18311	Upper Face Plate
6.	S-9805	Accumulator Cover
7.	A-17243	Upper Curtain Ass'y
8.	3-727	Thumb Screws (curtain)
9.	A-16662	Lower Face Plate
10.	A-17270	Upper Cube Chute, Right
11.	A-17272	Upper Cube Chute, Left
12.	A-16720	Cube Chute, Right
13.	A-16718	Cube Chute, Left
14.	A-16716	Cube Deflector
15.	A-16778	Left Curtain Ass'y
16.	A-16777	Right Curtain Ass'y
17.	A-17521	Stand Pipe
18.	12-418A-1	Sump Pump
19.	15-474	Emblem Decal
20.	A-5720-9	Moulding Trim (2 required)
21.	2-1338-1	Hose Clamps (6 required)
22.	5-179	Tygon Tube
23.	3-1029	Nut (6 required)
24.	3-789	Screw (6 required)
25.	A-17256	Door Gasket

In Package: A-16108 Buttons  
13-590 Bulb Gasket  
A-15759 Bulb Cover

\*Not Shown

## SC-500 H AIR COOLED

Top View

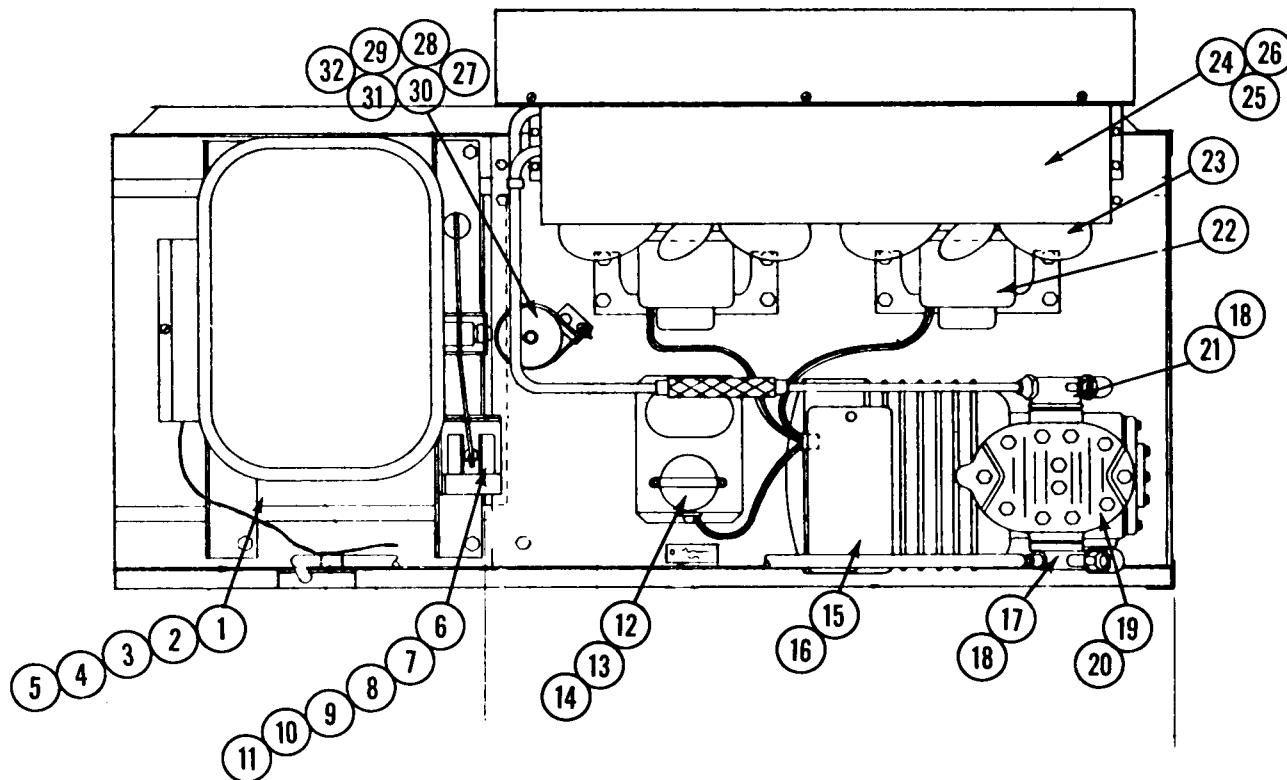

ITEM NO.	PART NO.	NAME
1.	12-446	Drive Motor*
2.	13-100	Grommet (4 required)*
3.	3-50	Screw (4 required)*
4.	3-70	Nut (4 required)*
5.	3-1021	Washer (4 required)*
6.	12-1396-1	Solenoid
7.	A-18276	Solenoid Mount } <i>Bottom Mount.</i>
8.	3-1284	Elastic Stop Nut (4 required)
9.	13-625	Grommet (4 required)
10.	13-298	Washer (4 required)
11.	3-499	Screw (4 required)
12.	18-1901-20	Start Capacitor
13.	18-1902-20	Ron Capacitor
14.	18-1903-22	Relay
15.	18-270	Terminal Board*
16.	18-734	Klixon*
17.	18-561	Suction Service Valve

ITEM NO.	PART NO.	NAME
18.	18-242	Serv. Valve Gasket*
19.	18-621	Compressor 230/60/1
	18-631	Compressor 208/60/1
	18-630	Compressor 208-230/60/1
20.	18-326	Valve Plate & Gasket Kit*
21.	18-1908	Discharge Serv. Valve
22.	18-559	Fan Motor
23.	18-625	Fan Blade
24.	A-17329	Shroud
25.	2-784	Shroud Fastener
26.	18-624	Condensor
27.	3-75	Washer
28.	3-11	Screw
29.	3-60	Nut
30.	2-677	Dryer
31.	A-6355	Dryer Bracket
32.	A-9388	Dryer Brace

\*Not Shown

# SC-500 H WATER COOLED

## Top View

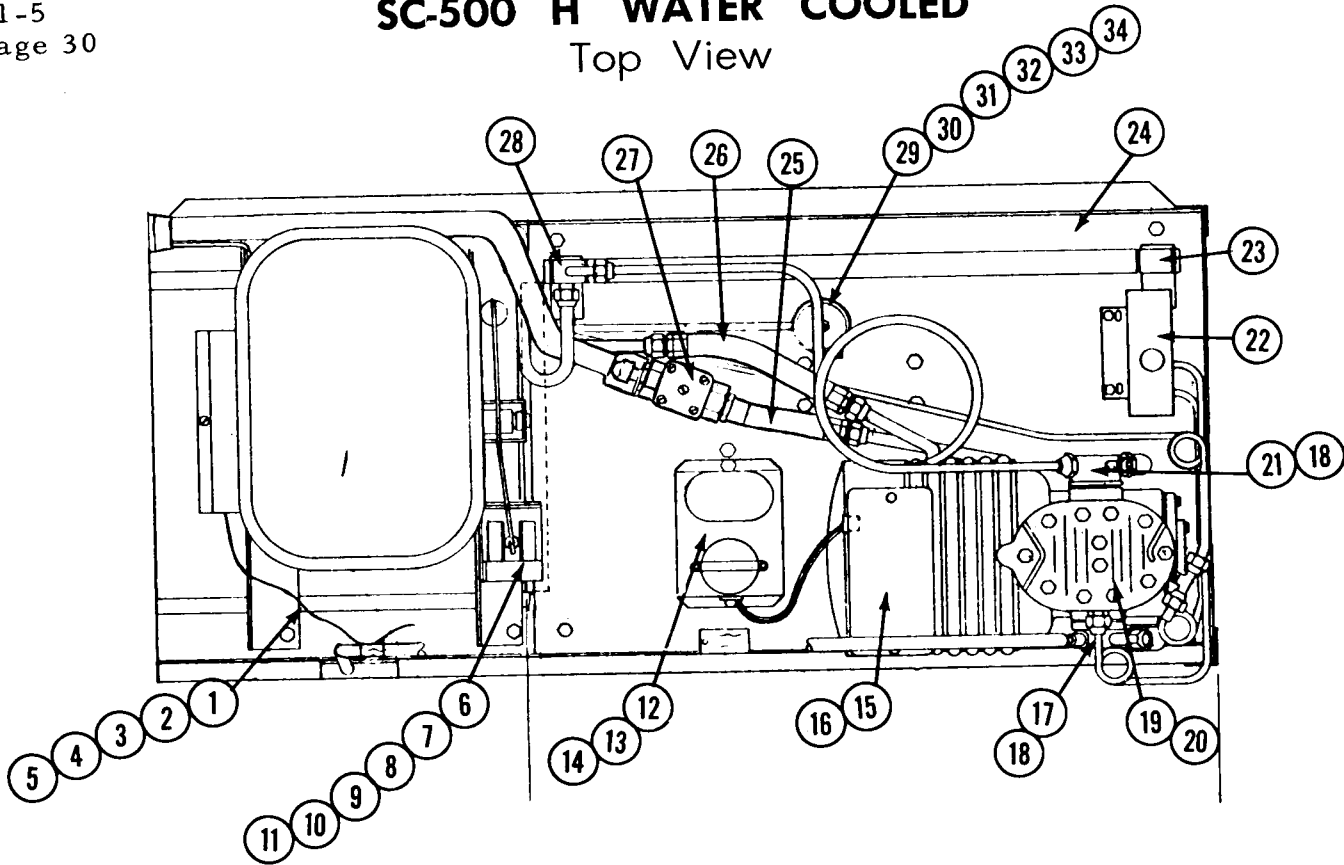

ITEM PART  
NO. NO.

NAME

ITEM NO.	PART NO.	NAME
1.	12-446	Drive Motor*
2.	13-100	Grommet (4 required)*
3.	3-50	Screw (4 required)*
4.	3-70	Nut (4 required)*
5.	3-1021	Washer (4 required)*
6.	12-1396-1	Solenoid
7.	A-18276	Solenoid Mount } <i>Bottom mount.</i>
8.	3-1284	Elastic Stop Nut (4 required)
9.	13-625	Grommet (4 required)
10.	13-298	Washer (4 required)
11.	3-499	Screw (4 required)
12.	18-1901-15	Start Capacitor
13.	18-1902-17	Run Capacitor
14.	18-1903-18	Relay
15.	18-270	Terminal Board*
16.	18-533	Klixon
17.	18-561	Suction Serv. Valve
18.	18-242	Serv. Valve Gasket
19.	18-546	Compressor 230/60/1
	18-571	Compressor 208-220/60/3
	18-550	Compressor 208/60/1
20.	18-326	Valve Plate & Gasket Kit
21.	18-1908	Discharge Serv. Valve
22.	11-286	Hi-Lo Press. Control
23.	18-548	Cond. Gasket
24.	18-599	Condensor
25.	18-260	Flexible Hose
26.	18-261	Flexible Hose
27.	11-198	Water Regulator
28.	18-549	Manifold Gasket
29.	3-75	Washer
30.	3-11	Screw
31.	3-60	Nut
32.	2-677	Dryer
33.	A-6355	Dryer Bracket
34.	A-9388	Dryer Brace

## SC-500 AIR COOLED CASE ASSY "H" Models

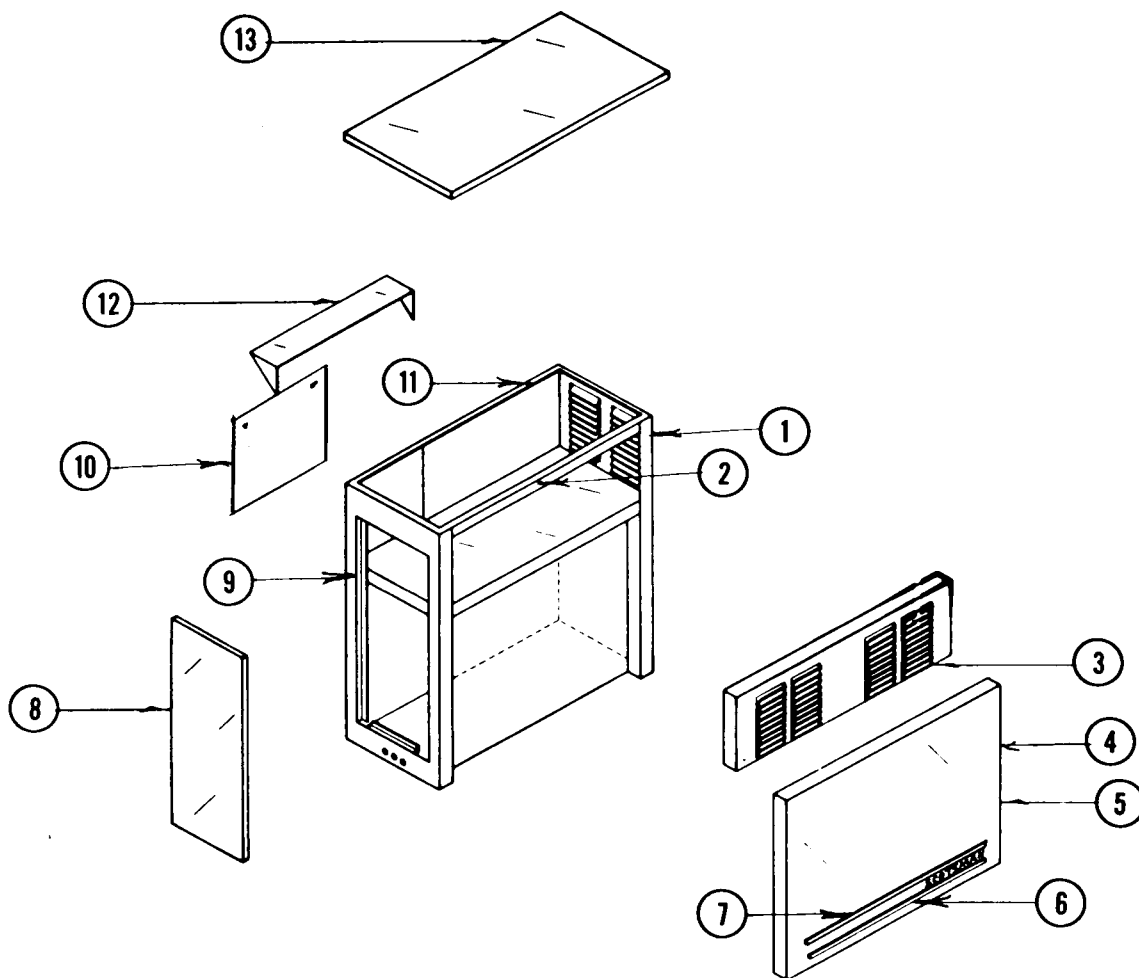

ITEM NO.	PART NO.	NAME
1.	A-8490	Right Side Panel
2.	A-17238	Top Channel
3.	A-16875	Upper Door Front
4.	A-17571	Door Gasket
5.	A-17352	Front Lower Door Assembly Complete
6.	A-5720-9	Moulding Strip
7.	15-474	Emblem Decal
8.	A-17211	Left Side Door
9.	A-17210	Left Side Panel Ass'y
10.	A-8495	Back Assembly
11.	A-8483	Top Back Ass'y
12.	A-8521	Shroud Top
13.	A-5694	Top Panel



## SC-500 WATER COOLED CASE ASSY "H" Models

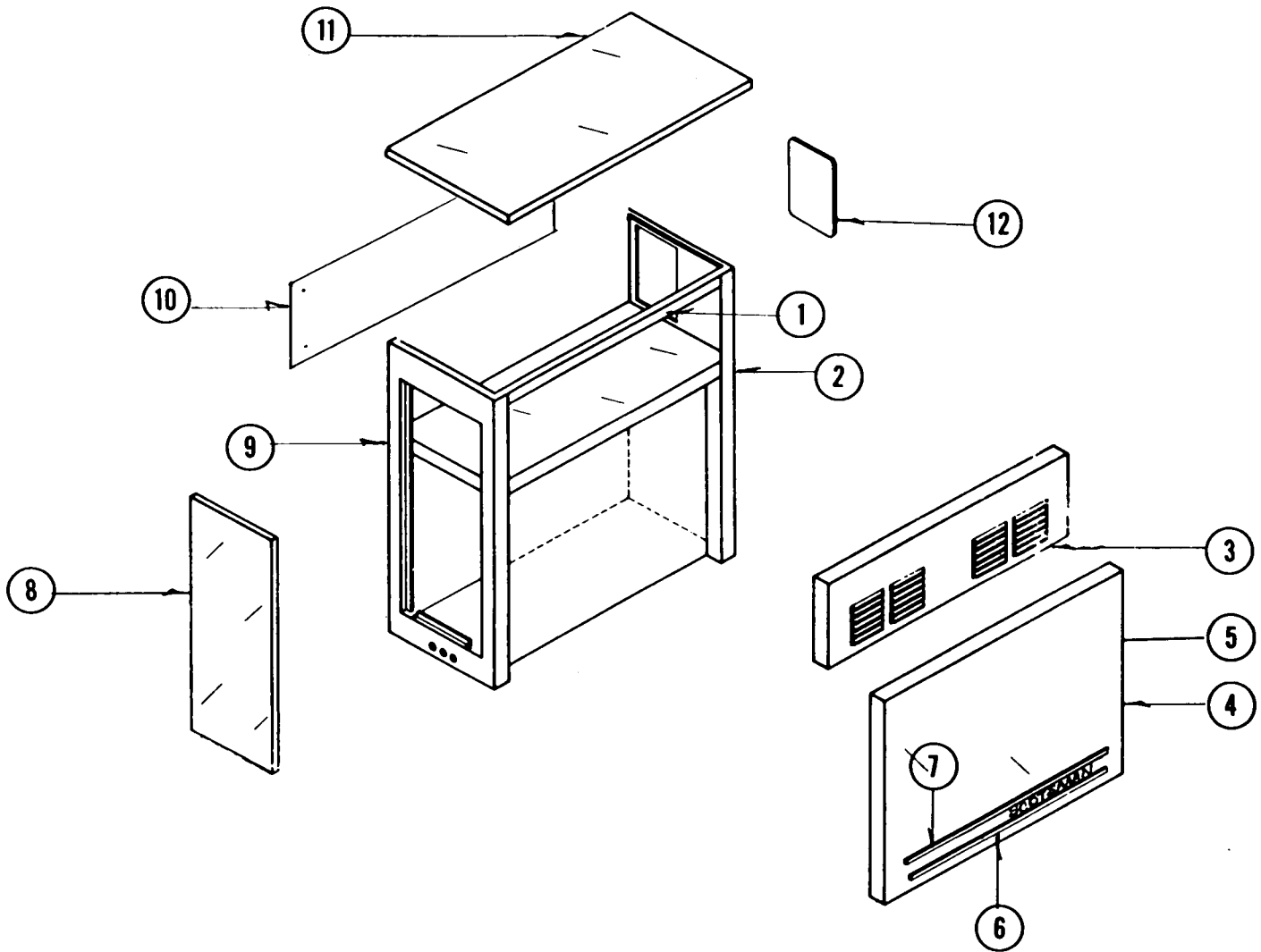

ITEM NO.	PART NO.	NAME
1.	A-17238	Top Channel Ass'y
2.	A-9323	Right Side Panel
3.	A-16875	Upper Door Ass'y (front)
4.	A-17352	Front Lower Door Assembly
5.	A-17571	Door Gasket
6.	A-5720-9	Moulding Strip (2 required)
7.	15-474	Emblem Decal
8.	A-17211	Left Side Door
9.	A-17210	Left Side Panel Ass'y
10.	A-9321	Back Assembly
11.	A-5694	Top Panel
12.	A-5693	Right Side Panel Door

## SC-500 HOT WATER TANK AND WATER VALVE ASSEMBLIES Thru "H" Models

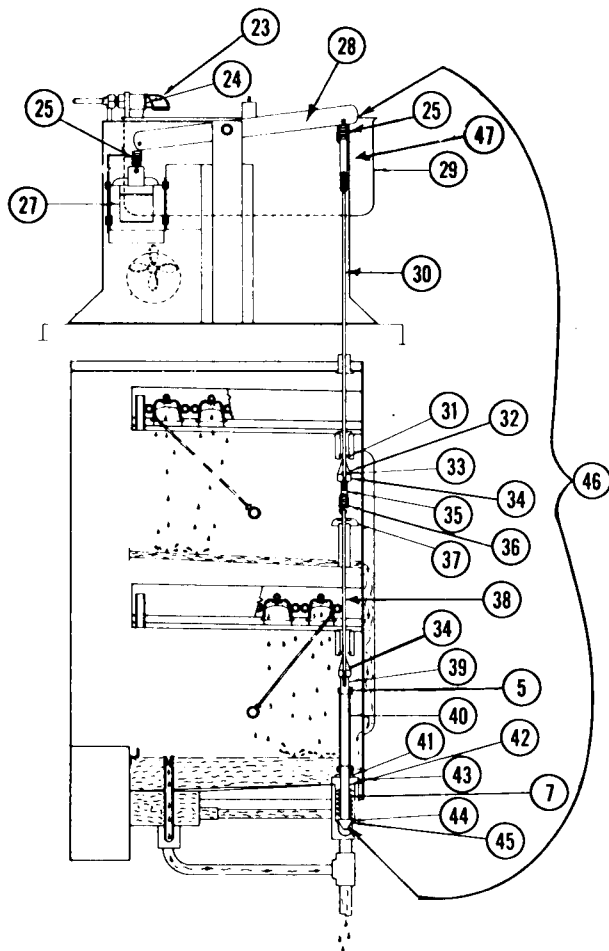
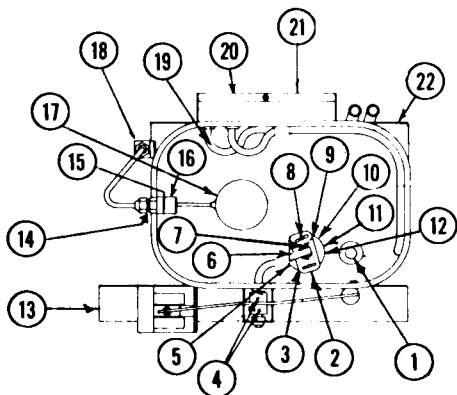

ITEM NO.	PART NO.	NAME
1.	A-8610	Stand Pipe
2.	S-8839	Valve Plunger
3.	A-8188	Plunger Link (SS) (2 reqd.)
4.	3-774	Roll Pins (2 required)
5.	S-7974	Stainless Pins (2 required)
6.	3-396-1	Cotter Pins SS (2 required)
7.	2-419	Compression Spring
8.	3-255	Wing Nuts (2 required)
9.	A-8182	Valve Seat Ass'y
10.	A-8186	Drain Ass'y
11.	2-543	'O' Ring
12.	2-530	'O' Ring (drain ass'y)
13.	A-8175	Right Bracket
14.	A-6771	Water Inlet Valve Ass'y
15.	A-5777	Valve Seat Holder
16.	S-6947	Rubber Valve Seat
17.	A-12068	Float & Arm Ass'y
18.	A-13346-4	Flow Control
19.	12-532	Heating Element
20.	12-246	Thermostat (*)
21.	A-6480	Thermo Disc Cover
22.	A-8173	Left Bracket
23.	2-1320	Plastic Deflector
24.	2-1259	Valve Pin
25.	2-420	Spring
27.	12-1250-1	Solenoid - <i>BOTTOM MOUNT</i>
27.	12-1396-01	Solenoid - <i>SIDE MOUNT</i>
28.	A-8763	Lever Ass'y & Arm
29.	A-8171	Hot Water Tank Sub Ass'y
30.	A-8199	Valve Rod
31.	2-541	'O' Ring
32.	S-8949	Valve Guide
33.	2-545	'O' Ring
34.	S-8948	Lock Nut
35.	S-8946	Valve Nut
36.	2-549	Spring
37.	A-18355	Deflector Ass'y
38.	S-8951	Lower Rod
39.	S-8950	Lower Valve Nut
40.	S-8953	Lower Valve Link (2)
41.	S-8578	Drain Nut Stop
42.	S-8942	Valve Guide Ass'y
43.	S-7891	Nut
44.	S-6924	Valve Seat Washer (2 reqd.)
45.	2-541	'O' Ring
46.	A-8332	Water Valve Linkage Assembly
47.	S-8943	Rod End
48.	A-16378	Drain Screen
	A-17426-1	Hot Water Tank Complete

(\*) Not Shown

\*\*"H" Model use 12-1396-1 Solenoid

## SC-500 SPRAY TUBE AND SPRAY TUBE DRIVE ASSY

"H" Models

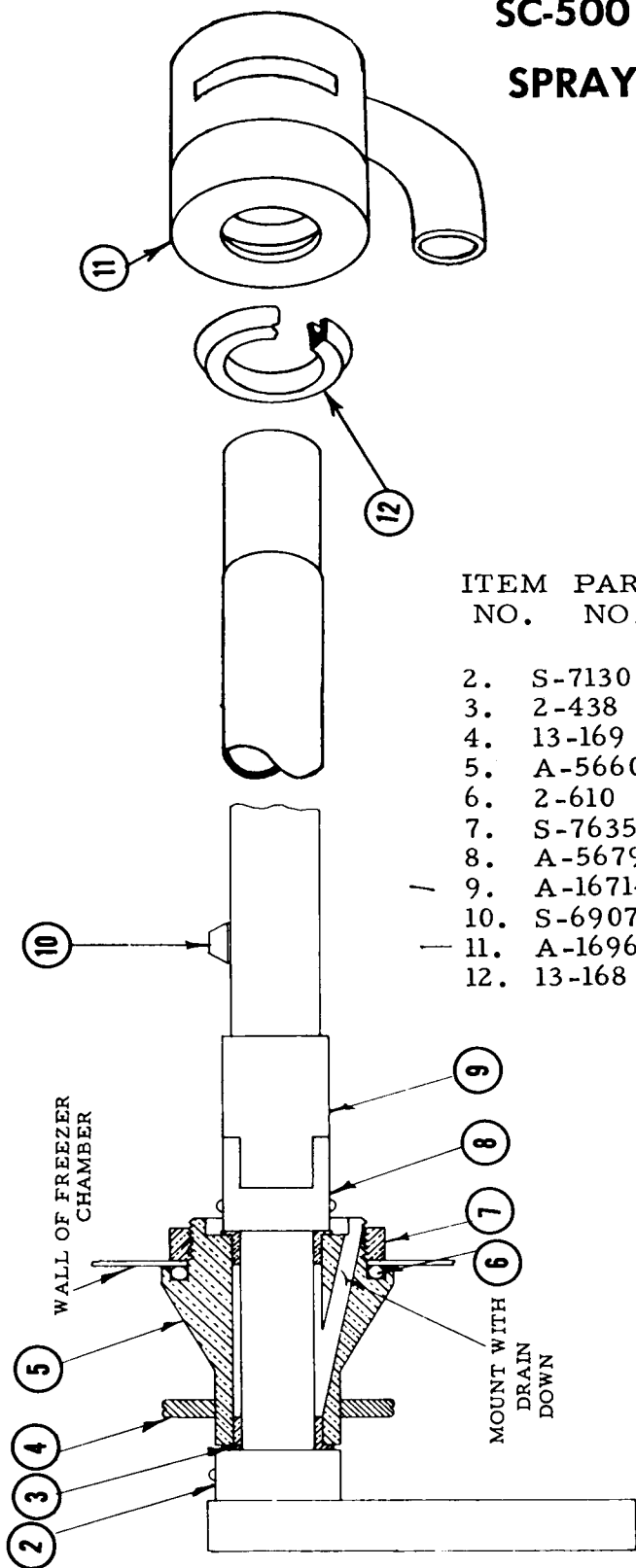

ITEM NO.	PART NO.	NAME
2.	S-7130	Collar
3.	2-438	Flange Bearing
4.	13-169	Grommet
5.	A-5660	Drive Bearing Support
6.	2-610	"O" Ring
7.	S-7635	Nut
8.	A-5679	Drive Journal Ass'y
9.	A-16714	Sprayer Tube
10.	S-6907	Jet
11.	A-16963	End Bearing Ass'y
12.	13-168	"U" Cup

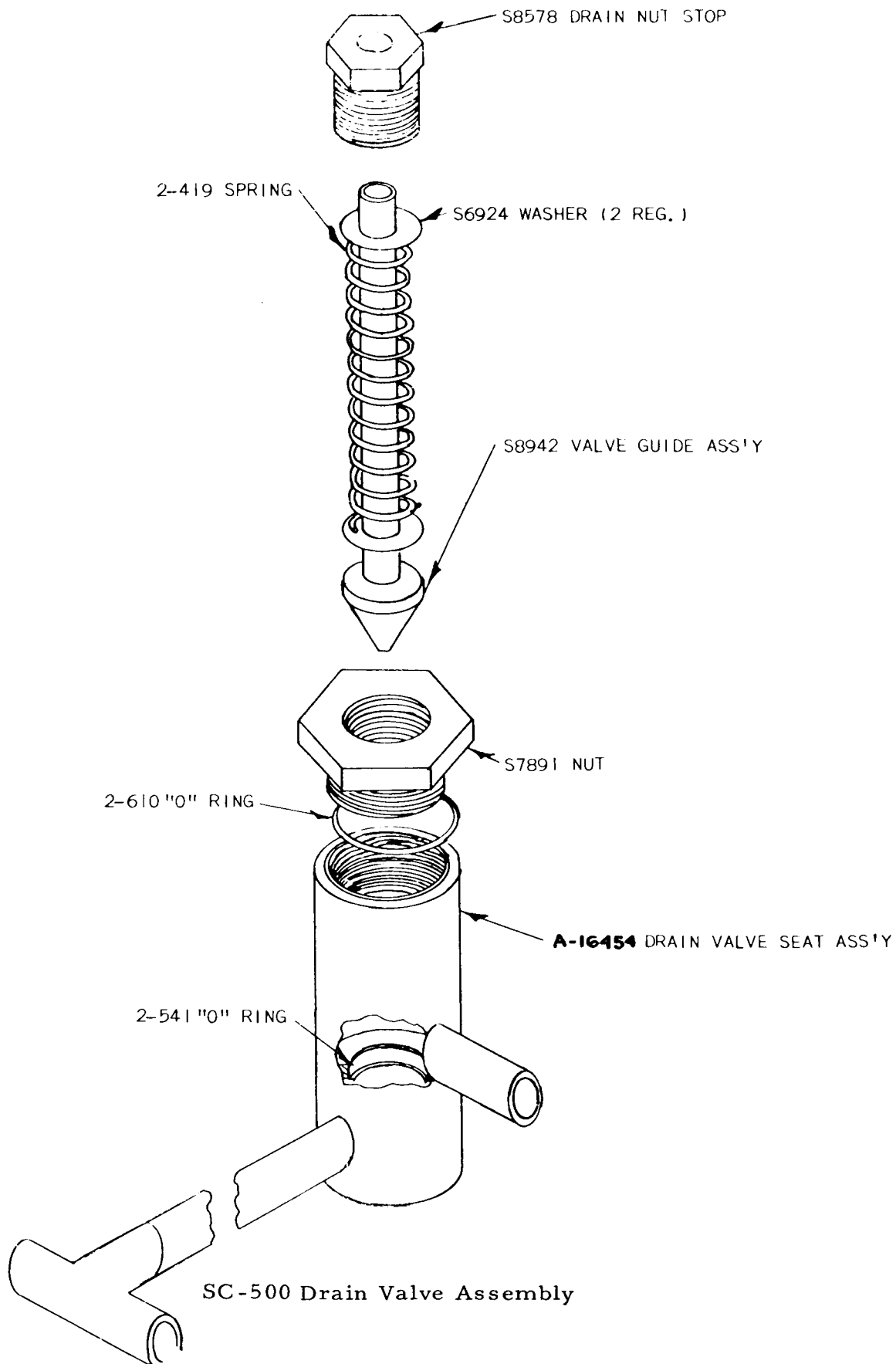

SC-500  
WATER VALVE ASSEMBLY  
LINKAGE AND ADJUSTMENT

INSTRUCTIONS -- WATER VALVE ADJUSTMENT

Adjust solenoid at Point 1 up or down to the point where linkage at Point 2 is free and valve is closed in hot water tank with solenoid open wide.

Adjust valve at Point 3 to 1/4 inch distance from end of valve guide (S-9849) to valve seat (solenoid wide open).

Adjust valve at Point 4 to 0 inch distance from end of valve guide (S-8949) to valve seat (solenoid wide open).

Linkage at Point 5 adjusted to be free.

With solenoid closed, valve in hot water tank should be open about 3/8 inch or more. Valve at Points 3 and 4 should be closed. Spring at Point 3 should be stretched about 1/4 inch. Valve at Point 5 should be open about 3/8 inch.

Trouble -- Hot water tank valve not opening wide enough  
Solenoid should be adjusted lower so to obtain full travel of solenoid.

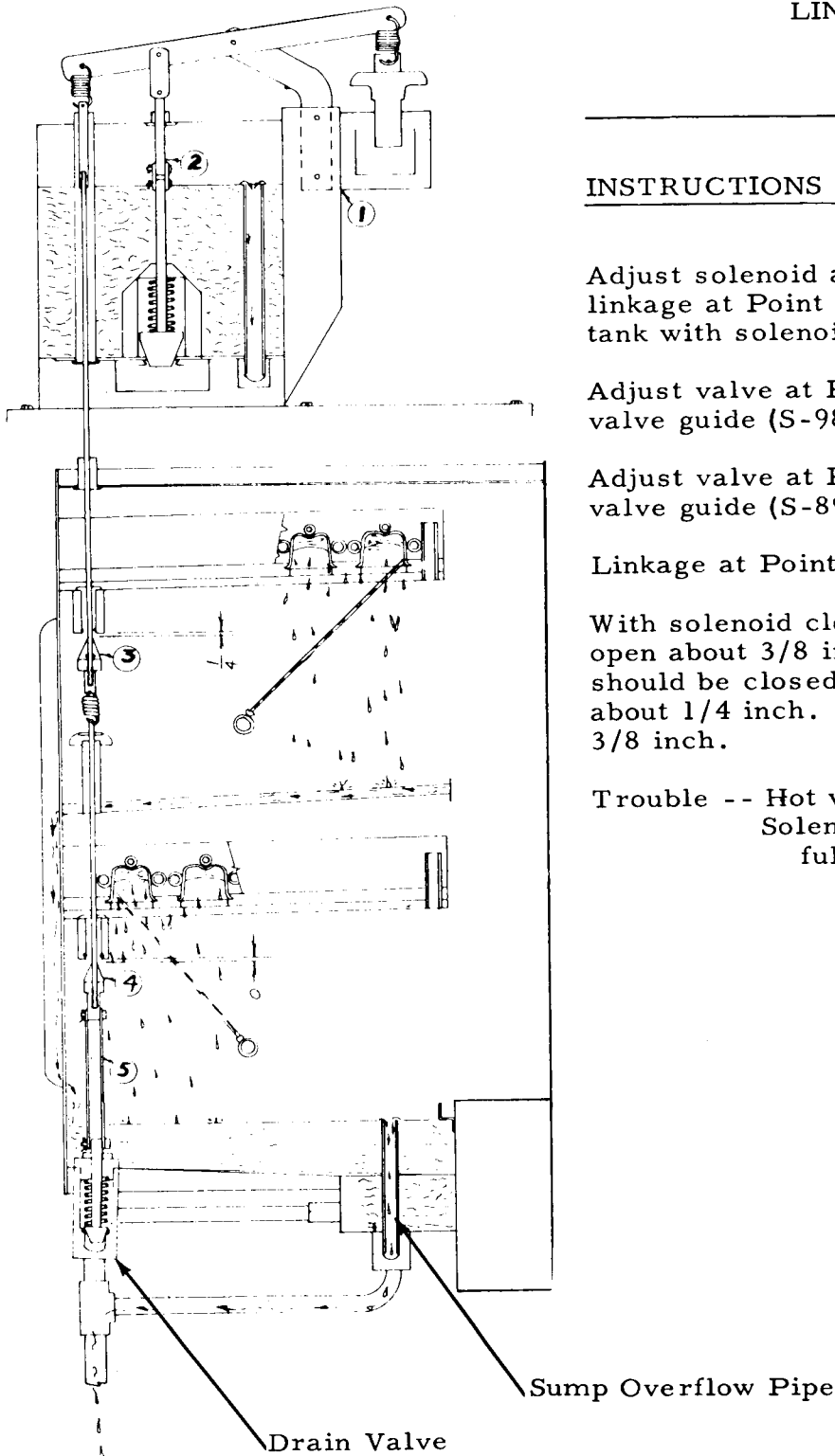

## SERVICE

Scotsman models SC-500 provide the user with the Scotsman Super Cube. By comparison with the Scotsman model MM-510 cuber, whose cabinet it resembles. Models SC-500 produce 160 cubes versus 416 miniature sized cubes in the MM-510 cuber series. For practical purposes we can say the miniature cube is 1/4 the size of regular Scotsman cubes.

Other features of interest are as follows:

1. Air cooled models utilize a fan control on one of the two fan motors to maintain head pressure in low ambient location.
2. Hot water for defrost heated electrically..
3. Plastic curtains secured with thumb screws.
4. Cube chutes fabricated from stainless steel sheets rather than former plated rod types.
5. Automatic defrost and freezing cycles actuated by thermostatic temperature control.
6. Spray bar motor oscillates at 20 RPM.
7. Defrost setting on finishing clock is 3 1/2 minutes.
8. New style finishing clock has enclosed micro switch and offset adjustable cams to carry and direct electrical current thru defrost cycle.
9. All evaporator surfaces are tin dipped.

## SERVICE

### REMOVING AND REPLACING COMPONENT PARTS

#### Capillary Tubes

These controls are an integral part of the suction line, being soldered to it along most of its entirety.

#### To Replace Compressor Valve Plate

1. Install compound gauge in suction service valve port and close suction service valve by turning valve stem all the way in (Front seated)
2. Operate motor compressor until gauge reading reaches zero. Turn off unit.
3. Front seat discharge service valve.
4. Loosen all head bolts and tap head lightly with rubber-faced or plastic hammer to break loose.
5. Remove head, defective valve plate and any gasket material that may have stuck to head or compressor body.
6. Install new valve plate with all new gaskets as provided, tightening each head bolt a little at a time until all are snug.
7. Remove port gauge plug from discharge valve and crack open suction side letting gas purge off trapped air from head. Install hi side gauge in this port, back up both service valve stems and check around valve plate for refrigerant leaks.
8. Start unit, noting head and back pressures. If normal, let run until compressor gets warm. Tighten all head bolts once more, and again check for leaks.

#### To Replace the Compressor

1. Front seat both suction service valve and discharge service valve on the compressor.
2. Disconnect the wiring from the compressor.
3. Remove the bolts holding the service valve to the motor compressor body.
4. Remove the compressor hold-down nuts and lift the compressor out of the unit.
5. Reverse steps 1 through 4 in replacing the compressor.
6. Check the compressor for oil before connecting the oil lines. Should be 2 inches down from the top of the oil plug hole or 1/2 of sight glass.
7. Remove the gauge port plug from the discharge service valve. Crack the suction service valve slightly, allowing some gas to escape out the gauge port of the discharge valve. When you have thoroughly purged the compressor, replace the plug and open all valves. It may be necessary to charge the unit because of some of the gas was lost when the defective compressor was removed. Check and charge if necessary.

## SERVICE

---

### REMOVING AND REPLACING COMPONENT PARTS

#### To Remove Sump Pump

1. Put line switch in "Off" position.
2. Disconnect motor leads from terminals marked sump pump in control box.
3. Loosen cord connector and pull motor leads free.
4. Remove splash cover from sump and lift out pump.
5. Disconnect hoses.
6. To replace, reverse procedure.

#### To Remove Jet Tubes

1. Remove curtains from cube discharge openings.
2. Remove cube slides.
3. Push jet tube up at right end of tube, and bring forward far enough to acquire space to pull left end of tube out of drive mechanism.
4. Now remove stationary elbow coupling from right end of jet tube. Jet tube is now free, can be cleaned from right end opening.
5. To replace, reverse procedure. (Be sure to replace bearing on end of jet tube.) Check O-Ring in right side elbow.

#### To Adjust Linkage on Jet Tubes

1. Remove left access panel.
2. Loosen lock nuts on turn buckles. (Note. One lock nut has left hand thread, the other right.)
3. Adjust turn buckle for desired linkage. (Note. Check at cube discharge opening with flashlight to be sure jet sprays are hitting front and back cups.)
4. Caution. Be sure to tighten lock nuts after adjustment has been made.

#### To Remove Jet Tube Drive Motor

1. Disconnect motor leads on terminals marked drive motor in control box.
2. Loosen connector and remove leads from control box.
3. Loosen Allen head set screw in drive arm.
4. Remove drive arm.
5. Remove motor hold-down bolts. (Note. For easy removal of hold-down bolts, remove access panel.)

#### To Remove Large End Panels

1. Remove concealed screws under door gasket.
2. Remove screws from top and back panels.
3. Pull panels loose from rear of machine.
4. Pull forward and remove. (Note. All insulation used in this machine is in sections in a solid form and can be removed readily to repair water leaks, or any other trouble that might develop.)



## FUNCTIONAL PARTS & MAINTENANCE

- PART NAME: Jet Tube Assembly.
- PART NUMBER: A-16714 2 per unit
- PART FUNCTION: This tube acts as the water distributor for the ice cube cups. Each tube has 26 jets over its length with each jet feeding one row of cups from front to back. Supply water is forced into the jet tubes by the sump pump and is directed upward in a continuous stream. Drive motor through drive linkage forces these tubes back and forth over a 20° arc which covers all cube cups.
- PART SETTINGS: Factory set. Occasionally the spray tube travel will be either too far forward or back missing the first or last row of cups as the case may be. This can be corrected by adjusting the nuts provided on the drive linkage.
- PART REPAIRABLE: Yes, jets replaceable.
- PART MAINTENANCE: Check inlet supply elbow to make sure O-ring there is not worn letting water leak at this point.
- All jets should be cleaned also. By running Scotsman Ice Machine Cleaner through unit this step will eliminate hand cleaning. Partially plugged jets will produce cloudy or partial cubes. Wholly plugged jet will not produce a cube in cube cups it normally covers.
- PART NAME: Sump Pump.
- PART NUMBER: 12-418A-1
- PART FUNCTION: Recirculating Pump used to pump supply water in sump tank to jet tubes during freezing cycle.
- PART SETTINGS: Factory set.
- PART REPAIRABLE: Yes. Motors rewound, impeller blades replaced. Motors only are also available for this pump, Part No. 12-1351-22.
- PARTS MAINTENANCE: Cleaning a stuck motor with carbon tetrachloride or equivalent will re-activate the majority of the motors

## FUNCTIONAL PARTS & MAINTENANCE

PART NAME: Agitator Drive Motor 20 RPM Merkle Korff

PART NUMBER: 12-446

PART FUNCTION: This motor is used to drive the linkage mechanism which in turn drives the oscillating jet spray tubes. This provides a constant spray movement to all the inverted cube molds and by so doing also aerates the water producing clear, solid Scotsman cubes.

PART SETTINGS: No settings on motor, however, there are adjustable mounts which allow for moving motor slightly to position correctly.

PART REPAIRABLE: Yes, to some extent. Bearings, windings, etc., may be replaced in electric motor shops. Normally replace.

PART MAINTENANCE: Proper care in oiling with SAE 20 every six months or less as use indicates. There are two oil cups on the motor and a gear case hex head screw which has to be removed to change or add oil in gear case proper.

Drive linkage should be inspected to insure free movement and no binding or drag on drive motor.

PART NAME: Spray Tube Drive Linkage

PART NUMBER: A-17230

PART FUNCTION: To connect and transmit mechanically, drive motor power to jet tubes assembly. Consists of 3 arms fastened one each to the two jet tubes and one drive motor. Arms are connected by a two piece rod which has an adjustment nut in the middle to correct spray tube travel.

PART SETTINGS: Factory set. Linkage should be adjusted so that there is no drag on drive motor and also to insure spray tube travel across all cube cups.

PART REPAIRABLE: Yes. All components replaceable.

PART MAINTENANCE: Check linkage for binding or worn spots. Tighten set screws holding arms to spray tubes and drive motor.

FUNCTIONAL PARTS & MAINTENANCE

- PART NAME: Hot water tank complete.
- PART NUMBER: A-17426-1
- PART FUNCTION: Tank serves dual purpose, stores correct amount of incoming supply water for next freezing cycle and also heats it electrically for use in defrosting preceding batch of cubes. Water inlet valve and float ball maintain correct water level. Thermostat and heating element maintain constant hot water temperature. 135°F.
- PART SETTINGS: Factory set. Water float level has adjustment arm. Water level should be maintained 1/4" below overflow pipe. Thermostat governing temperature, of heating element has a scale and pointer which is factory set 135°F.
- PART REPAIRABLE: Yes. All components of tank are replaceable. Water inlet valve. A-6771, heating element part No. 12-532 and thermostat Part No. 12-246 are easily changed.
- PART MAINTENANCE: Periodic cleaning with Scotsman Ice Machine Cleaner will dissolve accumulated scale on inlet valve seat, heating element and side walls of hot water tank. This in turn prevents excess loss due to leaky inlet valve and more efficient operation of heating element.
- PART NAME: Water Valve Assembly
- PART NUMBER: A-8332
- PART USAGE: Used on all models.
- PART FUNCTION: This portion of water valve extends thru unit from top to bottom and is actuated by the 12-1396-1 solenoid. During defrost periods it positions one seat to each freezer assembly and shunts hot water to those trays while also opening bottom drain valve. During freezing cycle seats to freezers drop down as does bottom drain seat, closing off drain water. This assembly made in sections which can be dismantled from inside.
- PART SETTINGS: Entire valve can be adjusted either individually on each seat and drain seat or as a whole by taking up top rod adjustment to solenoid.
- PART REPAIRABLE: Yes. All components in valve linkage available from factory stock.
- PART MAINTENANCE: Care should be exercised in seeing that seats to platens or freezer trays, close fully during defrost and that hot water drain in tank opens 3/4" letting defrost water leave tank. Linkage when in defrost position will allow the 12-1396-1 actuating solenoid to fully close and when in freezing cycle to fully open. Seats, rods and springs in valve linkage should be checked for adjustment and wear every six months.



## FUNCTIONAL PARTS & MAINTENANCE

- PART NAME: Reverse Acting Temperature Control
- PART NUMBER: 11-345-1
- PART FUNCTION: Reverse acting temperature control, closes on temperature decrease, opens on temperature rise. Control determines length of freezing cycle and by the same token, the cube size. A lower setting on control will produce larger cubes, a higher setting, smaller cubes. This control actuates time clock motor, Part No. 12-645-1, which then takes over balance of freezing cycle ( 8 1/2 minutes) and also defrost period 3 1/2 minutes.
- PART SETTINGS: Adjustable by screw driver slot.
- PART REPAIRABLE: No. Replace when inoperative.
- PART MAINTENANCE: Check electrical connections. Blow points free of dust, dirt, lint, etc.
- PART NAME: Contactor
- PART NUMBER: 12-820-1
- PART FUNCTION: Across the line contactor used to provide protection for hi voltage compressor only. Contactor is wired so any of the controls in pilot circuit such as bin thermostat will cause contactor holding coil to drop contact points when actuated. There are no overloads or resets on this control.
- PART SETTINGS: Factory set, no adjustments necessary.
- PART REPAIRABLE: No. Replace
- PART MAINTENANCE: Check control for loose electrical connections and blow free of any dust, dirt, etc.

## FUNCTIONAL PARTS & MAINTENANCE

- PART NAME:** Temperature Control Storage Bin. White Rodgers Type 16A64-9
- PART NUMBER:** 11-99-1
- PART FUNCTION:** To automatically cut machine off when ice level in storage bin reaches thermostat bulb. Automatically starts machine when ice level in bin falls below bulb location.
- PART SETTINGS:** Most of these controls have differential being 4° F. Settings are 35° cut out and 39° cut in.
- PART REPAIRABLE:** No. Replace when inoperative. If out of warranty it can be sent in through your local refrigeration supply dealer and repaired or replaced for a small percentage of original cost.
- PART MAINTENANCE:** Remove cover, check points for corrosion or arcing every six months. Blow control free of bugs, dirt, etc. Check capillary for cracks or worn spots due to vibration.
- Hold small handful of ice on thermostat bulb to check operation of control. Tighten electrical connections.
- PART NAME:** Timer. Automatic Electric.
- PART NUMBER:** 12-645-1
- PART USAGE:** Heart of the cyclematic control system is the cube size temperature control Part No. 11-345-1 and the time clock it actuates. All electrical components are connected to the time clock terminal board and are shunted by means of a micro-switch to either the freezing cycle or harvest cycle. Micro-switch is in turn actuated by two metal cans that are directly connected to the electric timer clock motor. Timer has a 12 minute cycle, 8 1/2 minutes on freezing cycle after being cut on by low temperature control and 3 1/2 minutes on defrost cycle. Time clock face has numerals to 7 on half the face. Each numeral represents a minute period. Face also has a lever beneath it which can be moved to lengthen or shorten defrost period.
- PART SETTINGS:** Normal setting for defrost is on No. 3 1/2 which is 3 1/2 minutes.
- PART REPAIRABLE:** Yes. Micro-switch, Part No. 12-645-1 are replaceable as well as timer clock motor only Part No. 12-367.
- PART MAINTENANCE:** Check all electrical connections, blow contact points free of dust, dirt, etc.

## MAINTENANCE INSTRUCTIONS FOR SCOTSMAN SUPER CUBERS

THE FOLLOWING MAINTENANCE MUST BE ACCOMPLISHED TWO (2) TIMES PER YEAR ON ALL SCOTSMAN SUPER CUBERS.

1. Clean air-cooled condenser. This is to be done frequently with the machine shut off. Air cooled models.
2. Clean hot water tank and evaporator, sump tank and screen, using Scotsman Ice Machine Cleaner or equivalent.
3. Remove jet tube and manually clean jets.
4. Check curtain assemblies. Replace any broken sections.
5. Tighten all electrical connections.
6. Tighten all bolts.
7. Check water supply. Clean and flush flow control. Clean water strainer.
8. Oil jet tubes drive motor three (3) places. Use SAE 20 oil--2 oil cups, 1 crankcase screw covered opening.
9. Oil sump pump motor. Necessary to remove pump on some models. Use SAE 20 oil. Note: Some pumps are ball bearing style, they have no oilers hence need no oiling.
10. Oil condenser fan motor. Punch sealed cap or remove screws where possible.
11. Check for refrigeration leaks with halide torch.
12. Check for water leaks. Tighten drain line connections.
13. Check size and condition of cubes. Adjust as required. See Service Analysis Section.
14. Check bin thermostat setting. Factory set at 35° out, 39° in.

## PROCEDURES FOR USE OF SCOTSMAN ICE MACHINE CLEANER IN SCOTSMAN ICE MACHINE.

1. Remove front access doors.
2. Locate control box with time clock knob protruding thru cover.
3. Put unit through a harvest cycle manually. This may be done by turning time clock knob clockwise until a loud snap is heard.
4. Let unit finish cube harvest cycle and start into freezing cycle. This will be approximately 5 minutes after the loud snap in Step #3 is heard. At this time turn off the compressor switch.
5. Locate the hot water tank which is directly behind the top access door. Remove the hot water tank cover by pulling up around the edge until it snaps off. Pour 16 ounces, of "Scotsman Ice Machine Cleaner" into the hot water tank.

6. Locate the sump reservoirs which are directly behind the ice discharge chutes. The discharge chutes are covered by a series of white plastic curtains which are free to swing out into the storage bin. Pour 8 ounces, of "Scotsman Ice Machine Cleaner" into each sump reservoir at both the upper and lower levels.
7. Let unit operate normally for 10-15 minutes into the freezing cycle. No ice will be made because the motor compressor is not in operation.
8. At the end of this time put the unit through 2 or 3 harvest cycles manually to allow fresh make up water to clean out remaining solution. Each time waiting approximately 5 minutes after the loud snap until the next harvest cycle is done manually.
9. Turn the compressor switch back on.
10. Check each new batch of new cubes until they are clean and until acid taste has been removed from cubes.
11. Put hot water in storage bin to melt the cubes and thereby clean the drains with the same solution that has just cleaned the unit.
12. Use a damp cloth to wipe off curtains and inside of storage bin.
13. Replace all access doors.
14. Unit is now ready for continued automatic operation.



DESCRIPTION	DESCRIPTION
<b>CASE PARTS</b>	<b>ELECTRICAL</b>
Scotsman Emblem 15-474	Temperature Control (W-R) 11-99-1
Left Side Door A-17211	Timer 12-645-1
Bulb Cover A-15759	Control, Cube Size 11-345-1
Bulb Gasket 13-590	Relay (Bin Thermostat) 12-419
Adapter Plug (Freezer Assembly) S-7434	Drive Motor 12-446
Right Side Panel, W.C. A-9323	Sump Pump 12-418A-1
Right Side Panel, A.C. A-8490	Contactor 12-820-1
Left Side Panel A-17210	Terminal Block 12-813
Back Panel, W.C. A-9321	Toggle Switch (On/Off) 2/unit 12-426
Back Panel, A.C. A-8495	
Drive Bearing Support A-5660	<b>COND. UNIT</b>
Top Panel A-5694	
Center Cube Deflector A-16716	Dryer 2-677
Upper Cube Chute, Left A-17272	Relay, W.C. 18-1903-18
Upper Cube Chute, Right A-16270	Dual Pressure Control 11-286
Lower Cube Chute, Left A-16718	Motor Compressor-- 230/60/1, W.C. 18-546
Lower Cube Chute, Right A-16720	Valve Plate and Gaskets 18-326
Shroud Top, A.C. A-8521	Water Cooled Condenser 18-599
Upper Curtain Assembly A-17243	Water Regulating Valve 11-198
Lower Curtain Assembly, Right A-16777	Motor Compressor-- 208/60/1, W.C. 18-550
Lower Curtain Assembly, Left A-16778	Starting Capacitor, W.C. 18-1901-15
Door Nut, 6 reqd. 3-1029	Running Capacitor, W.C. 18-1902-17
Door Screws, 6 reqd. 3-789	Overload Klixon 18-533
Upper Door Assembly A-16875	Terminal Assembly 18-270
Front Door Liner Assembly 2-1536	Service Valve Gasket 18-561
Lower Front Door Assembly A-17352	Plain Condenser Gasket 18-548
Upper Face Plate Assembly A-18311	Manifold Condenser Gasket 18-549
Lower Face Plate Assembly A-16662	(2 per unit) Fan Motor 18-559
Bulb Holder Buttons A-16108	(2 per unit) Fan Blades 18-625
Cube Tray Assembly, 2 reqd. A-17285	(2 per unit) Fan Motor Bracket 18-636
Accumulator Cover S-9805	Condenser, Air Cooled 18-624
Door Gasket A-17571	Vibration Eliminator 16-317
	Motor Compressor, 230/60/1, A.C. 18-621
	Motor Compressor, 208/60/1, A.C. 18-631

For stainless steel case  
parts add -S to Part No.

WATER VALVE

DESCRIPTION		DESCRIPTION	
Upper Valve Rod	S-8943	Water Valve Assembly, Complete	A-8332
Rubber Valve Seat "O" Ring	2-541	Valve Seat Washer	S-6924
Rubber Valve Seat "O" Ring	2-530	Valve Lever	A-8763
Middle Valve Rod	A-8199	Valve Plunger	S-8839
Valve Nut	S-8946	Valve Link	A-8188
Middle Valve Spring	2-549	Drain Valve Seat Assembly	A-8182
Lower Valve Rod	S-8951	Drain Valve Guide	S-8942
Lower Valve Link	S-8953	Valve Guide Assembly	S-8949
Spring (Drain Valve Seat Assembly)	2-419	Short Pin (Water Valve) S.S.	S-7974
<hr/>		Roll Pin	3-774
WATER CIRCUIT		Water Deflector Cup	A-18355
Spray Tube Assembly	A-16714	Spring (Solenoid & Water Valve)	2-420
Inlet Pipe Assembly (Upper)	A-5858	<hr/>	
Inlet Pipe Assembly (Lower)	A-5859	HOT WATER TANK	
End Bearing Assembly	A-16963	Long Pin (Solenoid)	S-2186
Overflow Pipe (Sump)	A-17521	Water Inlet Valve	A-6771
Strainer	16-207	Valve Seat	S-6947
"U" Cup	13-168	Nut (Inlet Valve)	S-7044
<hr/>		Hot Water Tank Assembly	A-17426-1
DRIVE MOTOR & LINKAGE		Standpipe Overflow	A-8610
Single Driven Arm Assembly	A-17232	Hot Water Tank Cover	A-13385
Double Driven Arm Assembly	A-17233	Compression Spring (Hot Water Tank)	2-419
Linkage Coupling	S-7936	Float Assembly	A-12068
Linkage Rod, Lower	A-17234	Drain Screen, Water Tank	A-16378
Left Linkage Rod	S-7940	Valve Spring	2-420
Linkage Rods, Right	S-7938	Wing Nut	3-255
Complete Drive Linkage Assembly	A-17230	Right Bracket Support	A-8175
Driver Arm Assembly	S-9666	Left Bracket Support	A-8173
Set Screw	3-431	Hot Water Tank	A-8171
Drive Motor	12-446	Heating Element	12-532R
Left Linkage Nut	S-7937	O Ring	2-530
Right Lock Nut (Two reqd.)	3-357	Solenoid	12-1396-1
Driving Journal Assembly	A-5679	Flow Control	A-13346-4
Drive Motor Grommets	13-100	Thermostat	12-246
Bearing, Oil Lite	A-7033	Thermo Disc Cover	A-6480
		Plastic Water Deflector	2-1320
		Solenoid Mount	A-18275
		Elastic Stop Nut, 4 reqd.	3-1284
		Grommet, 4 reqd.	13-625
		Washers, 4 reqd.	13-298
		Screws	3-499