

# TABLE OF CONTENTS

Table of Contents .....	1
List of Illustrations .....	1
Specifications .....	2
<b>GENERAL INFORMATION &amp; INSTALLATION</b>	
Introduction .....	3
Location and Leveling .....	4
Install Transport Tube Assembly .....	5
Electrical Connections .....	6
Water Supply and Drain Connections .....	6
Final Check List .....	7
<b>OPERATING INSTRUCTIONS</b>	
Start-Up .....	8
Icemaker .....	10
Electrical/Refrigeration .....	10
<b>ADJUSTMENT AND REMOVAL AND REPLACEMENT</b>	
Adjustment of the Bin Thermostat Control .....	12
 (Printed in Yellow)	
<b>THE PARTS ILLUSTRATIONS AND PARTS LISTS</b>	
General .....	13
How to Order Parts or Assemblies .....	13
<b>WIRING DIAGRAMS</b> .....	
Adjustment of the Water Regulator Assembly — Water-Cooled Models .....	29
Adjustment of the Water Reservoir Float .....	29
Removal & Replacement of the: Auger, Water Seal, Bearings and Ice Breaker .....	29
Compressor Assembly .....	30
Condenser — Air-Cooled Models .....	30
Condenser — Water-Cooled Models .....	31
Drier .....	31
Drivemotor Assembly .....	31
Elbow & Switch Assembly .....	32
Fan Motor Assembly — Air-Cooled Models .....	32
Freezer Assembly .....	32
Water Regulator Assembly — Water-Cooled Models .....	33
Water Reservoir Assembly .....	33
Safety Pressure Controls .....	34
<b>SERVICE DIAGNOSIS</b>	
Icemaking — Refrigeration System .....	35
<b>MAINTENANCE &amp; CLEANING INSTRUCTIONS</b>	
General .....	38
Icemaker .....	38
CLEANING — Icemaker .....	39

# LIST OF ILLUSTRATIONS

Specifications — Model MH750 .....	2
Component Location .....	3
Installation Examples .....	4
Installation Ice Transport Tube and Bin Thermostat Bracket .....	5
Installation Practice .....	7
Water Schematic .....	9
Refrigeration Cycle .....	9
Adjustment of the Temperature Control .....	12
 (Printed in Yellow)	
How to Use the Illustrated Parts List .....	13
Model MH750 Cabinet .....	15
Major Assemblies .....	17
Air-Cooled Assemblies .....	18
Water-Cooled Assemblies .....	19
Elbow & Switch Assembly .....	20
Freezer Assembly .....	20
Compressor Assembly .....	21
Drivemotor Assembly — MH750 1/4 H.P. ....	22
Control Box Assembly — MH750 Air-Cooled .....	23
Control Box Assembly — MH750 Water-Cooled .....	24
Wiring Diagram — Air-Cooled .....	25
Wiring Diagram — Water-Cooled .....	26
 Removal of the Freezer Assembly .....	
Removal of the Water Reservoir Assembly .....	33

**THIS PAGE  
INTENTIONALLY  
LEFT BLANK**

# MH750 ICE NUGGET MODULAR CUBER

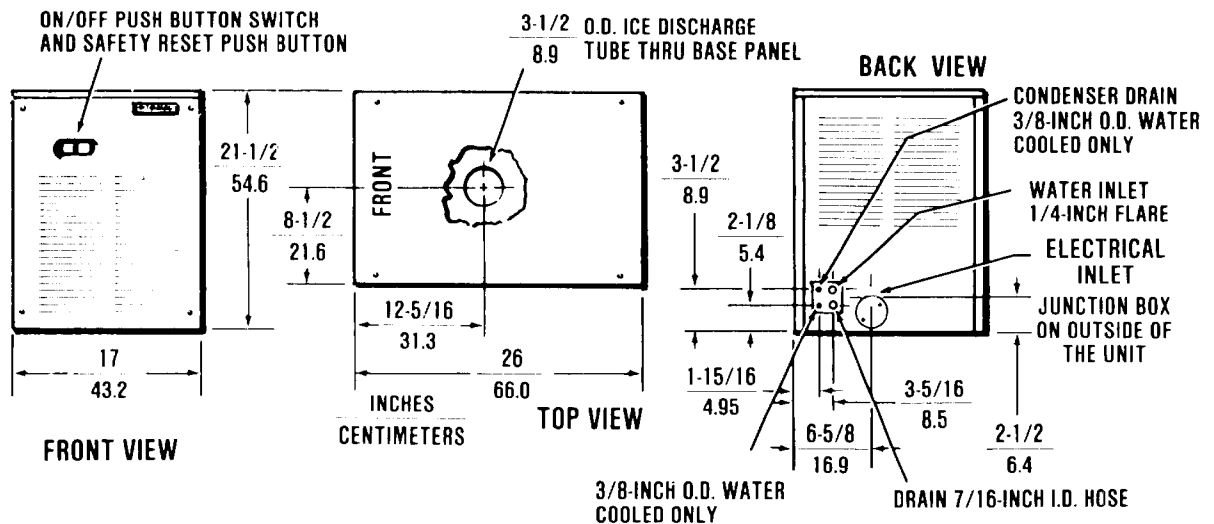

**INSTALLATION NOTE:** Allow 6" minimum additional space at sides, front and back for ventilation and utility connections.

This product qualifies for the following listings:



## SPECIFICATIONS

Model Number	(Height - w/o Legs) Dimensions H" x W" x D"	Cube	Cond. Unit	Finish **	Basic Electrical	Comp. H.P.	Run. Amps.	Max. Oper. Amps.	No. of Wires	Min. Circuit Ampacity †	Max. Fuse Size	Shpg. Wt. lbs./kg.
MH750AE-1A	21 1/2 x 17 x 26	Nuggets	Air	EC	115/60/1	3/4	15.7	15.7	2	19.0	20	195/88
MH750WE-1A	21 1/2 x 17 x 26	Nuggets	Water	EC	115/60/1	3/4	15.7	15.7	2	17.0	20	187/85

\*\*EC Charcoal Brown high-gloss, baked enamel finish on leathergrain embossed steel.

†Use this value to determine minimum wire size as per National Electric Code Standards.

## IMPORTANT OPERATING REQUIREMENTS

	MINIMUM	MAXIMUM
Air Temperatures	50°F (10.0°C)	100°F (37.7°C)
Water Temperatures	40°F (4.4°C)	100°F (37.7°C)
Water Pressures	20 lbs. gauge	120 lbs. gauge

### Electrical Voltage Variation

Voltage rating specified on nameplate	-10%	+10%
---------------------------------------	------	------

Extended periods of operation exceeding these limitations constitutes misuse under the terms of Scotsman Manufacturer's Limited Warranty, resulting in a loss of warranty coverage.

## OPTIONAL STAINLESS STEEL PANEL KITS

SPKM750A contains top, front and 2 side panels. Not factory installed.

## STORAGE BINS:

The MH750 is ideally dimensioned to fit on the B90 Bin with KBT4H top which has 3 knockouts to conveniently accept one MH750 centered or two MH750s side-by-side.

# GENERAL INFORMATION AND INSTALLATION

## INTRODUCTION

This manual provides the specifications and the step-by-step procedures for the installation, start-up, operation, maintenance and cleaning of the SCOTSMAN Model MH750 Modular Nugget Icemaker.

The Model MH750 Icemaker is a quality designed, engineered and constructed, and thoroughly tested icemaking system, providing the utmost in flexibility to fit the needs of a particular user.

## DESCRIPTION

An attractive compact cabinet of textured metal with a charcoal brown enamel finish. The MH750 icemaking system produces ice nuggets. The hard "Ice Nuggets" are small cylinder shaped pieces with the slow melting advantages of cubes and economy of flakes.

## SEALED REFRIGERATION SYSTEM

To provide quiet, efficient operation of the icemaker, the compressor motor is internally spring-mounted. The compressor motor is covered by a five-year parts warranty.

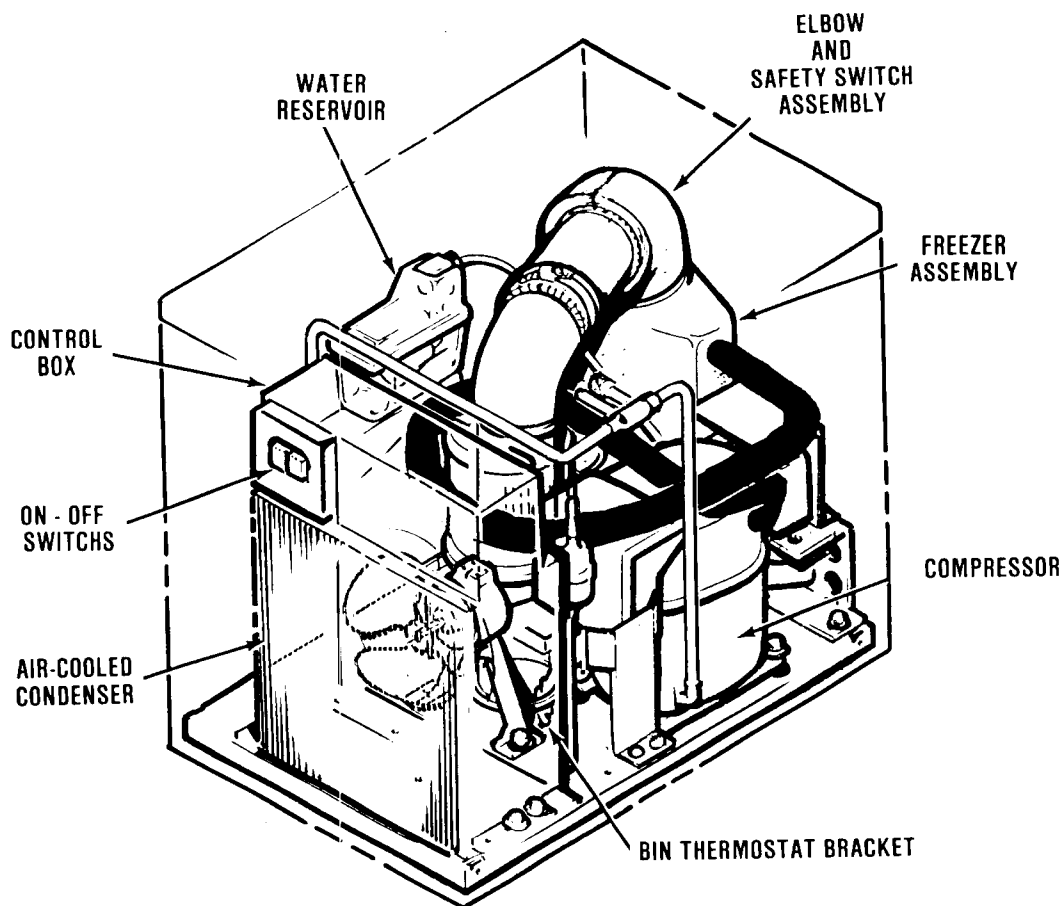

*Component Location*

# MH750 GENERAL INFORMATION & INSTALLATION

## LOCATION AND LEVELING

### ////////// WARNING //////////

This Icemaker is **NOT** designed for outdoor installations where air temperatures are below 50-degrees F., or above 100-degrees F., and water temperature is below 40-degrees F., or above 100-degrees F. Extended periods of operation at temperatures exceeding these limitations will constitute misuse, under the terms of the SCOTSMAN manufacturer's limited warranty, resulting in **LOSS** of warranty coverage.

### ////////// //////////

1. Position the Cabinet in the selected permanent location.

### NOTE

Prior consideration for location site shall include:

Minimum room temperature 50-degrees F.  
Maximum room temperature 100-degrees F.

Water inlet temperatures:

Minimum ..... 40-degrees F.  
Maximum ..... 100-degrees F.

Well ventilated location for air-cooled model, advising user to frequently clean air-cooled condenser, located directly behind the front panel.

**CONVENIENCE:** Placed for practical, efficient use in a back bar or front bar location; or as an individual counter unit, providing hard, nugget ice.

**SERVICE ACCESS:** Adequate space for all service connections, located at the back of the cabinet. A six-inch minimum clearance at rear and side panels, for routing cooling air drawn into and exhausted out of the compartment to maintain proper condensing operation on air-cooled models.

2. Level the selected bin in both the left-to-right and front-to-rear directions. The leveling legs can be adjusted with an open end wrench.

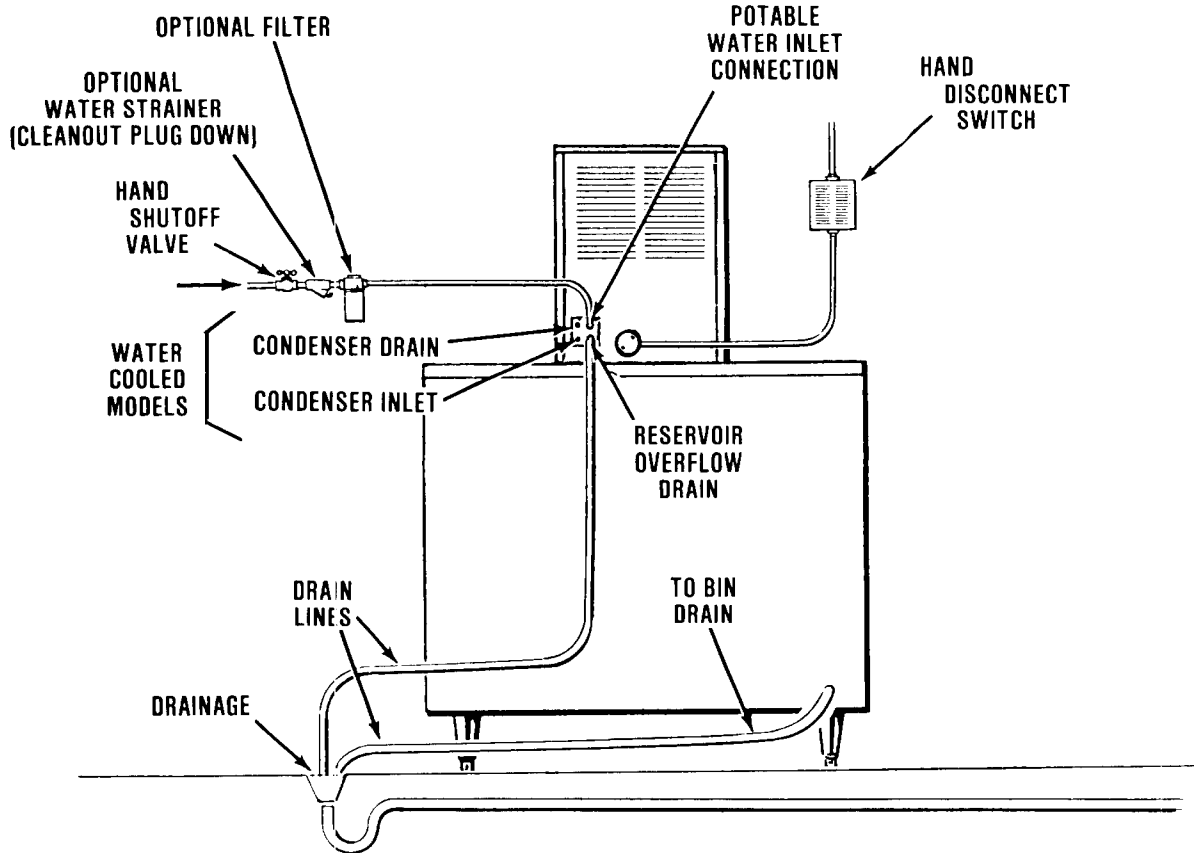

OPEN, TRAPPED OR VENTED DRAINS MUST MAINTAIN 1/4-INCH PER FOOT FALL

# MH750 GENERAL INFORMATION & INSTALLATION

## INSTALL TRANSPORT TUBE ASSEMBLY

The Model MH750 is designed to be installed on top of an ice storage bin and the ice transport tube and bin thermostat bracket extend through the cabinet base and into the ice storage bin.

The ice transport tube, bin thermostat bracket must be assembled and installed before operation.

1. Remove screws and cabinet top panel.
2. Carefully unpack from within cabinet and wipe clean the ice transport tubes.

3. Carefully uncoil the bin thermostat capillary tube to gain enough length.
4. Attach the bin thermostat bracket to the long tube using the two screws provided. Insert the bin thermostat bracket end through the center hole. Attach the vertical tube to the horizontal tube with the screw clamp and "U" channel provided.
5. Check the bin thermostat capillary tube routing to be sure it does not contact other parts.

When properly installed, the ring surrounding the vertical tube at the bin thermostat bracket closes the gap around the icemaker base and the bin thermostat bracket and tube extends into the bin.

//////////////////// **CAUTION** //////////////////////  
**Thermostat capillary tube must not be kinked.**  
**Careless handling will cause damage.**  
////////////////////////////////////

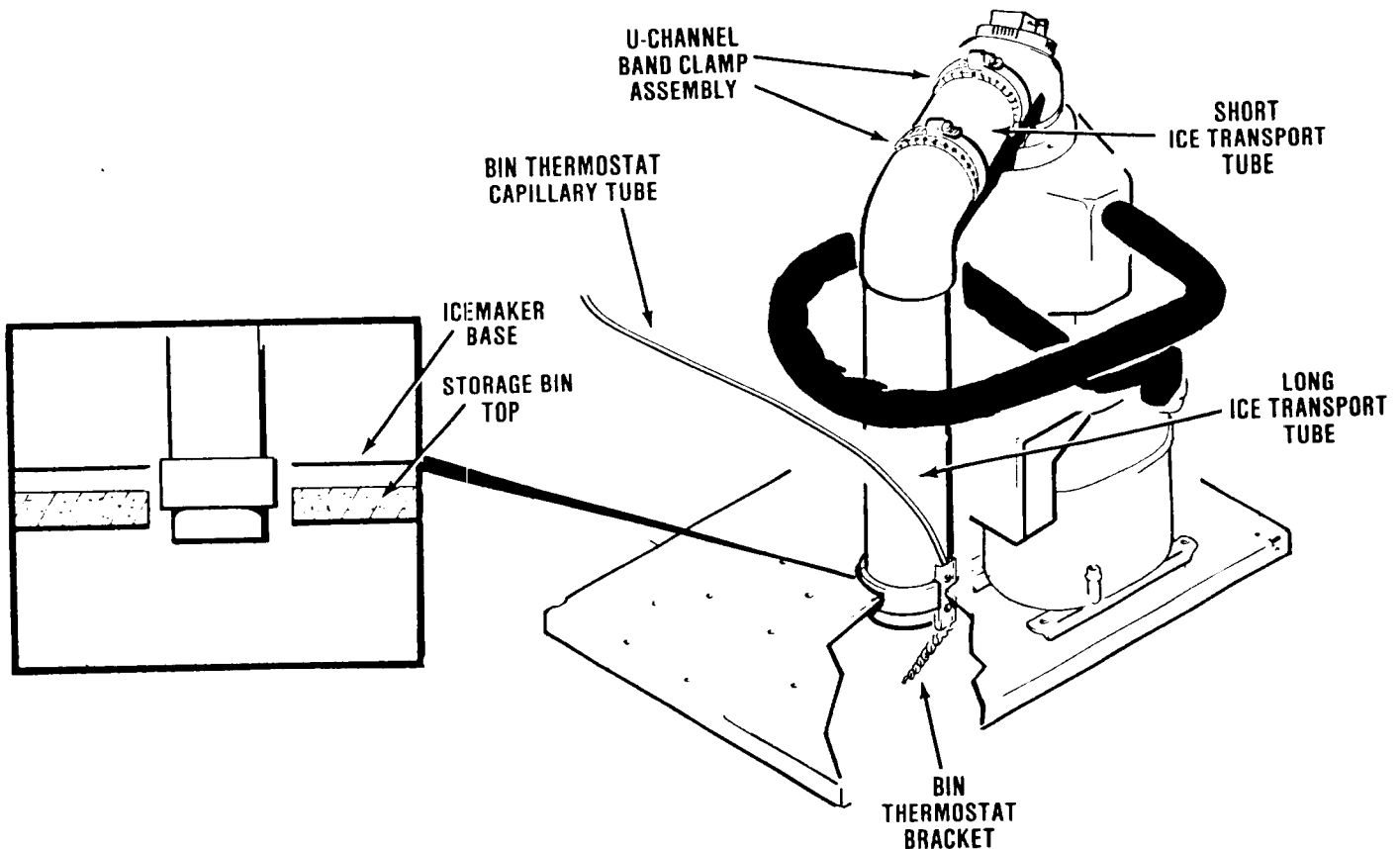

*Installation Ice Transport Tube  
and Bin Thermostat Bracket*

# MH750 GENERAL INFORMATION & INSTALLATION

## ELECTRICAL CONNECTIONS

SEE NAMEPLATE for current requirements to determine wire size to be used for electrical hookup. **The MH750 Icemaker requires a solid earth ground wire.** See wiring diagram.

Be certain the Icemaker is connected to its own electrical circuit and individually fused. The maximum allowable voltage variation should not exceed ten percent of the nameplate rating, even under starting conditions. Low voltages can cause erratic operation and may be responsible for serious damage to the over load switch and motor windings.

**All external wiring should conform to the national, state and local electrical codes. A permit and services of a licensed electrician will be required.**

## WATER SUPPLY AND DRAIN CONNECTIONS

### //////////////////// CAUTION //////////////////////

**This icemaker is equipped with a low water pressure safety device, which in the event of interruptions or low water pressure, the icemaker will automatically stop to prevent damage. It will restart automatically after water pressure is restored.**

////////////////////////////////////

## NOTE

***Water supply must be installed to conform with the local plumbing codes. In some cases a plumbing permit and services of a licensed plumber will be required.***

**POTABLE WATER:** The recommended water supply line is a 1/4-inch O.D. copper tubing with a minimum pressure of 20 PSIG. A 1/4-inch flare fitting is provided at the water inlet. Connect to cold water supply line with standard plumbing fittings, with a shut off valve installed in an accessible place between the water supply and the cabinet.

The icemaker in this cabinet will not operate properly when water supply temperatures are below 40-degrees F. or above 100-degrees F.

**CONDENSER WATER (WATER-COOLED MODELS ONLY):** On water-cooled models a separate connection to the condenser is required. A 3/8-inch O.D. copper tubing is provided for a separate water inlet line to be connected and a separate drain line to be connected.

# MH750 GENERAL INFORMATION & INSTALLATION

## FINAL CHECK LIST

1. Is the cabinet level? (IMPORTANT)
2. Has packaging been removed?
3. Have all electrical and piping connections been made?
4. Has the voltage been tested and checked against the nameplate rating?
5. Is the water supply line shutoff valve installed and electrical wiring properly connected?
6. Have the bin and cabinet been wiped clean?
7. Have the compressor hold-down nuts been checked to be sure the compressor is snug on the mounting pads?
8. Has the owner/user been given the User Manual and instructed on how to operate the icemaker.
9. Has the Manufacturer's Registration Card been properly filled out? Check for correct model and serial numbers from Serial nameplate, then mail the completed card to the SCOTSMAN factory.
10. Check all refrigerant lines and conduit lines, to guard against vibration or rubbing and possible failure.
11. Is there at least six inches clearance behind, in front of and at the sides of the cabinet for proper air circulation?
12. Is the cabinet in a room where ambient temperatures are a minimum of 50-degrees F. all year around?
13. Has water supply pressure been checked to insure a minimum of 20 PSIG?
14. Has the owner been given the name and telephone number of the authorized SCOTSMAN Service Agency serving him?

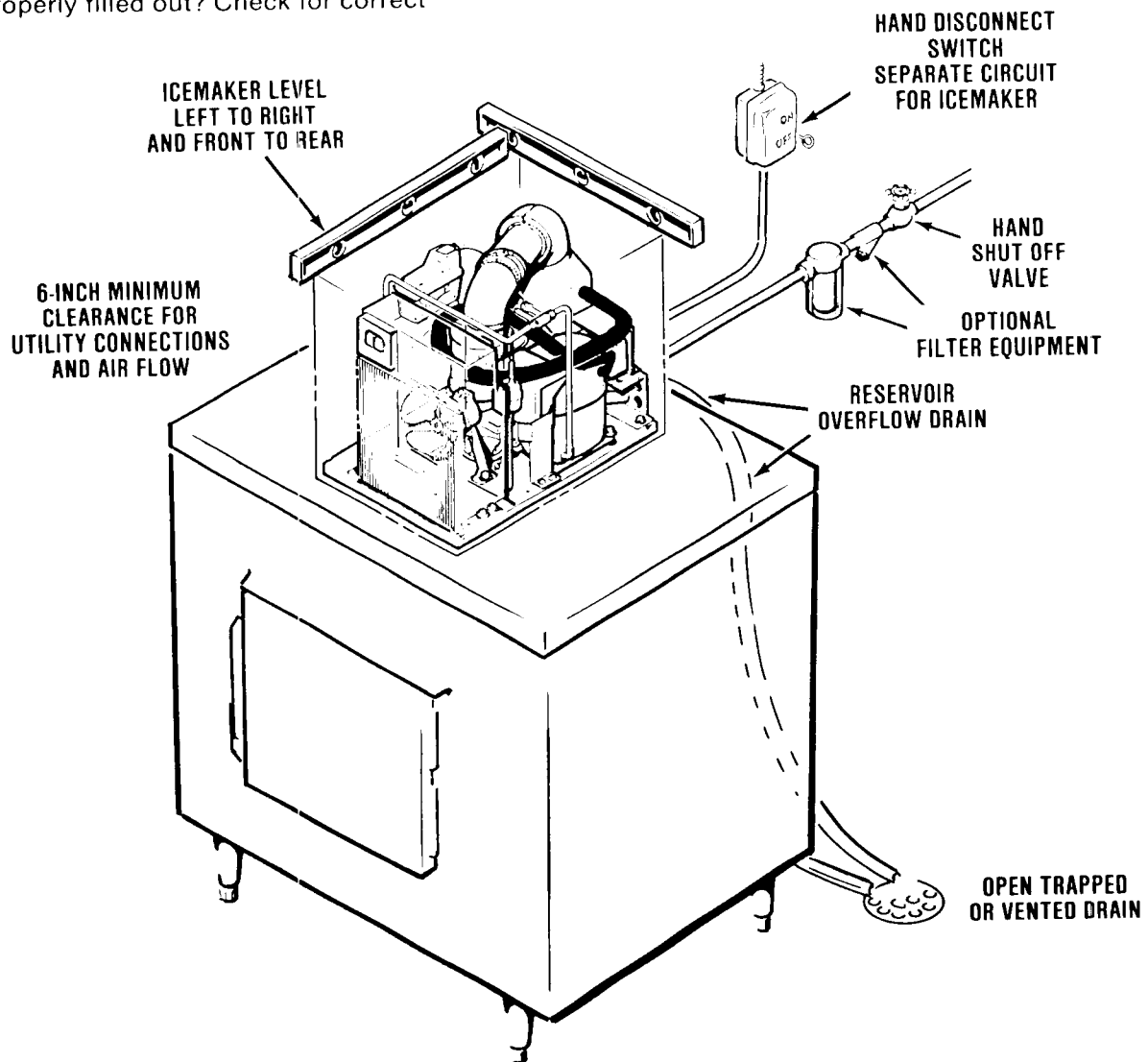

*Installation Practice*



# OPERATING INSTRUCTIONS

## START UP

1. Remove screws and the top, side and front panels.
2. OPEN the water supply line shutoff valve.
3. Observe the water filling operation, see water schematic.
  - a. Water flows into water reservoir.
  - b. Water flows through water feed line to bottom of freezer assembly.
  - c. Float moves up as water rises.
  - d. Float stops water flow, when water level reaches the molded horizontal line, on the body of the water reservoir.
4. Check all internal water connections for leaks.
5. Press the Master ON-OFF pushbutton and the START-RESET to ON position to start the automatic icemaker operation.
7. Let the system operate until ice covers the bottom of the bin. Check for any excess noises beyond normal compressor noise:
  - a. Fan noises, when air-cooled: blades touch other surfaces; blades bent, out-of-balance, or loose on shaft.
  - b. Vibrating type, from touching lines.
  - c. Chattering: Lack of water in freezer.
  - d. Compressor loose at one or more holddown bolts.

//////////////////// **CAUTION** //////////////////////

**This icemaker is equipped with a low water pressure safety device, which in the event of interruptions or low water pressure, the icemaker will automatically stop to prevent damage. It will restart automatically after the water pressure is restored.**

////////////////////

//////////////////// **CAUTION** //////////////////////

**BE ALERT that momentary LOSS OF POWER, such as a brief power outage, will cause the RED light of the START-RESET pushbutton to turn ON. It must be PRESSED, to reset and restart the Icemaker.**

////////////////////

//////////////////// **WARNING** //////////////////////

**Repeated need to PRESS the START-RESET pushbutton, requires checking for:**

1. Faulty bin thermostat control.
2. Need to clear jammed ice tube.
3. Loose wiring connections.

////////////////////

6. Observe that ice begins dropping into the ice storage bin.

8. Place ice on the bin thermostat control bulb, to test shut-off.

*Within minutes after the ice is removed from the sensing bulb, the bulb will warm up and cause the icemaker to restart. This control is factory set and should not be reset until testing is performed. Normal setting is 35-degrees F. CUT-OUT and 45-degrees F. CUT-IN, to prevent short cycling.*

9. Thoroughly explain to the owner/user the significant specifications of the icemaker, the start up and operation, going through the procedures for the operating instructions. Answer all questions about the icemaker, by the owner; and, inform the owner of the name and telephone number of the authorized SCOTSMAN Distributor or Service Agency serving him.

# MH750 OPERATING INSTRUCTIONS

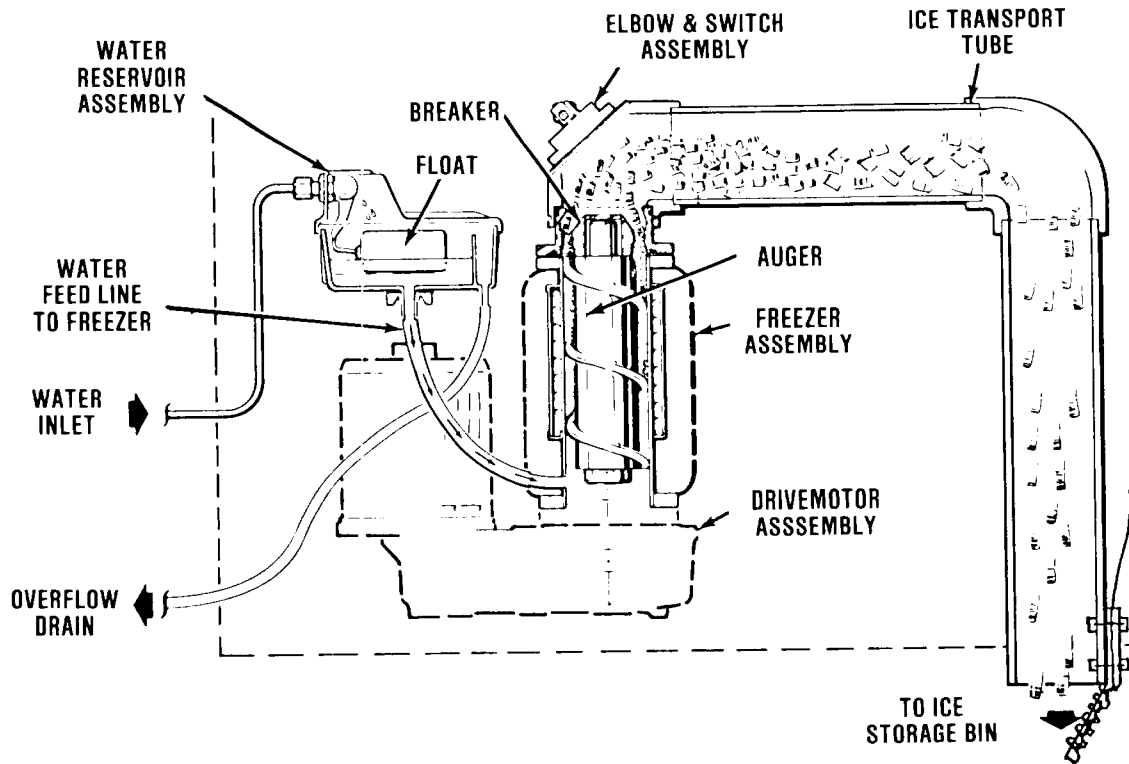

*Water Schematic*

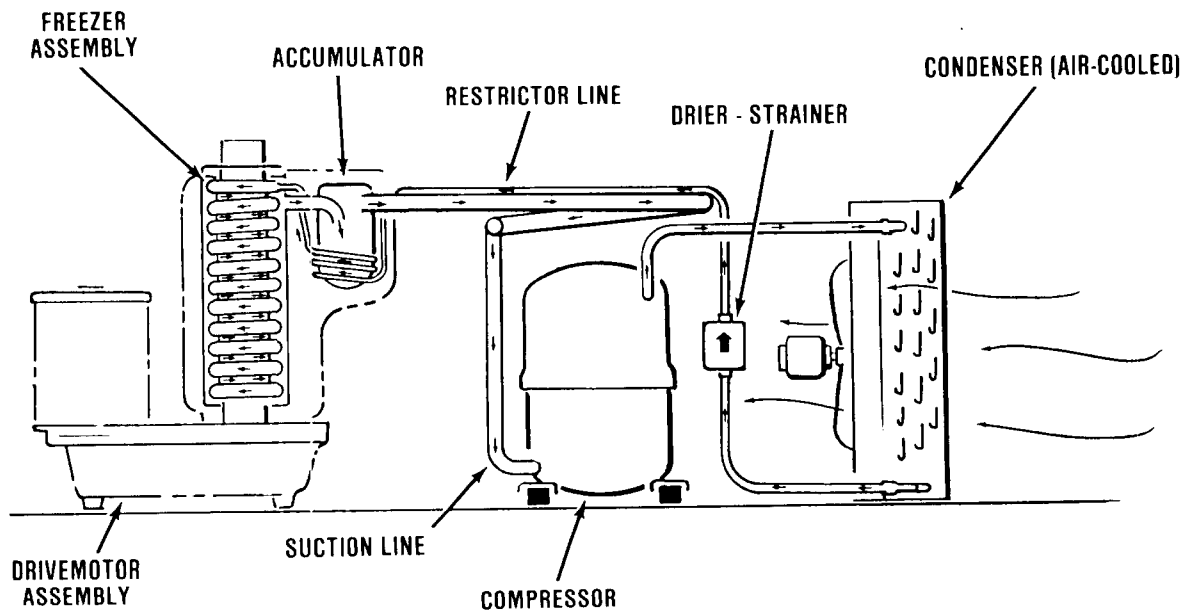

*Refrigeration Cycle*

# MH750 OPERATING INSTRUCTIONS

## ICEMAKER

The potable water supply flows from the building source through the inlet fitting and into the water reservoir. The water reservoir functions to maintain a constant water level inside the freezer assembly. Water from the water reservoir enters at the bottom of the freezer assembly and is changed into ice by low temperatures inside the freezer.

A stainless steel auger within the freezer is powered by a direct-drive gearmotor. The rotating auger carries the ice upward to the end of the auger (See Water Schematic) where excess water is pressed out of the ice as it is extruded and broken into random length chunks. The ice is pushed out through the ice transport tube and into the ice storage bin.

When the ice storage bin fills with ice, to the level of the bin thermostat control capillary bulb, the icemaking process shuts OFF.

As ice is removed from the ice storage bin, the bulb warms up, restarting the automatic icemaking process.

Factory settings for the bin thermostat are 35-degrees F. CUT-OUT and 45-degrees F. CUT-IN.

## ELECTRICAL/REFRIGERATION

The Model MH750 icemakers are designed to operate on standard electrical supply 115 volts, 60 Hertz, single phase. Other voltage requirements are available on special order. Therefore, always CHECK NAMEPLATE for electrical information BEFORE proceeding with electrical wiring connection to the icemaker.

Cold ambient temperatures and interruptions in water supply are conditions that can cause excessively hard ice and overloads within the freezer assembly, which is directly transmitted to the drivemotor; and in turn, will cause speed reduction or ultimate freezeup.

When the drivemotor is slowed to a pre-determined RPM, a sensing switch mounted on top of the motor opens the electrical circuit to the compressor. The compressor stops operating, no more ice is produced, and the drivemotor continues to operate, rotating the auger to clear the overload and gradually build up to full speed.

At a pre-determined higher drivemotor RPM, the speed sensing switch closes the electrical circuit to the compressor, causing the normal icemaking process to resume.

The elbow & switch assembly is mounted on top of the freezer assembly and movement against the rubber diaphragm inside the elbow, actuates the switch. The switch acts as a backup safety switch,

should the bin thermostat control fail and cause ice to jam up in the ice transport tube. When actuated, this safety switch will cause an immediate and complete shutdown of the icemaker. A momentary loss of electrical power to the icemaker will also cause an immediate and complete shutdown of the icemaker. To restart the icemaker, push the START-RESET button.

There are three safety controls in the control box on the water-cooled models and two safety controls in the control box for the air-cooled models. The low pressure control, an automatic reset, nonadjustable control, is used on both models and is set to open at zero to four PSIG to stop the compressor. The auger delay switch, a single-pole double-throw (SPDT) switch, functions as a control device to allow the drivemotor to rotate the auger to clear the freezing chamber while the compressor circuit is OFF.

Refer to the appropriate wiring diagram and trace circuitry and control functions, as described in the following paragraph.

As shown on all SCOTSMAN wiring diagrams, the controls are in the ICE MAKING MODE. Thus, the 1-2 contacts are CLOSED. At STARTUP, the 1-2 contacts are OPEN and the 3-2 contacts are CLOSED. As the icemaker begins to operate, the low side pressure starts to decrease from the stabilized or at-rest pressure. As soon as the pressure is reduced to 20 PSIG, the 3-2 contacts OPEN and the 1-2 contacts CLOSE.

This removes the operating controls, such as the bin thermostat, from the drivemotor circuit. If one of the operating controls OPENS, it will SHUT OFF the compressor circuit. The drivemotor will operate until the low side pressure increases to 32 PSIG. Then, the 1-2 contacts OPEN and SHUTS OFF the drivemotor, usually within one to two minutes, depending upon ambient conditions. This brief period of time allows the auger to transport all the ice out of the freezing chamber. Consequently, when called on to STARTUP again, there is no ice load to start up against. Again, on STARTUP, the 1-2 contacts are OPEN and the 3-2 contacts are CLOSED.

## MH750 OPERATING INSTRUCTIONS

On the water-cooled models only, a manual reset, high head pressure control is factory set to stop the entire icemaker should the head pressure reach 250 PSIG.

On water-cooled models, correct head pressure is 135 PSIG. On air-cooled models, the head pressure is normal about 130 PSIG, however it will vary depending upon ambient air temperature.

Suction pressure should be 10 PSIG with proper refrigerant charge. Suction pressure will vary about two PSIG plus or minus, depending upon ambient temperatures and inlet water supply temperatures to the freezer assembly.

When charging the system with refrigerant, always CHECK NAMEPLATE for specific refrigeration charge for individual icemaker.

# ADJUSTMENT AND REMOVAL AND REPLACEMENT

//////////////////// **WARNING** //////////////////////

**Be sure the electrical power supply to the icemaker is OFF before proceeding with removal procedures.**

////////////////////////////////////

The procedures provided in this section are arranged in alphabetical order, to make specific adjustment and removal and replacement information easy to locate.

Read the instructions thoroughly before performing any adjustment or removal and replacement procedures.

## ADJUSTMENT OF THE BIN THERMOSTAT CONTROL

The control for the bin thermostat is the temperature control, located on the upper part of the retainer wall.

See Adjustment of Temperature Control illustration for location and direction of rotation, clockwise (CW) or counterclockwise (CCW), of the adjusting screws on the temperature control.

To adjust the bin thermostat control:

1. Hold a handful of ice against the capillary bulb in the ice storage bin.

2. Slowly rotate in the appropriate direction, the adjusting screw on the temperature control device until the icemaker shuts OFF.
3. Remove ice from the capillary bulb; then, place warm hand on the capillary bulb to restart the icemaker.
4. Place handful of ice against the capillary bulb and observe that the icemaker should shut OFF.

//////////////////// **CAUTION** //////////////////////

**The adjusting screws on the temperature control device have very sensitive response to adjustment. DO NOT attempt to adjust the screw until after thoroughly reading and understanding the instructions and illustrations. Over-adjusting or erratic guessing, can foul the instrument and cause ultimate delay and part replacement, WHICH COULD HAVE BEEN PREVENTED.**

////////////////////////////////////

**GENERAL ELECTRIC  
ADJUST  
RANGE SCREW**

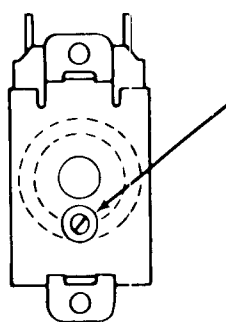

ROTATE CCW



**ROBERTSHAW  
ADJUST  
RANGE SCREW**

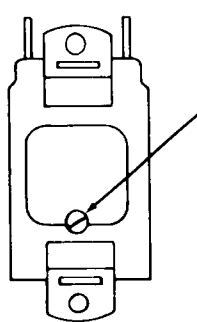

ROTATE CW



**RANCO  
ADJUST  
RANGE SCREW  
(BEHIND PANEL, TOP SIDE)**

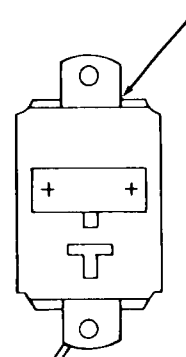

ROTATE CW



*Adjustment of the Temperature Control*

# THE PARTS ILLUSTRATIONS AND PARTS LISTS

## GENERAL

This section contains the Parts Illustrations and the Parts List for each of the major assemblies of the Model MH750 Ice maker.

A *No Number* designation, when used in the Part Number Column indicates the unit is not available from SCOTSMAN as an assembly. This designation is used only for the convenience and clarity of division in cataloging.

## HOW TO ORDER PARTS OR ASSEMBLIES

When ordering parts or assemblies, to avoid costly delays and errors in shipment, give the part number, the complete description shown in the list, and the quantities of each part or assembly required. Also include the Model name, the serial number of the Ice maker for which the part is required, and for parts which require color matching, the color of the Cabinet.

## IMPORTANT

All Part Numbers have TEN DIGITS (spaces), required for use in the Computer System. BE SURE to fill in ALL SPACES in the CATALOG NUMBER column, on the Parts Order form.

Enter the QUANTITY of the Parts ordered, in the last digit column under the QUANTITY column heading, the one under the small 55 number, for parts from 1 thru 9. For 10 or more parts use two columns.

To be sure you receive the proper parts in the proper quantities, ALWAYS use the PART NUMBERS and DESCRIPTIONS given in the Parts Manuals.

Write an order for the Part. (Use SCOTSMAN Parts Order Form DN103). Be sure to include:

- Distributor Name.
- (Use for DROP-SHIP order ONLY.)
- Distributor Purchase Order Number.
- Carrier.
- How shipped (Truck, Rail, UPS, etc.)
- Date ordered.
- Part Catalog Number. (Use full TEN digits (spaces) listed in Parts Manual, including dashes between numbers.)
- Description — as listed in Parts Manual.
- Quantity — number of parts ordered. (Use far right column.)

# WIRING DIAGRAMS

This Section is provided as an aid in understanding the electrical circuitry of the Ice Making System.

The Wiring Diagrams in the Section are:

- Air-Cooled Models 100-120/60/1, 200-240/60/1
- Water-Cooled Models 100-120/60/1, 200-240/60/1

## ////////////////////// WARNING ////////////////////////

**When conducting a continuity check of the Ice Making System:**

1. Disconnect the main power source.
2. **DO NOT use an incandescent lamp or jumper wire, conduct all tests with a volt-ohm-meter.**

////////////////////////////////////

# MH750 THE PARTS ILLUSTRATIONS AND PARTS LISTS

Item Number	Part Number	Description
1	A30007-002	PANEL TOP - (C.R.S. PAINTED)
	A30007-001	PANEL TOP (STAINLESS STEEL)
		ATTACHING PARTS, INDEX 1
	03-1417-15	LOCKWASHER, NO. 8 COUNTERSUNK EXTERNAL TOOTH
	03-1419-09	SCREW, NO. 8 x 1-1/4 FLAT HD S/T
	03-1423-06	SPEEDNUT - (J-TYPE)
2	A30010-002	PANEL, REAR - (C.R.S. PAINTED)
	A30010-001	PANEL, REAR - (STAINLESS STEEL)
		ATTACHING PARTS, INDEX 2
	03-1417-03	LOCKWASHER, NO. 8 EXTERNAL TOOTH
	03-1404-09	SCREW, NO. 8 x 1/2 T/F TAP
3	A30009-002	PANEL, RIGHT SIDE - (C.R.S. PAINTED)
	A30009-001	PANEL, RIGHT SIDE - (STAINLESS STEEL)
		ATTACHING PARTS, INDEX 4
	03-1417-03	LOCKWASHER, NO. 8 EXTERNAL TOOTH
	03-1404-09	SCREW, NO. 8 x 1/2 T/F TAP
4	03-1507-00	SPEEDNUT
	A30006-002	PANEL, FRONT - (C.R.S. PAINTED)
	A30006-001	PANEL, FRONT - (STAINLESS STEEL)
		ATTACHING PARTS, INDEX 5
	03-1417-15	LOCKWASHER, NO. 8 COUNTERSUNK EXTERNAL TOOTH
	03-1419-09	SCREW, NO. 8 x 1-1/4 FLAT HD S/T
5	03-1423-06	SPEEDNUT - (J-TYPE)
	15-0718-01	SCOTSMAN EMBLEM
	03-0271-00	SPEED CLIPS
	A30008-002	PANEL, LEFT SIDE - (C.R.S. PAINTED)
	A30008-001	PANEL, LEFT SIDE - (STAINLESS STEEL)
		ATTACHING PARTS, INDEX 3
6	03-1417-03	LOCKWASHER, NO. 8 EXTERNAL TOOTH
	03-1404-09	SCREW, NO. 8 x 1/2 T/F TAP
	03-1507-00	SPEEDNUT
	<i>No Number</i>	SHIELD, WIRE
		ATTACHING PARTS, INDEX 6
	03-1404-09	SCREW, NO. 8 x 1/2 T/F TAP

# MH750 THE PARTS ILLUSTRATIONS AND PARTS LISTS

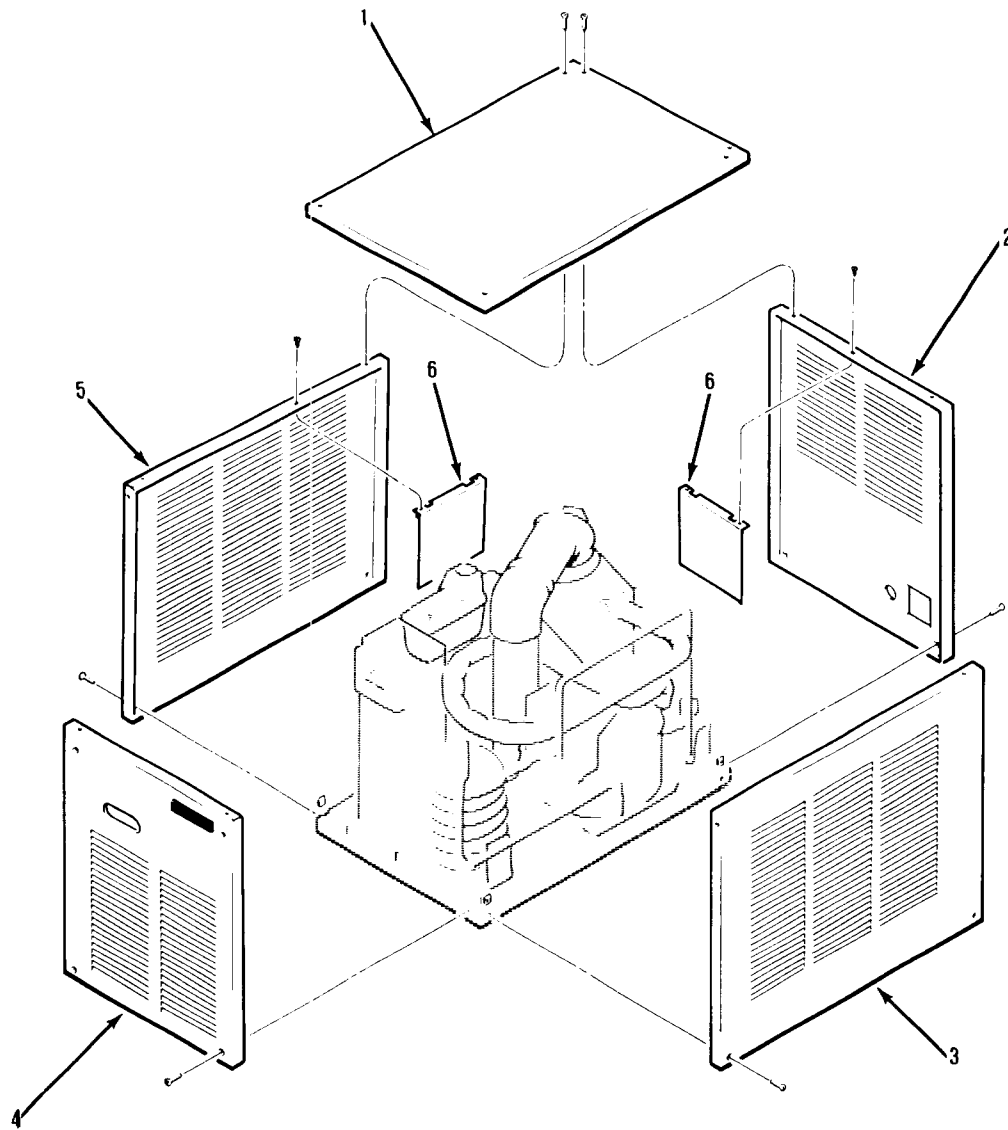

*Model MH750 Cabinet*



# MH750

## THE PARTS ILLUSTRATIONS AND PARTS LISTS

Item Number	Part Number	Description
1	No Number	ELBOW & SWITCH HOUSING
2	02-2604-01	BRACKET SPOUT RETAINER
		ATTACHING PARTS, INDEX 2
	03-1544-04	SCREW 10-24 x 3/8 STAINLESS SOC HD CAP
3	13-0617-45	"O" RING
4	No Number	FREEZER ASSEMBLY
		ATTACHING PARTS, INDEX 4
	03-1408-03	WASHER 5/16 PLAIN (STAINLESS)
	03-1420-03	SCREW 5/16-18 x 1-1/4 HEX CAP
5	13-0704-00	GASKET
6	A29463-001	ADAPTER, FREEZER
7	02-2577-01	ADAPTER (LARGE)
8	No Number	DRIVEMOTOR ASSEMBLY
		ATTACHING PARTS, INDEX 8
	03-1417-12	LOCKWASHER 5/16 EXTERNAL TOOTH
	03-1405-38	SCREW 5/16 - 18 x 3/4 HEX CAP
9	11-0296-00	CONTROL LOW PRESSURE (WATER)
		ATTACHING PARTS, INDEX 9
	03-1409-21	RUBBER WASHER
10	No Number	BAFFLE WATER CONT
		ATTACHING PARTS, INDEX 10
	03-1404-09	SCREW #8 x 1/2
11	A27993-001	BRACKET, UTILITY
		ATTACHING PARTS, INDEX 11
	03-1360-01	SCREW 10-16 x 3/4
12	No Number	COMPRESSOR
		ATTACHING PARTS, INDEX 12
	03-1405-20	SCREW 5/16-18 x 1-1/2 HEX CAP
	03-1417-12	LOCKWASHER 5/16 EXTERNAL TOOTH
	03-1408-29	WASHER 5/16 SPECIAL
	18-2200-27	SLEEVE
	18-2200-28	GROMMET
13	No Number	BAFFLE COMP CAP
		ATTACHING PARTS, INDEX 13
	03-1404-09	(2) SCREW 8 x 1/2
14	A28207-001	PLATE, MOTOR
		ATTACHING PARTS, INDEX 14
	03-1417-09	LOCKWASHER 1/4 EXTERNAL TOOTH
	03-0571-00	SCREW 1/4-20 x 1/2 T/C HEX HEAD
15	A30148-001	THERMO BRACKET
		ATTACHING PARTS, INDEX 15
		SCREW
16	A30195-001	TUBE
17	No Number	TUBE (RESERVOIR OVERFLOW DRAIN)
18	No Number	TUBE (RESERVOIR TO FREEZER INLET)
		ATTACHING PARTS, INDEXS 16, 17
	02-0534-00	(1) CLAMP (INDEX 16)
	02-0694-00	(2) CLAMP (INDEX 17)
19	A09388-001	BRACE DRIER
20	02-0544-01	DRIER
		ATTACHING PARTS, INDEXS 18, 19
	03-1403-35	SCREW 10-24 x 1-1/8 RESERVOIR PAN HD
	03-1406-06	NUT 10-24 HEX
21	A30002-001	BRACKET MOUNTING
		ATTACHING PARTS, INDEX 20
	03-1572-02	SCREW 8-18 x 1/2 PAN HD
22	02-2217-01	RESERVOIR
	02-2217-02	VALVE ASSEMBLY FLOAT (NOT SHOWN)
		ATTACHING PARTS, INDEX 21
	No Number	WING NUT (PART OF RESERVOIR)
23	A30088-001	TUBE
24	A30089-001	(2) U-CHANNEL
25	02-0179-03	(2) CLAMP, BAND

# MH750 THE PARTS ILLUSTRATIONS AND PARTS LISTS

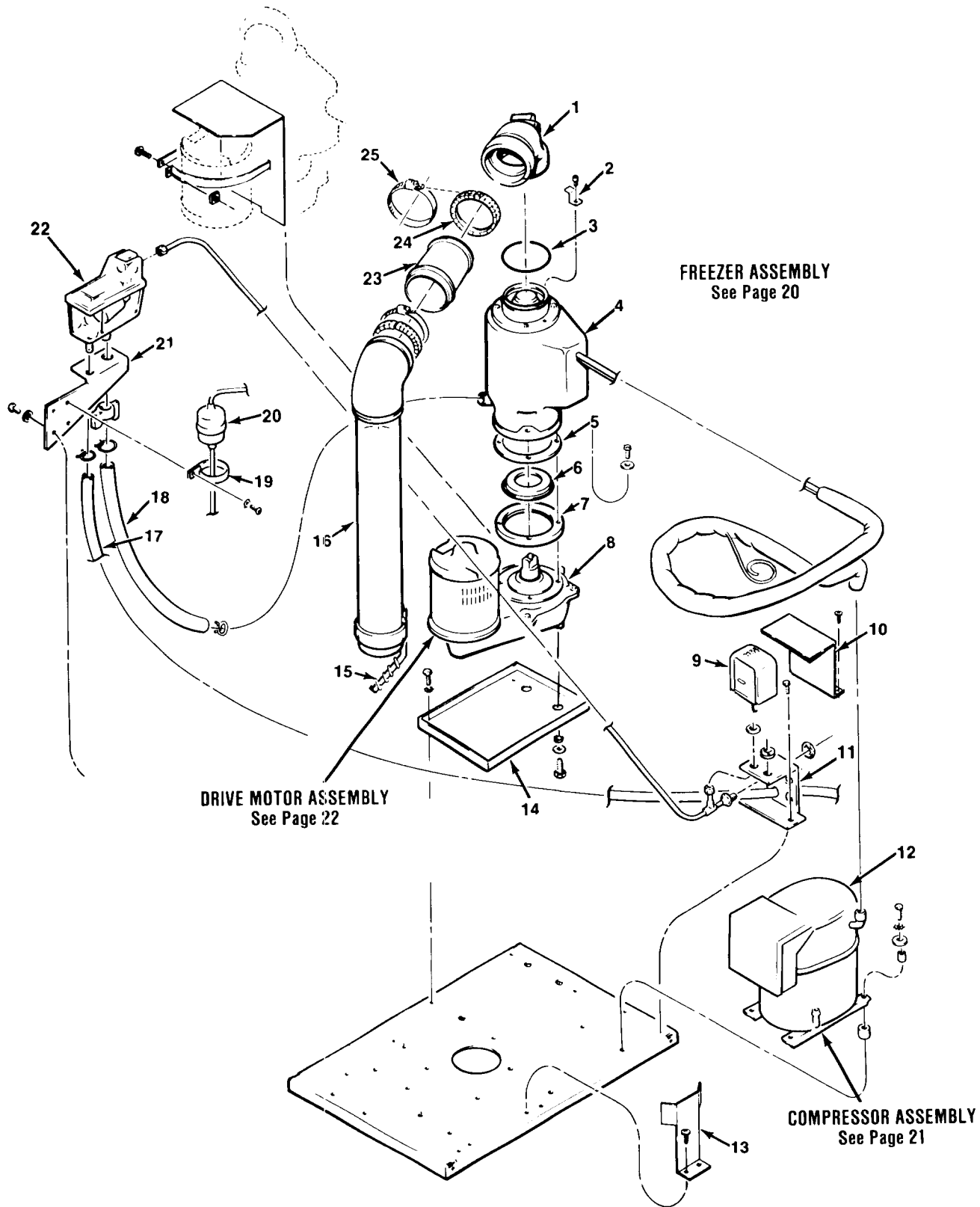

Major Assemblies

# MH750 THE PARTS ILLUSTRATIONS AND PARTS LISTS

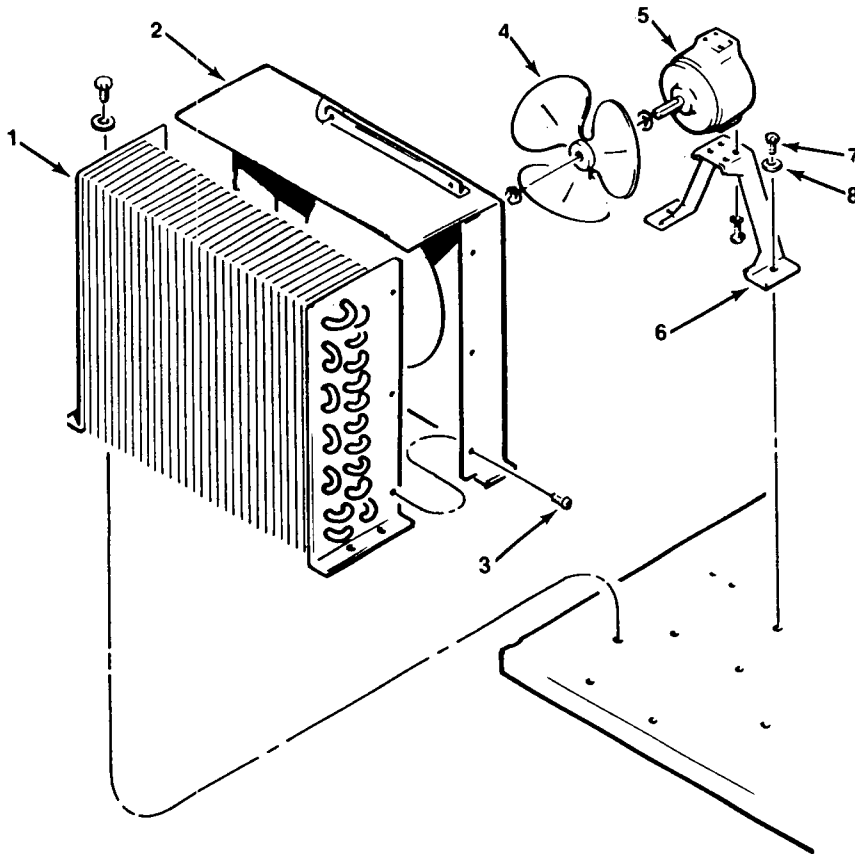

Item Number	Part Number	Description
1	18-0396-01	CONDENSER
2	A30003-001	SHROUD
3	03-1404-03	#6 x 1/4 (6)
4	18-0625-00	FAN BLADE AND NUT
5	18-0559-01	FAN MOTOR 115/60/1
	18-0559-00	FAN MOTOR 208-230/60/1
6	A25548-001	FAN MOUNTING BRACKET
7	03-0571-00	SCREW, THREAD CUTTING HEX HEAD 1/4-20 x 1/2-INCH (4)
8	03-1417-09	LOCKWASHER, INTERNAL TOOTH 1/4-INCH

*Air-Cooled Assemblies*

# MH750 THE PARTS ILLUSTRATIONS AND PARTS LISTS

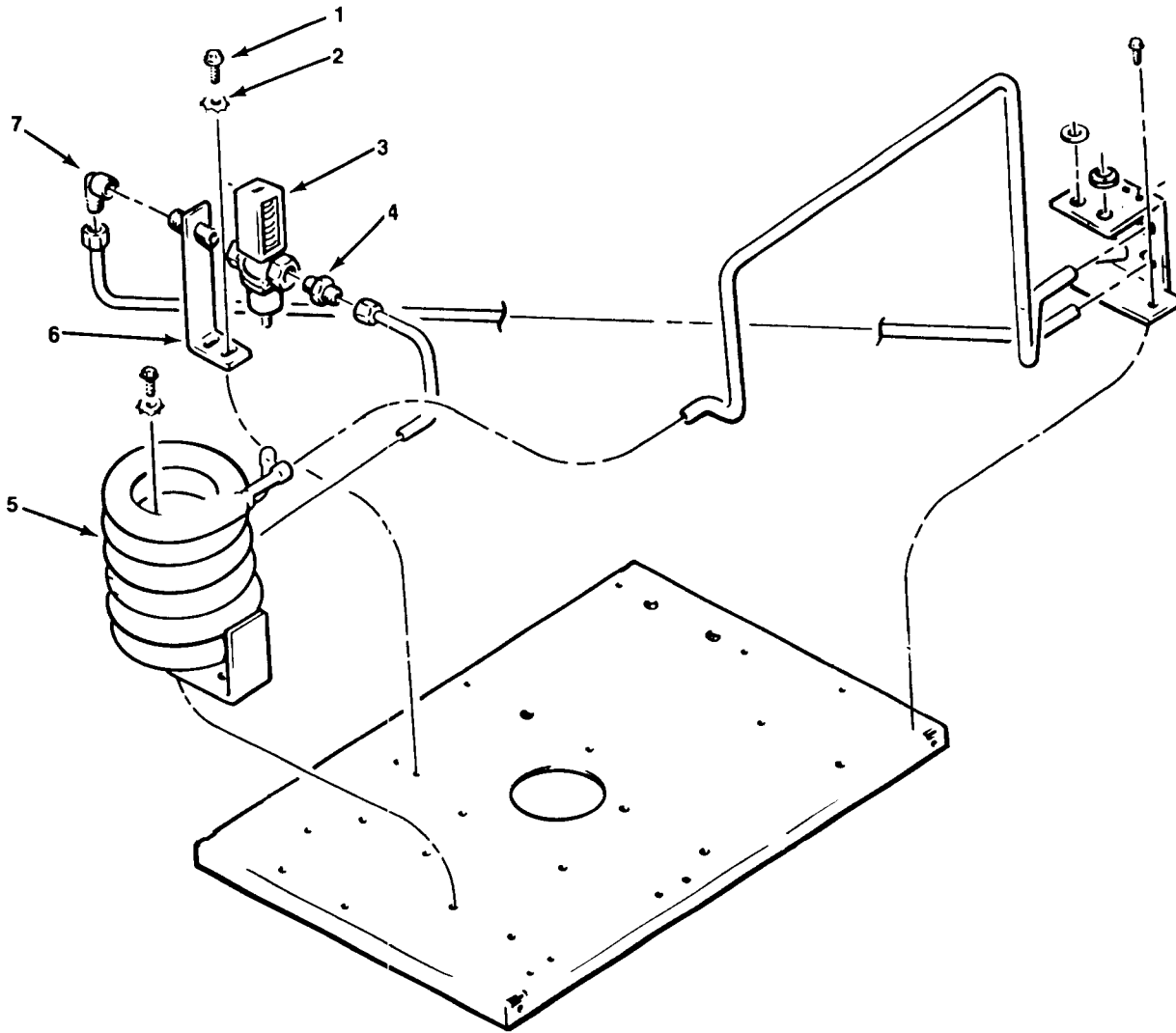

Item Number	Part Number	Description
1	03-0571-00	SCREW, 1/4-20 x 1/2 T/C HEX CAP
2	03-1417-09	LOCKWASHER, 1/4 INTERNAL TOOTH
3	11-0198-02	WATER REGULATOR
4	No Number	COUPLING
5	18-3305-02	CONDENSER ASSEMBLY
	ATTACHING PARTS, INDEX 5	
	03-0571-00	SCREW 1/4-20 x 1/2
	03-1417-09	LOCKWASHER 1/4
6	A15924-000	PIPE NIPPLE ASSEMBLY
7	No Number	ELBOW

*Water-Cooled Assemblies*

# MH750 THE PARTS ILLUSTRATIONS AND PARTS LISTS

NOTE: When replacing the following items

Item Number	Part Number	Description
1	12-2202-01	SWITCH
2	03-1403-08	SCREW, NO. 6-32 x 7/8
3	03-0886-00	SPEEDNUT
4	02-2764-01	ELBOW ASSEMBLY
5	02-2604-01	BRACKET, SPOUT RETAINING
6	03-1544-04	SCREW, NO. 10-24 x 3/8
7	02-2637-01	RETAINING RING
8	02-2778-02	INSULATION LEFT SIDE
9	02-2778-01	INSULATION RIGHT SIDE

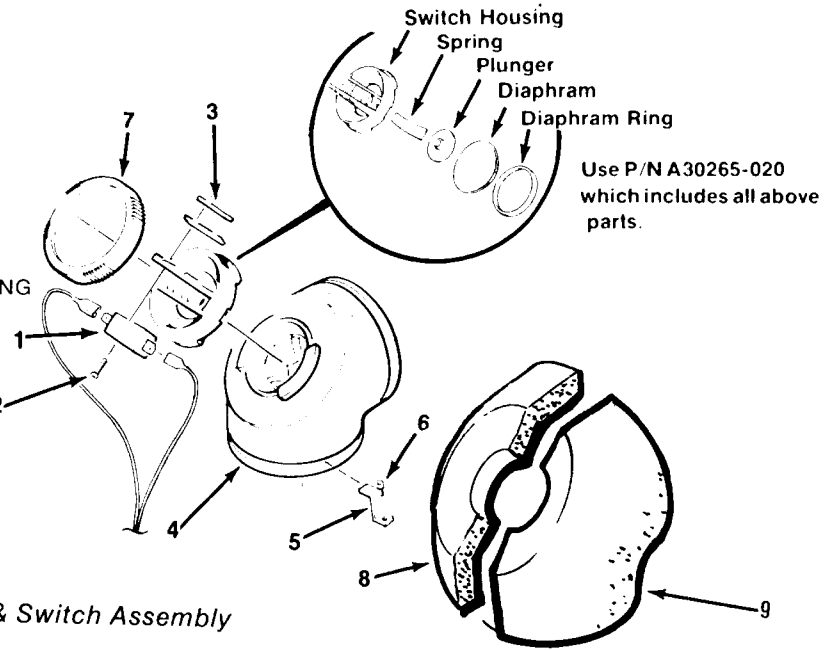

*Elbow & Switch Assembly*

Item Number	Part Number	Description
1	A29432-020	ICE BREAKER ASSEMBLY
		ATTACHING PARTS, INDEX 1
1a	03-1405-42	SCREW 5/16 - 18 x 7/8 HEX CAP
1b	03-1417-13	LOCKWASHER 5/16 HELICAL SPRING
1c	No Number	ICE BREAKER
1d	02-1683-00	BEARING
1e	02-1607-01	SEAL, OIL
2	13-0617-46	O-RING
3	A29824-001	AUGER
4	02-0929-01	SEAL, WATER
5	A29990-020	FREEZER ASSEMBLY

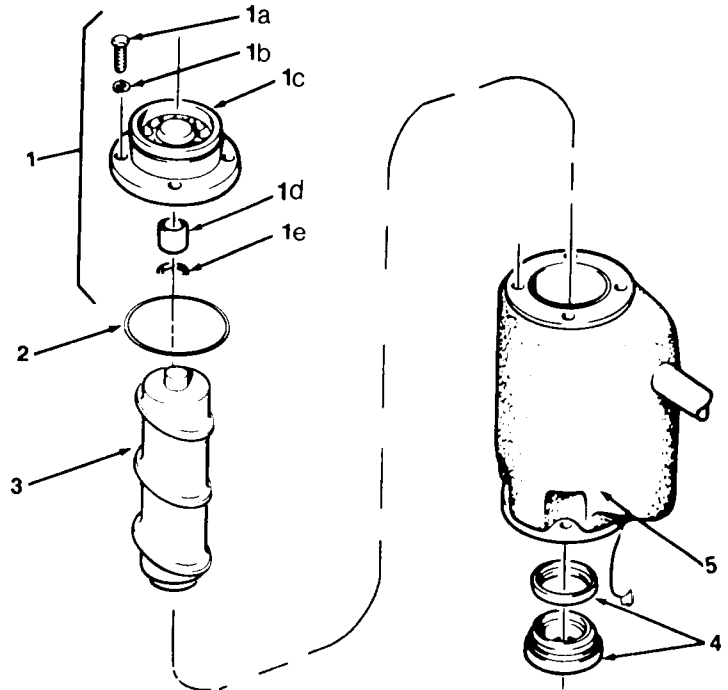

*Freezer Assembly*

# MH750 THE PARTS ILLUSTRATIONS AND PARTS LISTS

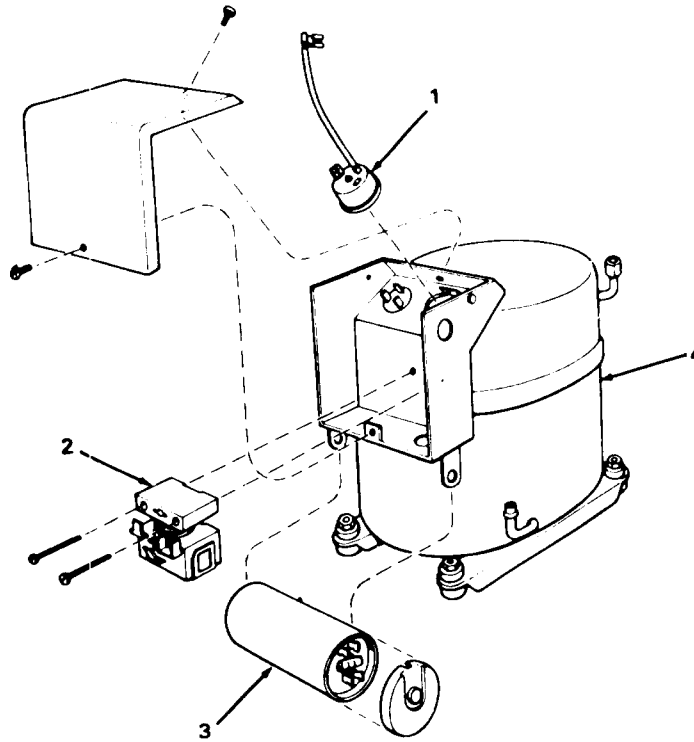

Item Number	Part Number	Description
1	18-2400-25	OVERLOAD (115/60/1)
	18-2400-26	OVERLOAD (208-230/60/1)
2	18-2410-00	RELAY (115/60/1)
	18-2200-34	RELAY (208-230/60/1)
3	18-2420-00	CAPACITOR (115/60/1) WITH CAP
	18-2421-00	CAPACITOR (208-230/60/1) WITH CAP
4	18-3900-01	COMPRESSOR ASSEMBLY (115/60/1)
	18-3900-02	COMPRESSOR ASSEMBLY (208-230/60/1)

## *Compressor Assembly*

# MH750 THE PARTS ILLUSTRATIONS AND PARTS LISTS

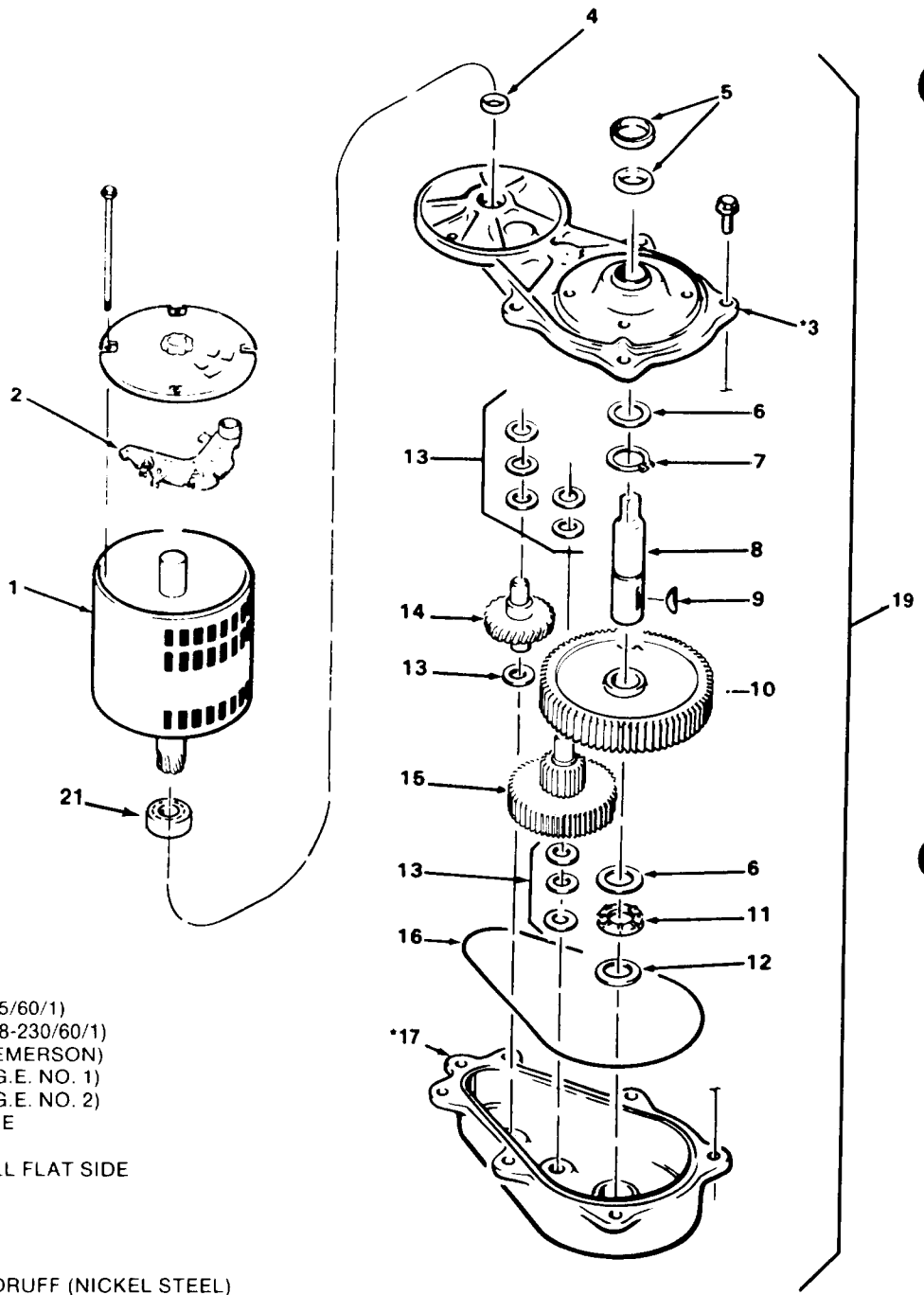

## DRIVEMOTOR ASSEMBLY

Item Number	Part Number	Description
1	A26455-001	DRIVE MOTOR (115/60/1)
	A26455-002	DRIVE MOTOR (208-230/60/1)
2	12-1741-22	SWITCH, START (EMERSON)
	12-1741-28	SWITCH, START (G.E. NO. 1)
	12-1741-32	SWITCH, START (G.E. NO. 2)
3*	A30391-001	COVER, GEARCASE
4	02-1606-00	SEAL, OIL
5	02-1607-00	SEAL, OIL (INSTALL FLAT SIDE TO FLAT SIDE)
6	02-1679-00	RACE, THRUST
7	03-1363-00	RING, RETAINING
8	02-2541-01	SHAFT, OUTPUT
9	03-1630-01	KEY, NO. 91 WOODRUFF (NICKEL STEEL)
10	02-2745-01	GEAR, OUTPUT
11	02-1680-00	BEARING
12	02-1679-00	RACE, THRUST
13	03-1408-24	WASHER
14	02-1603-00	SECOND PINION ASSEMBLY, FIRST GEAR AND
15	02-1604-00	THIRD PINION ASSEMBLY, SECOND GEAR AND
16	A26103-001	O-RING (8.92 INCH DIA.)
17*	A30391-001	CASE ASSEMBLY
18	03-1251-01	SCREW, NO. 5/16-18-1 FLANGE
19	A29410-021	COMPLETE GEARCASE REDUCER ASSEMBLY 115/60/1
	A29410-022	COMPLETE GEARCASE REDUCER ASSEMBLY 230/60/1
20	A25835-001	GEARCASE OIL (1 PINT CAN) Not Shown
21	12-1741-29	ROTOR BEARING

**\*NOTE:** Gearcase cover and bottom are sold as a set only. Order part number A30391-001.

*Drivemotor Assembly — MH750 1/4 H.P.*

# MH750

## THE PARTS ILLUSTRATIONS AND PARTS LISTS

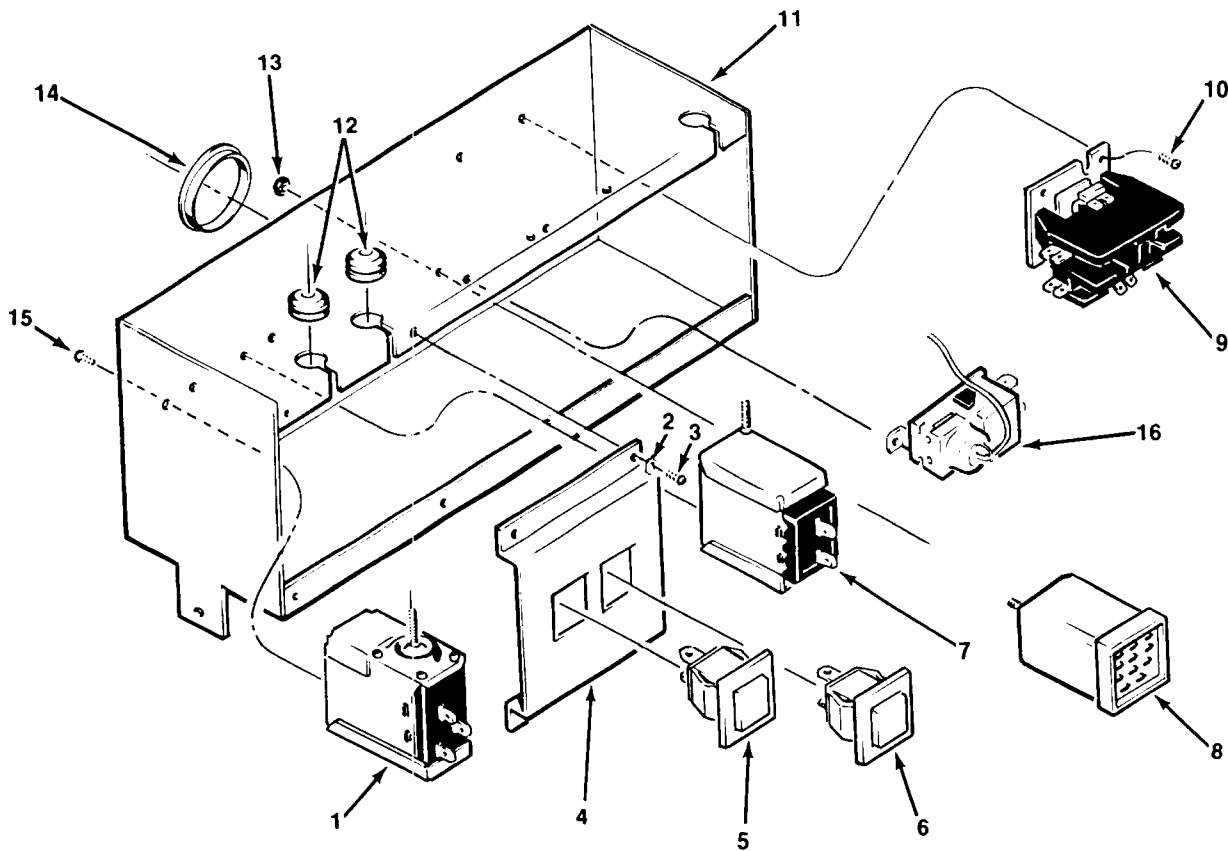

Item Number	Part Number	Description
1	11-0402-01	AUGER DELAY
2	03-1417-03	LOCK WASHER
3	03-1531-01	SCREW NO. 8 x 3/8
4	A30543-001	SWITCH HOUSING
5	12-2199-02	SWITCH, START-RESET 208-230/60/1
	12-2199-01	SWITCH, START-RESET 115/60/1
6	12-2200-02	SWITCH, ON-OFF 208-230/60/1
	12-2200-01	SWITCH, ON-OFF 115/60/1
7	11-0420-01	CONTROL, LO PRESSURE
8	12-2090-04	RELAY 208-230/60/1
	12-2090-01	RELAY 115/60/1
9	12-2037-02	CONTACTOR 208-230/60/1
	12-2037-01	CONTACTOR 115/60/1
10	03-1403-17	SCREW NO. 8 x 3/8
11	No Number	CONTROL BOX
12	13-0557-00	GROMMET
13	03-1406-01	NUT
14	12-1213-12	SNAP BUSHING
15	03-1403-02	SCREW 6 x 1/4
16	11-0354-00	BIN THERMOSTAT

*Control Box Assembly — MH750 Air-Cooled*



# MH750 THE PARTS ILLUSTRATIONS AND PARTS LISTS

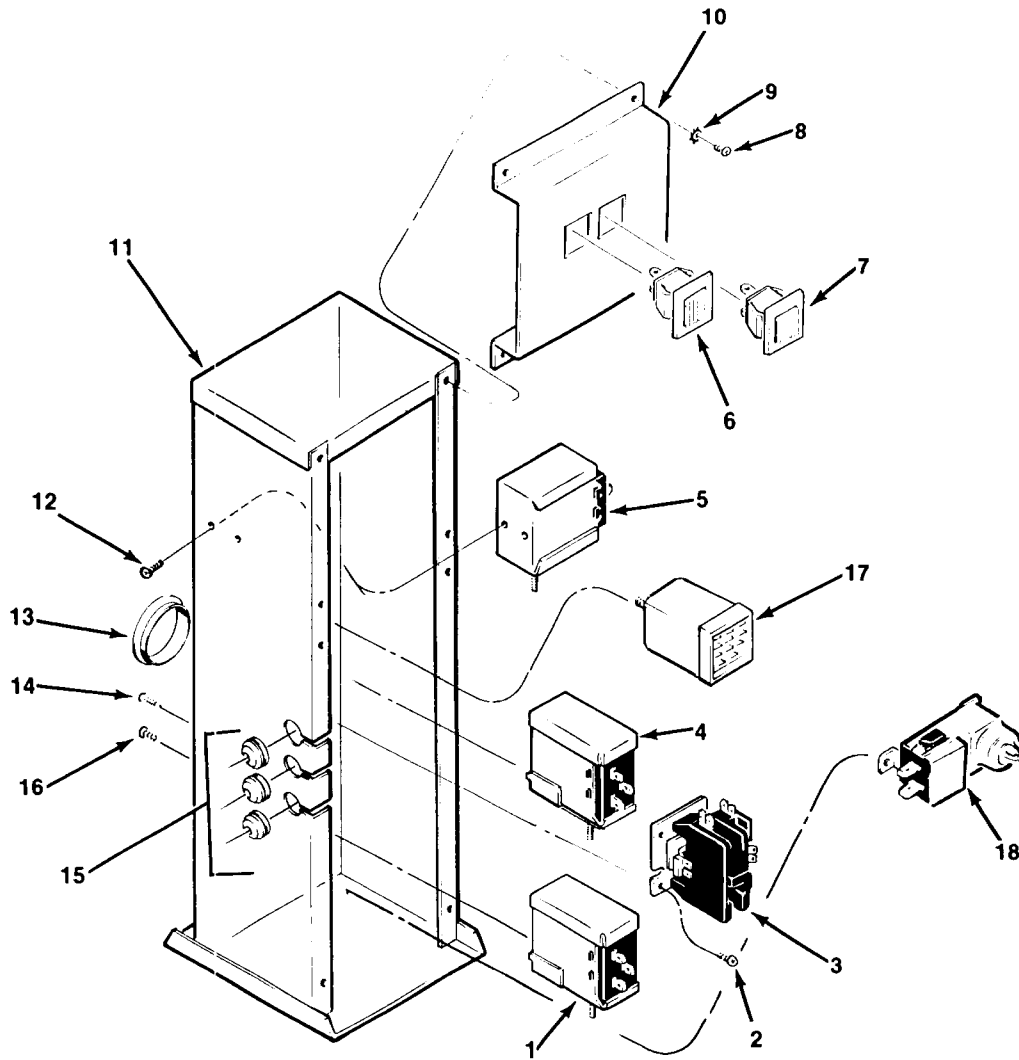

Item Number	Part Number	Description
1	11-0420-01	CONTROL LO PRESSURE
2	03-1403-17	SCREW NO. 8 x 3/8
3	12-2037-01	CONTACTOR 115/60/1
	12-2037-02	CONTACTOR 208-230/60/1
4	11-0402-01	AUGER DELAY
5	11-0388-02	CONTROL HI PRESSURE
6	12-2199-01	SWITCH, START-RESET 115/60/1
	12-2199-02	SWITCH, START-RESET 208-230/60/1
7	12-2200-01	SWITCH, ON-OFF 115/60/1
	12-2200-02	SWITCH, ON-OFF 208-230/60/1
8	03-1531-01	SCREW
9	03-1417-03	LOCK WASHER
10	A30543-001	SWITCH HOUSING
11	No Number	CONTROL BOX
12	03-1403-02	SCREW
13	12-1213-10	SNAP BUSHING
14	03-1403-02	SCREW
15	13-0557-00	GROMMET
16	03-1403-02	SCREW
17	12-2090-01	RELAY 115/60/1
	12-2090-04	RELAY 208-230/60/1
		ATTACHING PARTS
	03-1417-01	LOCK WASHER
	03-1406-01	NUT 6-32
18	11-0354-00	BIN THERMOSTAT

*Control Box Assembly — MH750 Water-Cooled*

# MH750 WIRING DIAGRAMS

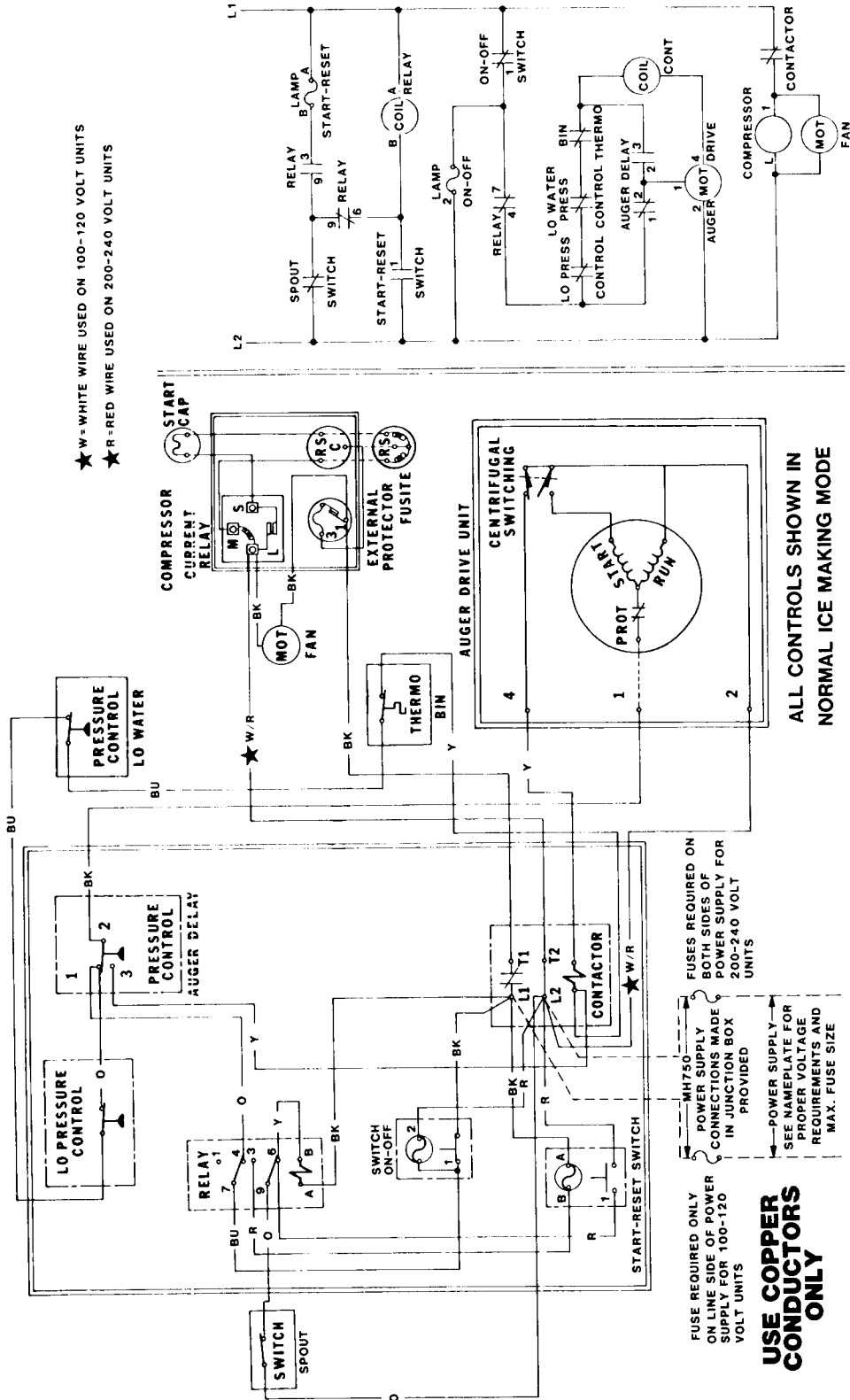

Wiring Diagram — Air-Cooled 115/60/1 and 230/60/1

# MH750 WIRING DIAGRAMS

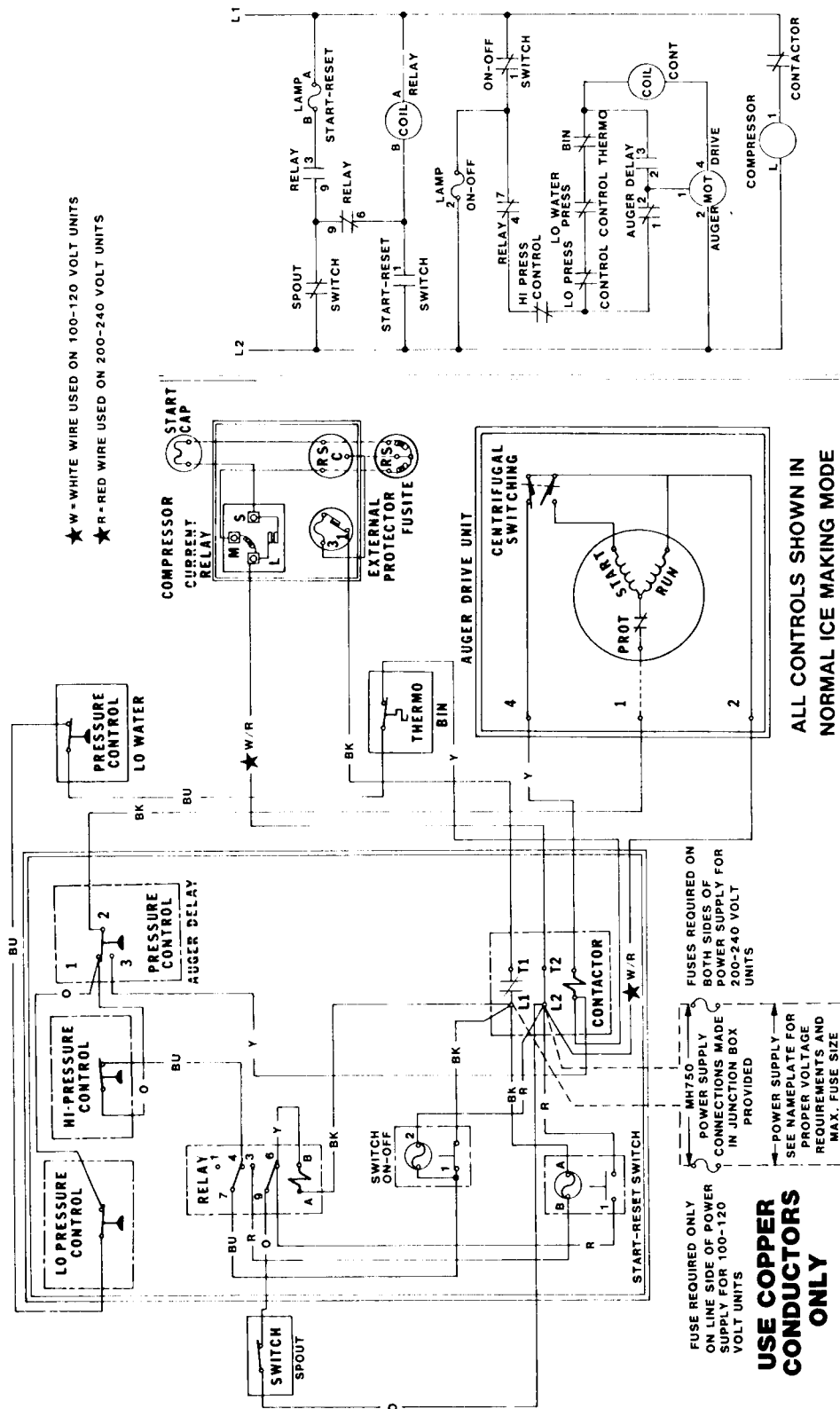

★ W - WHITE WIRE USED ON 100-120 VOLT UNITS  
 ★ R - RED WIRE USED ON 200-240 VOLT UNITS

ALL CONTROLS SHOWN IN  
 NORMAL ICE MAKING MODE  
**THIS UNIT MUST BE GROUNDED**

**USE COPPER CONDUCTORS ONLY**

FUSE REQUIRED ONLY ON LINE SIDE OF POWER SUPPLY FOR 100-120 VOLT UNITS

FUSES REQUIRED ON BOTH SIDES OF POWER SUPPLY FOR 200-240 VOLT UNITS

MH750 POWER SUPPLY CONNECTIONS MADE IN JUNCTION BOX PROVIDED

POWER SUPPLY - SEE NAMEPLATE FOR PROPER VOLTAGE REQUIREMENTS AND MAX. FUSE SIZE

**A31050-001**

Wiring Diagram — Water-Cooled 115/60/1 and 230/60/1





# MH750 ADJUSTMENT AND REMOVAL AND REPLACEMENT

## ADJUSTMENT OF THE WATER REGULATOR ASSEMBLY — WATER-COOLED MODELS

To adjust the water regulator assembly:

1. To INCREASE the head pressures: Rotate the adjusting screw, on the water regulator assembly COUNTERCLOCKWISE.
2. To DECREASE the head pressure: Rotate the adjusting screw, on the water regulator assembly CLOCKWISE.

## ADJUSTMENT OF THE WATER RESERVOIR FLOAT

The correct water level in the water reservoir should be at the level of the raised molded line, on the side of the body of the water reservoir. When the water level is above or below the raised molded line, adjustment can be performed to raise or lower the water level by bending the metal arm of the float, inside the water reservoir.

To adjust the water reservoir float:

1. To RAISE the water level:  
Hold one end of the metal arm of the float and slightly bend the float up.
2. To LOWER the water level:  
Hold one end of the metal arm of the float and slightly bend the float DOWN.
3. To perform MAJOR adjustment:  
When repair or replacement has been performed and the water level line between the water reservoir and the freezer assembly has been substantially altered:
  - a. Loosen the three screws and lockwashers which attach the reservoir bracket and water reservoir to the freezer mount.
  - b. Move the reservoir bracket UP or DOWN to properly position the water reservoir at the correct water line level within the freezer. The proper water level within the freezer is 1/2" to 3/4" below the top of the auger.
  - c. When proper water level within the freezer is adjusted, re-tighten screws attaching the water reservoir bracket to the freezer mount.

## REMOVAL AND REPLACEMENT OF THE AUGER, WATER SEAL, BEARINGS AND ICE BREAKER

### ////////// WARNING //////////

**Be sure the electrical power supply to the icemaker is OFF before proceeding with removal procedures.**

### ////////// //////////

Auger, water seal, bearing and ice breaker are located in the freezer assembly.

1. Close the water inlet valve to the icemaker and drain the float chamber and freezer.
2. Remove screw and remove switch support from side panel. Remove elbow insulation.
3. Remove three Allen head screws and spout retaining brackets from the elbow and switch assembly. Lift and rotate elbow and switch assembly and remove elbow from ice breaker.
4. Remove bolts and washers and remove ice breaker from the freezer assembly.
5. Remove O-ring seals. Inspect for cuts or wear. Replace if worn.
6. Clean away the old grease from the top of the auger, and from the oil lip seal, and bearing in the ice breaker.
7. Inspect the bearing pressed into the ice breaker assembly and if it is to be replaced, remove the oil lip seal and remove the bearing.

### NOTE

*Replace seal if auger is removed. Anytime the auger is removed for inspection of water seal, use extra care in handling the water seal parts, so dirt or foreign matter are not deposited on the surfaces of the seal.*

*If there is any doubt about the effectiveness of the O-ring, REPLACE IT. A dirty, worn or faulty O-ring will cause a leak and ultimately require a second, time consuming removal and replacement procedure to be performed, that COULD HAVE BEEN PREVENTED.*

8. Thread suitable length bolt, having No. 5/16-18 UNC-2B threads, into thread hole in the top of the auger.

# MH750 ADJUSTMENT AND REMOVAL AND REPLACEMENT

## NOTE

*At the serviceman's discretion, the auger can be removed using a slide-hammer and adaptor combination device; or, a simple metal bar, or wood plank, with a hole drilled through the middle, larger than the bolt diameter, placed across the top of the opening to the freezing chamber. With a large flat washer, the bolt is inserted through the washer and hole in the bar or plank, and as the bolt is tightened, in the threads of the auger, it will slowly pull the auger loose and out of the chamber.*

9. Remove the auger from the freezing chamber and slide the upper half of the water seal off of the bottom of the auger.
10. Remove four hex cap screws and washers which attach the freezer assembly, gasket and adaptors to the drivemotor assembly.
11. Raise the freezer assembly and temporarily secure the freezer assembly out of the way, to gain access and allow room to work. Be careful not to damage the gasket.
12. Using a suitable length and size wooden dowel or stick inserted through the top of the open freezer assembly, tap the lower half of the water seal out the bottom of the freezer assembly.
13. Always replace the water seal if the auger has been removed from the freezing chamber.

To replace the Auger, reverse the removal procedures.

## REMOVAL AND REPLACEMENT OF THE COMPRESSOR ASSEMBLY

### ////////// WARNING //////////

**Be sure the electrical power supply to the icemaker is OFF before proceeding with removal procedures.**

### ////////// //////////

To remove compressor:

1. Remove two screws and the cover from the compressor junction box.
2. Disconnect the electrical leads at the compressor junction box, that originate in the control box and fan motor.
3. Bleed off or blow the refrigerant charge through the Schrader valve.
4. Unsolder the suction line from the compressor.
5. Unsolder the discharge line from the compressor.

6. Unsolder the process header tube from the compressor and retain for installation on the replacement compressor.
7. Remove four bolts, lockwashers and washers which secure the compressor to the chassis mounting base.
8. Remove the compressor from the chassis.
9. To replace the compressor assembly, reverse the removal procedures.

## NOTE

*Always install a replacement drier, anytime the sealed refrigeration system is opened. Do not replace the drier until all other repair or replacement has been completed.*

## NOTE

*Thoroughly evacuate the system to remove moisture and non-condensables.*

10. When recharging the system with refrigerant, always check the nameplate for the specified refrigerant charge.

## REMOVAL AND REPLACEMENT OF THE CONDENSER — AIR-COOLED MODELS

To remove the condenser:

1. Bleed off or blow the refrigerant charge through the Schrader valve.
2. Remove one screw and disconnect the drier brace and drier from the condenser shroud.
3. Unsolder and disconnect the condenser inlet tube at the condenser.
4. Unsolder and disconnect the condenser outlet tube at the condenser.
5. Remove three screws, lockwashers and washers securing the condenser to the chassis base.
6. Remove four screws that attach the control box to the condenser.
7. Remove the condenser from the chassis base.
8. To replace the condenser, reverse the removal procedure.

## NOTE

*Always install a replacement drier, anytime the sealed refrigeration system is opened. Do not replace the drier until all other repair or replacement has been completed.*

# MH750 ADJUSTMENT AND REMOVAL AND REPLACEMENT

## NOTE

*Thoroughly evacuate the system to remove moisture and non-condensables.*

9. When recharging the system with refrigerant always check nameplate for the specified refrigerant charge.

## REMOVAL AND REPLACEMENT OF THE CONDENSER — WATER-COOLED MODELS

To remove the water-cooled condenser:

1. Remove two screws and cabinet left front panel.
2. Bleed or blow the refrigerant charge through the Schrader valve.
3. Close the water inlet valve to the icemaker.
4. Unsolder the refrigerant inlet and outlet lines from the condenser.
5. Disconnect the water inlet and outlet lines from the condenser.
6. Remove two bolts, lockwashers and washers which secure the condenser to the chassis mounting base.
7. Remove the condenser from the cabinet.
8. To replace the condenser, reverse the removal procedure.

## NOTE

*Always install a replacement drier, anytime the sealed refrigeration system is opened. Do not replace the drier until all other repair or replacement has been completed.*

## NOTE

*Thoroughly evacuate the system to remove moisture and non-condensables.*

9. When recharging the system with refrigerant always check nameplate for the specified refrigerant charge.

## REMOVAL AND REPLACEMENT OF THE LIQUID LINE DRIER

To remove the drier:

1. Remove screw and drier brace attaching the drier to the condenser shroud on air-cooled models; and, the chassis base on water-cooled models.
2. Bleed off or blow the refrigerant charge through the Schrader valve.

3. Unsolder refrigerant lines at top and bottom of drier, remove the drier and separate the drier from the drier brace.

To replace the drier:

1. Remove the factory seals from the replacement drier and install the drier in the refrigerant lines with the arrow positioned in the direction of the refrigerant flow.

## CAUTION

**If the factory seal is broken on the replacement drier, exposing it to the atmosphere more than a few minutes, the drier will absorb moisture from atmosphere and lose substantial ability for moisture removal.**

**Be sure the replacement drier is installed with the arrow positioned in the direction of the refrigerant flow.**

2. Install the drier brace on the drier.
3. Solder the drier into the lines, two places.
4. Purge the system and check for leaks.
5. Thoroughly evacuate the system to remove moisture and non-condensables.
6. Charge the system with refrigerant by weight. SEE NAMEPLATE for specifications.

## REMOVAL AND REPLACEMENT OF THE DRIVEMOTOR ASSEMBLY

## WARNING

**Be sure the electrical power supply to the icemaker is OFF before proceeding with removal procedures.**

To remove the drivemotor assembly:

1. Remove the four screws and lockwashers from bottom of freezer assembly which fasten the freezer to the drivemotor assembly. Carefully lift the freezer off the gearmotor.
2. Remove the drivemotor cover and disconnect the three electrical wire leads.
3. Remove four screws that attach the gearmotor mounting plate to the ice machine base.
4. Remove three bolts, lockwashers and washers that attach the gearmotor to the mounting plate and remove the mounting plate.
5. Inspect the gearmotor and adapter housing(s) for signs of seal leakage. Replace the freezer water seal if leakage is evident.



# MH750 ADJUSTMENT AND REMOVAL AND REPLACEMENT

6. Clean the adapter housing(s).

To replace the gearmotor assembly, reverse the removal procedure.

## REMOVAL AND REPLACEMENT OF THE ELBOW AND SWITCH ASSEMBLY

### ////////// WARNING //////////

**Be sure the electrical power supply to the icemaker is OFF before proceeding with removal procedures.**

### ////////// //////////

To remove the elbow and switch assembly:

1. Disconnect the electrical supply to the icemaker at the circuit breaker or fuse box.
2. Close the inlet water valve to the icemaker.
3. Remove the front panel and the top panels. Remove the elbow and transport tube insulation.
4. Loosen the screw on the screw clamp and U-channel securing the ice transport tube to the elbow and safety switch and separate the ice transport tube from the elbow.
5. Remove screw and remove switch support from the side panel.
6. Remove three Allen head screws and spout retaining brackets from the freezer assembly and elbow and switch assembly.
7. Lift the elbow and switch assembly UP to clear the top of the freezer assembly.
8. Remove screws and the switch from the switch actuator housing.
9. Rotate the retainer ring 90-degrees to unlock the retainer ring and the switch actuator housing from the elbow assembly and separate the parts from the elbow.
10. Inspect the rubber diaphragm for cuts, tearing or excessive wear.

To replace the elbow and switch assembly, reverse the removal procedure.

## REMOVAL AND REPLACEMENT OF THE FAN MOTOR ASSEMBLY — AIR-COOLED MODELS

### ////////// WARNING //////////

**Be sure the electrical power supply to the icemaker is OFF before proceeding with removal procedures.**

### ////////// //////////

## NOTE

*Before beginning this procedure, observe the fan blade position on the shaft of the fan motor and mark the fan blade so it will be correctly positioned during reassembly. Direction of air flow should be toward the fan motor.*

To remove the fan motor assembly:

1. Disconnect the electrical supply to the icemaker at the circuit breaker or fuse box.
2. Remove four screws and the front panel.
3. Remove screws and the top panel.
4. Disconnect the electrical lead from the fan motor at the compressor control box.
5. Remove two screws securing the motor bracket to the chassis base and remove the fan motor and motor bracket from the chassis.
6. Remove the nut from the end of the fan motor shaft and remove the fan blade.
7. Remove four screws securing the fan motor to the motor bracket and separate the motor from the bracket.

To replace the fan motor assembly, reverse the removal procedure.

## REMOVAL AND REPLACEMENT OF THE FREEZER ASSEMBLY

### ////////// WARNING //////////

**Be sure the electrical power supply to the icemaker is OFF before proceeding with removal procedures.**

### ////////// //////////

To remove the freezer assembly:

1. Disconnect the electrical supply to the icemaker at the circuit breaker or fuse box.
2. Close the inlet water valve to the icemaker.
3. Remove Tygon tube from the freezer assembly that connects to the water reservoir assembly.
4. Bleed off or blow the refrigerant charge through the Schrader valve.
5. Follow steps on removal and replacement of the auger, water seal, bearings and ice breaker.
6. Unsolder the suction line from the compressor.
7. Unsolder the capillary line at the drier.
8. Remove four screws, lockwashers and washers which attach the bottom of the freezer assembly to the drivemotor assembly.

# MH750 ADJUSTMENT AND REMOVAL AND REPLACEMENT

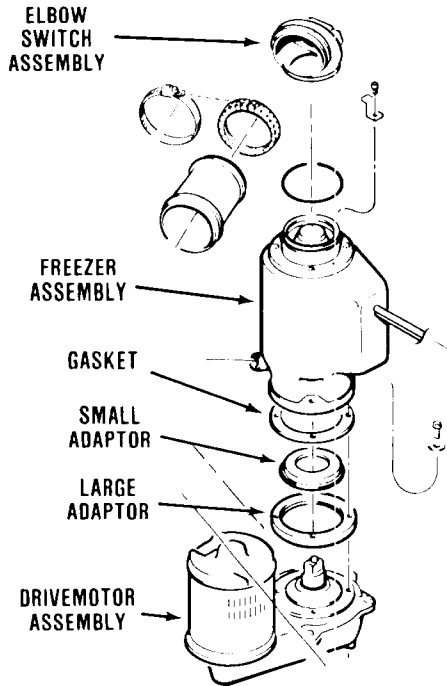

Removal of the Freezer Assembly

9. Lift the freezer assembly up and off of the drivemotor assembly.

To replace the freezer assembly, reverse the removal procedure.

### NOTE

*Always install a replacement drier, anytime the sealed refrigeration system is opened. Do not replace the drier until all other repair or replacement has been completed.*

### NOTE

*Thoroughly evacuate the system to remove moisture and non-condensables.*

10. Refer to name plate specifications and recharge refrigeration system by weight.

## REMOVAL AND REPLACEMENT OF THE WATER REGULATOR VALVE ASSEMBLY — WATER-COOLED MODELS

To remove the water regulator assembly refer to slide out chassis procedure and complete all steps.

1. Close the inlet water valve to the icemaker.
2. Bleed off or blow the refrigerant charge through the Schrader valve.
3. Unsolder the water regulator valve capillary tube from the discharge line process header.

4. Disconnect the water inlet and outlet lines from the water regulator valve.
5. Remove the two screws from the valve bracket to the machine base and remove the water regulator valve.
6. To replace the water regulator assembly, reverse the removal procedure.

### NOTE

*Always install a replacement drier, anytime the sealed refrigeration system is opened. Do not replace the drier until all other repair or replacement has been completed.*

### NOTE

*Thoroughly evacuate the system to remove moisture and non-condensables.*

7. Refer to name plate specifications and recharge refrigeration system by weight.

## REMOVAL AND REPLACEMENT OF THE WATER RESERVOIR ASSEMBLY

To remove the water reservoir:

### WARNING

**Be sure the electrical power supply to the icemaker is OFF before proceeding with removal procedures.**

### NOTE

*Be prepared with container to catch water left in lines disconnected in next steps to prevent draining water on parts, components, electrical lines, etc.*

1. Close the inlet water valve to the icemaker.
2. Disconnect the water inlet tube from the water reservoir assembly.
3. Remove two tubes from the bottom of the water reservoir assembly.
4. Unscrew and remove the wing nut from the bottom of the water reservoir assembly.
5. Lift and remove the water reservoir assembly from the mounting bracket.

To replace the water reservoir assembly, reverse the removal procedure.

# MH750 ADJUSTMENT AND REMOVAL AND REPLACEMENT

## NOTE

Check that the installed replacement water reservoir assembly float moves freely. Bend metal arm of float to adjust, as necessary. The correct water level in the water reservoir is the point of the raised molded line, on the side of the body of the water reservoir.

## REMOVAL AND REPLACEMENT OF THE LOW WATER PRESSURE SAFETY CONTROL ASSEMBLY

### ////////// WARNING //////////

Be sure the electrical power supply to the icemaker is OFF before proceeding with removal procedures.

//////////

1. Disconnect the electrical supply to the icemaker at the circuit breaker or fuse box.
2. Close the inlet water valve to the icemaker.
3. Remove screws and the right side panel.
4. Remove two screws and remove shield.
5. Disconnect electrical lead wires.
6. Using a back-up wrench, unscrew the low water pressure control from the unit.

To replace the low water pressure safety control, reverse the removal procedure.

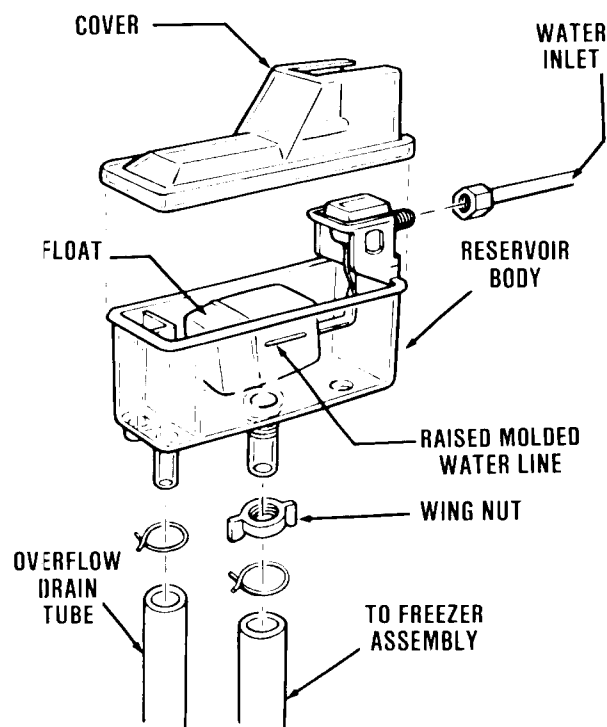

Removal of the Water Reservoir Assembly

## SERVICE DIAGNOSIS

The Service Diagnosis is for use in aiding the serviceman in diagnosing a particular problem for pin-pointing the area in which the problem lies, thus an ever available reference for proper corrective action.

The following charts list corrective actions for the causes of known symptoms of certain problems that can occur.

### INTRODUCTION

SYMPTOM	POSSIBLE CAUSE	CORRECTION
Water Leaks.	Defective water seal.	Replace seal.
	Gravity feed line leaking.	Check hose clamps.
	Water level in reservoir too high.	Adjust water level to molded line on the float assembly.
	Storage bin drain and connecting fittings.	Check and repair.
Excessive noise or chattering.	Mineral or scale deposit on auger and inner freezing chamber walls.	For severe deposit, remove and manually polish auger, sand inner chamber walls of freezer barrel.
		For lighter concentration, use Scotsman Ice Machine Cleaner periodically.
	Intermittent water supply.	Check and clean water strainer.
		Check gravity feed line for air lock.
	Water level in reservoir too low.	Check to be sure float orifice is not restricted.
		Check incoming water supply.
Making wet ice. (ice melts too quickly, is not cold enough to properly cure in the bin.)	Surrounding air temperature too high.	Correct or move cabinet.
	Under or over-charge of refrigerant.	Recharge with proper amount.
	Gear reducer loose on frame.	Tighten gear reducer.
	Motor compressor not solid on rubber mounts.	Repair or replace rubber mounts.
	Gearmotor end-play or worn bearing.	Repair or replace bearing.

## MH750 SERVICE DIAGNOSIS

SYMPTOM	POSSIBLE CAUSE	CORRECTION
Making wet ice (Cont'd)	Back pressure too high.	Overcharge of refrigerant, faulty compressor or high head pressure. Lower pressure as indicated.
	Faulty compressor.	Replace compressor.
Low ice production.	Loss of refrigerant. Under or over-charge of refrigerant.	Check and recharge. See NAME-PLATE for charge correction.
	Dirty or plugged condenser.	Clean condenser.
	Low water level in water reservoir.	See CORRECTION for water leaks above.
	Partial restriction in capillary tube or drier.	Moisture in system. Overcharge of oil in system. Remove charge by blowing back through cap tube. Replace drier, evacuate and recharge.
	Inlet water strainer partially plugged.	Remove screen and clean.
	Corroded or stained auger due to water condition.	Remove auger and clean, or use Scotsman Ice Machine Cleaner. See Maintenance Section.
Gearmotor noise.	Low on lubricant.	Remove case cover to check for proper lubricant level. Top of gears should be covered. Use: Sun Oil Company Prestige 50-EP
Icemaker will not operate.	Blown fuse in line.	Replace fuse and check for cause of blown fuse.
	Bin thermostat set too high.	Adjust thermostat. Set at 35-degrees cut-out, 45-degrees cut-in.
	Loose electrical connection.	Check wiring.
	Switch in OFF position.	Set switch to ON position.
	Inoperative master switch.	Replace switch or thermal overload.
	Off on hi-pressure manual-reset control. (Water-cooled only)	Reset.
	Low supply water pressure.	Restore water pressure.

# MH750 SERVICE DIAGNOSIS

SYMPTOM	POSSIBLE CAUSE	CORRECTION
Icemaker continues to operate with full storage bin.	Bin thermostat not properly set or is defective.	Re-set or replace bin thermostat. Re-set to 35-degrees cut-out, 45-degrees cut-in.
Compressor cycles intermittently.	Low voltage.	Check for overloading.
	Dirty condenser.	Clean condenser.
	Air circulation blocked.	Remove cause or move unit.
	Inoperative condenser fan motor.	Replace motor.
	Non-condensable gases in system.	Check for gas leaks, evacuate and recharge.
	Bin thermostat differential too small causing short cycling.	Widen differential 35-degrees cut-out, 45-degrees cut-in.
	Cycling on elbow switch.	Set or replace bin thermostat.
Icemaker operates but makes no ice.	Low on refrigerant causing low pressure control to cycle.	Check for leaks.
	Loss or undercharge of refrigerant.	Check for leaks and recharge. See NAMEPLATE for correct charge.
	Water not entering freezing chamber.	Plugged strainer or supply line. Check and clean. Air lock in gravity feed line. Check and remove air lock.
	Moisture in system.	Check, evacuate, replace drier. Recharge. See NAMEPLATE for correct charge.
	Water seal leaking. Drivemotor or drive coupling stripped.	Replace seal. Repair or replace drivemotor or drive coupling.
Red Start-Reset Light is on.	Bin Control failed.	Replace Bin Control
	Improperly installed Bin Control Bracket.	Install per directions on page 5.
	Power failure.	Inquire about power interruption.

# MAINTENANCE & CLEANING INSTRUCTIONS

## GENERAL

The periods and procedures for maintenance and cleaning are given as guides and are not to be construed as absolute or invariable. Cleaning especially will vary, depending upon local water conditions and the ice volume produced and, each icemaker must be maintained individually, in accordance with its own particular location requirements.

## ICEMAKER

THE FOLLOWING MAINTENANCE SHOULD BE SCHEDULED AT LEAST TWO TIMES PER YEAR ON THIS ICEMAKER. CALL YOUR AUTHORIZED SCOTSMAN SERVICE AGENCY.

1. Check and clean water line strainers.
2. Check that the water level in the water reservoir is at the water level on the side of the float.
3. Remove cover from water reservoir and depress the float to ensure that a full stream of water enters the reservoir.
4. Check that the icemaker is level, in side-to-side and front-to-rear directions.
5. Clean the water reservoir and interior of the freezer assembly, using a solution of SCOTSMAN Ice Machine Cleaner. Refer to CLEANING — Icemaker.

### NOTE

*Cleaning requirements vary according to local water conditions and individual user operation. Visual inspection of the auger before and after cleaning will indicate frequency and procedure to be followed in local areas.*

6. When doubtful about refrigerant charge, install refrigerant gauges on Schrader valves and check gauge for compressor head pressure:  
 AIR-COOLED MODELS: Varies between 130 and 145 PSIG.  
 WATER-COOLED MODELS: Set at 135 PSIG. Adjust screw on top of water regulator valve to raise or lower head pressure.
7. Check gauge for suction line pressure:  
 Varies between 8 to 12 PSIG, depending upon inlet water temperature and ambient air temperature.
8. Check drivemotor operation:  
 Normal operating temperatures are about 160-degrees F., which is hot to touch.

9. Check operation of the centrifugal sensing switch:

Switch will OPEN between 850-950 RPM and the compressor STOPS, with the drivemotor operating. Switch will CLOSE between 1100-1250 RPM and the compressor will RESTART, with drivemotor building back up to normal operating speed.

## ////////// WARNING //////////

**Disconnect electrical power supply before removal procedures.**

## //////////

10. Remove three Allen head screws and spout retaining brackets from the freezer assembly end of the elbow and switch assembly.
11. Lift the elbow and switch assembly and set aside to gain access to the top of the Freezer Assembly.
12. Remove four capscrews, lockwashers and the ice breaker assembly from the top of the freezer assembly for inspection.
13. Retain the O-Ring for replacement during reassembly. Inspect the O-ring for cuts, tears or excessive wear, causes for replacement.
14. Inspect the lip seal and the top bearing seated in the ice breaker, wipe clean of old grease and apply a coating of Taylor Freezer food grade grease, SCOTSMAN P/N 19-0569-01 or equivalent. Replace all parts removed in steps 10 thru 14.
15. Clean the air-cooled condenser, using vacuum cleaner, whisk broom or brush. Instruct customer to clean frequently and to be sure icemaker and fan motor are OFF.
16. Check that fan blades move freely, are not touching any surfaces and are not bent or out of balance.
17. Check for refrigerant leaks.
18. Check for water leaks. Pour water down bin drain to be sure that drain line is open and clear.
19. Check the quality of ice. Ice should be wet when formed, but will cure rapidly to normal hardness in the bin.
20. Check the bin thermostat control bulb.

# MH750 MAINTENANCE & CLEANING INSTRUCTIONS

## NOTE

*The bin thermostat is factory set at 10-degrees F. differential and should keep the entire icemaker shut off at least 20 minutes in high ambient temperatures, longer in low ambient temperature during normal operation. Settings are 35-degrees F. CUT-OUT and 45-degrees F. CUT-IN.*

21. Check the elbow and switch assembly.

## NOTE

*The elbow and switch assembly is manually reset and functions as a safety switch, to automatically stop the icemaking process if the bin thermostat control were to fail and cause ice to jam up in the ice transport tube.*

## CLEANING — Icemaker

1. PRESS the master ON-OFF pushbutton to OFF.
2. Remove screws, top and the front panel.
3. Remove all ice from the ice storage bin.
4. Remove the reservoir cover and block the float in the water reservoir up to stop water flow.
5. Disconnect the tube between the water reservoir and the bottom of the freezer assembly and drain water from the reservoir and tube. Reconnect the tube.

## WARNING

**SCOTSMAN Ice Machine Cleaner contains Phosphoric and Hydroxyacetic acids. These compounds are corrosive and may cause burns. If swallowed, DO NOT induce vomiting. Give large amounts of water or milk. Call Physician immediately. In case of external contact flush with water. KEEP OUT OF THE REACH OF CHILDREN.**

6. Prepare cleaning solution: Mix six ounces of SCOTSMAN Ice Machine Cleaner with one and one-half quarts of hot water.
7. Slowly pour the cleaning solution into the water reservoir.
8. PRESS the master ON-OFF pushbutton to ON.
9. Continue to slowly pour the cleaning solution into the water reservoir, maintain level just below the reservoir overflow.
10. Continue icemaking, using the cleaning solution, until all the solution is used up and the water reservoir is almost empty. DO NOT allow the icemaker to operate with empty reservoir.
11. PRESS the master ON-OFF pushbutton to OFF.
12. Wash and rinse the water reservoir.
13. Remove the block from the float in the water reservoir.
14. PRESS the master ON-OFF pushbutton to ON.
15. Continue icemaking for at least 15 minutes, to flush out any cleaning solution. Check ice for acid taste - continue icemaking until ice tastes sweet.
16. PRESS the master ON-OFF pushbutton to OFF.

## CAUTION

**DO NOT use ice produced from the cleaning solution. Be sure none remains in the bin.**

17. Remove all ice from the ice storage bin.
18. Add warm water to the ice storage bin and thoroughly wash and rinse all surfaces within the bin.
19. Clean and sanitize the ice storage bin each week.