

# MF6B

## TABLE OF CONTENTS

<b>GENERAL INFORMATION &amp; INSTALLATION</b>	
Introduction .....	4
Description .....	4
Sealed Refrigeration System .....	4
Storage Bins .....	4
Unpacking and Inspection Control .....	4
Location and Leveling .....	5
Electrical Connections .....	5
Water Supply and Drain Connections .....	5
Final Check List .....	6
<b>OPERATING INSTRUCTIONS</b>	
Start-Up .....	8
Icemaker Operation .....	10
Electrical/Refrigeration .....	10
<b>ADJUSTMENT, REMOVAL &amp; REPLACEMENT</b>	
Bin Thermostat Control .....	12
Crankcase Heater .....	37
Compressor Assembly .....	37
Condenser — Air-Cooled Models .....	37
Condenser — Water-Cooled Models .....	37
Water Regulator Assembly .....	38
Water Reservoir Float .....	38
Auger, Water Seal, Bearings and Coupling .....	38
Drier .....	39
Drivemotor Assembly .....	39
Fan Motor Assembly — Air-Cooled Models .....	39
Freezer Assembly .....	39
Low Water Pressure Control .....	40
Water Regulator Assembly — Water-Cooled Models .....	40
Water Reservoir Assembly .....	40
<b>SERVICE DIAGNOSIS</b> .....	41
<b>MAINTENANCE AND CLEANING INSTRUCTIONS</b>	
General .....	44
Icemaker .....	44
Cleaning — Icemaker .....	45

## LIST OF ILLUSTRATIONS

Specifications .....	2
Component Location .....	3
Installation Practice .....	7
Water Schematic .....	8
Refrigeration Cycle .....	10
Adjustment of the Temperature Control .....	12
<b>PARTS LIST &amp; WIRING DIAGRAMS</b> (Printed in Yellow) .....	13
<b>PARTS LIST:</b>	
Cabinet Assembly .....	14
Major Assembly .....	16
Air-Cooled Assemblies .....	18
Water-Cooled Assemblies .....	19
Spout Assembly .....	20
Reservoir Assembly .....	20
Drive Motor Assembly .....	21
Freezer Assembly .....	21
Gear Reducer .....	22
Control Box (Air-Cooled) .....	23
Control Box (Water-Cooled) .....	24
<b>WIRING DIAGRAMS:</b>	
Air-Cooled Models - 230/60/1 .....	25
Water-Cooled Models - 230/60/1 .....	26
Air-Cooled Models - 208/60/1 & 208-220/60/3 .....	27
Water-Cooled Models - 208/60/1 & 208-220/60/3 .....	28
Air-Cooled Models - 230/60/1 .....	29
Water-Cooled Models - 230/60/1 .....	30

**THIS PAGE  
INTENTIONALLY  
LEFT BLANK**

# MF6B SPECIFICATIONS

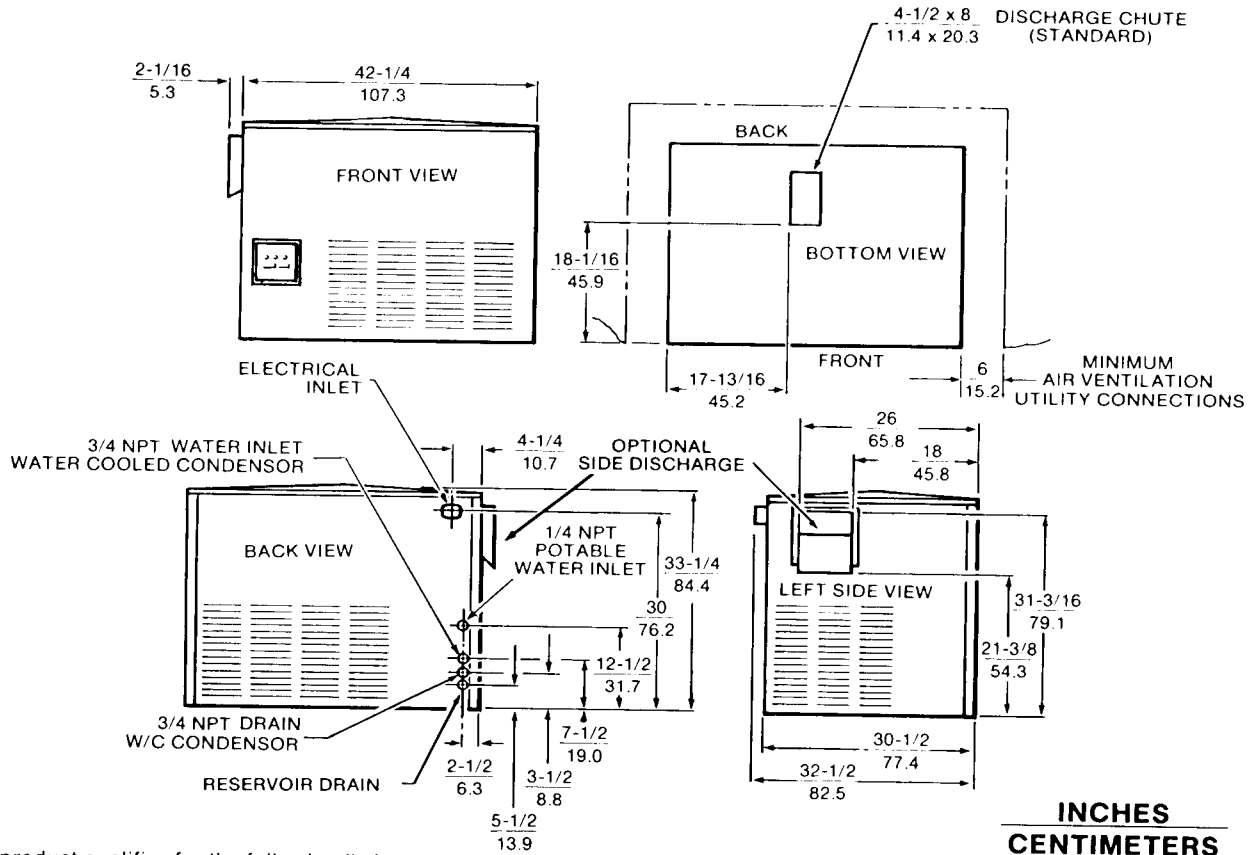

This product qualifies for the following listings:



## FLAKERS WITH ICE STORAGE BINS

Model Number	(Height - w/o Legs) Dimensions H" x W" x D"	Cond. Unit	Finish **	Basic Electrical	Comp. H.P.	Heater Watts	Max. Oper. Amps.	No. of Wires	Min. Circuit Ampacity †	Max. Fuse Size	Ship. Wt. lbs./kg.
<b>MF6B VOLUME FLAKER</b>											
MF6AE-2B	33 1/4 x 42 1/4 x 32 1/2	Air	EC	230/60/1	2	65	15.2	2	16.0	20	630/286
MF6AE-3B	33 1/4 x 42 1/4 x 32 1/2	Air	EC	208-220/60/3	2	65	13.7	3	14.3	20	630/286
MF6AE-7B	33 1/4 x 42 1/4 x 32 1/2	Air	EC	208/60/1	2	65	15.4	2	16.3	20	630/286
MF6WE-2B	33 1/4 x 42 1/4 x 32 1/2	Water	EC	230/60/1	2	65	13.8	2	14.7	20	608/276
MF6WE-3B	33 1/4 x 42 1/4 x 32 1/2	Water	EC	208-220/60/3	2	65	11.9	2	12.6	20	608/276
MF6WE-7B	33 1/4 x 42 1/4 x 32 1/2	Water	EC	208/60/1	2	65	14.0	2	15.0	20	608/276

Order **SPKMF6** panel kit for stainless steel finish. MF6 will stack on top of the B80, B90 or B120 bins and extensions for ice storage. **KSE6** - Optional discharge kit. Electrical, water inlets and drains located in lower right of back panel. Ice discharge chutes are located on bottom or left side panel (Back view).

### IMPORTANT OPERATING REQUIREMENTS

	MINIMUM	MAXIMUM
Air Temperatures .....	50° F (10.0° C)	100° F (37.7° C)
Water Temperatures .....	40° F (4.4° C)	100° F (37.7° C)
Water Pressures .....	20 lbs. gauge	120 lbs. gauge
Electrical Voltage Variation		
Voltage rating specified		
on nameplate .....	-10%	+10%

Extended periods of operation exceeding these limitations constitutes misuse under the terms of Scotsman Manufacturer's Limited Warranty, resulting in a loss of warranty coverage.

We reserve the right to make product improvements at any time. Specifications and design are subject to change without notice.

# MF6B GENERAL INFORMATION AND INSTALLATION

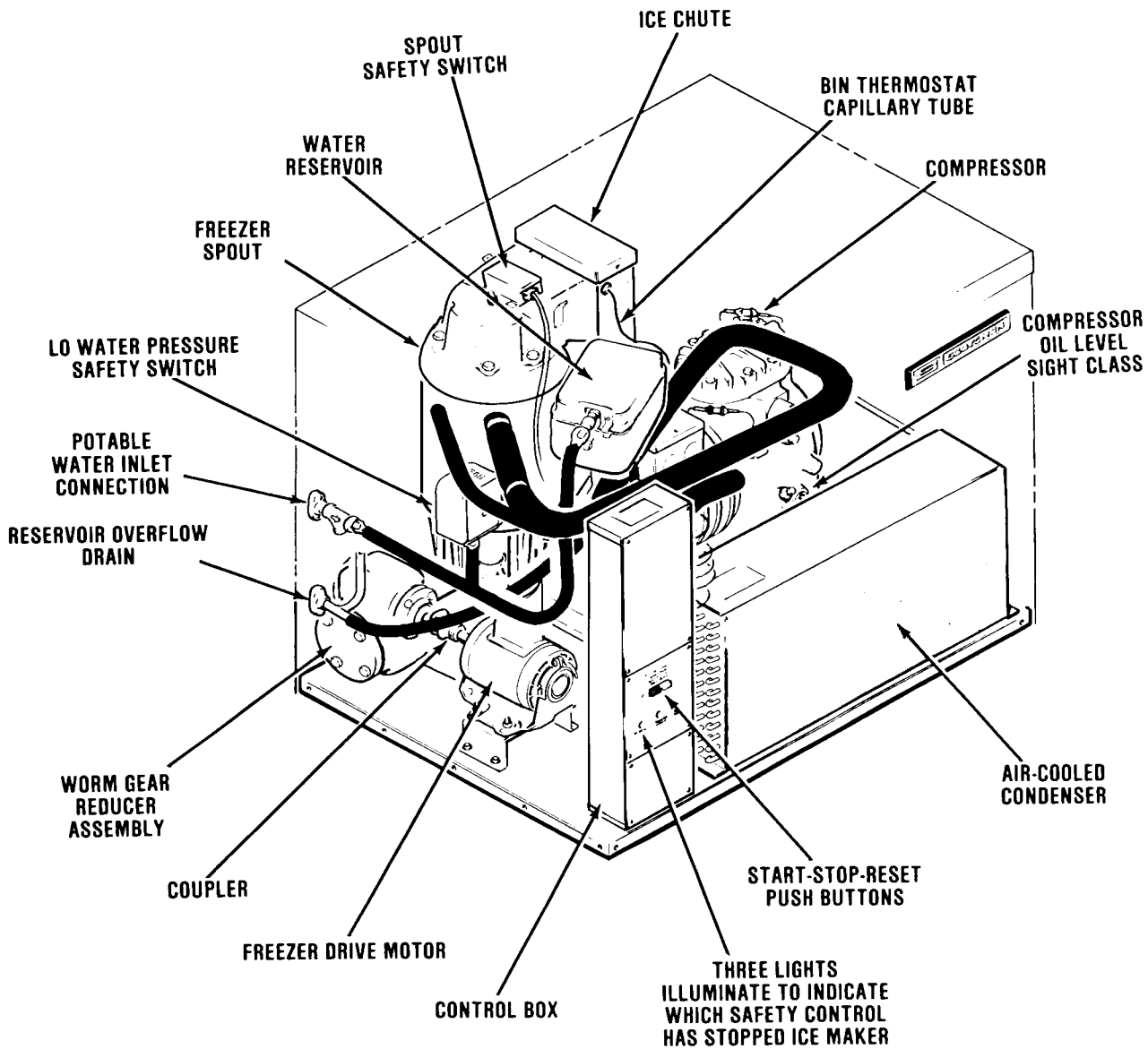

*Major Component Location*

# GENERAL INFORMATION AND INSTALLATION

## INTRODUCTION

This manual provides the specifications and the step-by-step procedures for the installation, start-up and operation, and the maintenance and cleaning for the SCOTSMAN Model MF6B Modular Flakers.

The Model MF6B Modular Flakers are quality designed, engineered and constructed, and thoroughly tested ice-making systems, providing the utmost in flexibility to fit the needs of a particular user. Separate sections detail more specifically: General Information & Installation; Start Up Operation; Principles of Operation; Maintenance and Cleaning Instructions.

## DESCRIPTION

An attractive compact cabinet of leathergrain embossed steel, with charcoal brown baked enamel high gloss finish. Also, an optional stainless steel panel kit is available. These removable panels allow easy access to electrical and mechanical components for cleaning and maintenance.

Three built-in safety controls protect the machine from damage due to water shortage, abnormal refrigerant operating pressures, or drive motor overload. Three separate lights indicate which safety control has shut the machine off.

## SEALED REFRIGERATION SYSTEM

To provide quiet efficient operation of the Icemaker, the Compressor motor is externally spring-mounted. The Compressor motor is covered by a five year parts warranty. The Freezer Assembly is powered by a worm gear reducer and Drivemotor Assembly.

## STORAGE BINS

Since the MF6B Modular Flakers are continuous flow type icemakers and do not have their own attached ice storage bins, it is necessary to use an auxiliary bin, such as the bins listed below:

Use Bins: B80, B90, B750.

Accessories: BX83, BX87.

Custom built storage bins:

Bins should have a minimum of one-half of the icemaker's perday icemaking storage capacity and it should also provide adequate support for the icemaker and its contents.

## UNPACKING AND INSPECTION CONTROL

1. Call your authorized SCOTSMAN Distributor or Dealer, for proper installation. He's listed under ICEMAKING EQUIPMENT and MACHINERY in the yellow pages of the telephone book.
2. Visually inspect the exterior of the shipping container and skid. Any severe damage should be reported to the delivering carrier; and a concealed damage claim filed, subject to internal inspection, with the carrier representative present.
3. BEFORE removal of any panels or packing, carefully raise cabinet up and remove the shipping bolts and the shipping base or skid.
4. Remove screws and shipping tape and all doors and service panels from the cabinet, inspect for any concealed damage. Notify carrier of any concealed damage claims, as stated in Step 2 above.
5. Remove all internal support packing, tape and wires in machinery compartment.
6. Check that refrigerant lines do not rub or touch lines or other surfaces and that fan blades, if any, move freely.
7. Remove compressor hold down straps to enable compressor to ride free on vibration cushioning mounts.
8. If local water supply conditions require, install a water purification system in icemaker water supply line.
9. Use clean damp cloth or disposable paper wiper to wipe clean the exterior surfaces of the cabinet.
10. See NAMEPLATE and check that the location source voltage corresponds with the voltage specified on the nameplate.

## CAUTION

**Improper voltage supplied to the Icemaker will void your parts replacement program.**

11. Packaged on the cabinet top panel is the Manufacturer's Registration Card. Fill in all spaces including the Model Number and Serial Number. With cabinet panel removed, locate data found on the aluminum plate, on the upper right side of Control Box. Forward the completed, self-addressed registration card to the SCOTSMAN Factory.

# MF6B GENERAL INFORMATION AND INSTALLATION

## LOCATION AND LEVELING

### WARNING

This Modular Flaker is **NOT** designed for outdoor installations, or where air temperatures are below 50-degrees F., or above 100-degrees F., and the water temperature is below 40-degrees F. or above 100-degrees F. Extended periods of operation at temperatures exceeding these limitations will constitute misuse, under the terms of the SCOTSMAN Manufacturer's limited warranty coverage.

### NOTE

*Prior consideration for location site shall include:*

*Minimum room temperature 50-degrees F. and Maximum room temperature 100-degrees F.*

*Water inlet temperatures: Minimum 40-degrees F. and Maximum 100-degrees F.*

*Well ventilated location for air-cooled model, advising user to frequently clean condenser, located directly behind the front panel.*

*SERVICE ACCESS: Adequate space for all service connections, through the rear of the Cabinet. A six-inch minimum clearance at rear, left and front lowered panels, for routing cooling air drawn into and exhausted out of the compartment, to maintain proper condensing operation on air-cooled models.*

1. All standard MF6B models are equipped with bottom center discharge chute installed. This permits top mounting on modular companion Scotsman ice storage bins, or bin extensions.
2. Position the flaker in the selected permanent location.
3. Level the Cabinet in both the left-to-right and front-to-rear directions.
4. Loosen motor compressor hold down nuts to permit motor compressor to ride free on mounting pads.

### ELECTRICAL CONNECTIONS

SEE NAMEPLATE for current requirements to determine wire size to be used for electrical hookup. The Modular Flaker requires a solid earth ground wire. Make sure nameplate voltage and building source voltage correspond. See wiring diagram.

Be certain the Modular Flaker is connected to its own electrical circuit and individually fused. The maximum allowable voltage variation should not exceed ten percent of the nameplate rating, even under starting conditions. Low voltages can cause erratic operation and may be responsible for serious damage to the overload switch and motor windings.

Failures of this type are not considered a factory defect.

**All external wiring should conform to the National, State and local electrical code requirements. Usually an electrical permit and services of a licensed electrician will be required.**

### WATER SUPPLY AND DRAIN CONNECTIONS

**POTABLE WATER:** The recommended potable water supply line should be a minimum 1/2-inch O.D. tubing for short runs and a minimum 5/8-inch O.D. tubing for long runs and connects to a 1/4-inch NPT female pipe casting on the icemaker. Connect to cold water supply line with standard plumbing fittings with a shutoff valve installed in an accessible place between the water supply and the cabinet.

A reservoir strainer is installed within the icemaker cabinet in the water supply line. The strainer protects the icemaker from large particles of rust, scale, etc., which may be loosened in the water supply pipe.

In some cases, a plumbing permit and services of a licensed plumber will be required.

### WARNING

**To prevent damage to the freezer mechanism, DO NOT operate this unit when the water supply is OFF, or is below 20 PSI, the recommended water pressure. Position the master switch to the OFF position, until proper water supply is resumed.**

The Icemaker in this Cabinet will not operate when water supply temperatures are below 40-degrees F. or above 100-degrees F.

**CONDENSER WATER (WATER-COOLED ONLY):** On water-cooled models a separate connection to the condenser is required. A 3/4-inch female pipe casting is provided to connect the water line to the machine. Observe arrow on water regulating valve. Incoming water goes through the water regulating valve and into the water cooled condenser.

### NOTE

*If cooling tower is used to cool water cooled models, several precautions should be observed.*

1. *Consult your tower and pump manufacturer for proper installation specifications and procedures.*
2. *Only potable city water should be used for icemaking.*
3. *Water regulating valve should not be removed from the icemaker.*
4. *Use 3/4-inch nominal size interconnecting*

# MF6B

## GENERAL INFORMATION AND INSTALLATION

tubing or larger depending on the length of run. If over 30 ft. use 1-inch nominal size inter-connecting tubing.

### WARNING

**If icemaker is used year around, cooling tower efficiency directly effects the ice making capacity. A combination of cooling methods may be used; City water cooling in winter months and cooling tower in summer months.**

### NOTE

*In both air-cooled and water-cooled installations, water supply must be installed to conform with local plumbing codes. In some cases, a plumbing permit and services of a licensed plumber will be required.*

**DRAIN CONNECTIONS:** All drains are gravity type and must have 1/4-inch per foot fall on horizontal runs. The recommended water cooled condenser drain is a nominal 3/4-inch O.D. tubing. All drains to be installed to conform with local code. The drain receptacle should be an open, trapped or vented construction.

### WARNING

**This Modular Flaker will NOT operate when water supply temperature is below 40-degrees F., or above 100-degrees F. Requires 20 PSI flowing water pressure, without interruption.**

### FINAL CHECK LIST

1. Has the electrical power to icemaker been connected to start the 12-hour period of PRESTART crankcase heating?
2. Is the Cabinet level? (IMPORTANT)
3. Have all electrical and piping connections been made?
4. Has the voltage been tested and checked against the nameplate rating?
5. Is the water supply line shutoff valve installed and electrical wiring properly connected?
6. Is water reservoir filled and shut off? All packing removed?
7. Have the Bin and Cabinet been wiped clean?
8. Loosen motor compressor hold down nuts to permit motor compressor to ride free on mounting pads.
9. Has the owner/user been given the User Manual and instructed on how to operate the Icemaker?
10. Has the Manufacturer's Registration Card been properly filled out? Check for correct Model and Serial numbers from Serial nameplate, then mail the completed card to the SCOTSMAN factory.
11. Check all refrigerant and conduit lines to guard against vibration or rubbing and possible failure.
12. Is there at least six inches clearance behind and around Cabinet for proper air circulation?
13. Is the Cabinet in a room where ambient temperatures are a minimum of 50-degrees F. all year around?
14. Has water supply pressure been checked to insure a minimum of 20 PSI?
15. Has the owner been given the name and telephone number of the authorized SCOTSMAN Service Agency serving him?

**MF6B**  
**GENERAL INFORMATION AND INSTALLATION**

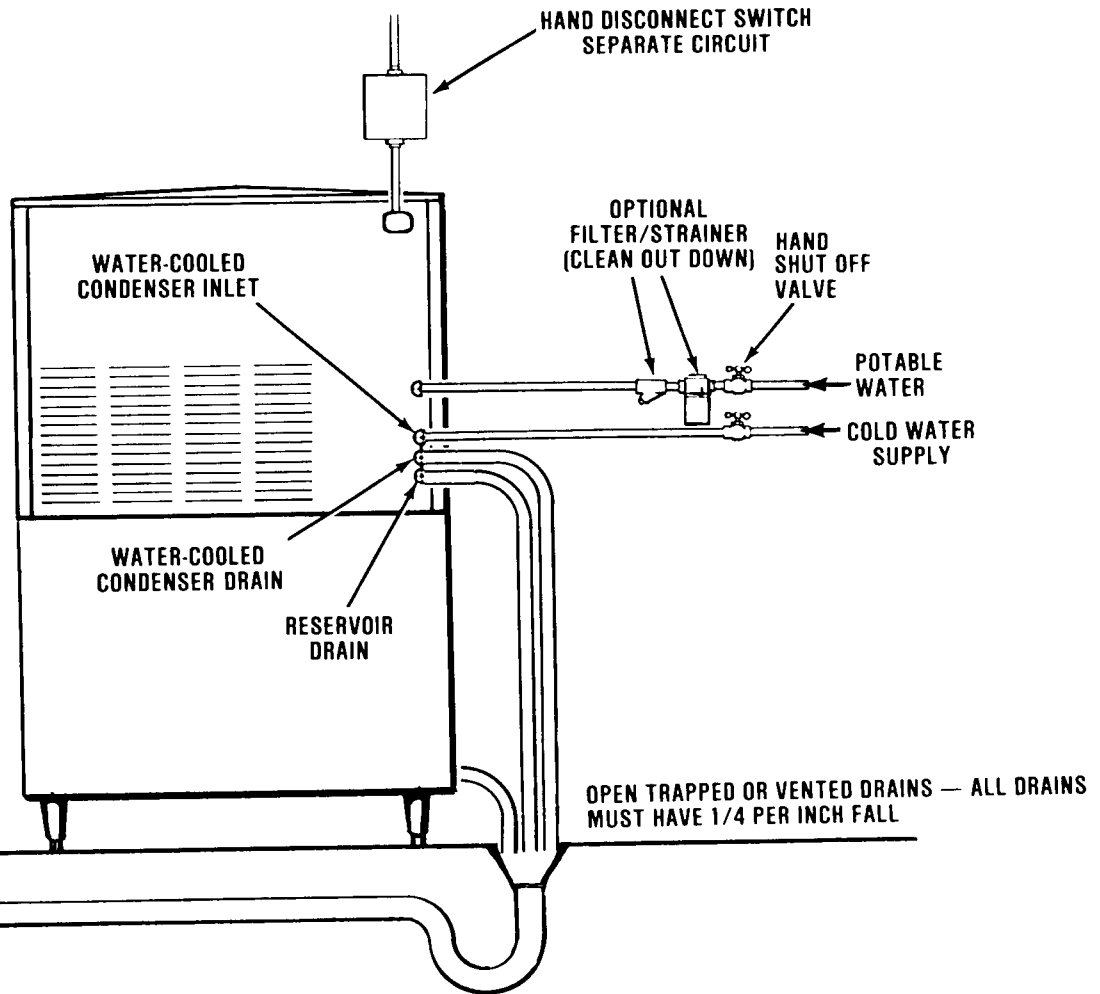



# MF6B OPERATING INSTRUCTIONS

## START UP

1. Connect electrical power to icemaker 12 hours prior to following Start-Up steps.
2. Remove screws and cabinet top and front panels.
3. OPEN the water supply valve.
4. Observe the water filling operation.
  - a. Water flows into Water Reservoir.
  - b. Float moves up as water rises.
  - c. Water flows through water feed line to bottom of Freezer Assembly.
  - d. Check water reservoir level. Keep water level below water overflow, but as high as possible, do not permit water level to become so high that water runs out spout opening with machine OFF. It is normal for some water droplets to be expelled during machine operation along with ice flow.
5. Press the START/RESET push button located on the control panel front to start the automatic and continuous icemaking process.
6. After two or three minutes of operation, observe that flaked ice begins dropping out the Ice Chute and into the Ice Storage Bin.
7. Let the system operate for about 30 minutes or until ice covers the bottom of the Bin. Check for any excess noise beyond normal Compressor noise:
  - a. Fan noises, when Air-Cooled: Blades touch other surfaces; blades bent, out-of-balance.
  - b. Vibrating type, from touching lines.
  - c. Chattering: Lack of water in Freezer.
  - d. Observe that compressor rides free and compressor hold-down bolts have been loosened.

## WARNING

**DO NOT** operate this icemaker when the water supply is shut OFF, or is **BELOW** the recommended 20 PSI water pressure. Press the OFF push button switch on the front of the Control Box to the OFF position immediately.

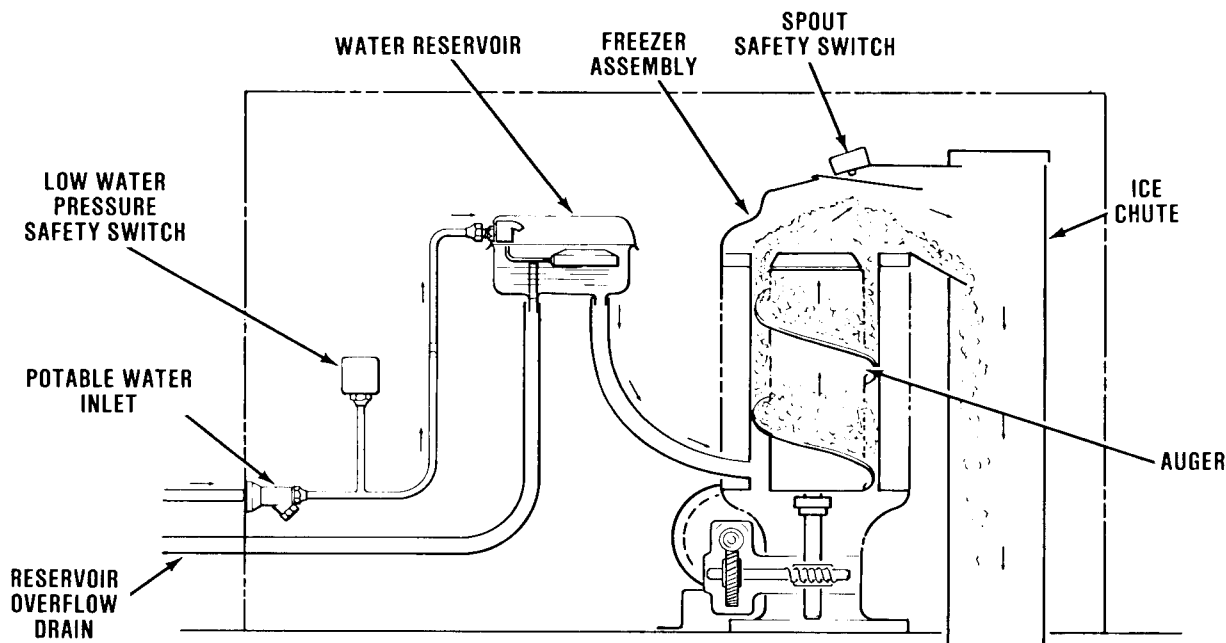

Water Schematic

## MF6B OPERATING INSTRUCTIONS

8. Check pressure settings at the time of start-up. On the Water-Cooled models set the head pressure at 135 PSI. On the Air-Cooled models the head pressure will vary between 130 and 145 PSI. The frost line should extend out of the accumulator if properly charged with refrigerant. The suction pressure will range between 12 and 14 PSI with 50° F. inlet water. Check the hand reset low pressure control setting. This safety device should be set at approximately 5 PSI below normal operating suction pressure and should cut off in case of interruption in water supply, shortage of refrigerant, low ambient or any other cause of abnormally low suction pressure.
9. Hold a handful of ice around the Ice Storage Bin Thermostatic Control Bulb to test shutoff. Less than one minute is about normal for Bulb shutoff function to cause the Compressor to stop.

### NOTE

*Within minutes after the ice is removed from the sensing bulb, the bulb will warm up and cause the Icemaker to restart. This control is factory set and should not be reset until testing is performed. Normal setting: about 35-degrees F. CUT-OUT and 45-degrees F. CUT-IN, to prevent short cycling.*

10. Thoroughly explain to the owner/user the significant specifications of the Icemaker, the start up and operation, going through the procedures in the operating instructions. Answer all questions about the Icemaker, by the owner; and, inform the owner of the name and telephone number of the authorized SCOTSMAN Service Agency serving him.

# MF6B OPERATING INSTRUCTIONS

## ICEMAKER

The water supply flows from the building source and enters the rear of the icemaker at the Cabinet fitting, and on through the reservoir strainer to the Water Reservoir.

A stainless steel Auger within the Freezer is rotated by the Drivemotor Assembly through a worm gear reducer.

The rotating auger carries the ice upward to the ice breaker at the top of the cylinder by means of a stainless steel auger and is discharged into the ice chute and falls into the ice storage bin.

Pressing the manual START-RESET push button, on the front of the Control Box, to the ON position starts the automatic and continuous icemaking process. With the Ice Storage Bin has been filled with ice, up to the level of the Thermostatic Control Bulb, the sensing bulb shuts off the icemaking process.

As the ice is removed from the Ice Storage Bin, the Thermostatic Control Bulb warms up, restarting the automatic icemaking process.

Factory settings are 35-degrees F. CUT-OUT and 45-degrees CUT-IN.

## ELECTRICAL/REFRIGERATION

Compressor Crankcase Heater — The crankcase heater is an electrical 65 watt heater located on the bottom of the Compressor, electrically connected across main power line. Heater is ON whenever current is supplied to the icemaker, supplying enough heat to keep liquid refrigerant from migrating and settling in Compressor crankcase.

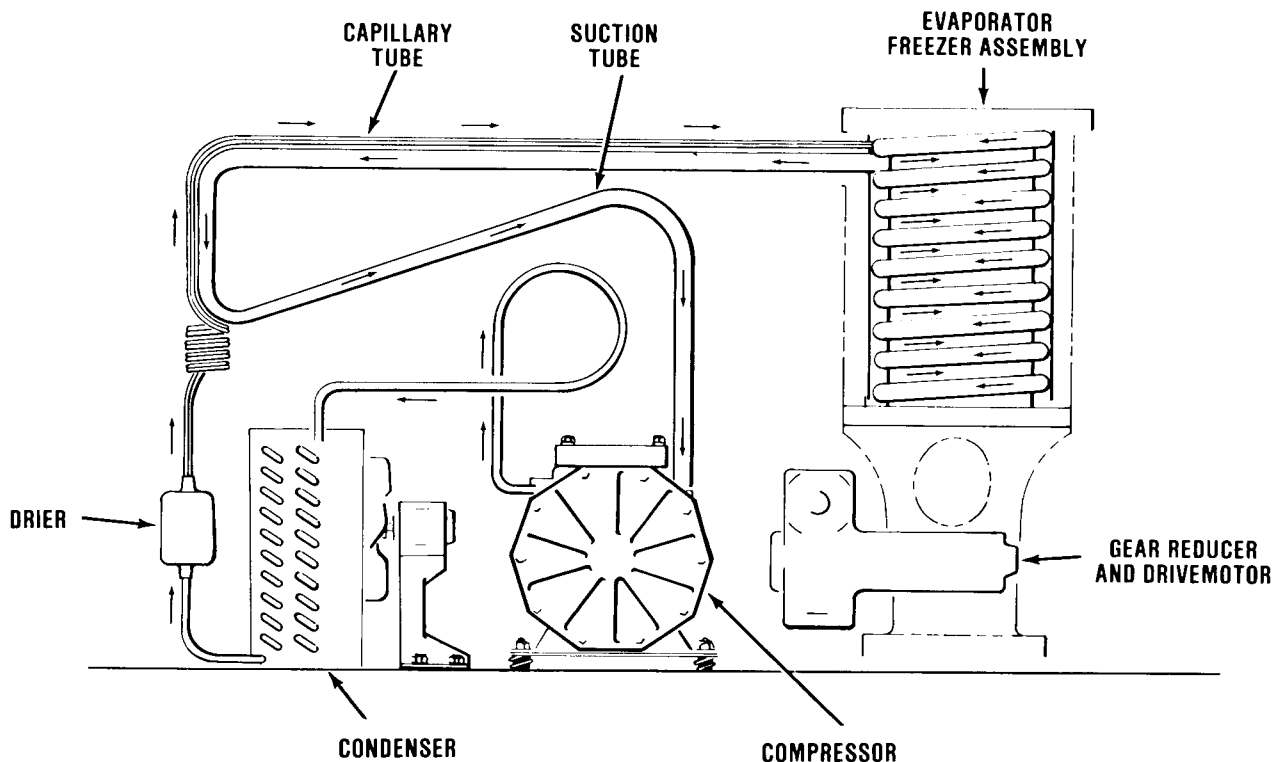

*Refrigeration Cycle*

# MF6B OPERATING INSTRUCTIONS

The MF6B Modular Flakers are designed to operate on 230 volts, 60 Hertz, 1 phase. Special voltage requirements are available on special order. Therefore, always CHECK NAMEPLATE for circuit voltage to determine correct connecting wire sizes to the icemaker.

Cold ambient temperatures and interruptions in water supply are conditions that can cause excessively hard ice and overloads within the Freezer Assembly, which is directly transmitted to the worm gear reducer and Drivemotor assembly, and in turn, will cause speed reduction or ultimate freezeup.

A Spout Switch is mounted on the top of the Ice Spout and is actuated by the movement of ice build-up pressing on the actuator plate. The Spout Switch acts as a backup safety switch, should the Thermostatic Control Bulb fail and cause ice to jam up in the Ice Chute. The switch will shut off the compressor only when actuated.

There are three safety controls in the Control Box on the Water-Cooled models and two safety controls on the Control Box for the Air-Cooled Models. The Low Pressure Control, a manual reset, non-adjustable control is used on both air and water-cooled models and is set to electrically open at zero to four PSIG to stop the entire icemaker. The Auger Delay Switch, a single-pole double-throw (SPDT) switch, functions as a control device to allow the Drivemotor gear reducer to rotate the Auger to clear the Freezing Chamber while the compressor circuit is OFF.

Refer to the appropriate Wiring Diagram and trace circuitry and control functions, as described in the following paragraph.

As shown on all SCOTSMAN wiring diagrams, the controls are in the ICEMAKING MODE. Thus, the 1-2 contacts are CLOSED. At START-UP, the 1-2 contacts are OPEN and the 3-2 contacts are CLOSED. As the icemaker begins to operate, the low side pressure starts to decrease from the stabilized or at-rest pressure. As soon as the pressure is reduced to 20 PSIG, the 3-2 contacts OPEN and the 1-2 contacts CLOSE.

This removes the operating controls, such as the Bin Thermostat, from the gearmotor circuit. If one of the operating controls OPENS, it will SHUT OFF the compressor circuit. The gearmotor will operate until the low side pressure increases to 32 PSIG. Then, the 1-2 contacts OPEN and SHUT OFF the drive-motor, usually within one to two minutes, depending upon ambient conditions. This brief period of

time allows the Auger to remove the ice from the freezing chamber. Consequently, when called on to STARTUP again, there is no ice load to start up against. Again, on STARTUP, the 1-2 contacts are OPEN and the 3-2 contacts are CLOSED.

On all models, a low-water pressure switch functions to discontinue the Icemaking process whenever incoming water pressure is reduced to below five PSIG. The Switch will automatically restart the Icemaking process when the water pressure is increased to 20 PSIG.

On the Water-Cooled models only, a manual reset, high head pressure control is factory set to stop the entire icemaker should the head pressure reach 250 PSIG.

On Water-Cooled models, correct head pressure is 135 PSIG. Adjustments can be made on the Water Regulator Assembly valve. On Air-Cooled models, the head pressure is normal about 130 PSIG, however, it will vary depending upon ambient air temperature.

Air-Cooled models: Two separate Fan assemblies maintain head pressure between limits set on the Controls. Certain low ambient conditions will cause low head pressure, which will open a Control, in turn stopping the Fan motor. This reduction in air flow will cause head pressure to build up and Fan motor to restart.

The right Fan assembly is high pressure controlled, with a SPST non-adjustable, automatic reset. It is mechanically connected to system Hi side. This control cycle is ON at 170 PSIG, OFF at 154 PSIG.

The left Fan assembly is a Lo pressure control, SPST non-adjustable, automatic reset. It is mechanically connected to system Lo side. This control cycle is ON at 155 PSIG, OFF at 139 PSIG.

Suction pressure should be 15 PSIG with proper refrigerant charge and the frost line should extend out from the accumulator about eight inches. Suction pressure will vary about two PSIG plus or minus, depending upon ambient temperatures and incoming water supply temperatures to the Freezer Assembly. When charging the system with refrigerant, on Water-Cooled Models, set the compressor head pressure at 135 PSIG and charge with refrigerant so the frost line extends out of the Compressor at least eight inches after 15 minutes of operation for best capacity and performance.

Always check name plate for proper charges of R-12.

# ADJUSTMENT AND REMOVAL AND REPLACEMENT PROCEDURES

The procedures provided in this Section are arranged in alphabetical order to make specific Adjustment and Removal and Replacement information easy to locate.

Read the instructions thoroughly before performing any Adjustment or Removal and Replacement Procedures.

## ADJUSTMENT OF THE BIN THERMOSTAT CONTROL

The control for the Bin Thermostat is the Temperature Control, located in the upper part of the Control Box Assembly.

See Figure 4-1 for location and direction of rotation, clockwise (CW) or counterclockwise (CCW), of the adjusting screws on the Temperature Control, in the particular Control Box the adjustment is to be performed.

## WARNING

The adjusting screws on the Temperature Control device have very sensitive response to adjustment. **DO NOT** attempt to adjust the screw until after thoroughly reading and understanding the following instructions and illustrations. Over-adjusting or erratic guessing can foul the instrument and cause ultimate delay and part replacement, WHICH COULD HAVE BEEN PREVENTED.

### GENERAL ELECTRIC

ADJUST  
RANGE SCREW

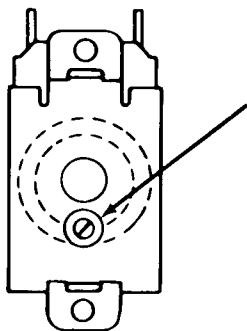

ROTATE CCW



### ROBERTSHAW

ADJUST RANGE SCREW

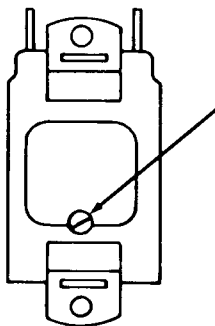

ROTATE CW



### RANCO

ADJUST  
RANGE SCREW  
(BEHIND PANEL, TOP SIDE)

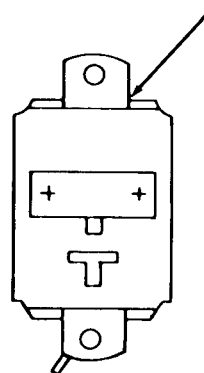

ROTATE CW



# THE PARTS ILLUSTRATIONS AND PARTS LISTS

## GENERAL

This section contains the Parts Illustrations and the Parts List for each of the major assemblies in the Model MF6.

A No. Number designation, when used in the Part Number Column indicates the unit is not available from SCOTSMAN as an assembly. This designation is used only for the convenience and clarity of division in cataloging.

## HOW TO ORDER PARTS/ASSEMBLIES

When ordering parts or assemblies, to avoid costly delays and errors in shipment, give the part number, the complete description shown in the list, and the quantities of each part or assembly required. Also, include the Model name, the serial number of the Modular Flaker for which the part is required, and for parts which require color matching the color of the Cabinet.

## IMPORTANT

- A. All Part Numbers have TEN DIGITS (spaces), required for use in the Computer System. BE SURE to fill in ALL SPACES in the CATALOG NUMBER column, on the Parts Order Form.
- B. Enter the QUANTITY of the Parts ordered, in the

last digit column under the QUANTITY column heading, the one under the small 55 number, for parts from 1 thru 9. For 10 or more parts use two columns.

To be sure you receive the proper parts in the proper quantities, ALWAYS use the PART NUMBERS and DESCRIPTIONS given in the Parts Manual.

Write an order for the Part. (Use SCOTSMAN Parts Order Form DN103) Be sure to include:

- a. Distributor Name
- b. (Use for DROP-SHIP order ONLY.)
- c. Distributor Purchase Order Number.
- d. Carrier.
- e. How shipped (Truck, Rail, UPS, etc.)
- f. Date ordered
- g. Part Catalog Number, (use full TEN digits (spaces) listed in Parts Manual, including dashes between numbers.)
- h. Description - as listed in Parts Manual
- i. Quantity - number of parts ordered. (Use far right column.)

## MF6B

# WIRING DIAGRAMS

This Section is provided as an aid in understanding the electrical circuitry of the MF6 Modular Flaker.

The Wiring Diagrams in this section are:

Wiring Diagram Air-Cooled Model MF6-2B.

Wiring Diagram Water-Cooled Model MF6-2B.

Wiring Diagram Air-Cooled Model MF6-3B.

Wiring Diagram Water-Cooled Model MF6-3B.

Wiring Diagram Air-Cooled Model MF6-7B.

Wiring Diagram Water-Cooled Model MF6-7B.

**MF6B**  
**THE PARTS ILLUSTRATIONS AND PARTS LISTS**

# MF6B THE PARTS ILLUSTRATIONS AND PARTS LISTS

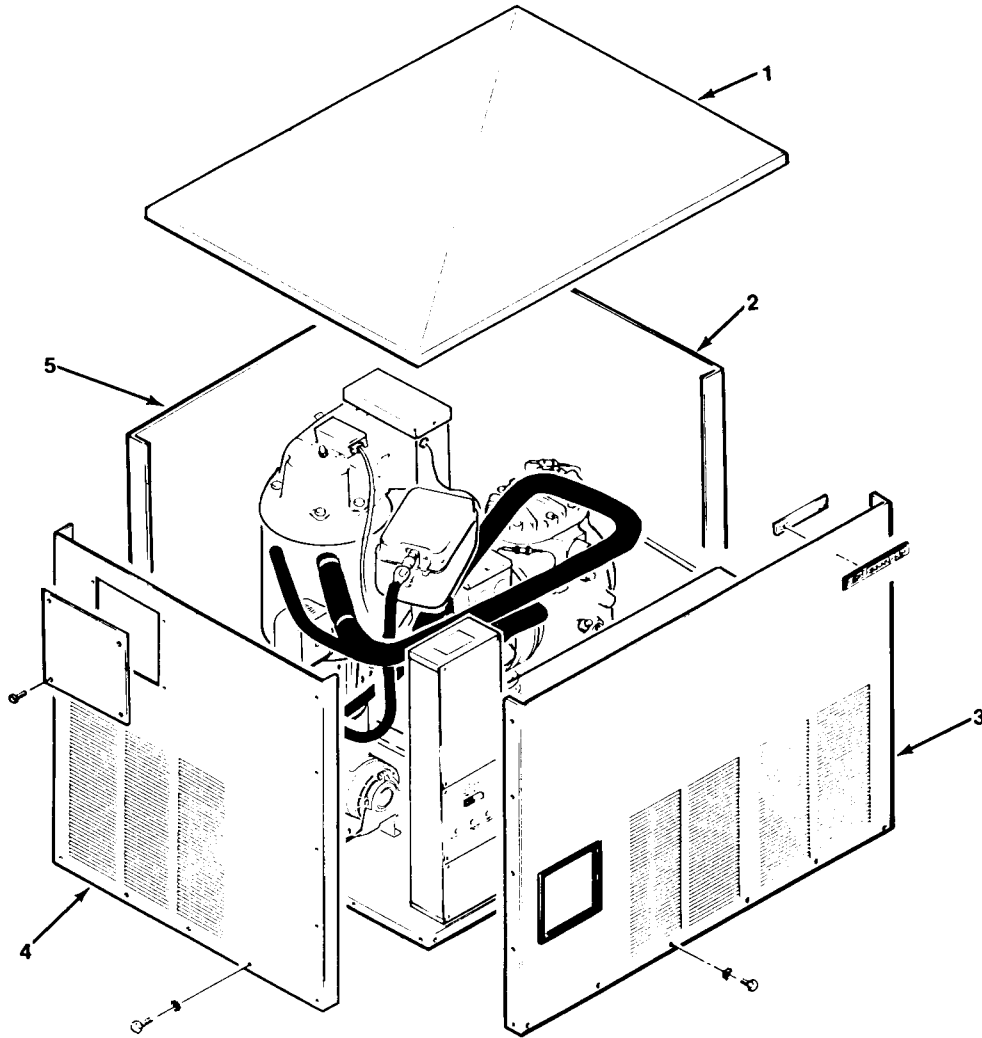

## CABINET ASSEMBLY

ITEM NUMBER	PART NUMBER	DESCRIPTION		PART NUMBER	DESCRIPTION	
1	A25883-004	TOP PANEL (ENAMEL)		A25879-004	LEFT SIDE PANEL (ENAMEL)	
	A25883-002	TOP PANEL (STAINLESS STEEL)		A25879-002	LEFT SIDE PANEL (STAINLESS STEEL) Attaching Parts Index 4	
2	A25881-004	RIGHT SIDE PANEL (ENAMEL)		A25919-004	COVER (ENAMEL)	
	A25881-002	RIGHT SIDE PANEL (STAINLESS STEEL)		A25919-002	COVER (STAINLESS STEEL)	
3	A25882-004	FRONT PANEL (ENAMEL)		5	A25885-004	BACK PANEL (ENAMEL)
	A25882-002	FRONT PANEL (STAINLESS STEEL) Attaching Parts Index 3			A25885-002	BACK PANEL (STAINLESS STEEL) Attaching Parts Index 1, 2, 3, 4, 5
	15-0156-00	EMBLEM		03-1417-09	LOCKWASHER, EXTERNAL TOOTH 1/4 INCH	
	03-1562-01	TUBULAR SPEED CLIP		03-0571-00	SCREW, THREAD CUTTING HEX HEAD 1/4-20 x 1/2-INCH	
	13-0801-01	TRIM MOLDING				



**MF6B**  
**THE PARTS ILLUSTRATIONS AND PARTS LISTS**

**MAJOR ASSEMBLIES**

<b>ITEM NUMBER</b>	<b>PART NUMBER</b>	<b>DESCRIPTION</b>
1	13-0595-00	GASKET ( 25" )
2	A25925-001	COVER
3	A25895-001	ICE CHUTE
4	<i>No Number</i>	RESERVOIR SUPPORT
		Attaching Parts Index 4
	03-0571-00	SCREW
	03-1417-09	LOCKWASHER
5	<i>No Number</i>	DRYER BRACE
		Attaching Parts Index 5
	03-1403-54	SCREW
	A20448-000	SLEEVE
6	02-0822-01	DRYER
7	<i>No Number</i>	CONTROL BOX BRACKET
		Attaching Parts Index 7
	03-0571-00	SCREW
	03-1417-09	LOCKWASHER
	03-1483-26	SCREW
8	A08893-000	MOTOR MOUNT
9	12-2226-32	DRIVEMOTOR
		Attaching Parts Index 9
	03-1406-08	NUT
	03-1407-05	WASHER
	A09239-000	SHIM
	03-1410-03	LOCKWASHER
	03-1417-09	LOCKWASHER
	A09239-001	SHIM
10	A18341-001	COUPLING ASSEMBLY
11	03-1405-34	SCREW
12	03-1417-16	LOCKWASHER
13	11-0296-00	WATER PRESSURE CONTROL
		Attaching Parts Index 3
	12-1213-10	BUSHING
14	A09056-000	RESERVOIR STRAINER
15	<i>No Number</i>	WATER IN-DRAIN CONNECTIONS
16	A09056-000	RUBBER SHIELD
17	A08895-00	COUPLING ASSEMBLY
		Attaching Parts Index 17
	02-1950-00	KEY
	03-0431-02	SET SCREW

# MF6B THE PARTS ILLUSTRATIONS AND PARTS LISTS

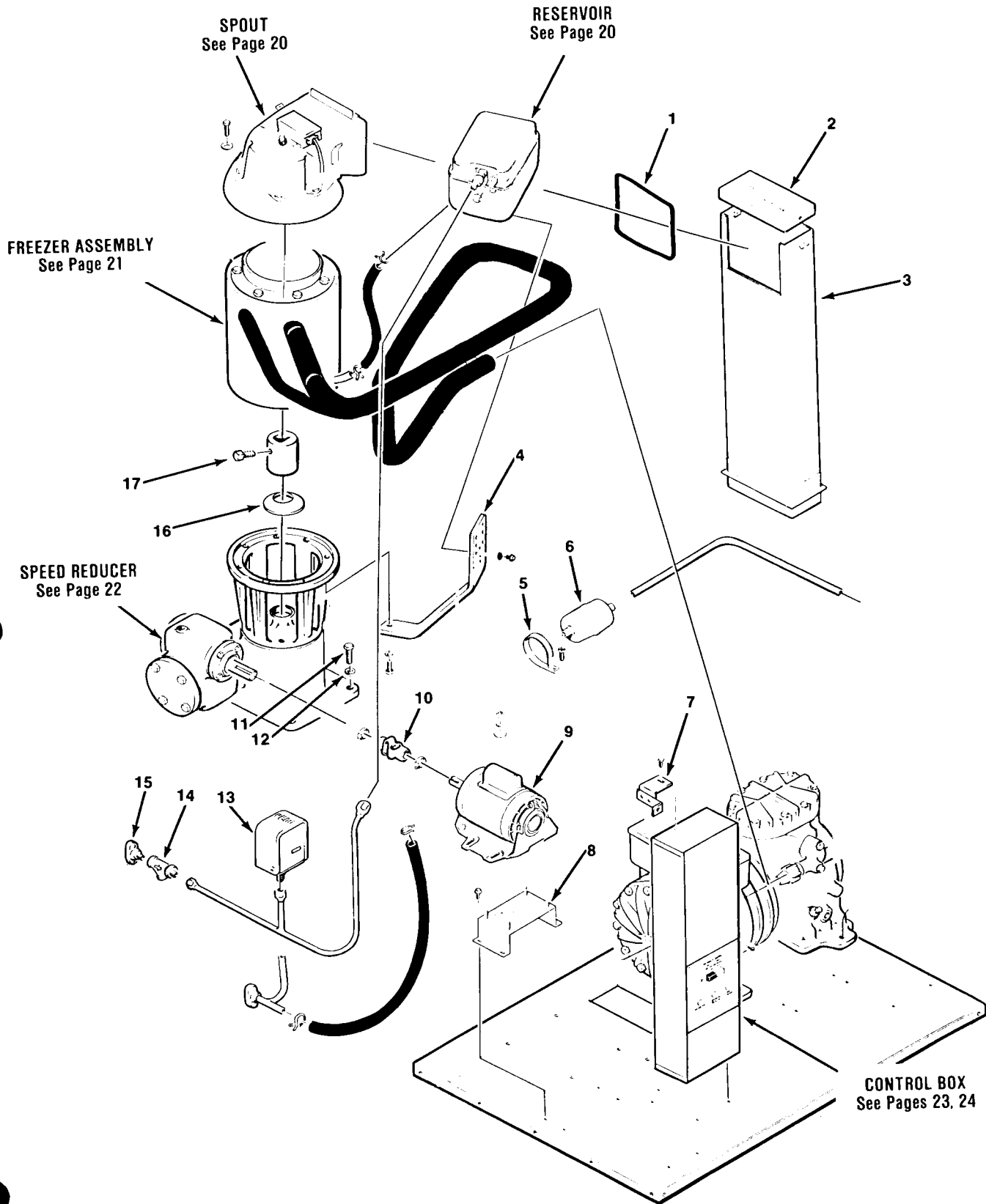

*Major Assemblies*

# MF6B THE PARTS ILLUSTRATIONS AND PARTS LISTS

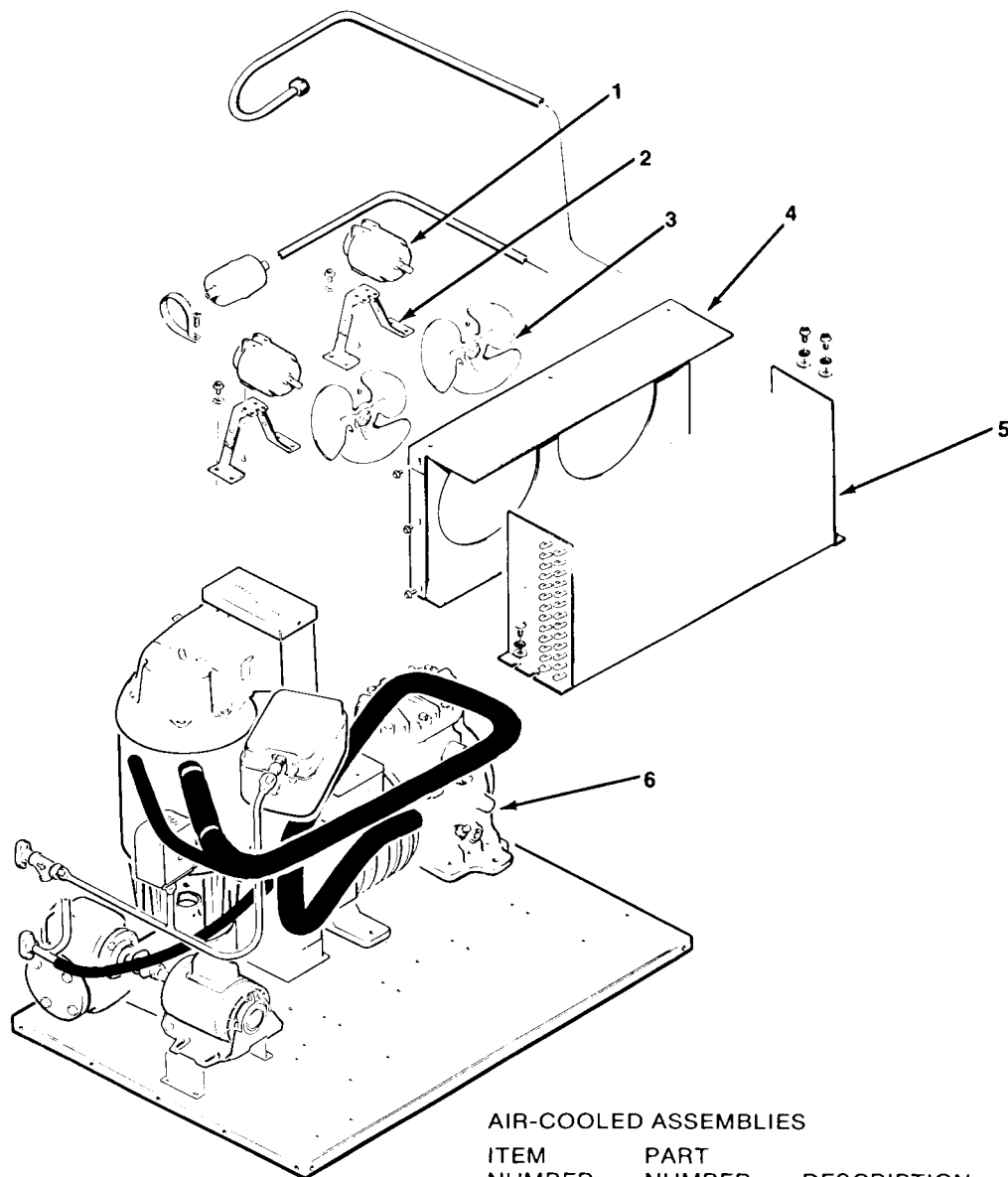

## AIR-COOLED ASSEMBLIES

ITEM NUMBER	PART NUMBER	DESCRIPTION	
1	18-0788-02	MOTOR, FAN 230/60/1	
	18-0788-07	MOTOR, FAN 208/60/1	
2	18-1421-00	MOUNT, MOTOR Attaching Parts Index 2	
	03-0571-00	SCREW	
	03-1410-03	LOCKWASHER	
3	18-0787-00	BLADE, FAN	
4	02-2564-01	SHROUD, CONDENSER Attaching Parts Index 4	
	03-1404-15	SCREW	
	18-0399-01	CONDENSER Attaching Parts Index 5	
5	03-0571-00	SCREW	
	03-1407-06	WASHER	
	03-1407-08	WASHER	
	6	18-0700-00	COMPRESSOR 230/60/1
		18-0711-00	COMPRESSOR 208/60/1
		18-0763-00	COMPRESSOR 208-220/60/3

# MF6B

## THE PARTS ILLUSTRATIONS AND PARTS LISTS

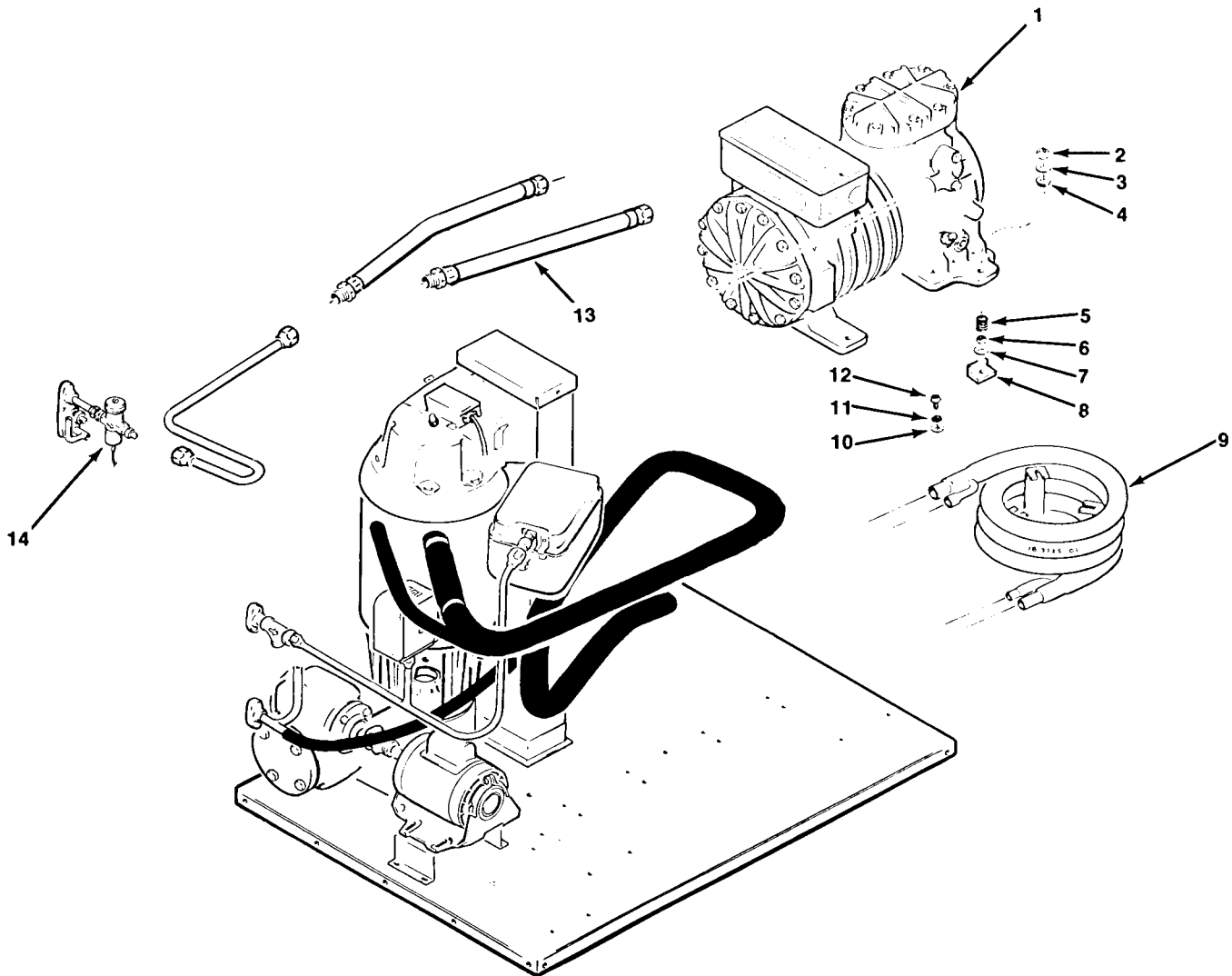

### WATER-COOLED ASSEMBLIES

ITEM NUMBER	PART NUMBER	DESCRIPTION
1	18-0702-00	COMPRESSOR, 230/60/1
	18-0704-00	COMPRESSOR, 208/60/1
	18-0718-00	COMPRESSOR, 208-220/60/3
2	18-1400-24	MOUNTING NUT
3	03-1407-10	WASHER
4	No Number	RUBBER SPACER
5	No Number	GRAY SPRING
6	No Number	MOUNTING NUT
7	No Number	WASHER
8	No Number	MOUNTING PAD
		Attaching Parts Index 8
	No Number	MOUNTING STUD
9	18-3725-01	CONDENSER
10	03-1407-66	(3) WASHER
11	03-1417-09	(3) WASHER
12	03-1405-03	(3) SCREW
13	16-0271-00	(2) WATER HOSE ASSEMBLY
14	11-0198-00	WATER VALVE ASSEMBLY
		Attaching Parts Index 14
	03-1408-47	SCREW

# MF6B

## THE PARTS ILLUSTRATIONS AND PARTS LISTS

### SPOUT ASSEMBLY

ITEM NUMBER	PART NUMBER	DESCRIPTION
1	A14241-000	LIMIT BOX COVER
2	12-1018-00	SWITCH
	03-0886-00	Attaching Parts Index 2 SPEED NUT
3	<i>No Number</i>	INSULATION
4	03-0698-00	(3) SCREW
5	A16849-000	BOX LIMIT
6	A16670-000	PRESSURE PLATE
7	02-1321-00	SPRING
8	A25965-001	SPOUT ASSEMBLY
9	03-1407-07	WASHER
10	03-1420-02	SCREW
11	03-1417-16	LOCKWASHER
12	A16936-000	NUT
13	A20956-000	MALE-FEMALE BOLT (4)

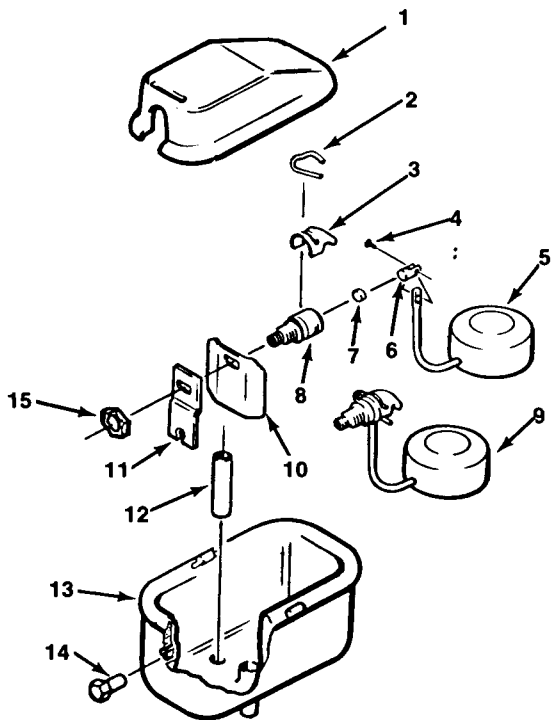
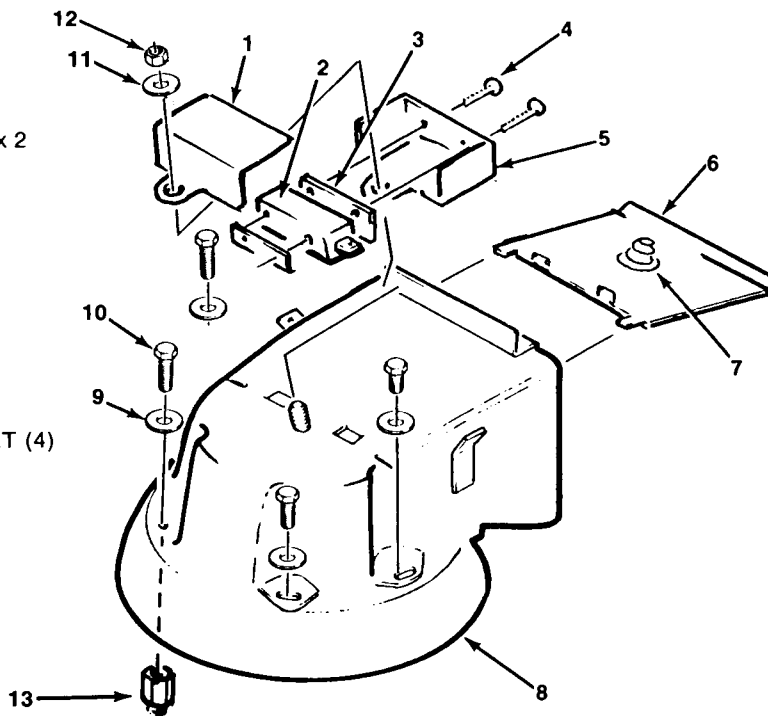

### RESERVOIR ASSEMBLY

ITEM NUMBER	PART NUMBER	DESCRIPTION
1	A12870-000	RESERVOIR COVER
2	02-1259-00	VALVE PIN
3	02-1320-00	DEFLECTOR
4	03-1001-00	RIVET
5	<i>No Number</i>	FLOAT
6	<i>No Number</i>	SEAT HOLDER
7	S06947-000	VALVE SEAT
8	<i>No Number</i>	WATER INLET VALVE
9	A09101-020	VALVE COMPLETE INCLUDES ITEMS 3, 7, 2, 4, 6, 8 & 5
10	A18418-000	WATER DEFLECTOR
11	A12869-000	BRACKET
12	S06715-000	STAND PIPE
13	A13413-000	RESERVOIR BODY
14	A08055-000	BRACKET NUT
15	S07044-000	NUT
	A08868-000	RESERVOIR COMPLETE (Less Items 1 and 12)

Not Available Separately  
\*Use Item 9

# MF6B THE PARTS ILLUSTRATIONS AND PARTS LISTS

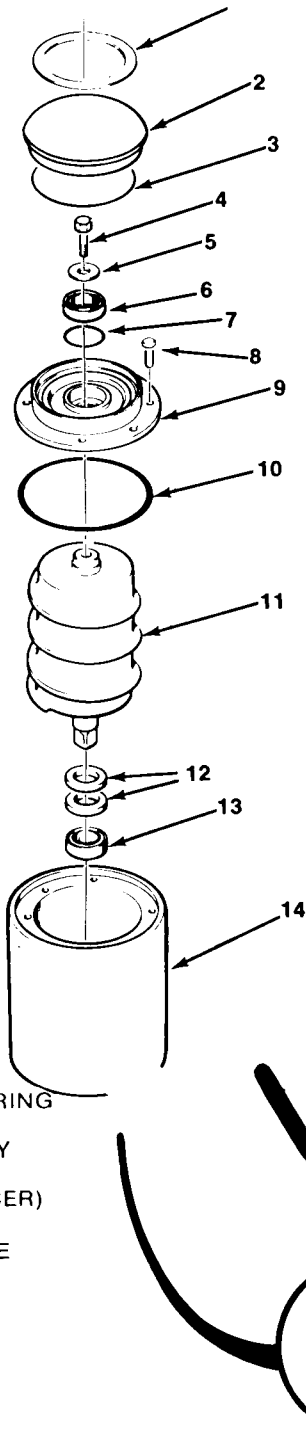

**NOTE:**

Ice breaker has ten holes around circumference, six of these are used to secure breaker to freezer barrel. The four remaining holes are threaded and are used to lift breaker and worm shaft up. You remove the six holding screws, re-insert (4) screws into lifter or threaded holes. These have no bottom on barrel and by evenly drawing them down, ice breaker and worm is lifted up.

**FREEZER ASSEMBLY**

ITEM NUMBER	PART NUMBER	DESCRIPTION
1	13-0617-18	"O" RING
2	13-0231-00	CAP ICE
3	A09047-000	CAP STYROFOAM
4	03-1450-36	HEX CAP SCREW
5	A06273-000	WASHER
6	02-0619-00	BEARING
7	13-0617-15	"O" RING
8	03-1405-25	HEX CAP SCREWS (6)
9	A11351-000	BREAKER ICE WITH BEARING
10	13-0617-17	"O" RING
11	A26075-001	WORM SHAFT ASSEMBLY
12	02-0776-01	SEAL WATER
13	02-0775-00	BEARING LOWER (SPACER)
14	A08858-020	REPAIR FREEZER SUCTION AND CAP TUBE ASSEMBLY
15	A25889-001	ASSEMBLY

**NOTE:**

Lower bearing or water seal should be removed by pulling from the top. If bearing is worn badly and cannot be removed with a bearing puller, it can be pushed out by using three (3) 1/4 x 20 screws three inches long inserted in the tapped holes provided in the lower bearing retainer.

# MF6B THE PARTS ILLUSTRATIONS AND PARTS LISTS

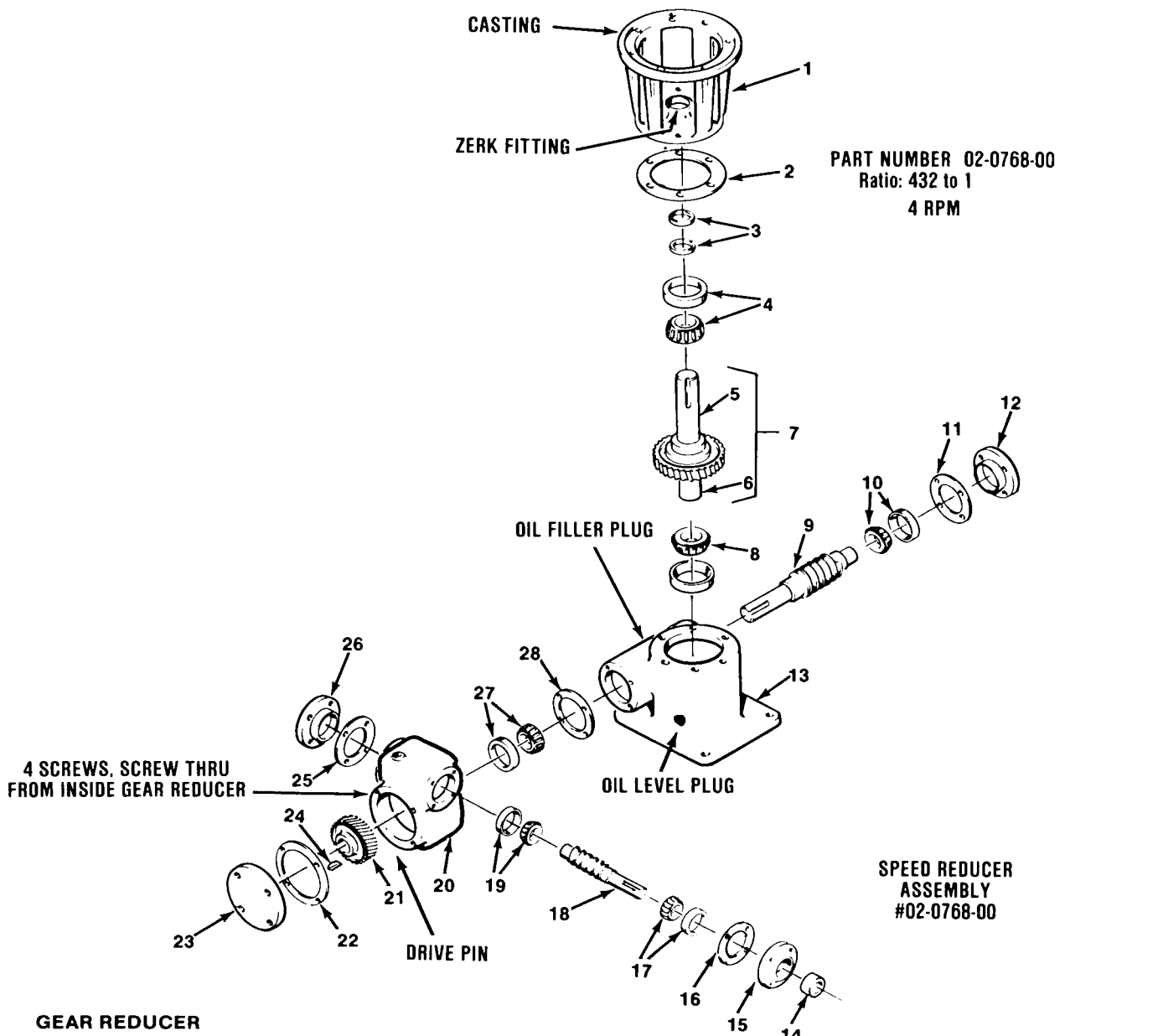

### GEAR REDUCER

ITEM NUMBER	PART NUMBER	DESCRIPTION
1	No Number	ADAPTOR
2	02-0768-28	COVER GASKET
3	02-0768-21	SLOW SPEED OIL SEAL
4	02-0268-22	SLOW SPEED BEARING
5	02-0768-30	SPACER LONG SLOW SPEED
6	02-0768-29	SPACER SHORT SLOW SPEED
7	02-0768-42	HI SPEED ATTACH HSG COVER
8	02-0768-22	SLOW SPEED BEARING
9	02-0768-38	WORM SHAFT
10	02-0768-23	INTERMEDIATE ROLLER BEARING
11	02-0768-26	HOUSING GASKET
12	No Number	END CAP
13	No Number	HOUSING

ITEM NUMBER	PART NUMBER	DESCRIPTION
14	02-0768-20	HIGH SPEED OIL SEAL
15	No Number	END CAP
16	02-0768-25	HIGH SPEED GASKET
17	02-0768-24	HIGH SPEED ROLLER BEARING
18	02-0768-39	WORM SHAFT
19	02-0768-24	HIGH SPEED ROLLER BEARING
20	No Number	HOUSING
21	02-0768-40	GEAR
22	02-0768-27	INTERMEDIATE GASKET
23	No Number	END CAP
24	02-0768-37	KEY AND ROLL PIN
25	02-0768-25	HIGH SPEED GASKET
26	No Number	END CAP
27	02-0768-23	INTERMEDIATE BEARING GASKET
28	02-0768-26	GASKET

# MF6B

## THE PARTS ILLUSTRATIONS AND PARTS LISTS

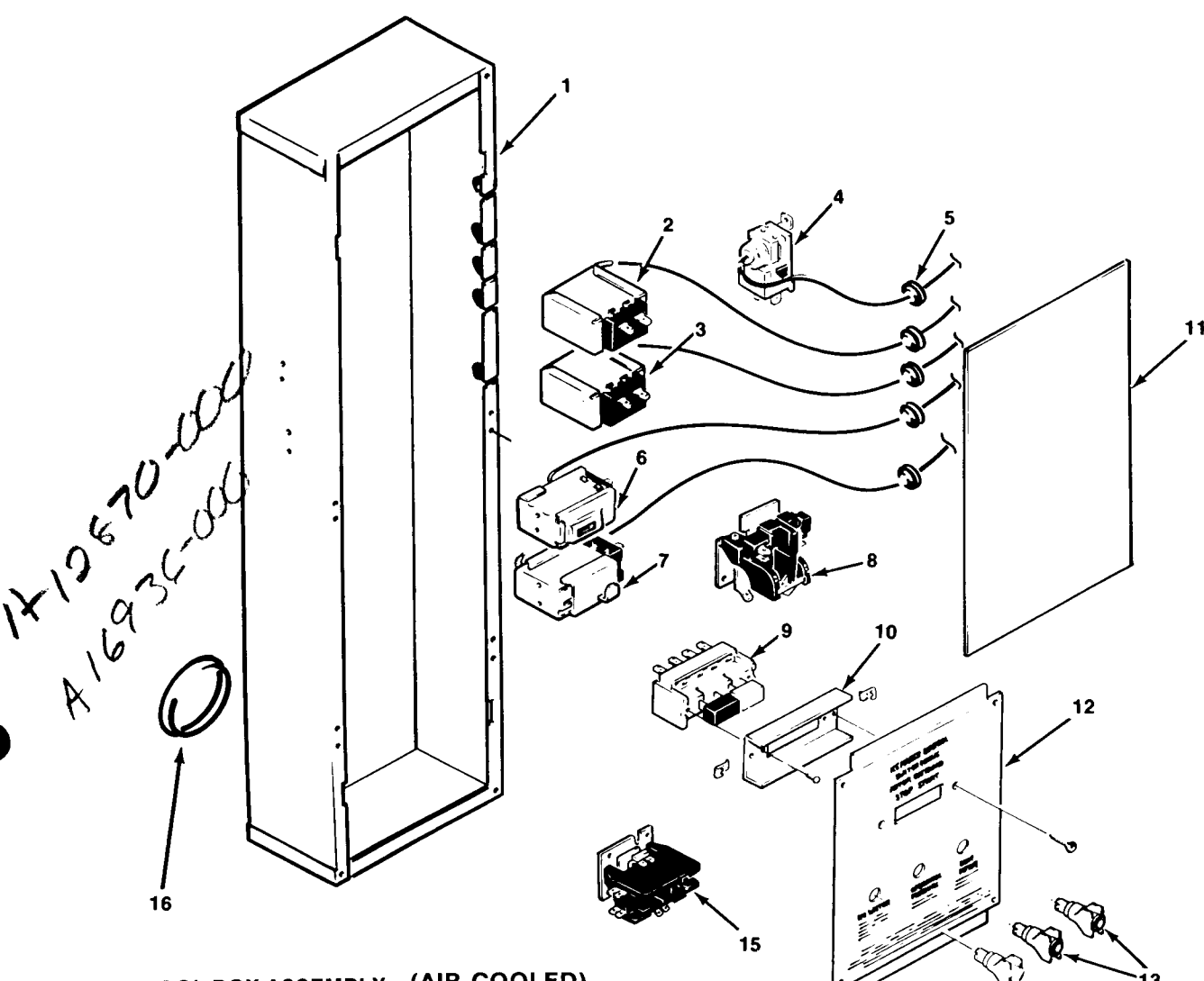

### CONTROL BOX ASSEMBLY (AIR-COOLED)

ITEM NUMBER	PART NUMBER	DESCRIPTION	ITEM NUMBER	PART NUMBER	DESCRIPTION
1	No Number	CONTROL BOX	8	12-2225-01	RELAY
2	11-0342-00	HIGH PRESSURE CONTROL (Air-Cooled Only) LEFT SIDE			Attaching Parts Index 8
		Attaching Parts Index 2	9	03-1403-26	SCREW 10 x 3/8
3	03-1403-02	SCREW 6 x 3/8		12-2227-01	SWITCH
	11-0343-00	HIGH PRESSURE CONTROL (Air-Cooled Only) RIGHT SIDE	10	03-1538-04	Attaching Parts Index 9
		Attaching Parts Index 3		No Number	SCREW 6 x 3/8
4	03-1403-02	SCREW 6 x 3/8	11	03-1423-01	SWITCH BRACKET
	11-0354-00	TEMPERATURE CONTROL		03-1419-12	Attaching Parts Index 10
		Attaching Parts Index 4	12	03-1423-01	(2) SPEED NUT
5	03-1403-17	SCREW 8 x 3/8		03-1419-12	(2) SCREW 6 x 7/8
6	13-0557-00	(5) GROMMET	13	No Number	COVER
7	11-0402-02	AUGER DELAY	14	No Number	CONTROL BRACKET
		Attaching Parts Index 6	15	03-1572-01	Attaching Parts Index 12
	03-1403-02	SCREW 6 x 3/8		12-1997-01	SCREW 8 x 1/2
	11-0358-00	LOW PRESSURE CONTROL	13	12-1997-01	LIGHT (RED)
		Attaching Parts Index 7	14	12-1997-02	LIGHT (AMBER)
	03-1403-02	SCREW 6 x 3/8	15	12-2037-02	CONTACTOR
		Attaching Parts Index 7		12-0739-02	CONTACTOR (3 PHASE)
	03-1403-02	SCREW 6 x 3/8	16	03-1403-26	Attaching Parts Index 15
		Attaching Parts Index 7		12-1213-15	SCREW 10 x 3/8
		Attaching Parts Index 7			BUSHING



# MF6B THE PARTS ILLUSTRATIONS AND PARTS LISTS

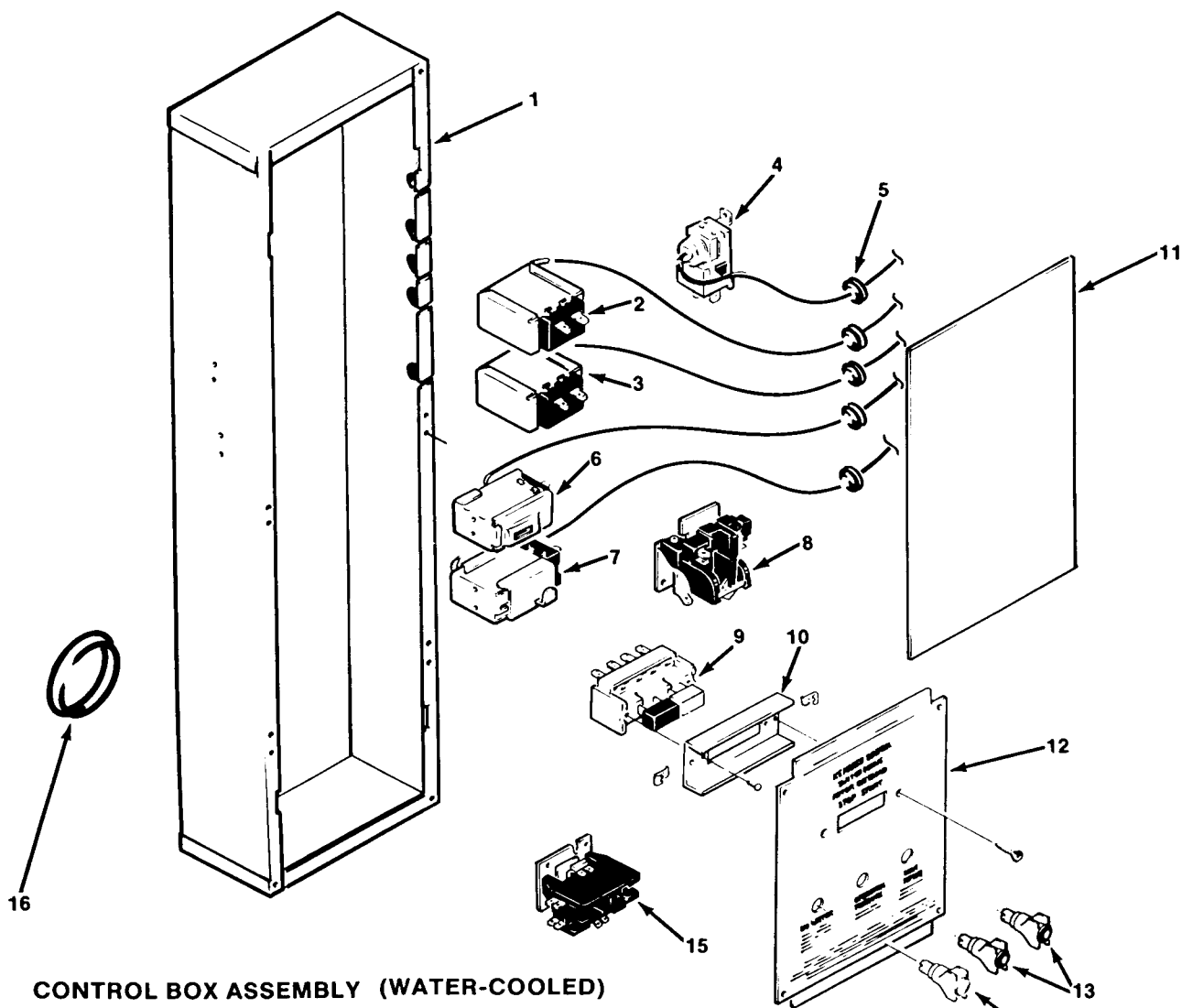

## CONTROL BOX ASSEMBLY (WATER-COOLED)

ITEM NUMBER	PART NUMBER	DESCRIPTION	ITEM NUMBER	PART NUMBER	DESCRIPTION
1	No Number	CONTROL BOX	8	12-2225-01	RELAY
2	11-0342-00	HIGH PRESSURE CONTROL (Air-Cooled Only) LEFT SIDE	9	03-1403-26	Attaching Parts Index 8
		Attaching Parts Index 2	9	12-2227-01	SCREW 10 x 3/8
		Attaching Parts Index 2	9	12-2227-01	SWITCH
3	03-1403-02 11-0343-00	SCREW 6 x 3/8 HIGH PRESSURE CONTROL (Air-Cooled Only) RIGHT SIDE	10	03-1538-04	Attaching Parts Index 9
		Attaching Parts Index 3	10	No Number	SCREW 6 x 3/8
4	03-1403-02 11-0354-00	SCREW 6 x 3/8 TEMPERATURE CONTROL	11	03-1423-01	SWITCH BRACKET
		Attaching Parts Index 4	11	03-1419-12	Attaching Parts Index 10
5	03-1403-17	SCREW 8 x 3/8	12	No Number	(2) SPEED NUT
6	13-0557-00	(5) GROMMET	12	No Number	(2) SCREW 6 x 7/8
7	11-0402-02	AUGER DELAY	13	03-1572-01	COVER
		Attaching Parts Index 6	13	12-1997-01	CONTROL BRACKET
8	03-1403-02 11-0358-00	SCREW 6 x 3/8 LOW PRESSURE CONTROL	14	03-1572-01	Attaching Parts Index 12
		Attaching Parts Index 7	14	12-1997-02	SCREW 8 x 1/2
9	03-1403-02	SCREW 6 x 3/8	15	12-2037-02	LIGHT (RED)
		Attaching Parts Index 7	15	12-0739-02	LIGHT (AMBER)
10	03-1403-02	SCREW 6 x 3/8	15	12-2037-02	CONTACTOR
		Attaching Parts Index 7	15	12-0739-02	CONTACTOR (3 PHASE)
11	No Number	COVER	16	03-1403-26	Attaching Parts Index 15
12	No Number	CONTROL BRACKET	16	12-1213-15	SCREW 10 x 3/8
13	03-1572-01	SCREW 8 x 1/2			BUSHING
14	12-1997-01	LIGHT (RED)			
15	12-1997-02	LIGHT (AMBER)			
16	12-2037-02	CONTACTOR			
	12-0739-02	CONTACTOR (3 PHASE)			

# MF6B WIRING DIAGRAMS

ALL CONTROLS SHOWN IN NORMAL ICE MAKING MODE

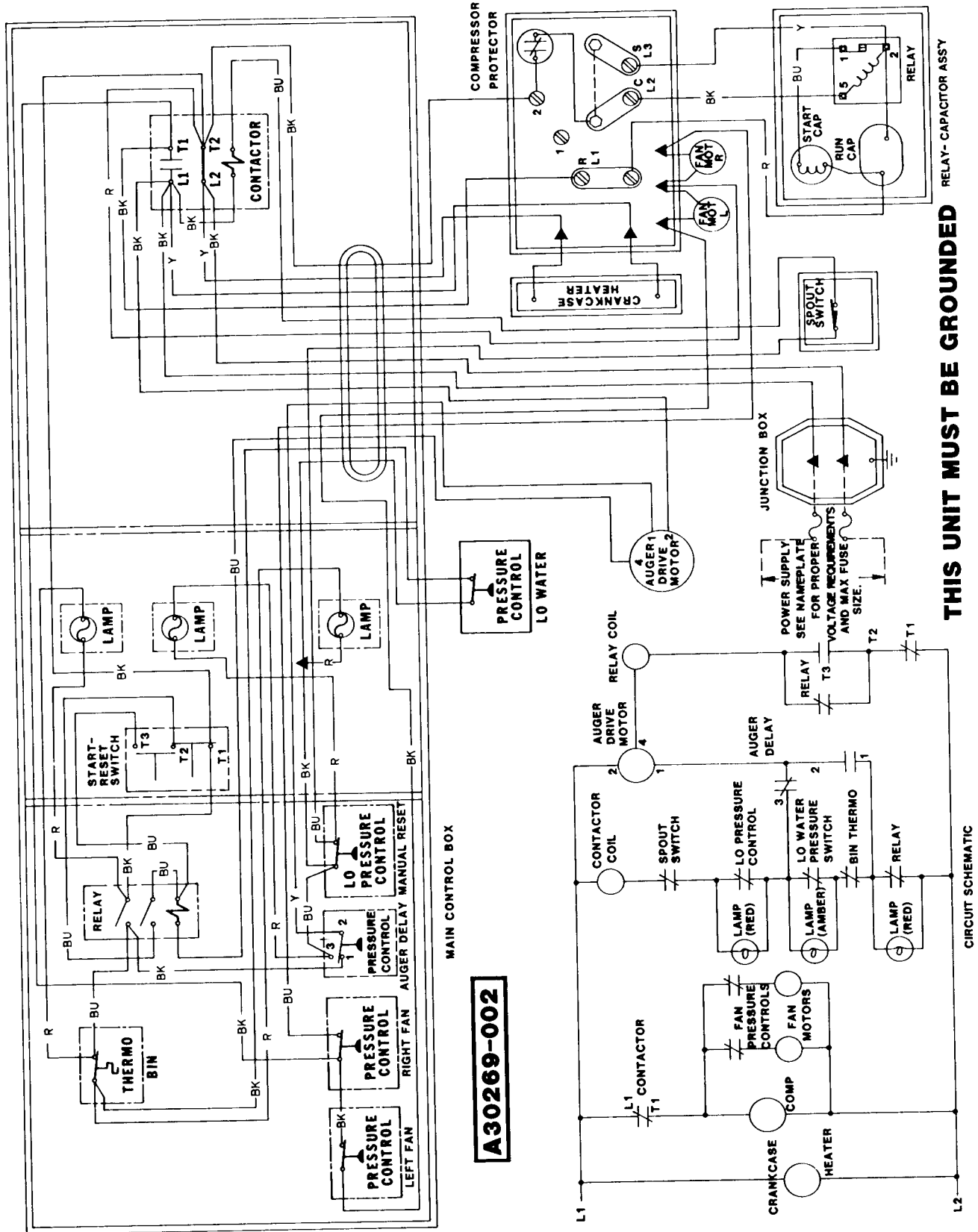

**THIS UNIT MUST BE GROUNDED**

Wiring Diagram Air-Cooled Model MF6B-2B (230/60/1)

# MF6B WIRING DIAGRAMS

ALL CONTROLS SHOWN IN NORMAL ICE MAKING MODE

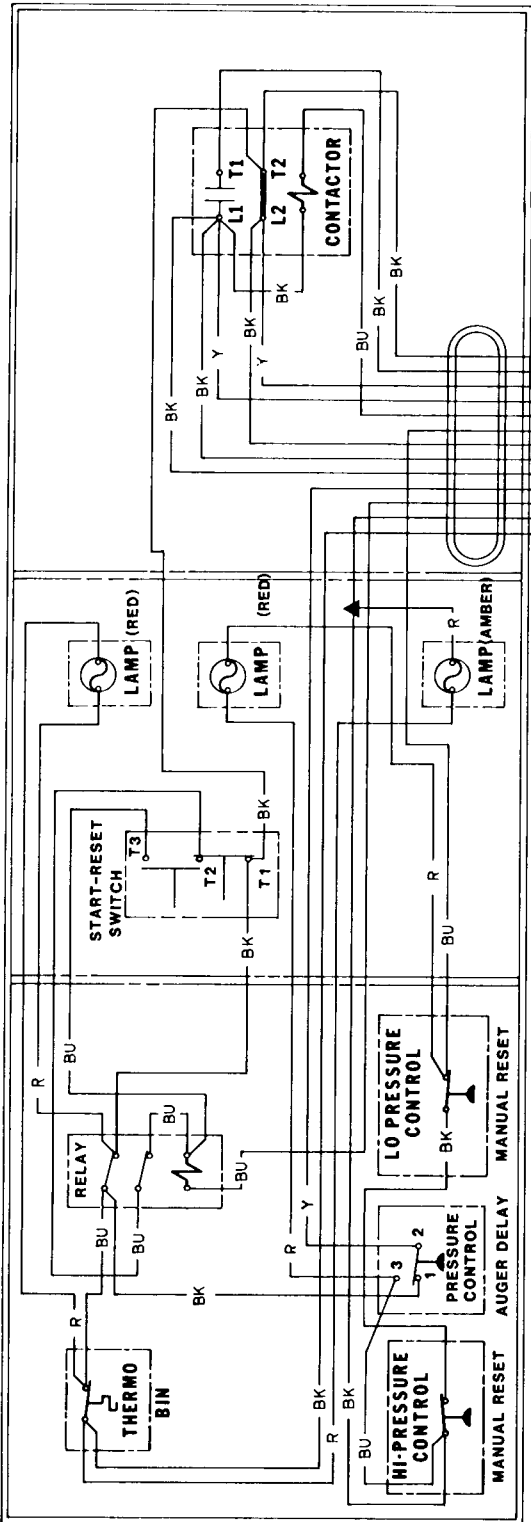

MAIN CONTROL BOX

**A30270-002**

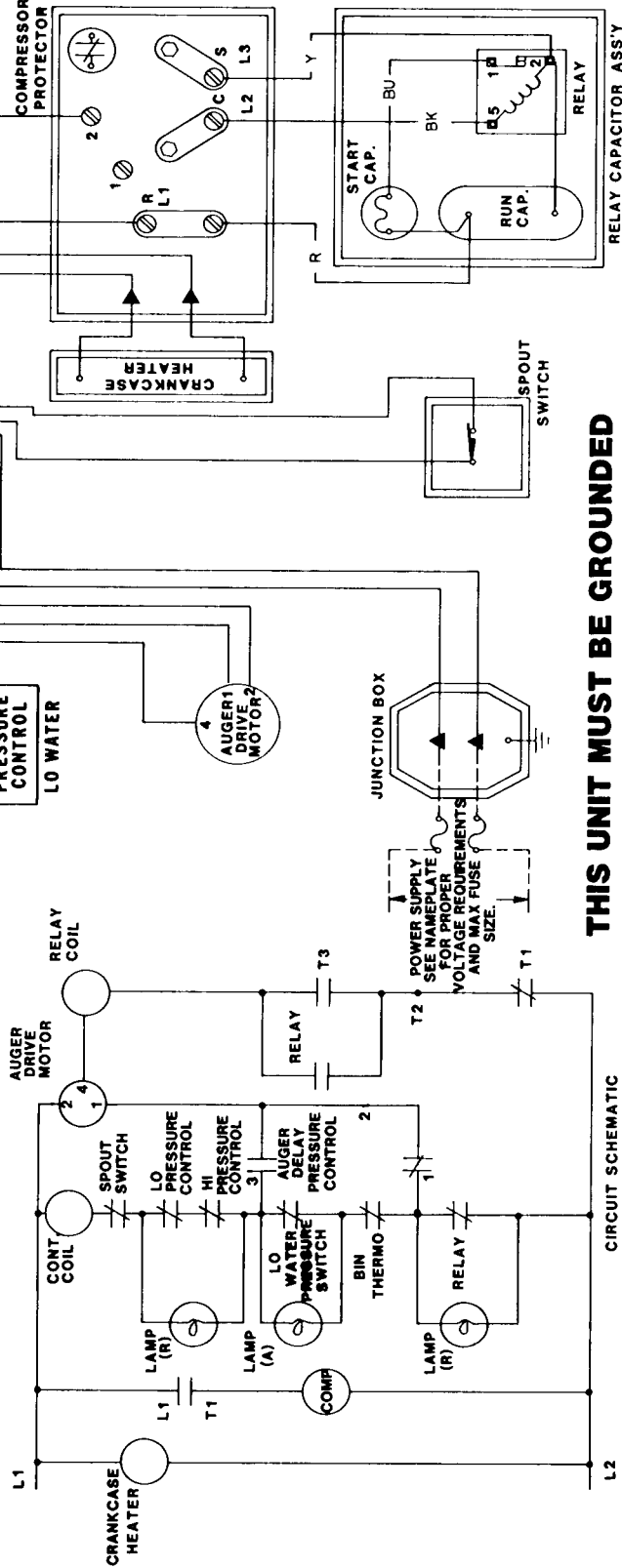

**THIS UNIT MUST BE GROUNDED**

Wiring Diagram Water-Cooled Model MF6B-2B (203/60/1)

# MF6B WIRING DIAGRAMS

ALL CONTROLS SHOWN IN NORMAL ICE MAKING MODE

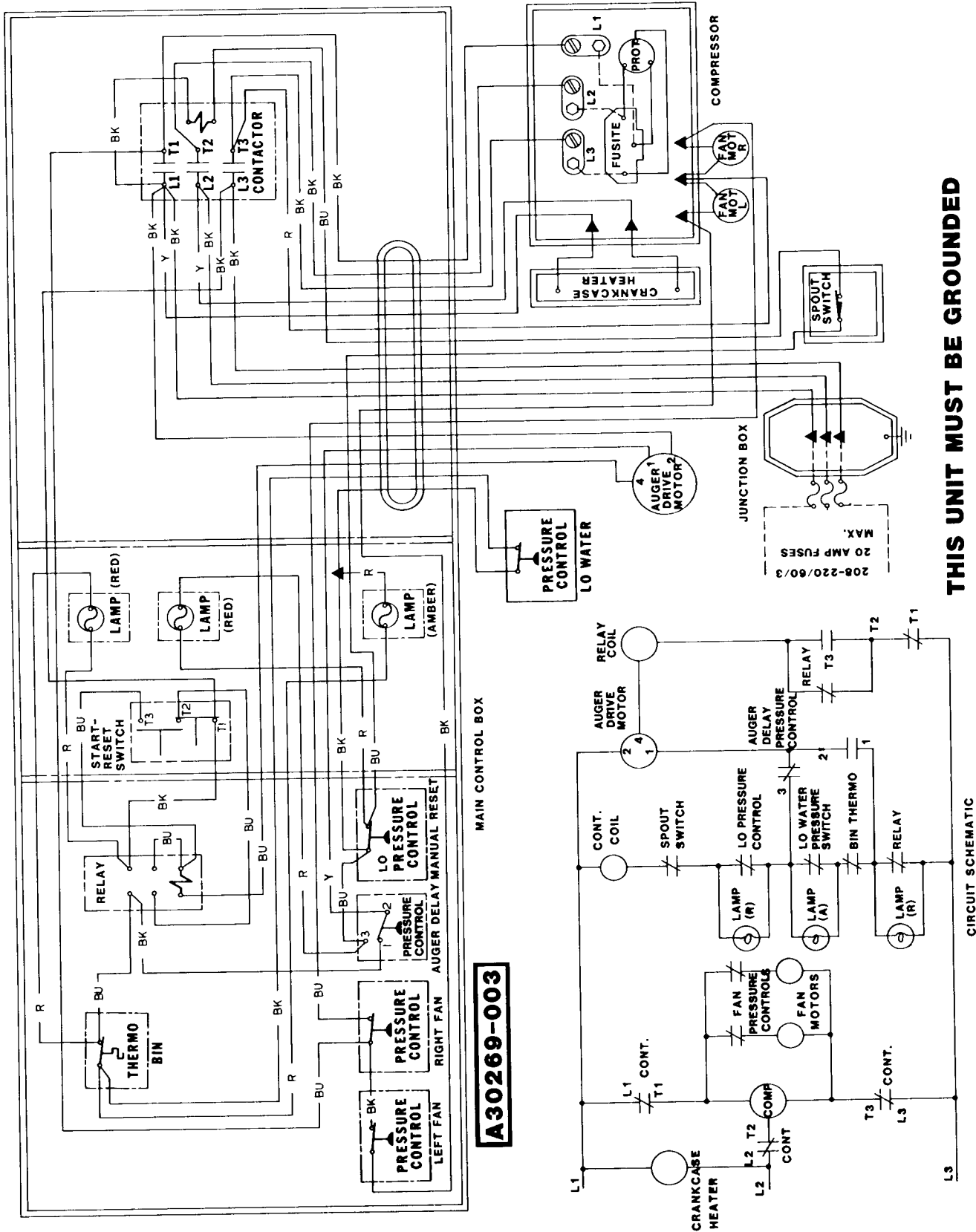

**THIS UNIT MUST BE GROUNDED**

Wiring Diagram Air-Cooled Model MF6B-2B (208/60/1 and 208-220/60/3)

# MF6B WIRING DIAGRAMS

ALL CONTROLS SHOWN IN NORMAL ICE MAKING MODE

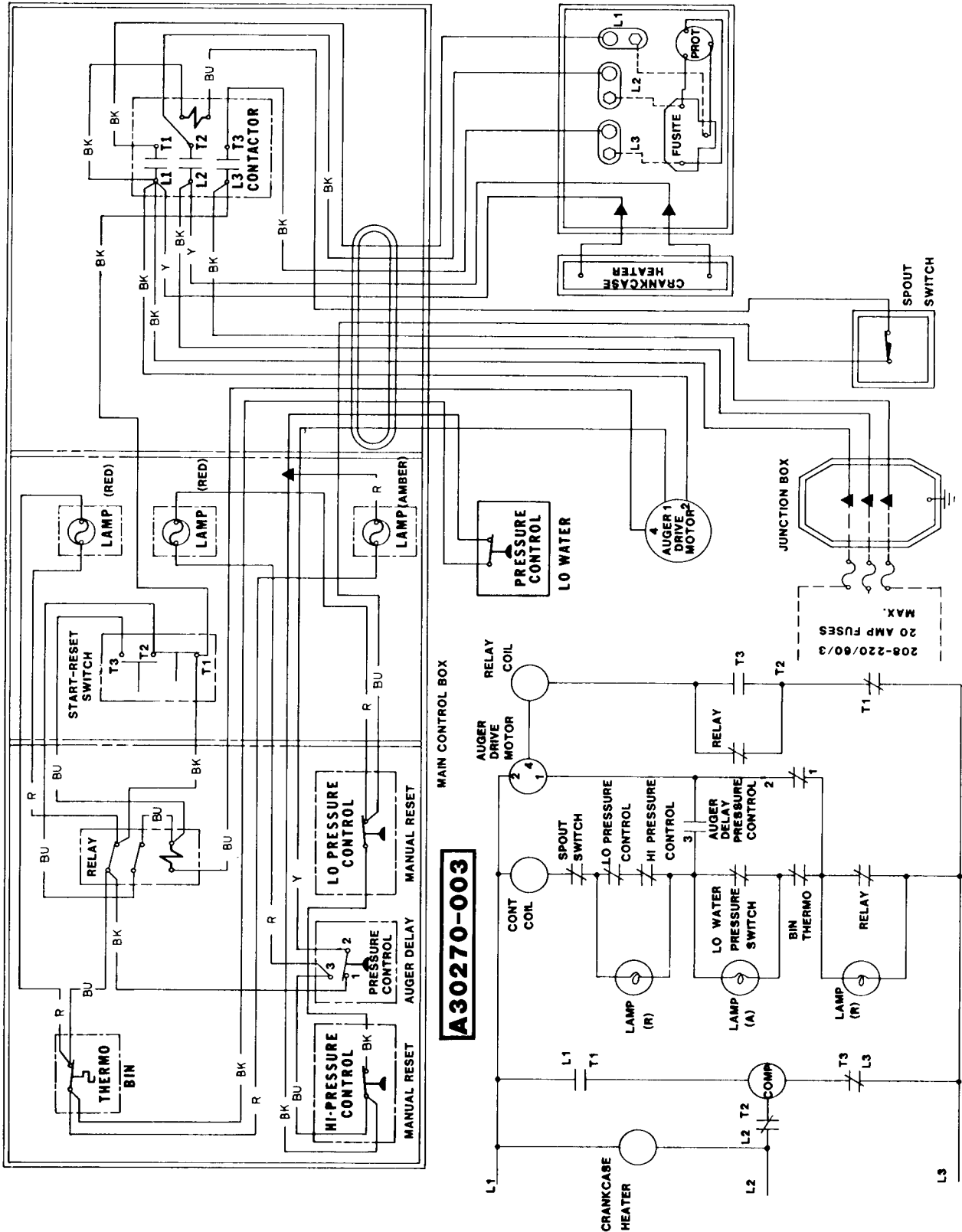

**THIS UNIT MUST BE GROUNDED**

CIRCUIT SCHEMATIC

Wiring Diagram Water-Cooled Model MF6B-3B (208/60/1 and 208-220/60/3)

# MF6B WIRING DIAGRAMS

ALL CONTROLS SHOWN IN NORMAL ICE MAKING MODE

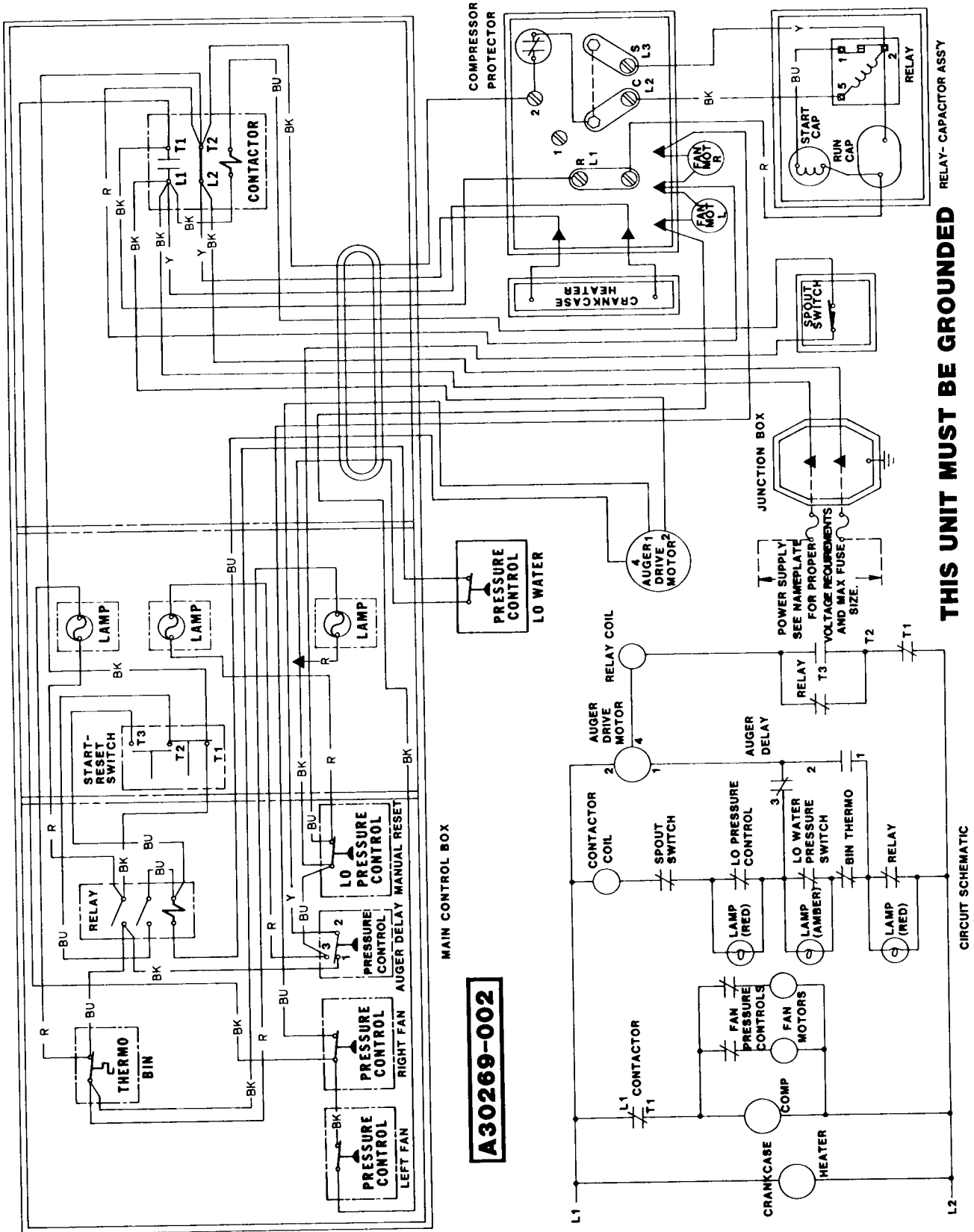

**THIS UNIT MUST BE GROUNDED**

Wiring Diagram Air-Cooled Model MF6B-7B (230/60/1)

# MF6B WIRING DIAGRAMS

ALL CONTROLS SHOWN IN NORMAL ICE MAKING MODE

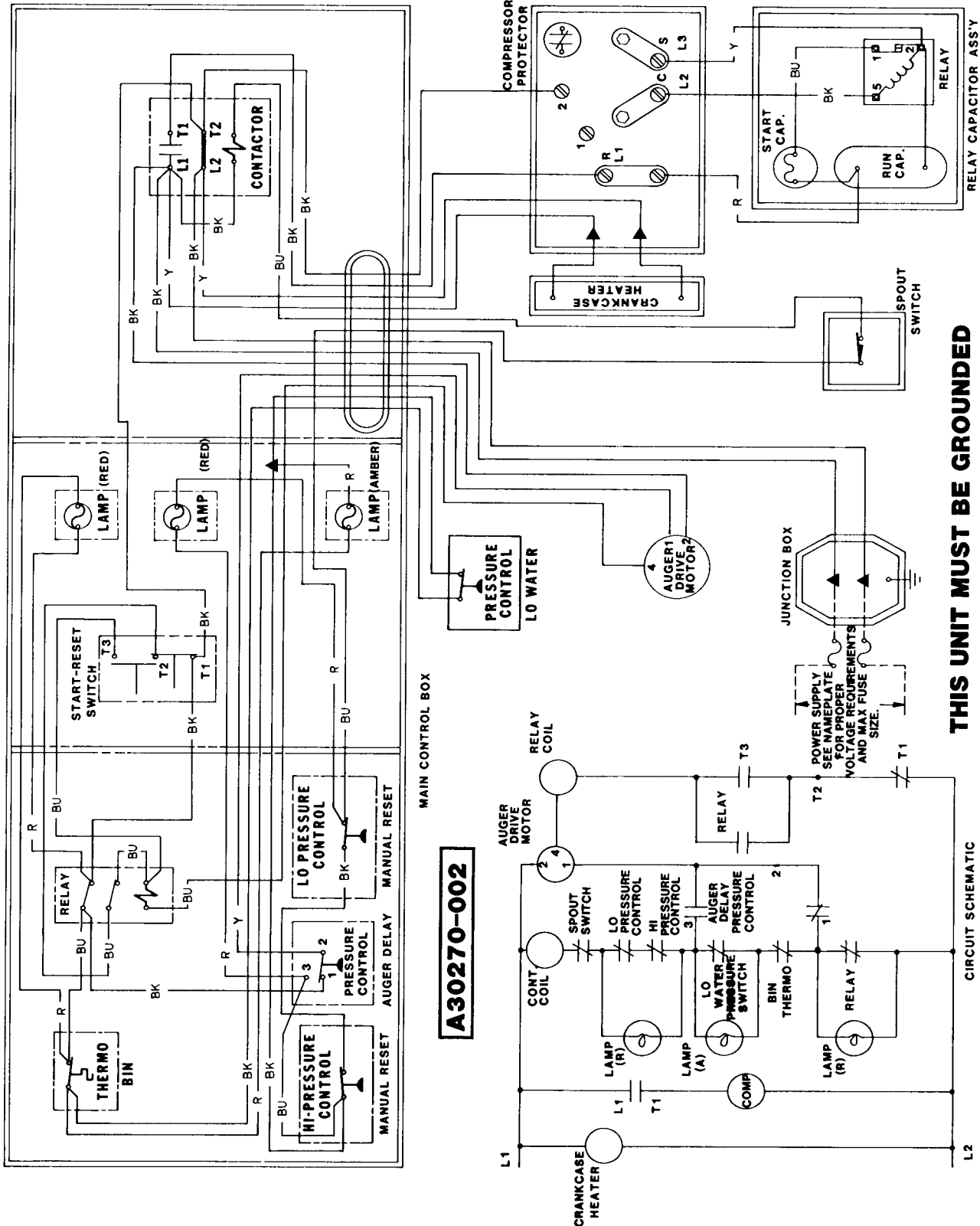

**THIS UNIT MUST BE GROUNDED**

Wiring Diagram Water-Cooled Model MF6B-7B (230/60/1)















# MF6B

## ADJUSTMENT AND REMOVAL AND REPLACEMENT

### REMOVAL AND REPLACEMENT OF THE CRANK CASE HEATER

1. Disconnect electrical power supply to icemaker at the fuse box or the circuit breaker.
2. Remove screws and cabinet panels to gain access to the bottom of the compressor.
3. Remove screws and the cover from the compressor junction box and disconnect electrical leads to crank case heater.
4. Remove screws and 90° connector from compressor junction box.
5. Using an open end wrench, remove two bolts which attach crank case heater to the bottom of the compressor and remove the crank case heater.
6. To replace the crank case heater, reverse the removal process.

### REMOVAL AND REPLACEMENT OF THE COMPRESSOR ASSEMBLY

1. Disconnect electrical power supply to icemaker at the fuse box or the circuit breaker.
2. Remove screws and cabinet panels to gain access to the compressor assembly.
3. Remove two screws and the cover from the Compressor junction box.
4. Disconnect the electrical leads at the compressor junction box.
5. Bleed off or blow the refrigerant charge through the Schrader valves.
6. Disconnect the suction line from the compressor.
7. Disconnect the discharge line from the compressor.
8. Disconnect four fittings and capillary tubes from the compressor head.

#### NOTE

*Water-Cooled models require uncoupling of the fittings of the water-cooled compressor drivemotor. Shut OFF the water valve to the water cooled condenser before proceeding with removal procedures.*

9. Remove four hex nuts, lockwashers and washers which secure the compressor to the chassis base.
10. Remove the compressor from the chassis.
11. To replace the compressor assembly, reverse the removal procedure.

#### NOTE

*Always install a replacement drier, anytime the sealed refrigeration system is opened. Do not replace the drier until all other repair or replacement has been completed.*

12. Thoroughly evacuate the system to remove moisture and non-condensables.
13. Charge the refrigeration system with R12 refrigerant, by weight. SEE NAMEPLATE for specifications.

### REMOVAL AND REPLACEMENT OF THE CONDENSER — AIR-COOLED MODELS

1. Disconnect electrical power supply to icemaker at the fuse box or the circuit breaker.
2. Remove screws and the cabinet panels to gain access to the condenser.
3. Bleed off or blow the refrigerant charge through the Schrader valve.
4. Unsolder and disconnect the condenser inlet tube at the condenser.
5. Unsolder and disconnect the condenser outlet tube at the condenser.
6. Remove two screws and lockwashers securing the condenser to the chassis base.
7. Remove the condenser from the chassis and remove fan shroud from condenser.
8. To replace the condenser, reverse the removal procedures.

#### NOTE

*Always install a replacement drier, anytime the sealed refrigeration system is opened. Do not replace the drier until all other repair or replacement has been completed.*

9. Thoroughly evacuate the system to remove moisture and non-condensables.
10. Charge the refrigeration system with R12 refrigerant, by weight. SEE NAMEPLATE for specifications.

### REMOVAL AND REPLACEMENT OF THE CONDENSER — WATER-COOLED MODELS

1. Disconnect electrical power supply to icemaker at the fuse box or the circuit breaker.
2. Remove screws and cabinet panels to gain access to the condenser.
3. Bleed off or blow the refrigerant charge through the Schrader valve.
4. Unsolder the refrigerant inlet and outlet lines from the condenser.
5. Disconnect the water inlet and outlet lines from the condenser.
6. Remove three bolts and lockwashers which secure the condenser to the chassis mounting base.
7. Remove the condenser from the cabinet.
8. To replace the condenser, reverse the removal procedures.

# MF6B ADJUSTMENT AND REMOVAL AND REPLACEMENT

## ADJUSTMENT OF THE WATER REGULATOR ASSEMBLY

The correct head pressure on Water-Cooled models is 135 PSIG. Adjustments can be performed on the Water Regulator Assembly to increase or decrease the head pressure.

To Adjust the Water Regulator Assembly:

- A. To INCREASE the Head Pressure: Rotate the adjusting Screw, on the Water Regulator Assembly IN or CLOCKWISE.
- B. To DECREASE the Head Pressure: Rotate the adjusting Screw, on the Water Regulator Assembly OUT or COUNTERCLOCKWISE.

## ADJUSTMENT OF THE WATER RESERVOIR FLOAT

The correct water level in the Water Reservoir should be 3/8-inch below the top of the overflow tube. When the water level is above or below this level, adjustment can be performed by carefully bending the arm attached to the float.

## ADJUSTMENT OF THE WATER LEVEL IN THE FREEZER ASSEMBLY

The correct water level in the freezer assembly should be just below the bottom of the ice breaker assembly.

1. To RAISE the water level: Remove the three screws which attach the water reservoir assembly to the mounting bracket and RAISE the water reservoir assembly the desired amount; then replace and tighten the screws.
2. To LOWER the water level: Remove the three screws which attach the water reservoir assembly to the mounting bracket and LOWER the water reservoir assembly the desired amount; then replace and tighten the screws.

### WARNING

**Be sure the electrical power supply and the water supply are OFF, before starting any of the following REMOVAL AND REPLACEMENT procedures, as a precaution to prevent possible personal injury or damage to equipment.**

## REMOVAL AND REPLACEMENT OF THE AUGER, WATER SEAL AND BEARINGS

1. Disconnect the electrical power to the icemaker at the circuit breaker or fuse box.
2. Shut OFF inlet water valve to the icemaker.
3. Remove screws and cabinet panels to gain access to the freezer assembly.
4. Remove four bolts and spout assembly to gain access to the icebreaker assembly.
5. Remove protector ring, o-ring, rubber cap and styrofoam cap from ice breaker assembly.
6. Remove six hex head screws around perimeter of ice breaker and thread four bolts into four unused holes around ice breaker and tighten evenly to pull icebreaker, auger and lower water seal from the freezer assembly. If lower bearing cannot be removed using a bearing puller, three 1/4 x 20 x 3-inch long screws may be threaded into the holes provided in the bottom of the freezer assembly to push the bearing up and out of the freezer assembly.
7. To replace lower bearing in the freezer assembly, use a press to push the lower bearing into position.
8. Inspect the o-rings for cuts, tears and general worn condition to determine replacement.
9. Inspect the bearing pressed into the top of the ice breaker. If it is to be replaced, use a press to push the upper bearing into position in the ice breaker.

### NOTE

*Anytime the auger is removed for replacement, or for the inspection and replacement of the bearings, use extra care in handling the water seal parts so no dirt or foreign matter are deposited on the surfaces of the seal.*

*If there is any doubt about the effectiveness of the water seal or o-rings, REPLACE THEM. A dirty, worn or faulty water seal or o-ring will cause a leak and ultimately require a second, time consuming removal and replacement procedure to be performed, that COULD HAVE BEEN PREVENTED.*

10. To replace the auger, water seal, bearings, and ice breaker assembly, reverse the removal procedure.

# MF6B ADJUSTMENT AND REMOVAL AND REPLACEMENT

## NOTE

*Always install a replacement drier, anytime the sealed refrigeration system is opened. Do not replace the drier until all other repair or replacement has been completed.*

9. Thoroughly evacuate the system to remove moisture and non-condensables.
10. Charge the refrigeration system with R12 refrigerant, by weight. SEE NAMEPLATE for specifications.

## REMOVAL AND REPLACEMENT OF THE DRIER

### NOTE

*Always install a replacement drier, anytime the sealed refrigeration system is opened. Do not replace the drier until all other repair or replacement has been completed.*

1. Disconnect electrical power supply to icemaker at the fuse box or the circuit breaker.
2. Remove screws and the cabinet panels to gain access to the drier.
3. Remove screw and drier brace attaching the drier to the chassis base.
4. Bleed off or blow the refrigerant charge through the Schrader valve.
5. Unsolder refrigeration lines at each end of drier, remove the drier and separate the drier from the drier brace.

## CAUTION

**1. If the factory seal is broken on the replacement drier, exposing it to the atmosphere more than a few minutes, the drier will absorb moisture from the atmosphere and lose substantial ability for moisture removal.**

**2. Be sure the replacement drier is installed with the arrow positioned in the direction of the refrigerant flow.**

6. Remove the factory seals from the replacement drier and install the drier in the refrigerant lines with the arrow positioned in the direction of the refrigerant flow.
7. Install the drier brace on the drier.
8. Solder the drier into the lines, two places.
9. Purge the system and check for leaks.
10. Thoroughly evacuate the system to remove moisture and non-condensables.
11. Charge refrigeration system with R12 refrigerant, by weight. SEE NAMEPLATE for specifications.

## REMOVAL AND REPLACEMENT OF THE DRIVEMOTOR ASSEMBLY

1. Disconnect electrical power supply to icemaker at the fuse box or the circuit breaker.
2. Remove screws and cabinet panels to gain access to drivemotor.
3. Loosen screw clamp from coupler on drivemotor end.
4. Remove bolts, lockwashers and washers which attach the drivemotor to the mounting bracket.
5. Disconnect electrical leads to drivemotor.
6. Lift the drivemotor from the chassis base and remove from the cabinet.
7. To replace the drivemotor assembly, reverse the removal procedure.

## REMOVAL AND REPLACEMENT OF THE FAN MOTOR ASSEMBLY — AIR-COOLED MODELS

### NOTE

*Before beginning this procedure, observe the fan blade position on the shaft of the fan motor and mark the fan blade so it will be correctly positioned during reassembly. Direction of air flow should be toward the fan motor.*

1. Disconnect electrical power supply to icemaker at the fuse box or the circuit breaker.
2. To remove the defective fan motor assembly, remove screws and the cabinet panels to gain access to the fan motor.
3. Disconnect the electrical lead from the defective fan motor.
4. Remove four screws securing the fan motor bracket to the chassis.
5. Remove the set screw from the fan blade. Remove the fan blade from the motor shaft.
6. Remove four screws securing the fan mounting bracket to the fan motor and separate the motor from the brackets.
7. To replace the fan motor assembly, reverse the removal procedure.

## REMOVAL AND REPLACEMENT OF FREEZER ASSEMBLY

1. Disconnect electrical power supply to icemaker at the fuse box or the circuit breaker.
2. Close water inlet valve to icemaker.
3. Remove screws and cabinet panels to gain access to the freezer assembly.
4. Remove thumb screws on ice chute and remove ice chute cover.
5. Remove bolts and washers and the ice spout assembly.
6. Remove corbin clamp and water feed tube to the freezer assembly.



## MF6B ADJUSTMENT AND REMOVAL AND REPLACEMENT

7. Remove bolts attaching the bottom of the freezer assembly to worm gear reducer.
8. Bleed off or blow the refrigerant charge through Schrader valve.
9. Pull back insulation and unsolder suction line and capillary tube from the freezer assembly. Use water soaked rags to protect flammable parts.
10. Lift freezer assembly and remove from the worm gear reducer.
11. To replace freezer assembly, reverse the removal procedures.

### NOTE

*Always install a replacement drier anytime the sealed refrigeration system is opened. DO NOT replace drier until all other repair or replacement has been completed. Thoroughly evacuate the system to remove moisture and non-condensables.*

12. Recharge refrigeration system with R12 refrigerant. SEE NAMEPLATE as per specifications.

### REMOVAL AND REPLACEMENT OF THE LOW WATER PRESSURE CONTROL

1. Disconnect electrical power supply to icemaker at the fuse box or the circuit breaker.
2. To remove the lo water pressure control, remove screws and the cabinet panels to gain access to the lo water pressure control.
3. Disconnect the electrical leads of the lo water pressure control.
4. Unscrew the flare nut fitting and disconnect the lo water pressure control from the inlet water tubing.

### NOTE

*Inspect the o-ring and retain for the replacement. Replace o-ring that is cut, torn or indicates excessive wear.*

5. To replace the Lo Water Pressure Control, reverse the removal procedure.

### REMOVAL AND REPLACEMENT OF THE WATER REGULATOR ASSEMBLY — WATER-COOLED MODELS

1. Disconnect electrical power supply to icemaker at the fuse box or the circuit breaker.
2. Close water inlet valve to the icemaker.
3. Remove screws and the cabinet panels to gain access to the water regulator assembly.
4. Bleed off or blow the refrigerant charge through the Schrader valve.
5. Unsolder the capillary tube from the water regulator assembly.
6. Disconnect the water inlet and outlet line of the water regulator.
7. Disconnect the electrical lead to the water regulator assembly.
8. To replace the water regulator assembly, reverse the removal procedures.

### NOTE

*Always install a replacement drier, anytime the sealed refrigeration system is opened. Do not replace the drier until all other repair or replacement has been completed.*

### REMOVAL AND REPLACEMENT OF THE WATER RESERVOIR ASSEMBLY

1. Disconnect electrical power supply to icemaker at the fuse box or the circuit breaker.
2. Close inlet water valve to the icemaker.
3. Remove screws and cabinet panels to gain access to the reservoir assembly.

### NOTE

*To prevent draining water on parts, components, electrical lines, etc., be prepared with container or rags to catch water left in lines.*

4. Disconnect the water inlet tube from the water reservoir assembly.
5. Remove overflow stand pipe from reservoir to drain water from reservoir.
6. Remove two corbin clamps and two tubes from the bottom of the water reservoir assembly.
7. Remove three screws at the base of the water reservoir.
8. Lift and remove the water reservoir assembly from the mounting bracket.
9. To replace the water reservoir assembly, reverse the removal procedures.

# SERVICE DIAGNOSIS

The Service Diagnosis Section is for use in aiding the serviceman in diagnosing a particular problem for pin-pointing the area in which the problem lies, thus an ever available reference for proper corrective action.

The following charts list corrective action for the causes of known symptoms of certain problems that can occur in the Icemaking-Refrigeration System.

SYMPTOM	POSSIBLE CAUSE	CORRECTION
Water Leaks	Defective water seal. Gravity feed line leaking. Water level in reservoir too high.	Replace Seal. Check hose clamps. Adjust water level to 3/8 inch below reservoir overflow, then raise reservoir until water flows out freezer spout, then lower reservoir 3/4-inch.
	Storage bin drain and connecting fittings.	Check and repair as necessary.
Excessive noise or chattering.	Mineral or scale deposit on auger and inner freezing chamber walls.	For severe deposit, remove and manually polish auger, sand inner chamber walls of freezer barrel. For lighter concentration, use Scotsman Ice Machine Cleaner periodically.
	Misaligned drive coupling. Gear reducer low on oil charge.	Repair or replace. Check oil level and refill to oil level plug.
	Intermittent water supply.	Check and clean water strainer. Check gravity feed line for air lock. Remove air lock.
	Water level in reservoir too low.	See CORRECTION for Water Leaks above.
	Gear reducer loose on frame. Motor compressor not floating on springs. Drivemotor loose on mount, end-play or worn bearing.	Tighten gear reducer. Repair or replace rubber mounts. Tighten, repair or replace as necessary.
Making wet ice. (Ice melts too quickly, is not cold enough to properly cure in the Bin.)	Extreme high ambience.	Correct or move cabinet to cooler location.
	Under or over-charge of refrigerant.	Recharge with proper amount. Should frost out of accumulator at least 8-inches. See nameplate for correct charge. See CORRECTION for Water Leaks above.
	High water level in water reservoir.	See CORRECTION for Water Leaks above.

## MF6B SERVICE DIAGNOSIS

SYMPTOM	POSSIBLE CAUSE	CORRECTION
Making wet ice (Cont'd)	<p>Back Pressure too high</p> <p>Faulty compressor or valve plate</p>	<p>Overcharge of refrigerant. Faulty compressor or high head pressure. Lower pressure as indicated.</p> <p>Repair or replace compressor or valve plate.</p>
Low ice production	<p>Loss of refrigerant. Under or over-charge of refrigerant.</p> <p>Drivemotor weak.</p> <p>Dirty or plugged condenser.</p> <p>Low water level in water reservoir.</p> <p>Overcharge of oil in system.</p> <p>Partial restriction in capillary tube or drier.</p> <p>Inlet water strainer partially plugged.</p> <p>Corroded or stained auger due to water condition.</p>	<p>Check and recharge. See NAMEPLATE for correct charge.</p> <p>Replace Drivemotor.</p> <p>Clean condenser.</p> <p>See CORRECTION for Water leaks above.</p> <p>Check at oil sight glass. Lower to 1/2 sight glass.</p> <p>Moisture in system. Overcharge of oil in system. Remove charge by blowing back through cap tube. Replace drier and recharge.</p> <p>Remove screen and clean.</p> <p>Remove auger and clean, or use Scotsman Ice Machine Cleaner. See Maintenance Section.</p>
Gearmotor noise.	Low on oil.	Remove case cover to check for proper oil level. Top of gears should be covered. Use: Sun Oil Company Prestige 50-EP.
Icemaker will not operate.	<p>Power interruption will stop ice maker.</p> <p>Blown fuse in line.</p> <p>Bin thermostat set too high.</p> <p>Loose electrical connection.</p> <p>Switch in OFF position.</p> <p>Inoperative master switch or red reset.</p> <p>Off on manual-reset pressure control.</p>	<p>Press Master Reset Push Button to re-start.</p> <p>Replace fuse and check for cause of blown fuse.</p> <p>Adjust thermostat. Set at 35-degrees cut-out, 45-degrees cut-in or replace.</p> <p>Check wiring.</p> <p>Set switch to ON position.</p> <p>Replace switch or thermal overload.</p> <p>Reset.</p>
Icemaker continues to operate with full storage bin.	Bin thermostat not properly set or is defective.	Re-set or replace bin thermostat. Re-set to 35-degrees cut-out, 45-degrees cut-in.

## MF6B SERVICE DIAGNOSIS

SYMPTOM	POSSIBLE CAUSE	CORRECTION
Compressor cycles intermittently.	Low voltage.	Check for overloading.
	Dirty condenser.	Clean condenser.
	Air circulation blocked.	Remove cause or move unit.
	Inoperative condenser fan motor.	Replace motor.
	Non-condensable gases in system.	Check for gas leaks, evacuate and recharge.
	Bin thermostat differential too small causing short cycling.	Widen differential 35-degrees cut-out, 45-degrees cut in.
Icemaker operates but makes no ice.	Low water pressure.	Restore.
	Water not entering freezing chamber.	Plugged strainer or supply line. Check and clean. Air lock in gravity feed line. Check and remove air lock.
	Moisture in system.	Check, evacuate, replace drier. Recharge, See NAMEPLATE for correct charge.
	Water seal leaking.	Replace seal.
	Defective manual overload switch.	Replace switch.
	Drivemotor or drive coupling stripped.	Repair or replace drivemotor or drive coupling.

# MAINTENANCE AND CLEANING INSTRUCTIONS

## GENERAL

The periods and procedures for maintenance and cleaning are given as guides and are not to be construed as absolute or invariable. Cleaning especially will vary, depending upon local water conditions and the ice volume produced, each Icemaker must be maintained individually in accordance with its own particular location requirements.

## ICEMAKER

THE FOLLOWING MAINTENANCE SHOULD BE SCHEDULED AT LEAST TWO TIMES PER YEAR ON THIS ICEMAKER. CALL YOUR AUTHORIZED SCOTSMAN SERVICE AGENCY.

1. Check and clean water line Strainers.
2. Remove cover from Water Reservoir and depress the float to ensure that a full stream of water enters the Reservoir.
3. Check that the Icemaker cabinet is level, in side-to-side and front-to-rear directions.
4. Check that the water level in the Water Reservoir is below the overflow, but high enough that it does not run out of the spout opening.

### NOTE

*It is normal for some water to emerge from the Ice Spout with flaked ice during normal ice production.*

5. Clean the Water Reservoir and interior of the Freezer Assembly, using a solution of SCOTSMAN Ice Machine Cleaner. Refer to procedure V-III, Cleaning - Icemaker.

One cleaning per year should be a manual cleaning; Stainless steel auger should be removed and buffed to a mirror-like finish, use buffing wheel and jewelers rouge. Inner freezer barrel should be sanded using vertical strokes with 100 grit wet or dry paper.

### NOTE

*Cleaning requirements vary according to local water conditions and individual user operation. Visual inspection of the Auger before and after cleaning will indicate frequency and procedure to be followed in local areas.*

6. When doubtful about refrigerant charge, install refrigerant gauges on Schrader valves and perform steps 6 and 7.

Check gauge for Compressor head pressure: AIR-COOLED MODELS: Varies between 130 to 145 PSIG. WATER-COOLED MODELS: Set at 135 PSIG. Adjust screw on top of Water Regulator Valve to raise or lower head pressure.

7. Check gauge for Suction line pressure:

Varies between 12 to 16 PSIG, depending upon inlet water temperature and ambient air temperature.

8. Set hand reset low pressure control to cut off in event of water supply interruption, or low ambient temperature at approximately 0 PSI to 4 PSI.
9. With compressor operating and oil settled, check crankcase oil level. The proper oil level is between 1/4 and 3/4 up on sight glass. Add refrigerant oil if required.
10. Remove gear reducer drain plug to change oil. Use Mobil Oil #600W or equivalent grade of gear oil with a viscosity of 125 to 190. For models with grease fittings use Mobil grease BRB No. 1 or any good grade ball bearing grease. Particularly important when there is evidence that water may have entered gear housing.
11. Oil drive motor. Use SAE No. 10 oil.
12. Check top bearing on freezer. Remove rubber O-Ring, rubber cap, and styrofoam cap. If moisture is around bearing, wipe clean and use Beacon No. 325 or equivalent. Check and adjust drive motor coupling.

### NOTE

*BEFORE next step, press the manual OFF push button switch on the front of the Control Box, to the OFF position to stop the Fan Motors and Icemaker.*

13. Clean the Air-Cooled Condenser, using vacuum cleaner, whisk broom, or brush. Instruct customer to clean frequently and to be sure Icemaker and Fan Motor are OFF.
14. Check that Fan Blades move freely and are not touching any surfaces or bent or out of balance.
15. Check for refrigerant leaks and for proper frost line, which should frost out of accumulator at least half way to the compressor and in some areas, back to service valve.
16. Check for water leaks. Tighten drain line connections. Pour water down Bin drain to be sure that drain line is open and clear.
17. Check the quality of ice. Ice flakes should be wet when formed, but will cure rapidly to normal hardness in the Bin.
18. Check the Bin Thermostatic Ice Control Bulb.

### NOTE

*The Bin Thermostat is factor set at 10-degrees F. differential and should keep the entire Icemaker*

## MF6B MAINTENANCE AND CLEANING INSTRUCTIONS

system shut off at least 20 minutes in high ambient temperatures, longer in low ambient temperatures during normal operation. Settings are 35-degrees F. CUT-OUT and 45-degrees F. CUT-IN.

19. Check the Spout Switch.

### NOTE

*If Bin Thermostat Bulb were to fail and cause ice to jam up in the Ice Spout, the Spout Switch is manually reset and functions as a safety switch to automatically stop the icemaking process.*

### CLEANING - Icemaker

1. Remove screws and the Front Panel.
2. Push the OFF push button switch on the front of the control box, to the OFF position.
3. Remove all ice from the Ice Storage Bin.
4. CLOSE the water supply shutoff valve; or block the float in the Water Reservoir.
5. Disconnect the tube between the Water Reservoir and the bottom of the Freezer Assembly. Drain water from the Reservoir and tube. Reconnect the tube.

### WARNING

**SCOTSMAN Ice Machine Cleaner contains Phosphoric and Hydroxyacetic acids. These compounds are corrosive and may cause burns if swallowed, DO NOT induce vomiting. Give large amounts of water or milk. Call Physician immediately. In case of external contact, flush with water. KEEP OUT OF THE REACH OF CHILDREN.**

6. Prepare cleaning solution: Mix eight ounces of SCOTSMAN Ice Machine Cleaner with two quarts of hot water.
7. Remove the Cover to the Water Reservoir.
8. Slowly pour the cleaning solution into the Water Reservoir.
9. Push the START-RESET push button switch on the front of the Control Box, to the ON position.

10. Continue to slowly pour the cleaning solution into the Water Reservoir, maintain level just below the Reservoir overflow.
11. Continue icemaking, using the cleaning solution, until all the solution is used up and the Water Reservoir is almost empty. DO NOT allow the icemaker to operate with empty Reservoir.
12. Push the OFF push button switch on the front of the Control Box to the OFF position.
13. Wash and rinse the Water Reservoir and wipe dry.
14. OPEN the water supply shutoff valve, or remove the block from the float in the Water Reservoir.
15. Remove ice discharge chute and cover from inside ice maker.
16. Thoroughly clean inside and outside of chute and cover with nylon brush or disposable wipe.
17. To replace chute and cover, reverse removal procedure.
18. Push the START-RESET push button switch on the front of the Control Box to the ON position.
19. Continue icemaking for at least 15 minutes to flush out any cleaning solution. Check ice for acid taste — continue icemaking until ice tastes sweet.
20. Push the OFF push button switch on the front of the Control Box to the OFF position.

### CAUTION

**DO NOT use ice produced from the cleaning solution. Be sure non remains in the bin.**

21. Remove all ice from the Ice Storage Bin.
22. Add hot water to the Ice Storage Bin and thoroughly wash and rinse all surfaces within the Bin.
23. Clean and sanitize the Ice Storage Bin each week.
24. Replace cover and cabinet panel. Push the START—RESET push button switch on the front of the Control Box to the ON position to resume automatic icemaking process.