

TABLE OF CONTENTS

Forward .....	1
Table of Contents .....	2
Photograph .....	3
Specifications and Dimension .....	4
Description .....	5
Installation Instructions .....	6
Installation Limitations .....	7-8
Installation Practices .....	9
Starting the Machine .....	10
Refrigerant Charge .....	10
Final Check List .....	10
Refrigeration Cycle .....	11
Water Schematic .....	12
Ice Discharge Tube and Bin Thermostat Installation .....	13
Wiring Diagram — Air Cooled .....	14
Wiring Diagram — Water Cooled .....	15
Service Analysis .....	16-17
Maintenance Instructions .....	18
SERVICE:	
Gear Motor .....	19
Freezer Assembly .....	19
Freezer Worm Shaft .....	19
Freezer Assembly Top Bearing .....	20
Freezer Assembly Bottom Bearing & Water Seal .....	20
Bin Thermostat .....	20
Contactor .....	20
Head Pressure Control (Water Cooled) .....	21
Water Regulating Valve (Water Cooled Models) .....	21
Water Reservoir .....	21
PARTS BREAKDOWN:	
Chassis Assembly — Air Cooled .....	22
Chassis Assembly — Water Cooled .....	23
Freezer Assembly .....	24
Gear Motor Assembly .....	25
Spout Safety Switch .....	26
Compressor Assembly .....	27
Control Box Assembly .....	28
Reservoir Assembly .....	29
Cabinet Assembly .....	30

**THIS PAGE  
INTENTIONALLY  
LEFT BLANK**

**THIS PAGE  
INTENTIONALLY  
LEFT BLANK**



# MODULAR FLAKER

## MF4

## SERIES

## Continuous Flow

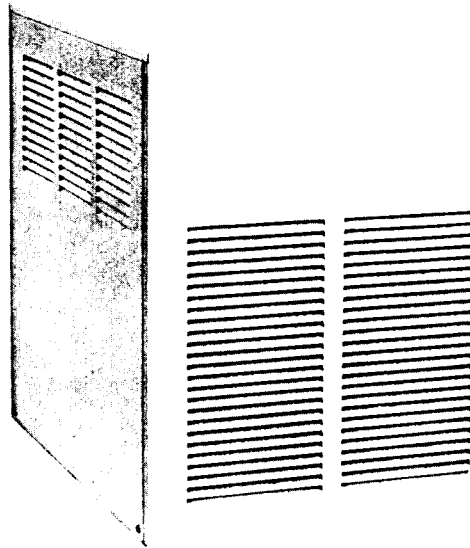

### ice making capacity

Daily Ice Capacity is directly related to condenser air inlet temperature, water temperature, and age of machine.

NOTE: To keep your SCOTSMAN MODULAR FLAKER performing at it's maximum capacity, it is necessary to perform periodic maintenance as outlined on page 18 of this manual.



# SCOTSMAN

MF4-C  
Page 4

## MF4 SERIES

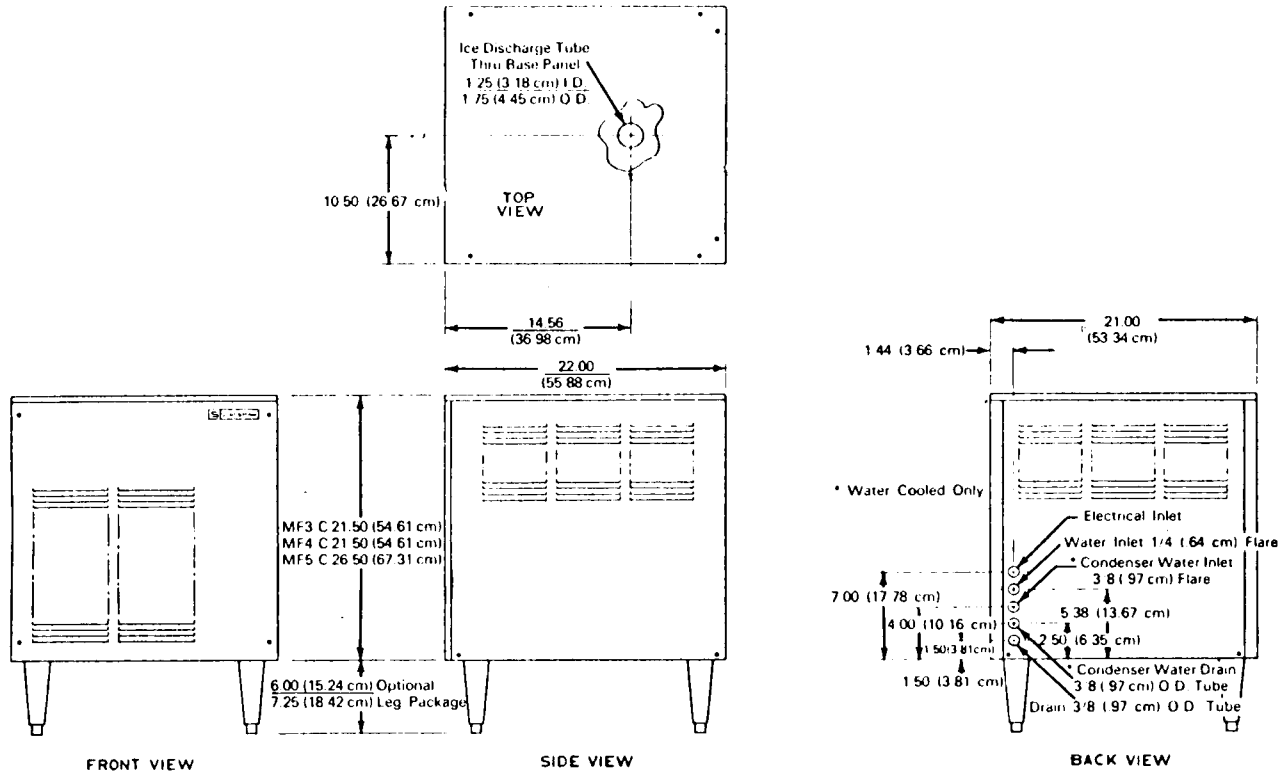

Note: 4" Minimum Air Ventilation on Unit Sides  
6" Minimum Clearance for Utility Connections on Unit Back

### SPECIFICATIONS:

Model	Condensing Unit	Compressor Horsepower	Finish (P. painted) (SS Stainless Steel)	Shipping Weight (lbs.)
MF4AE	Air	3/4	P	208
MF4AS	Air	3/4	SS	208
MF4WE	Water	3/4	P	196
MF4WS	Water	3/4	SS	196

Basic Electricals	Minimum Wire Sizes (w-wire) (g-gauge)	Total Amperages
Air Cooled 115/60/1	2w 12g	14.8
Water Cooled 115/60/1	2w 12g	13.6

Specifications subject to change without notice.

## **DESCRIPTION**

SCOTMAN modular Flakers are designed for restaurants, super markets, soda sountains, hospitals, bakeries, fish markets, poultry stores, packing plants, etc. It is the finest Ice Maker on the market today. It will work 24 hours a day for you, or only as needed. It produces the highest quality ice available at any price.

SCOTSMAN Modular Flakers are easily installed requiring only standard water, drain and electrical connections.

**ATTRACTIVE COMPACT CABINET.** Sandlewood or stainless steel removable panels makes for easy access to mechanical parts.

**SEALED REFRIGERATION SYSTEM.** Provides quiet, effecient operation of the machine. Compressor motor is internally spring mounted for quiet operation. Compressor motor is covered by a full 5-Year Limited Warranty.

**HOW IT WORKS.** An exclusive patented ice-making system, wherein water in the constant level float reservoir is fed to the bottom end of the freezing cylinder and turns to ice on the inside of this cylinder. Ice from the refrigerated walls of this cylinder is extruded past the ice breaker at the top of the cylinder through a side opening by means of a stainless steel auger driven by a gearmotor drive.

Model No. MF-4 is a continuous flow type machine, and is manually started by an OFF and ON switch located inside the cabinet. Since the MF-4 does not have its own attached bin, it is necessary to use an auxillary bin such as the Model SB-500 SCOTSMAN Super Bin for storage. A bin thermostat is mounted in each continuous flow type machine for the purpose of mounting control bulb from machine to bin.

## INSTALLATION INSTRUCTIONS

The following installation instructions were written for use by an authorized tradesman only, not the user or customer. We suggest you call your local authorized Scotsman Service Agency for hook-up, start-up, and check out. He's listed under "Ice Making Machinery & Equipment" in your telephone book, yellow pages.

1. Select unit location prior to hook up of water drain and electrical in accordance with local and national codes. Minimum room temperatures is 50° Fahrenheit, maximum room temperature 100° Fahrenheit. On air cooled models, select well ventilated location.
2. Install bin for use with modular flaker in its permanent location following instructions included with the storage bin.
- \*3. Level bin with adjustable legs and wipe storage bin liner clean with damp cloth.
4. After uncrating modular flaker, remove front, side and top panels and inspect for any concealed damage. Notify carrier of any concealed damage claims.
5. Before placing flaker unit on bin, holes must be provided thru bin top to allow passage of ice discharge tube and bin thermostat control tube into bin.
6. Remove rubber grommets from miscellaneous parts package and insert into place. A good seal must be made between grommets from miscellaneous parts package and insert into place. A good seal must be made between grommet and base panel and between grommet and inner bin. See page 13 drawing.
7. The flaker unit may now be placed on the bin. Insure that the holes in the base panel line up with the holes in the bin top.
8. Install ice discharge tube assembly, taped to freezer body, through sealing pad and base and attach to spout. See page 13.
9. Attach bulb holder to underside of storage bin as shown on page 13. Route bin control tube through smaller grommet then insert tube into tube holder as shown.
10. Check motor compressor hold down nuts to insure motor compressor rides snug on mounting pads.
11. Remove water strainer from envelope for installation in water supply line feeding unit.
12. Open electrical control box cover and check unit nameplate voltage against building source voltage and make sure they correspond. **CAUTION-** Improper voltage supplied to units will void your parts replacement program.
13. Locate and tear out registration card from front of owners guide and fill out card completely including model and serial numbers as taken from aluminum plate found behind front service panel.

\* Legs are accessory items, order thru Sales Department.

## INSTALLATION LIMITATIONS

### ELECTRICAL

1. Scotsman, like most manufacturers, purchases electrical motors that are rated to operate within 10% variance above or below name plate ratings.
2. Improper voltages applied to Scotsman equipment can cause premature failures and burnouts. Failures of this type are not considered as factory fault or defect.

### AMBIENT

**WARNING** — This machine is not designed for outdoor installations. This machine will not operate when air temperatures are below 50° F. or above 100° F.

This unit was not fabricated nor intended to be installed outdoors.

### WATER

3. Scotsman Ice Systems require 20 pounds flowing water pressure to operate satisfactorily. Pressures lower than 20 pounds or interruptions in the water supply can cause serious mechanical damage to this product.

This machine will not operate when water supply temperatures are below 40° F. or above 100° F.



**INSTALLATION  
ELECTRICAL CONNECTIONS:  
MF4AE-1**

**115 Volts, 60 Hertz, 1 Phase  
30 Amp. Circuit**

12 Gauge wire should be used for electrical hook-up. All Scotsman Modular Flakers require a solid earth ground wire.

Be certain that the Super Flaker is on its own circuit and individually fused. The maximum allowable voltage variation should not exceed 10 per cent of the nameplate rating even under starting conditions. Low voltage can cause erratic operation and may be responsible for serious damage to the overload switch and motor windings.

All external wiring should conform to the National, State and local Electrical Code requirements. Usually an electrical permit and the services of a licensed electrician will be required.

Compressor	3/4 HP	Copelaweld: RSL2-0075-1AA 2 pole, 3500 RPM
	Voltage	115
	Amp. rating F.L.A.	14.0
	Hertz	60
	Phase	Single
Gear Drive Motor	1/4 HP	Queen Products 12.2 R.P.M.
	Voltage	115
	Amp. Rating	4.6
	Hertz	60
	Phase	Single
		Thermally Protected

**WATER SUPPLY:** The recommended water supply line is 1/4 inch O.D. copper tubing for the MF-4. Connect to cold water supply line with regular plumbing fittings, with a shut-off valve installed in an accessible place between supply line and machine. A water strainer must be installed with the unit and mounted with clean-out plug down. Locate the strainer next for double check valves in the supply water line, particularly for water-cooled models.

On air-cooled models the water supply line connects to the 1/4 inch flare fitting on the machine. On water-cooled models connections are made to a 3/8 inch male pipe nipple inside of the machine compartment. Incoming water goes through the water regulating valve first and then to the water-cooled condenser. Observe arrow on water regulating valve. Water supply must be installed to conform with local code. In some cases a licensed plumber and/or a plumbing permit will be required.

**NOTE:** If water supply to unit is to be interrupted for any period of time, the unit must be switched off to prevent damage to freezer mechanism.

**DRAIN:** The recommended drain from the bin is 3/8 inch OD copper tubing. Must be run to an open trapped and vented drain. If drain is a long run, allow 1/4 inch pitch per foot. Drain must be installed to conform with local code. Run separate line for condenser discharge water on water-cooled models.

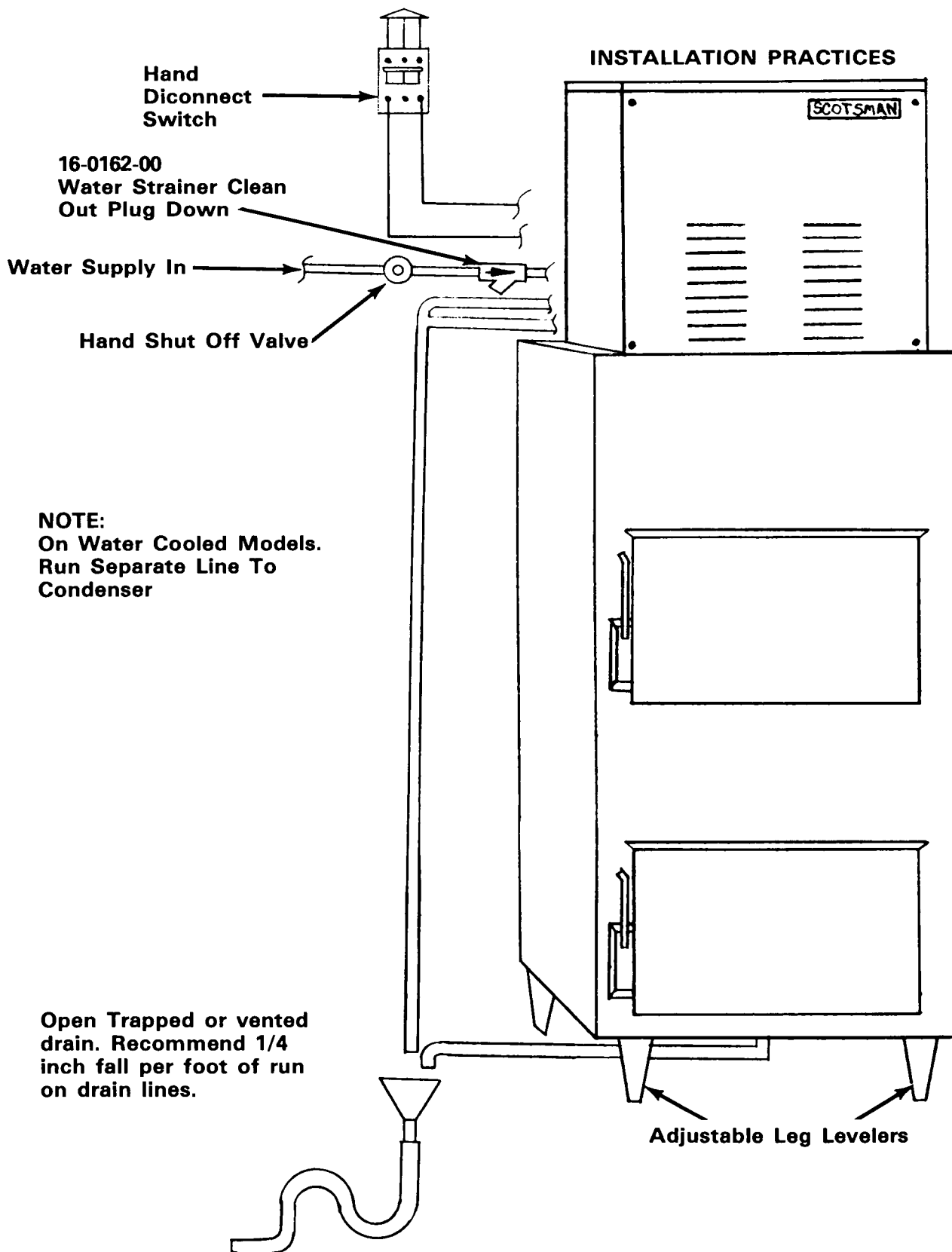

**INSTALLATION PRACTICES**

Hand  
Disconnect  
Switch

16-0162-00  
Water Strainer Clean  
Out Plug Down

Water Supply In

Hand Shut Off Valve

**NOTE:**  
On Water Cooled Models.  
Run Separate Line To  
Condenser

Open Trapped or vented  
drain. Recommend 1/4  
inch fall per foot of run  
on drain lines.

Adjustable Leg Levels

Maximum Ambient Air Temperature Recommended — 100° Fahrenheit  
Minimum Ambient Air Temperature Recommended — 50° Fahrenheit

**NOTE:** Air temperature ranges above or below those listed may cause serious damage to the product.

## STARTING MACHINE

When the machine is placed and inspected as per instructions and all plumbing and electrical connections are completed and tested, turn on the water supply. Be sure the float cover is removed to check on the float operation and water level in the water reservoir. Be sure the water reservoir is filled before starting the machine. Water level should be 1/4 inch below the reservoir overflow.

When this is completed, turn on the manual switch located behind front panel of the cabinet and the machine is in automatic operation. In two to three minutes ice will start dropping off the worm shaft and out the ice chute. Let the machine operate for at least 30 minutes and check for any excess noise other than the normal compressor noise. Test the ice storage control bulb by holding a handful of ice around the bulb until the machine shuts off. One minute should be normal for the control to function. Within minutes after the ice is removed, the bulb will warm up and the machine will automatically start up. The control is factory set and should not be reset until this test is made. Normal setting of this control should be approximately 35 degrees cut-out and 45 degrees cut-in.

Check pressure settings at the time of start-up. On the water-cooled models set the head pressure at 135 PSI. On the air-cooled models the head pressure will vary between 130 and 145 PSI head pressure. The frost line should extend out of the accumulator if properly charged with refrigerant and suction pressure will range between 12 and 14 PSI with 50° F inlet water.

Check the hand reset low pressure control setting. This safety device should be set at approximately 5 PSI below normal operating suction pressure and should cut off in case of interruption in water supply, shortage of refrigerant, low ambient or any other cause of abnormally low suction pressure.

## REFRIGERANT CHARGE

When charging, set at 135 PSI head pressure and charge so that the frost line extends out of the evaporator and into the accumulator after fifteen minutes of operation. Check nameplate for R12 Refrigerant Charge.

<u>Model</u>	<u>Refrigerant Charge</u>
Air-Cooled	26 oz. R-12
Water Cooled	23 oz. R-12

## FINAL CHECK LIST

1. Is the unit level? (**IMPORTANT**)
2. Have all electrical and piping connections been made?
3. Has the voltage been tested and checked against the nameplate rating?
4. Is the water supply valve open and the electric power on?
5. Is the water reservoir filled and shut off?
6. Have unit and bin been wiped clean?
7. Has owner been given this Operating Instruction Booklet, and has he been instructed on how to operate the machine?
8. Have the installation and registration cards been filled out and mailed to the factory?
9. Check all refrigerant and conduit lines to guard against vibration and possible failure.
10. Installed in a well ventilated room where ambient temperatures do not fall below 50° Fahrenheit.
11. Is unit installed with a minimum 4" air space around sides and back?

**WARNING:** THIS MACHINE MUST NOT BE ALLOWED TO OPERATE WHEN THE WATER SUPPLY IS SHUT OFF, OR AT BELOW RECOMMENDED WATER PRESSURE. TURN MASTER SWITCH TO "OFF" POSITION WHEN WATER SUPPLY IS OFF, OR WHEN WATER PRESSURE IS BELOW RECOMMENDED OPERATING PRESSURE.

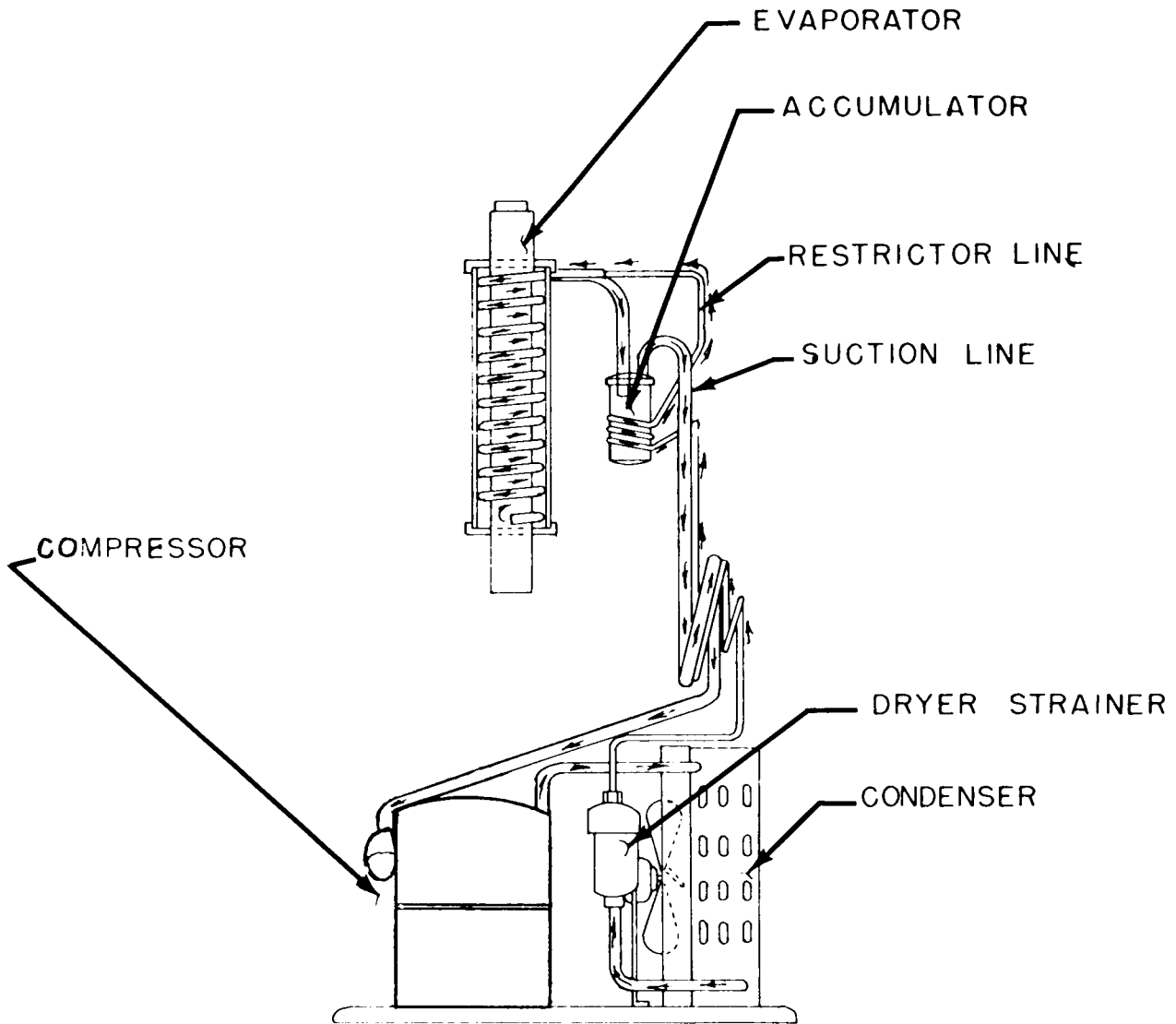

REFRIGERATION CYCLE

WATER SCHEMATIC

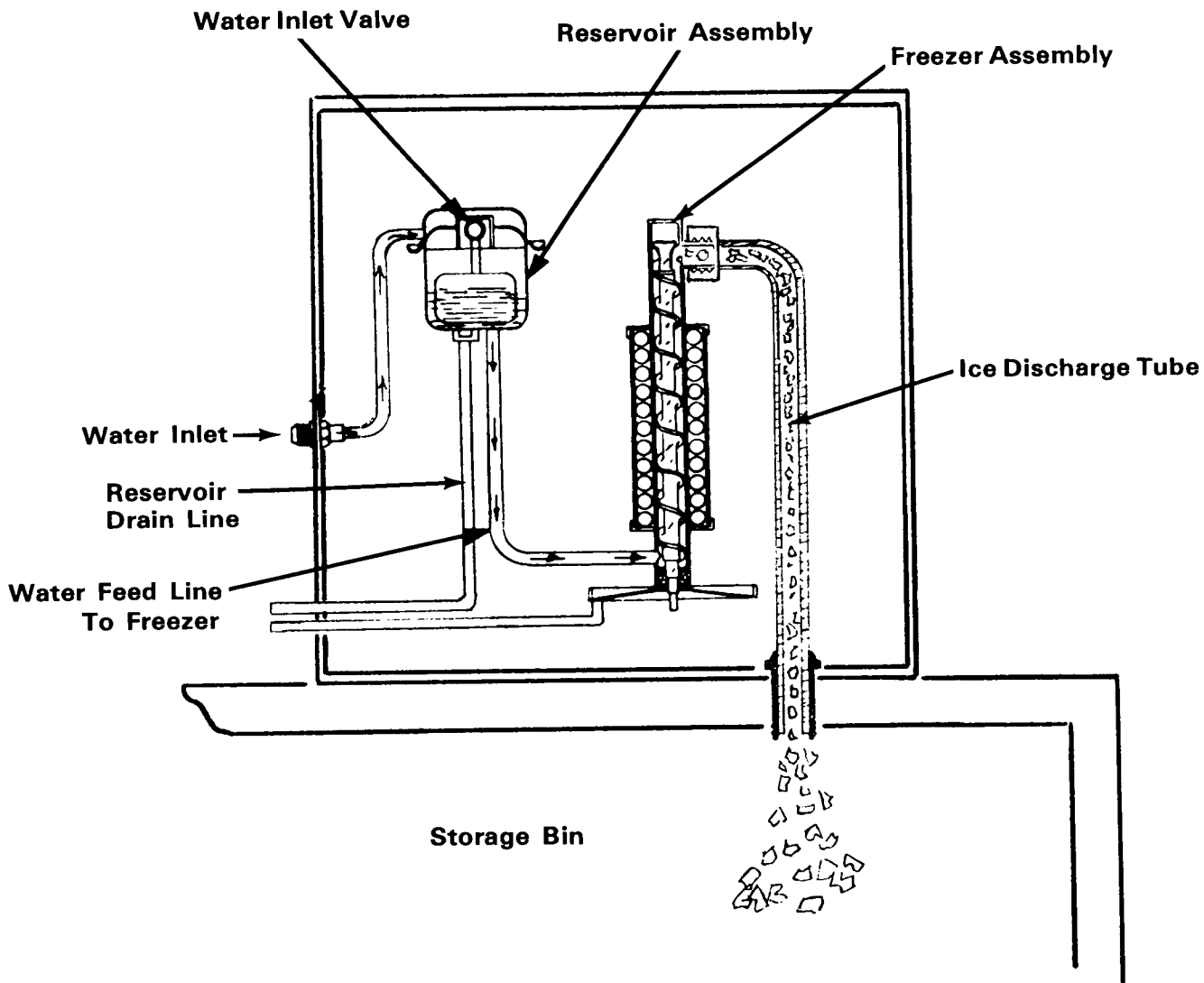

# INSTALLATION INSTRUCTIONS

## MODULAR FLAKER ICE DISCHARGE TUBE

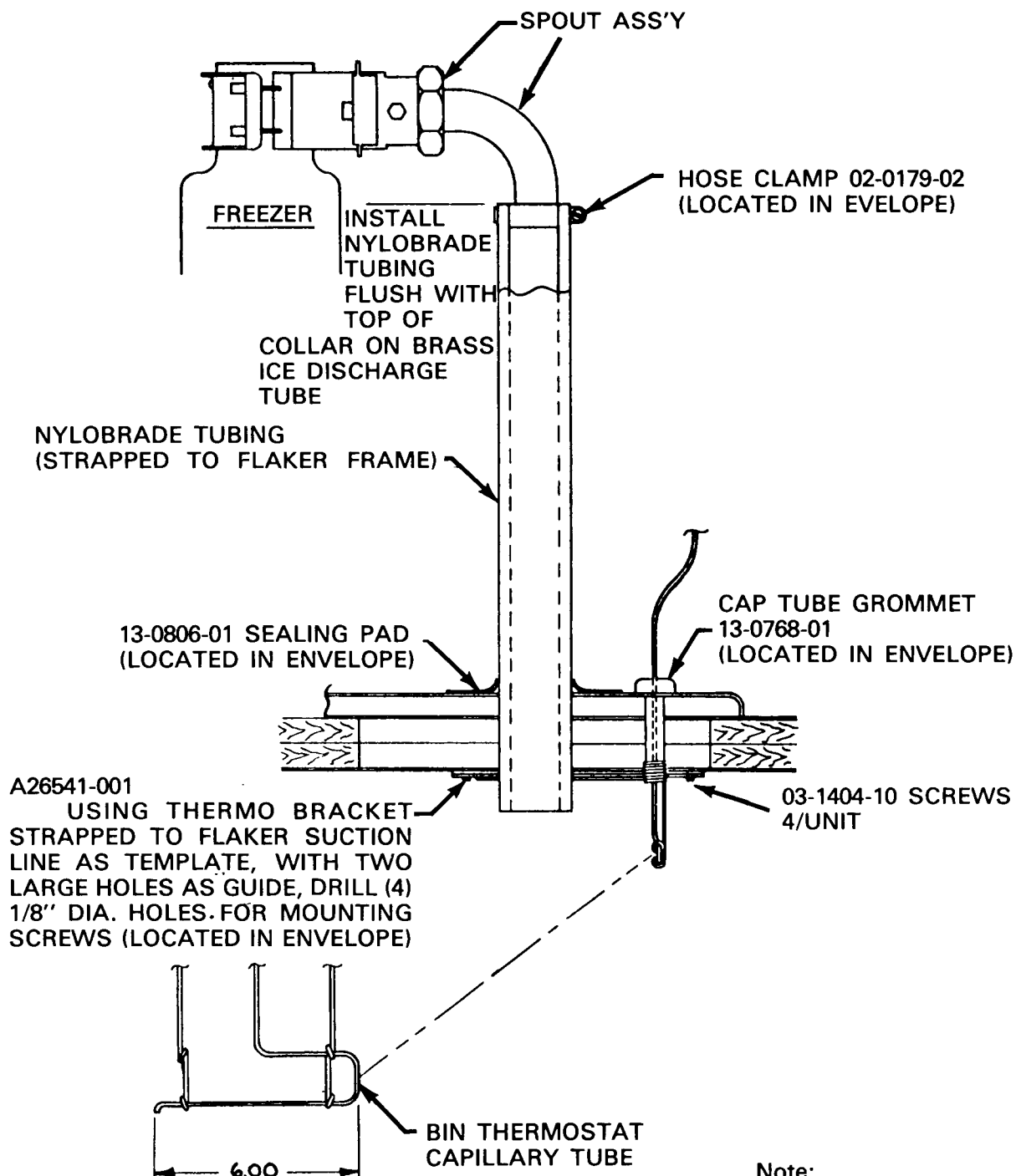

Note:  
See page 26 for  
Spout Ass'y. Breakdown  
(Part No's)

WIRING DIAGRAM

Air Cooled  
115/60/1

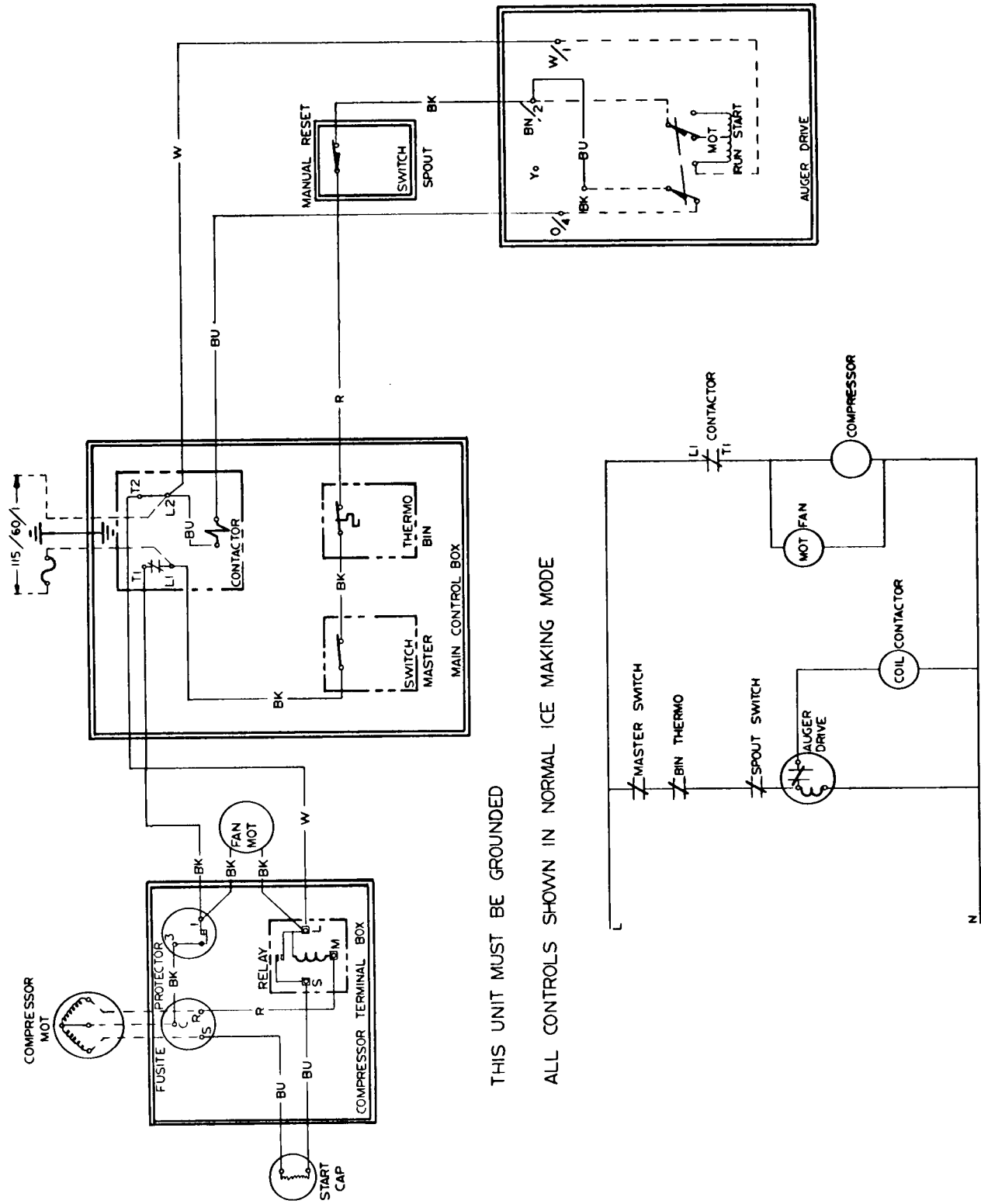

THIS UNIT MUST BE GROUNDED

ALL CONTROLS SHOWN IN NORMAL ICE MAKING MODE

# WIRING DIAGRAM

Water Cooled  
115/60/1

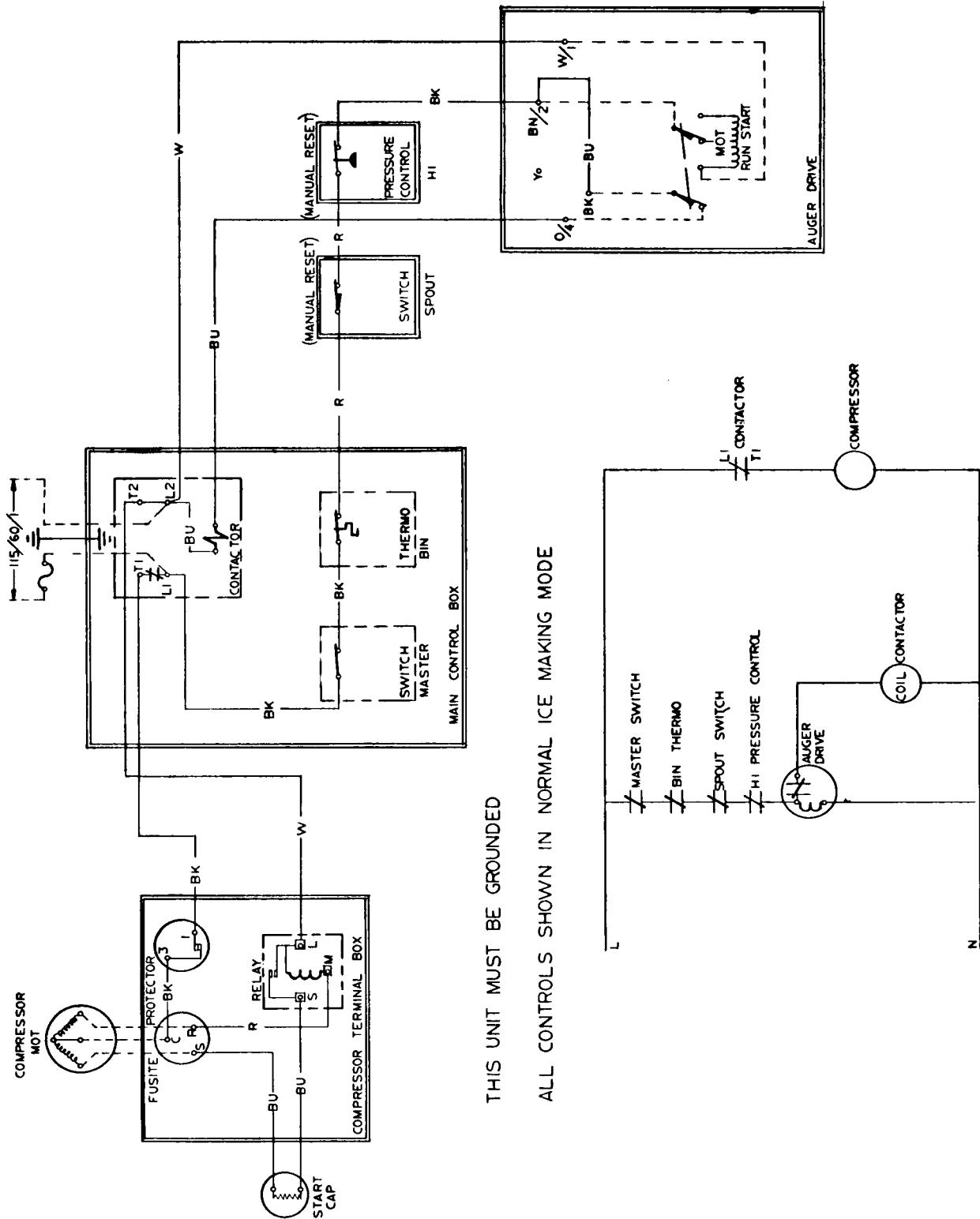

THIS UNIT MUST BE GROUNDED

ALL CONTROLS SHOWN IN NORMAL ICE MAKING MODE



SERVICE ANALYSIS

SYMPTOM	POSSIBLE CAUSE	CORRECTION
Unit will not run	Blown Fuse Thermostat set too high Loose electrical connection Switch in OFF position Inoperative master switch Spout safety switch tripped	Replace fuse and check for cause of blown fuse. Adjust thermostat. 35° cut-out and 45° cut-in. Check wiring. Turn switch to ON. Replace switch. Reset, check actuator and check bin thermostat location.
Compressor cycles intermittently	Low voltage Dirty Condenser Air circulation blocked Inoperative condenser motor Non-condensable gases in system	Check for overloading. Clean. Move unit to correct location. Replace. Purge off.
Making wet ice	Surrounding air temperature Under or over-charge of refrigerant High water level in water reservoir Faulty compressor	Correct or move unit to cooler location. Recharge with the proper amount. Lower to 1/4 inch below overflow pipe. Repair or replace.
Low ice production	Loss of refrigerant, under or over-charge of refrigerant. Dirty or plugged condenser Low water level in water reservoir Partial restriction in capillary tube or drier Inlet water strainer partially plugged. Corroded or stained worm shaft due to water condition.	Check and recharge with proper amount of refrigerant. Clean condenser. Adjust to 1/4 inch below overflow pipe. Moisture in system. Overcharge of oil in System. Remove charge and drier. Replace and recharge system. Remove screen and clean. Remove worm shaft and clean.
Machine runs but makes no ice	Loss or under-charge of refrigerant Drive gearmotor or drive coupling stripped. Water not entering freezing chamber Moisture in system Water seal leaking Water supply to unit off	Check for leaks and recharge Check. Repair and/or replace. Plugged strainer or supply line. Check and clean. Air lock in gravity feed line. Check and remove air lock. Check and remove charge and drier. Replace seal Restore water supply to icemaker.

**SERVICE ANALYSIS**

SYMPTOM	POSSIBLE CAUSE	CORRECTION
Water Leaks	Defective water seal Gravity feed line leaking "O" ring in spout casting leaking. Storage bin drain & connecting fittings leaking. Water level in resevoir too high	Replace Check hose clamps Remove spout casting and install new "O" ring. Check and repair.  Adjust to 1/4 inch below overflow pipe
Excessive noise or Chattering	Mineral or scale deposit on auger and inner freezing chamber walls.  Low suction Intermittent water supply  Water level in resevoir too low. Gearmotor loose on frame Gearmotor end-play or worn bearings.	Remove and manually polish auger, polish inner chamber walls of freezer barrel. For lighter concentrations use Scotsman Ice Machine Cleaner periodically. Add gas to raise suction pressure. Check & clean water strainer. Check gravity feed line for air lock.  Adjust to 1/4 inch below overflow pipe. Tighten.  Repair or replace.
Machine continues to run with full storage bin	Storage bin thermostat not properly set.	Reset or replace. 35° cut-out, 45° cut-in. Check operation with handful of ice.
Gear motor noise	Low on oil	Remove case cover to check for proper oil level. Top of gears should be covered. Use 600 W. oil or equivalent.

## MAINTENANCE INSTRUCTIONS — FLAKERS

THE FOLLOWING MAINTENANCE SHOULD BE SCHEDULED THREE TIMES PER YEAR ON ALL SCOTSMAN FLAKERS. CALL YOUR AUTHORIZED SCOTSMAN SERVICE DEPARTMENT.

1. Check and clean water strainers and float valve. Depress float valve to insure full stream of water.
2. Check water level and machine level, keep water level below overflow, but as high as possible and still not run out of spout opening with machine off. Water droplets come out of spout with ice at all times. Adjust as required.
3. Clean reservoir and interior of freezer using SCOTSMAN Ice Machine Cleaner.

If machine has been cleaned regularly and no problems such as dry ice or chatter are noticed, clean as per the following instructions:

- a. Set main switch to OFF.
- b. Remove all ice from storage bin.
- c. Turn off water supply or block float. Drain reservoir by disconnecting tube between reservoir and freezer. After draining, reconnect tubing.
- d. Set main switch to ON and pour cleaning solution into reservoir. Do not fill above overflow tube.  
Use 6 oz. of Scotsman cleaner and 1- 1/2 qts. hot water.
- e. Continue to make ice on solution until the solution is used up and reservoir is empty.
- f. Set main switch to OFF. Remove overflow tube, wash and rinse reservoir, replace overflow tube, turn water on or remove float block.
- g. Turn MAIN SWITCH to OFF. Add hot water to ice bin, using the melt water, thoroughly wash and rinse all surfaces within the storage bin.
- i. Turn MAIN SWITCH to ON. Replace Service Door. Unit is ready for normal operation.

NOTE: Cleaning requirements vary according to local water conditions. Visual inspection of the auger before and after cleaning will indicate best procedure to be followed in local areas.

4. Check high and low side pressures. On air-cooled models head pressure range between 130 and 145 PSI. Suction pressure should be above 12 PSI and will range up to 15 PSI depending upon the water and ambient temperatures.
5. Check hear motor operation. Normal running temperatures are in the area of 160° Fahrenheit, which is hot to the touch.
6. Check top bearing of freezing tube. Remove retainer ring around edge of stamped brass cap. If moisture is around bearing, wipe up and remove grease. Add new grease. Use Beacon No. 325. Replace cap and retainer ring.
7. Clean air-cooled condenser. Inform customer to clean frequently. Always shut off machine when cleaning.
8. Oil condenser fan motor when possible.
9. Check for refrigerant leaks and proper frostline. Should frost out of accumulator at least one-half way to compressor, and in some areas back to service valve.
10. Check for water leaks. Tighten drain line connections. Run water down bin drain line to make sure it is open.
11. Check quality of ice. Ice should be wet when formed, but will cure rapidly to normal hardness in bin.
12. Check thermostat and pressure cut off in spout. Micro switch cuts off complete unit. Bin thermostat should be set at 10° differential 35° cut out, 45° cut in.

## FREEZER GEARMOTOR

Model MF4 is equipped with a 1/4 horsepower direct drive gearmotor. A speed sensing switch mounted on top of the motor of the gear unit will open and stop the compressor when the R.P.M. of the gearmotor is less than 900. At 1200 R.P.M. it will close, starting the compressor.

In an actual operation any condition that may cause excessively hard ice and overloads within the freezer assembly such as water interruptions, cold ambients, etc. is transmitted to the gearmotor reducing it's speed. When gearmotor slows down to approximately 900 R.P.M. the speed sensing switch opens the electrical circuit to the compressor. The compressor stops and no more ice is produced. Meanwhile the gearmotor continues to run, clearing the overload condition and gradually resumes full speed. At 1200 R.P.M. gearmotor speed sensing switch closes compressor circuit causing the normal icemaking process to begin once more.

Any freeze up possibility is thereby automatically cleared out by the gearmotor.

### TO REPLACE:

1. Remove top, front and side panels.
2. Shut off water supply and electrical power to unit.
3. Remove the electrical leads from the motor to the control box.
4. Remove slip nut attaching ice discharge tube to freezer spout casting.
5. Next remove 3 bolts securing base adapter to gearmotor cover and the 4 bolts holding the gearmotor bracket to the cabinet base.
6. Lift freezer and adapter assembly off gearmotor and pull gearmotor and mounting bracket out of cabinet.

## FREEZER ASSEMBLY

### TO REPLACE:

1. To remove freezer first remove cabinet top, front and side panels.
2. Shut off water supply and disconnect electrical power to unit.
3. Drain reservoir and freezer of water by removing tygon tubing entering base of
4. Remove slip nut attaching ice discharge tube to freezer spout casting.
5. Purge off refrigerant and unsweat suction line. Disconnect capillary line at drier. Cap off all lines so no moisture can enter system.
6. Remove the 3 bolts securing freezer base adapter to top of gearmotor and out.
7. Freezer assembly now can be lifted off gear motor and out of cabinet.
8. To re-install reverse procedure. Refer to section "Specifications" for proper refrigerant charge and to page 10 for Head and Back pressure setting.

## FREEZER WORM SHAFT (AUGER)

### TO REPLACE:

1. Disconnect electrical supply and shut off water to unit.
2. Remove top and front panel of cabinet.
3. Drain reservoir and freezer of water by removing tygon tubing entering base of freezer.
4. Next remove slip nut attaching ice discharge tube to freezer spout casting and insulation covering top of freezer chamber.
5. Remove the 4 bolts attaching the freezer spout casting to the spout bracket and remove spout casting. Also remove bracket by removing the stainless steel screw which secures the bracket to the freezer chamber.
6. By lifting up on the freezer cap pull ring, the complete worm shaft and bearing retainer can be removed from freezer chamber. NOTE: Top half of water seal is attached to the lower end of the worm shaft.

## FREEZER ASSEMBLY TOP BEARING

### TO REPLACE:

1. Follow steps 1 thru 6, freezer worm shaft removal.
2. To remove bearing and retainer from worm shaft, first remove retaining ring in top of bearing retainer.
3. Remove freezer sap and pull ring from bearing retainer.
4. Unscrew cap screw holding shaft to inner race of bearing and pull worm shaft free from bearing and retainer.

When replacing with a new bearing add new grease (Beacon No. 325) to top of bearing.

## FREEZER ASSEMBLY BOTTOM BEARING AND WATER SEAL

### TO REPLACE:

1. To replace, follow steps 1 through 6 under Worm Shaft Removal.
2. Remove 3 bolts holding freezer to mounting adapter.
3. Lift freezer off adapter just high enough to allow bottom bearing and bottom half of water seal to be removed from bottom of freezer tube.
4. Lightly grease bottom half of new water seal and insert face up approximately 1/2" in bottom of freezer tube.
5. Insert bottom bearing in bottom of freezer tube, force approximately 1/8" past bottom tube end. This will allow the positioning ring on adaptor to properly position freezer tube when tightening up the three mounting bolts.
6. After securing mounting bolts, put new top half of water seal on worm shaft the same way as the old seal was removed. Then reassembling, put a small amount of Vaseline on shaft end. This will allow shaft to slide smoothly through rubber bottom half of water seal without tearing it.
7. Carefully insert worm shaft assembly in freezer tube and into spline coupling on bottom.
8. Replace spout casting, screws, insulation pieces and unit is ready to resume operation.

## BIN THERMOSTAT

Thermostat control body is located in electrical control box. The thermostat sensing tube is threaded into the ice storage bin where it automatically stops the icemaker when ice bin fills to sensing tube level and restarts icemaker when ice is removed. Factory settings are 35° cut out, 45° cut in.

Altitude correction begins at 2,000 feet, cut in and cut out screws should be adjusted equally, not more than 1/4 turn at a time.

**IMPORTANT** — Refer to page 13 for proper location of bin control capillary.

### TO REPLACE:

1. Disconnect electrical supply.
2. Remove bin thermostat capillary tube from bin location.
3. Remove front panel and control box cover.
4. Disconnect two spade type electrical leads.
5. Loosen two screws in control mounting bracket.
6. Replace with new control and reassemble in reverse of above.
7. **CAUTION:** Always check new control power element charge before installation to assure receiving an operative control. A handful of ice on bulb will register on audible 'click' at cut off.

## CONTACTOR

The electrical contactor is used to carry the compressor line current. It is wired so that any of the controls in the pilot circuit such as the bin thermostat, low and high pressure controls, etc. will cause the contactor holding coil to be de-energized when the control contact open, thereby, breaking the circuit to the compressor through the contactor points.

### **WATER REGULATING VALVE (Water Cooled Models Only)**

The Water Regulating Valve is designed to maintain a constant head pressure by regulating the amount of incoming water flow through the water cooled condenser. This valve is operated by high side pressure and may be adjusted by the adjusting screw on top of the valve to raise or lower the operating head

#### **TO REPLACE:**

1. Shut off water supply to machine and disconnect electrical power.
2. Disconnect old valve from water supply line and install new valve.  
NOTE: Be sure arrow on side of valve points in direction of water flow.
3. Purge off refrigerant and disconnect valve capillary line from high side fitting and immediately attach capillary from new valve.
4. Recharge system. Refer to page 10 for proper refrigerant charge and head and back pressure settings.

### **WATER RESERVOIR**

A water level is maintained in the water reservoir by a float operated valve. Water is piped from the water reservoir to the freezing chamber by a gravity feed line maintaining an equal water level.

The water reservoir is equipped with a 2 inch air gap to prevent back siphoning and meet all health codes.

The water level in the water reservoir is adjusted by bending float arm. The water level should be set 1/4 inch below the overflow standpipe.

A water strainer must be installed in the supply line. Use strainer sent with machine.

#### **TO REPLACE:**

1. Remove cabinet top and side panel.
2. Turn off water supply and drain reservoir.
3. Remove 1/4 inch inlet water line.
4. Remove plastic feed line to freezer.
5. Remove wing nut located beneath reservoir.
6. Lift out reservoir.
7. To replace, reverse procedure.

### **HEAD PRESSURE CONTROL (WATER COOLED MODELS)**

The head pressure safety control is factory preset at 250 lb. PSIG. This is a manual reset control, no adjustment. The control is placed in the system as a safety precaution, to terminate power to the unit should loss of water occur to the water cooled condenser.

CHASSIS ASS'Y  
Air Cooled

MF4-C  
Page 22

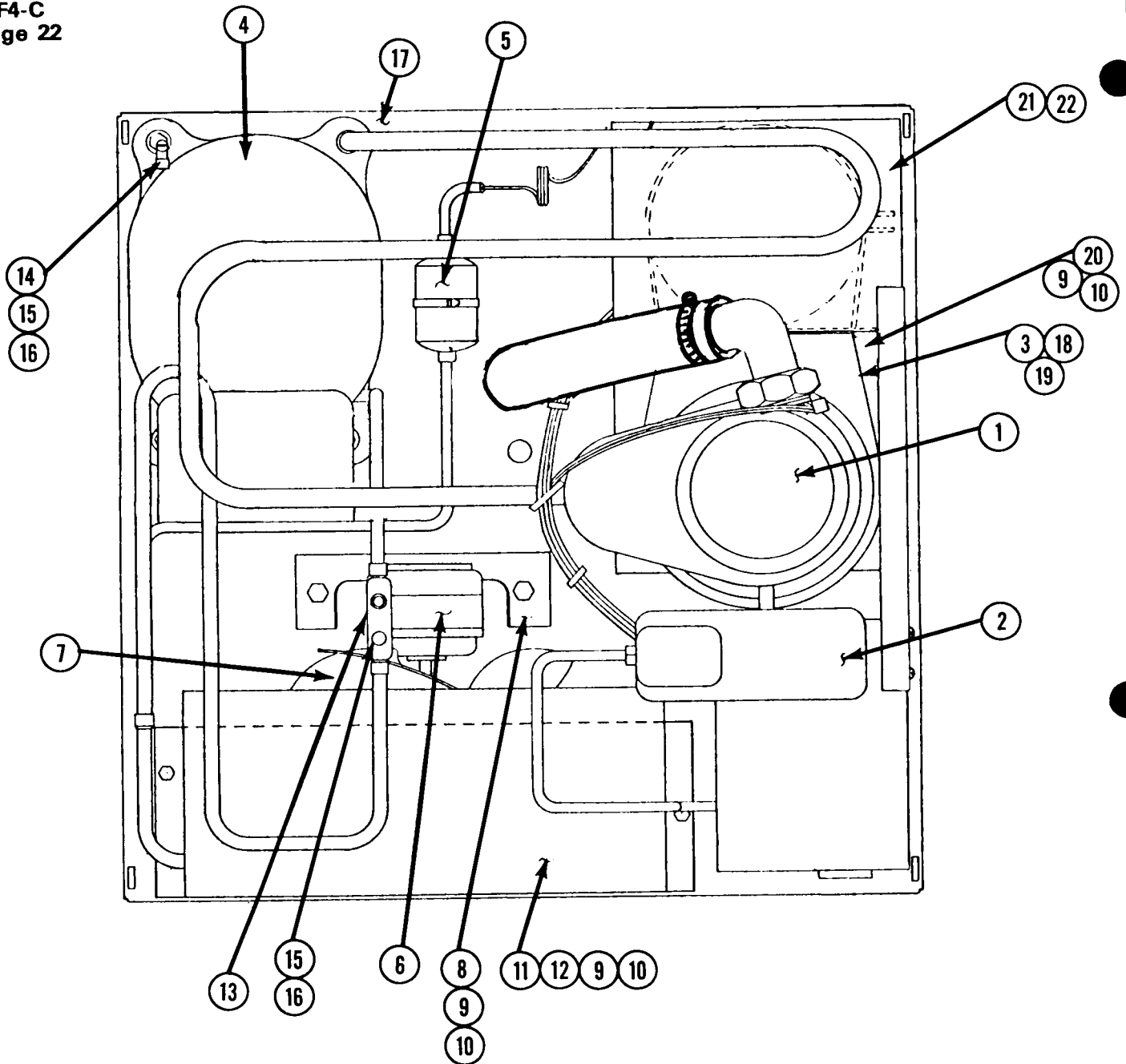

ITEM	PART NO.	DESCRIPTION	ITEM	PART NO.	DESCRIPTION
1.	See Page 24	Freezer Ass'y.	13.	16-0673-18	Process Header
2.	See Page 29	Reservoir	14.	16-0673-15	Process Header
3.	See Page 25	Gear Reducer	15.	16-0560-00	Valve Core
4.	See Page 27	Compressor	16.	16-0563-00	Brass Cap
5.	02-0544-01	Drier	17.	A26596-001	Base Ass'y.
6.	18-0559-01	Fan Motor	18.	03-1405-17	Screw, Plate-Reducer
7.	18-0625-00	Fan Blade	19.	03-1417-12	Lockwasher
8.	A25548-001	Fan Mounting Bracket	20.	A26599-001	Motor Plate
9.	03-1405-03	Screw	21.	A26041-001	Motor Shield
10.	03-1417-09	Washer	22.	A26042-001	Shield Strap
11.	18-0396-01	Condenser			
12.	A23825-001	Shroud			

CHASIS ASS'Y  
Water Cooled

MF4-C  
Page 23

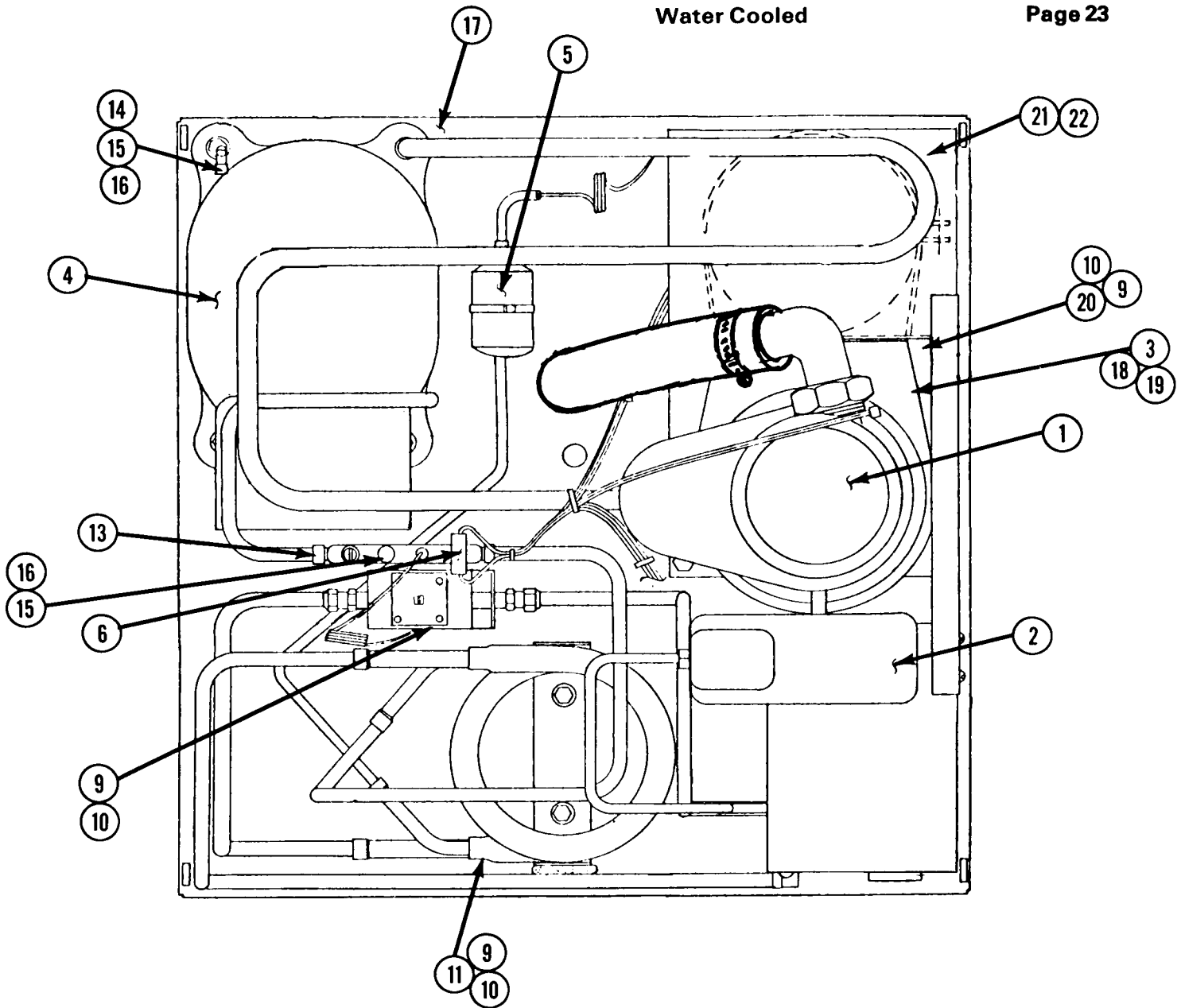

ITEM	PART NO.	DESCRIPTION	ITEM	PART NO.	DESCRIPTION
1.	See Page 24	Freezer Ass'y.	12.		
2.	See Page 29	Reservoir	13.	16-0673-08	Process Header
3.	See Page 25	Gear Reducer	14.	16-0673-15	Process Header
4.	See Page 27	Compressor	15.	16-0560-00	Valve Core
5.	02-0544-01	Drier	16.	16-0563-00	Brass Cap
6.	11-0397-01	Hi-Pressure Switch	17.	A26596-001	Base Ass'y.
7.	11-0198-00	Water Regulator	18.	03-1405-17	Screw, Mtg. Plate-Reducer (3)
8.			19.	03-1417-12	Lockwasher, Plate-Reducer (3)
9.	03-1405-03	Screw	20.	A26599-001	Motor Plate
10.	03-1417-09	Washer	21.	A26041-001	Motor Shield
11.	18-3305-02	Condenser	22.	A26042-001	Shield Strap



# FREEZER ASSEMBLY

MF4-C  
Page 24

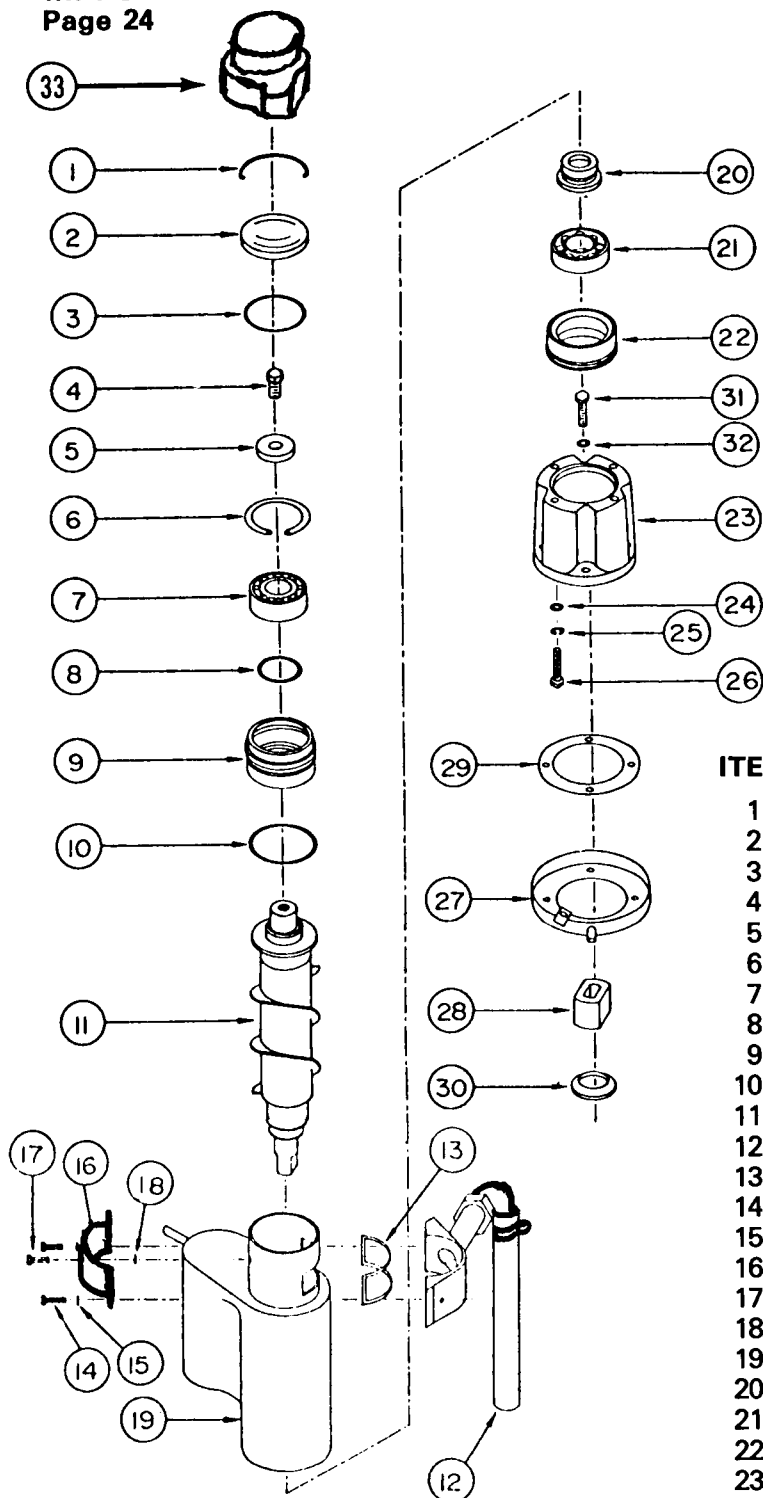

ITEM	DESCRIPTION	PART NO.
1.	A08582-000	Cap Hook
2.	A08581-000	Cap
3.	13-0617-20	"O" Ring
4.	03-1405-36	Cap Screw
5.	A06273-000	Washer
6.	03-1558-04	Retaining Ring
7.	02-0646-00	Bearing
8.	13-1617-15	"O" Ring
9.	A26708-001	Bearing Retainer w/Bearing
10.	13-0617-40	"O" Ring
11.	02-2047-01	Auger
12.	See Page 26	Ice Spout Ass'y.
13.	02-1437-00	Gasket
14.	03-1544-02	Screw (4)
15.	03-1417-07	Lock Washer (4)
16.	A24928-001	Spout Plate
17.	03-1506-01	Screw
18.	03-1409-14	Washer
19.	A26600-001	Freezer Shell w/Heat Exch.
20.	A22569-000	Water Seal
21.	02-0619-00	Lower Bearing
22.	A10591-000	Bearing Retainer
23.	02-1629-00	Adapter
24.	03-1405-41	Screw (4)
25.	03-1410-04	Lock Washer (4)
26.	03-1408-03	Washer (4)
27.	A24156-001	Drip Pan
28.	15-0573-01	Coupling
29.	13-0704-00	Cork Gasket
30.	13-0709-02	Rubber Water Shed
31.	03-1420-03	Screw (4)fl
32.	03-1408-03	Washer (4)
33.	13-0809-01	Rubber Cap

**A24317-021**  
**GEAR MOTOR ASSEMBLY**  
**1/4 HP 115/60/1**  
**OUTPUT SHAFT TURNS**  
**AT 12 R.P.M.**

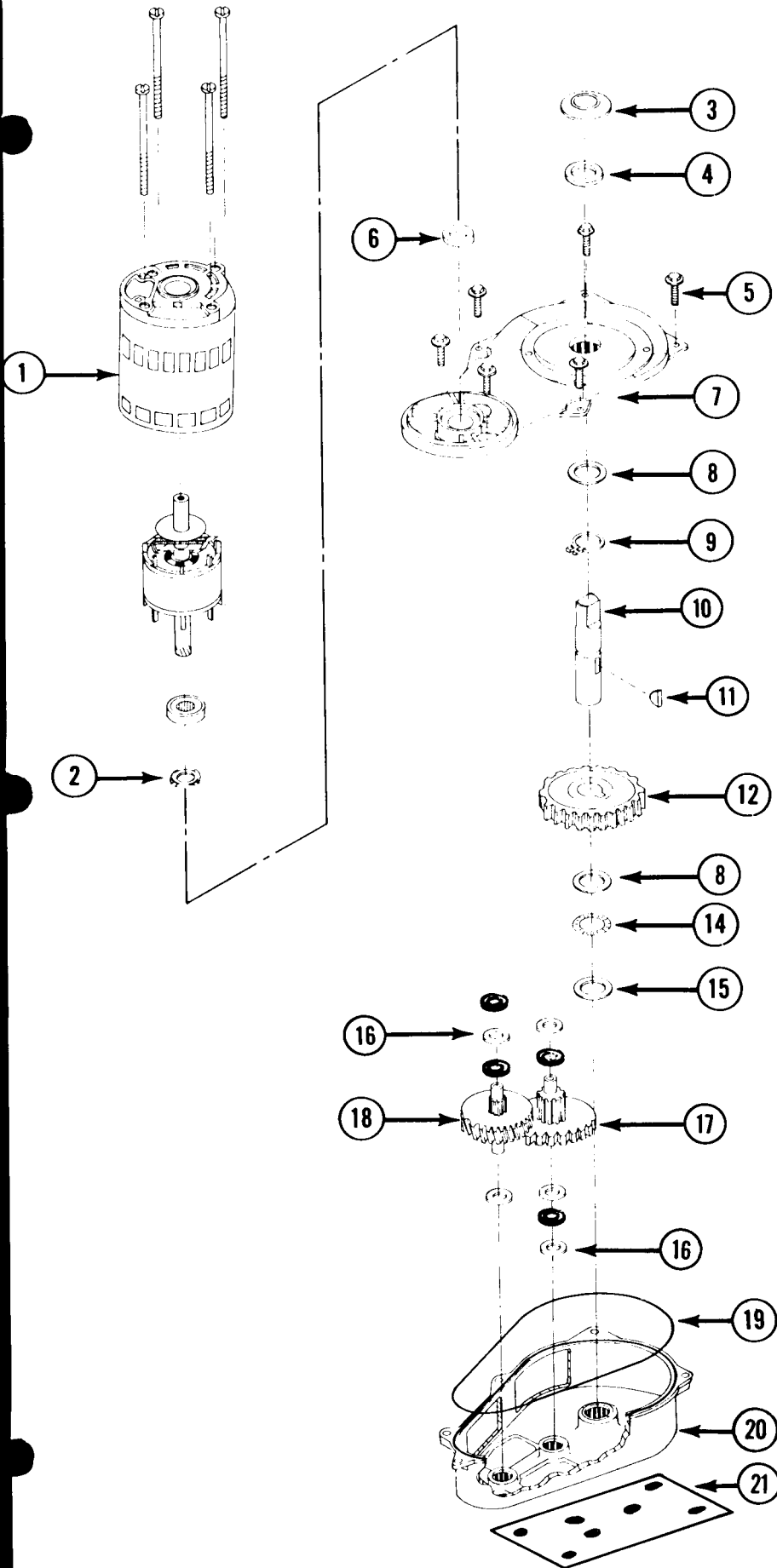

ITEM	PART NO.	DESCRIPTION
1.	A26455-001	Drive Motor 115/60/1
2.	03-1426-00	Spring Washer
3.	13-0709-02	Water Shed
4.	02-1607-00	Oil Seal
5.	03-1251-01	Screws (6 Req'd.)
6.	02-1606-00	Oil Seal
7.	A22200-000	Gear Case Cover Assembly
8.	02-1681-00	Thrust Race
9.	03-1363-00	Retaining Ring
10.	02-1652-00	Output Shaft
11.	03-1364-00	Key
12.	02-1653-00	Output Gear
13.		Bearing
14.	02-1680-00	Thrust Race
15.	02-1679-00	Thrust Race
16.	03-1408-24	Washer (9 Reg'd.)
17.	02-2071-00	Second Gear and Third Pinion Ass'y.
18.	02-2072-00	First Gear and Second Pinion Ass'y.
19.	A26103-001	"O" Ring
20.	A22199-000	Gear Case Ass'y.
21.	A26599-001	Motor Mounting Plate

# SPOUT AND SAFETY SWITCH

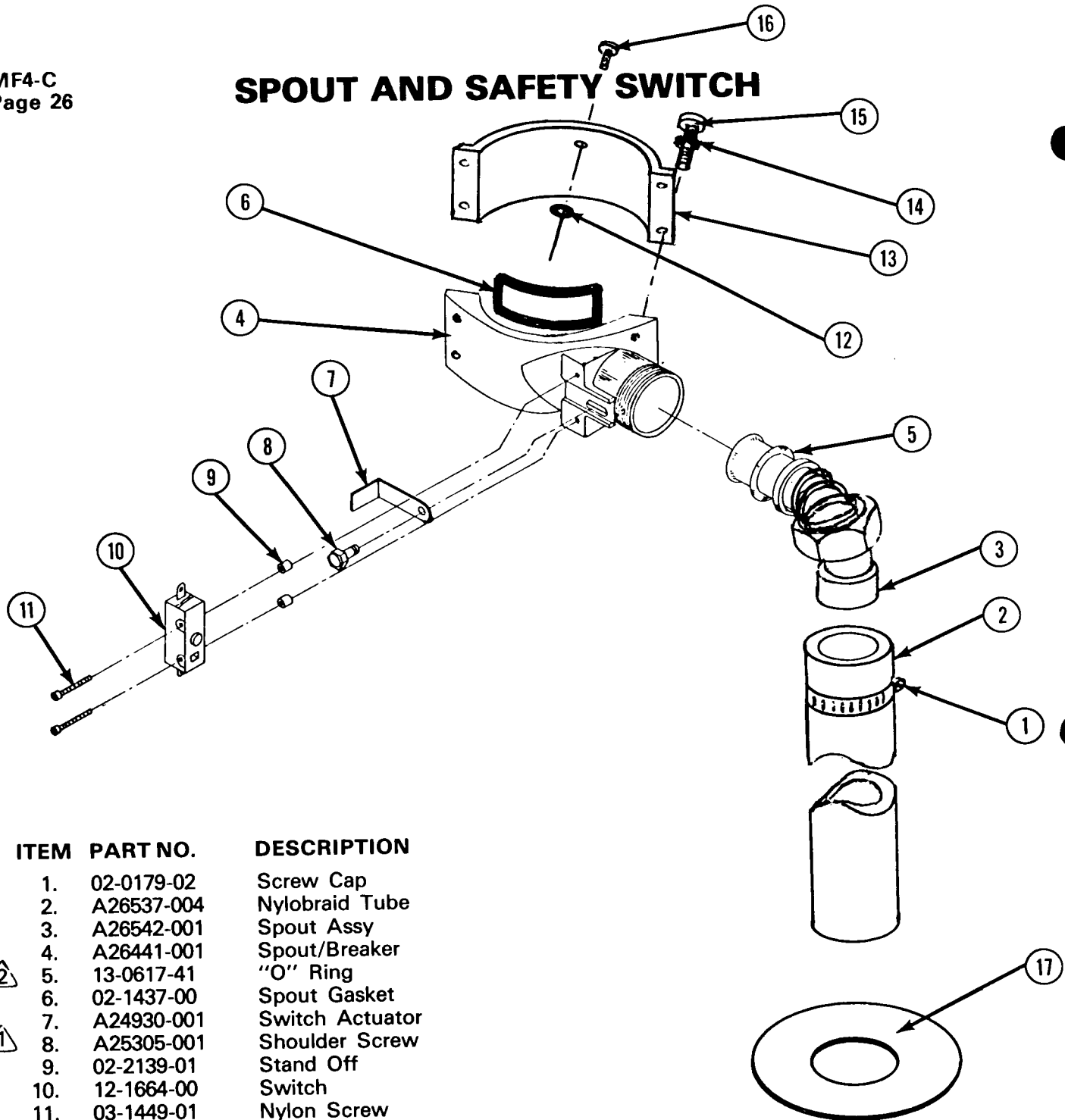

ITEM	PART NO.	DESCRIPTION
	1.	02-0179-02 Screw Cap
	2.	A26537-004 Nylobraid Tube
	3.	A26542-001 Spout Assy
	4.	A26441-001 Spout/Breaker
⚠	5.	13-0617-41 "O" Ring
	6.	02-1437-00 Spout Gasket
	7.	A24930-001 Switch Actuator
⚠	8.	A25305-001 Shoulder Screw
	9.	02-2139-01 Stand Off
	10.	12-1664-00 Switch
	11.	03-1449-01 Nylon Screw
	12.	03-1409-14 Rubber Washer
	13.	A24928-001 Spout Plate
	14.	03-1417-07 Lockwasher (4)
	15.	03-1544-03 Socket Head Screw (4)
	16.	03-1506-01 Screw
	17.	13-0806-01 Sealing Pad

Note:

⚠ Tighten carefully, small thread & brass.

⚠ A light coating of petro-jel req'd. on "O" Ring & Spring

**MOTOR COMPRESSOR**  
**Air and Water**  
**115/60/1 3500 RPM**

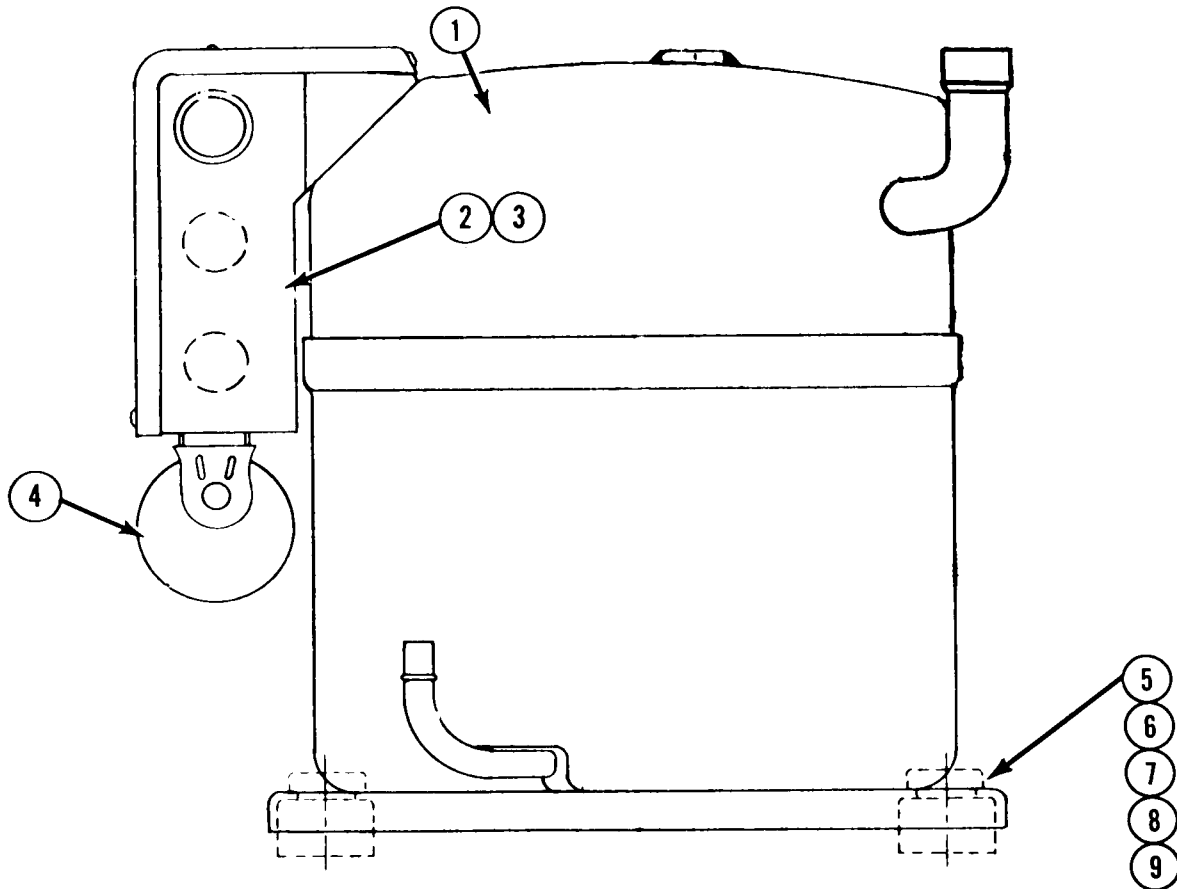

- |    |            |  |
|----|------------|--|
| 1. | 18-3900-01 | Compressor<br>Cope. P.N. RSL2-0075-1AA |
| 2. | 18-2410-00 | Relay<br>Cope. P.N. 040-0098-01        |
| 3. | 18-2400-25 | Overload<br>Cope. P.N. 071-0127-06     |
| 4. | 18-2420-00 | Capacitor<br>Cope. P.N. 014-0008-69    |
| 5. | 18-2200-28 | Mounting Grommet (4)                   |
| 6. | 18-2200-27 | Mounting Sleeve (4)                    |
| 7. | 03-1405-40 | Screw (4)                              |
| 8. | 03-1417-12 | Lockwasher (4)                         |
| 9. | 03-1408-29 | Washer (4)                             |

CONTROL BOX ASS'Y  
Air and Water  
115/60/1

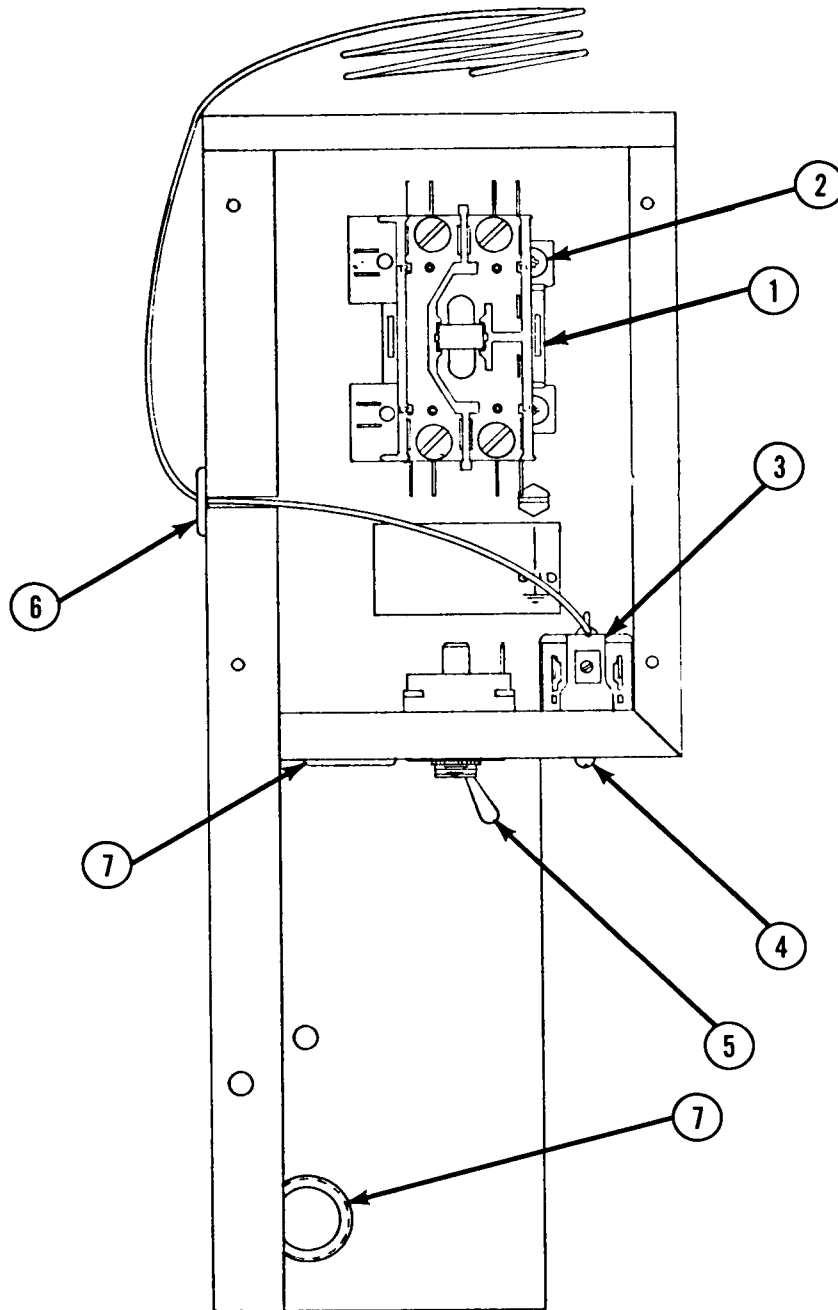

ITEM	PART NO.	DESCRIPTION
1.	12-2037-01	Contactor
2.	03-1403-26	Screw, Contactor (2)
3.	11-0354-00	Bin Control
4.	03-1403-14	Screw, Bin Control (2)
5.	12-0426-01	Master Switch
6.	13-0557-00	Grommet
7.	12-1213-00	Snap Bushing

## RESERVOIR ASSEMBLY

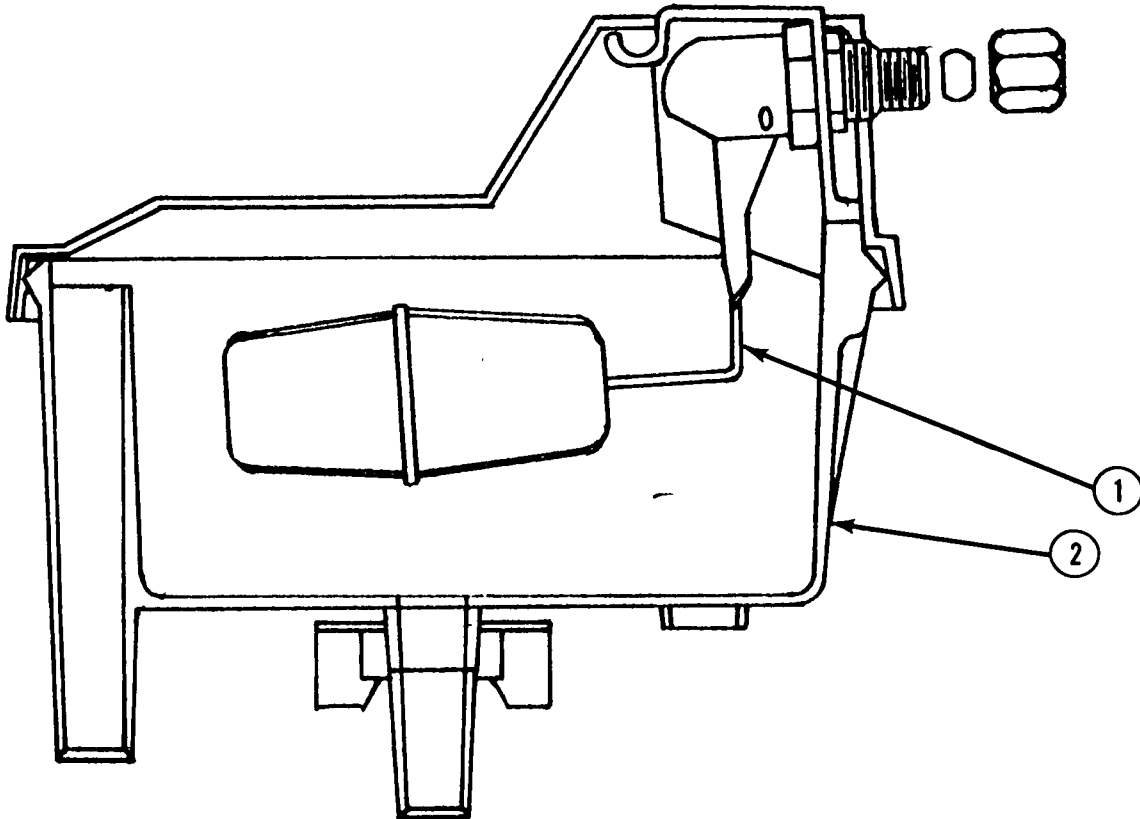

ITEM	PART NO.	DESCRIPTION
1.	02-2217-02	Valve Ass'y.
2.	02-2217-01	Reservoir Complete

CABINET PARTS

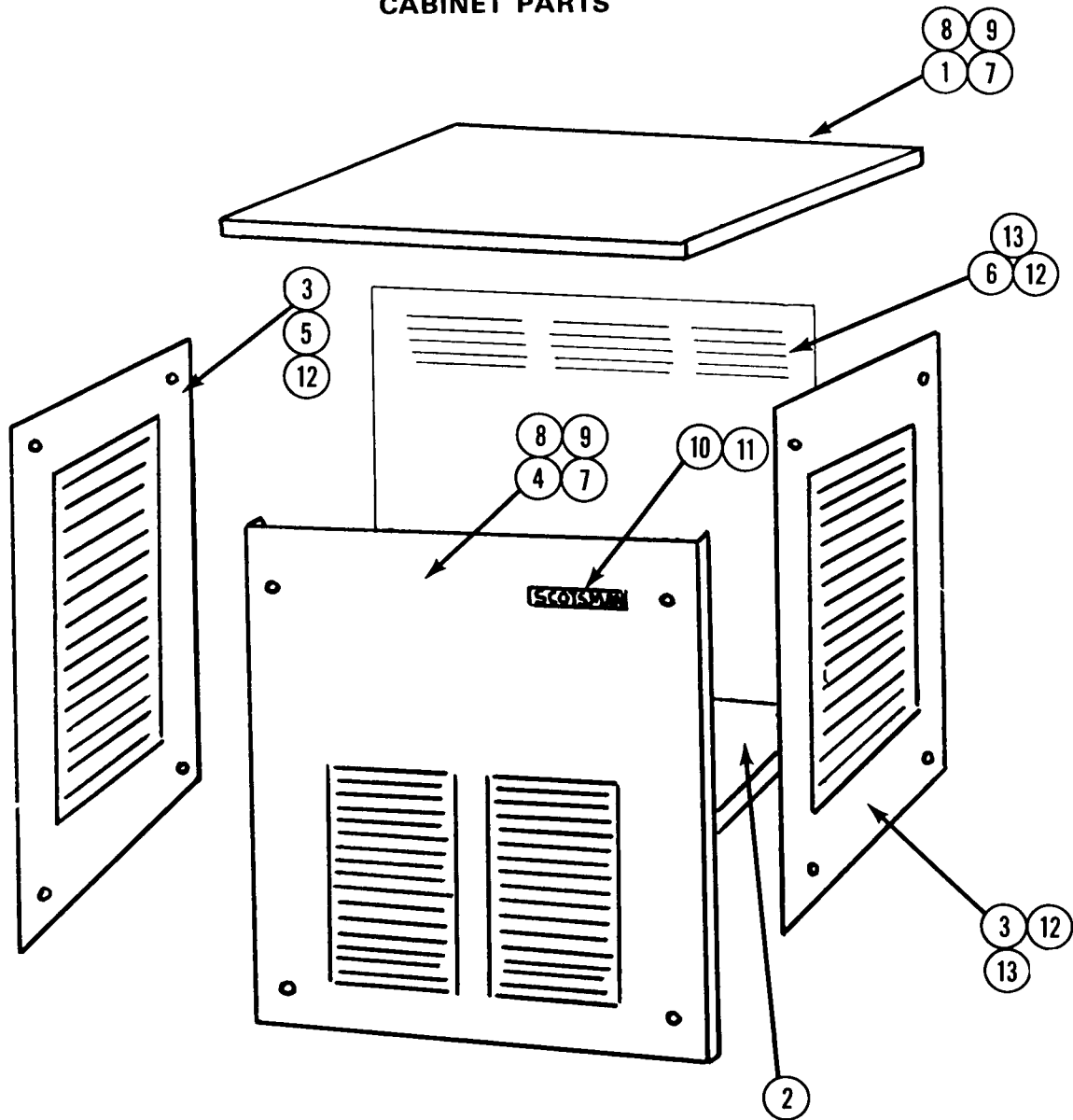

ITEM	DESCRIPTION	ENAMEL	STAINLESS STEEL
1.	Panel Top	A26625-001	A26625-002
2.	Cabinet Base	A26596-001	A26596-001
3.	Panel, Right Side	A26624-001	A26624-002
4.	Panel, Front	A26621-001	A26621-002
5.	Panel, Left Side	A26623-001	A26623-002
6.	Panel, Rear	A26622-001	A26622-002
7.	Screws (10)	03-1419-09	03-1419-09
8.	Lockwashers (10)	03-1417-15	03-1417-15
9.	Speednuts (10)	03-1423-06	03-1423-06
10.	Emblem	15-0580-00	15-0580-00
11.	Speednuts (2)	03-0271-00	03-0271-00
12.	Screw (6)	03-1404-09	03-1404-09
13.	Lockwasher (6)	03-1417-03	03-1417-03
14.	Speednuts (4)	03-1507-01	03-1507-01