

## TABLE OF CONTENTS

Foreward .....	1
Table of Contents .....	2
Photograph and Ice Making Capacity .....	3
Specifications and Dimensions .....	4
Description .....	5
Installation Practices .....	6
Ice Discharge Tube and Bin Thermostat Installation .....	7
Installation Limitations .....	8
Preparation for Installation .....	9
Electric Water Drain Connections .....	10
Starting the Machine - Refrigerant Charge .....	11
Final Check List .....	12
Refrigerant Cycle .....	13
Water Schematic .....	14
Wiring Diagram—Water Cooled .....	15
Wiring Diagram—Air Cooled .....	16
Service Analysis .....	17-18
<b>PARTS BREAKDOWN:</b>	
Chassis Assembly—Air Cooled .....	19
Chassis Assembly—Water Cooled .....	20
Freezer Assembly .....	21
Gear Motor Assembly .....	22
Compressor Assembly .....	23
Control Box Assembly .....	24
Reservoir Assembly .....	25
Cabinet Parts .....	26
Spout and Safety Switch .....	27
Lo Pressure Cycle Control .....	28
<b>SERVICE:</b>	
Gear Motor .....	29
Freezer Assembly .....	29
Freezer Worm Shaft .....	29
Freezer Assembly Top Bearing .....	30
Freezer Assembly Bottom Bearing & Water Seal .....	30
Bin Thermostat .....	30
Head Pressure Control (Water Cooled) .....	31
Water Regulating Valve (Water Cooled Models) .....	31
Water Reservoir .....	31
Maintenance - Cleaning Instructions .....	32
Gear Motor Assembly .....	33
Centrifugal Switch Kit .....	34
Wiring Diagram—Water Cooled .....	35
Wiring Diagram—Air Cooled .....	36

**THIS PAGE  
INTENTIONALLY  
LEFT BLANK**

**THIS PAGE  
INTENTIONALLY  
LEFT BLANK**



# MODULAR FLAKER

## MF3-C

## SERIES

## Continuous Flow

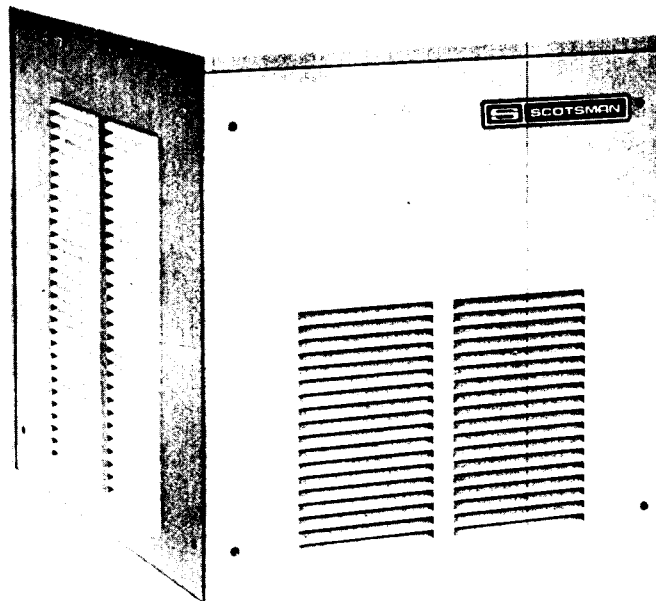

### ice making capacity

Daily Ice capacity is directly related to condenser air inlet temperature, water temperature, and age of machine.

**NOTE:** To keep your SCOTSMAN MODULAR FLAKER performing at it's maximum capacity, it is necessary to perform periodic maintenance as outlined on page 32 of this manual.

# SPECIFICATIONS:

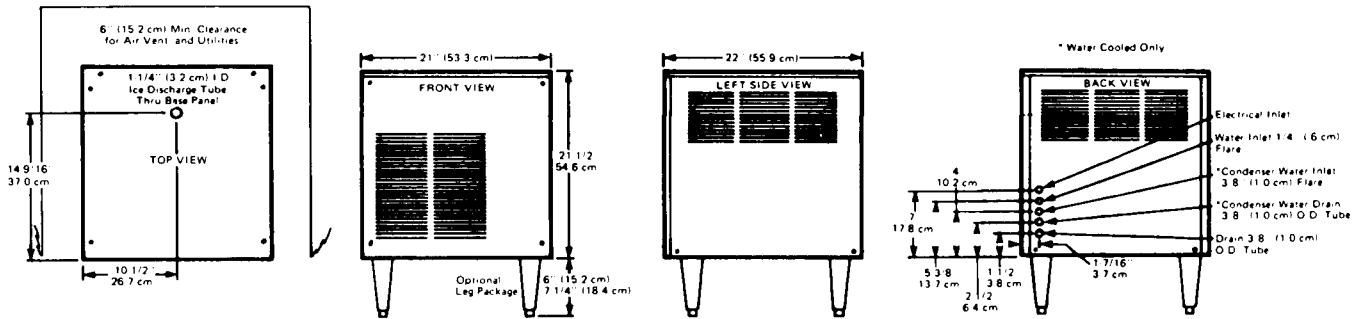

**\*Capacity:** Refer to Ice Making Capacity chart.  
**Storage Bin:** B20, B40, B60, B80, B90, B500, B750 and extensions.  
**Height:** 21 1/2" (54.6 cm)      **Width:** 21" (53.3 cm)  
**Depth:** 22" (55.9 cm)  
**SPKMF3C:** Separate Stainless Steel Panel Kit. Not factory installed.

**OPTIONAL LEG KITS –**  
**KLP2E:** 6" adjustable Black Enamel Legs.  
**KLP2S:** 6" adjustable Nickel Plated Legs.

**IMPORTANT OPERATING REQUIREMENTS:**

**Electrical Voltage:** Machine requires voltage indicated on rating nameplate. Failures caused by improper voltage are not considered factory defects.

**Ambient Temperature:** Machine is not designed for outdoor installation. Machine will not operate when air temperature is below 50° F. or above 100° F.

**Water Pressure & Temperature:** Requires 20 lbs. flowing water pressure, without interruption. Machine will not operate when water supply temperature is below 40° F. or above 100° F.

## TWO YEAR PARTS WARRANTY

### MANUFACTURER'S LIMITED WARRANTY

Scotsman warrants to the original purchaser-user, that any commercial product of its manufacture bearing the name Scotsman will be free from defect in material and/or workmanship, and that if properly installed and serviced in accordance with the User Manual furnished with the product, it will perform adequately under normal use.

This product warranty shall be effective for a period of two years from the date of original installation if such installation is reported on Scotsman's warranty registration form returned to the factory at the time of installation, or for a period of 27 months from date of shipment from the factory if the warranty registration form has not been returned (provided the foregoing warranty periods will be extended for an additional three years as to the motor compressor part) This warranty is applicable only in the United States and Canada.

Scotsman's obligation is limited strictly to replacing without charge, or to repairing, upon return to its factory, transportation charges prepaid, any part or parts that shall be found to be defective in material and/or workmanship during the warranty period. The serial and model numbers and date of original installation of the product must be given. Charges for labor (except labor performed in the Scotsman factory to repair defective parts) are not covered. No part or assembly which has been subject to accident, alteration or misuse, or which is not installed or serviced in accordance with the user manual furnished with the product, or which is from a machine on which the serial number has been altered or removed, shall be covered by this warranty. All decisions regarding defects in material or workmanship or accident, alteration, misuse or improper maintenance or installation shall be made by Scotsman's Service Department and shall be final and binding upon the parties.

Scotsman assumes no liability for incidental or consequential damages of any kind or for any damages resulting in whole or in part from misuse or inadequate maintenance of the product or any part thereof.

THIS WARRANTY IS IN LIEU OF ALL OTHER WARRANTIES OR GUARANTIES OF ANY KIND, EXPRESSED OR IMPLIED, INCLUDING ANY IMPLIED WARRANTY OF MERCHANTABILITY OR FITNESS FOR A PARTICULAR PURPOSE.



### MF3C MACHINE SPECIFICATIONS

Model Number	Condensing Unit	Compressor Horsepower	Finish*	Ship.Wt. lbs./kg.
MF3CAE	Air	1/2	Enamel or	175/79
MF3CWE	Water	1/2	Stainless Steel	175/79

\*Sandalwood baked enamel finish or SPKMF3C Stainless Steel Panel Kit.

Basic Electricals	Max. Oper. Amps	No. of Wires	Min.** Circuit Ampacity	Max. Fuse Size	
Air-Cooled:	115/60/1	16.1	2	18.9	20
	230/60/1	6.3	2	7.4	15
Water-Cooled:	115/60/1	15.2	2	18.0	20
	230/60/1	5.7	2	.8	15

\*\*Use this value to determine minimum wire size required to meet National Electric Code Standards.

We reserve the right to make product improvements at any time. Specifications and design are subject to change without notice.

## DESCRIPTION

SCOTSMAN Modular Flakers are designed for restaurants, super markets, soda fountains, hospitals, bakeries, fish markets, poultry stores, packing plants, etc. It is the finest Ice Maker on the market today. It will work 24 hours a day for you, or only as needed. It produces the highest quality ice available at any price.

SCOTSMAN Modular Flakers are easily installed requiring only standard water, drain and electrical connections.

ATTRACTIVE COMPACT CABINET. Sandlewood or stainless steel removable panels makes for easy access to mechanical parts.

SEALED REFRIGERATION SYSTEM. Provides quiet, efficient operation of the machine. Compressor motor is internally spring mounted for quiet operation. Compressor motor is covered by a 5-Year Warranty.

HOW IT WORKS. An exclusive patented ice-making system, wherein water in the constant level float reservoir is fed to the bottom end of the freezing cylinder and turns to ice on the inside of this cylinder. Ice from the refrigerated walls of this cylinder is extruded past the ice breaker at the top of the cylinder through a side opening by means of a stainless steel auger driven by a gearmotor drive.

Model No. MF-3 is a continuous flow type machine, and is manually started by an OFF and ON switch located inside the cabinet. Since the MF3 does not have its own attached bin, it is necessary to use an auxillary bin such as the MODEL SB-500 SCOTSMAN Bin for ice storage. A bin thermostat is mounted in each continuous flow type machine for the purpose of mounting control bulb from machine to bin.

The MF Series Flakers are also designed for remote type installations, whereby, ice can be transported from the flaker via plastic tubing to a bin located several feet away.

### INSTALLATION PRACTICES

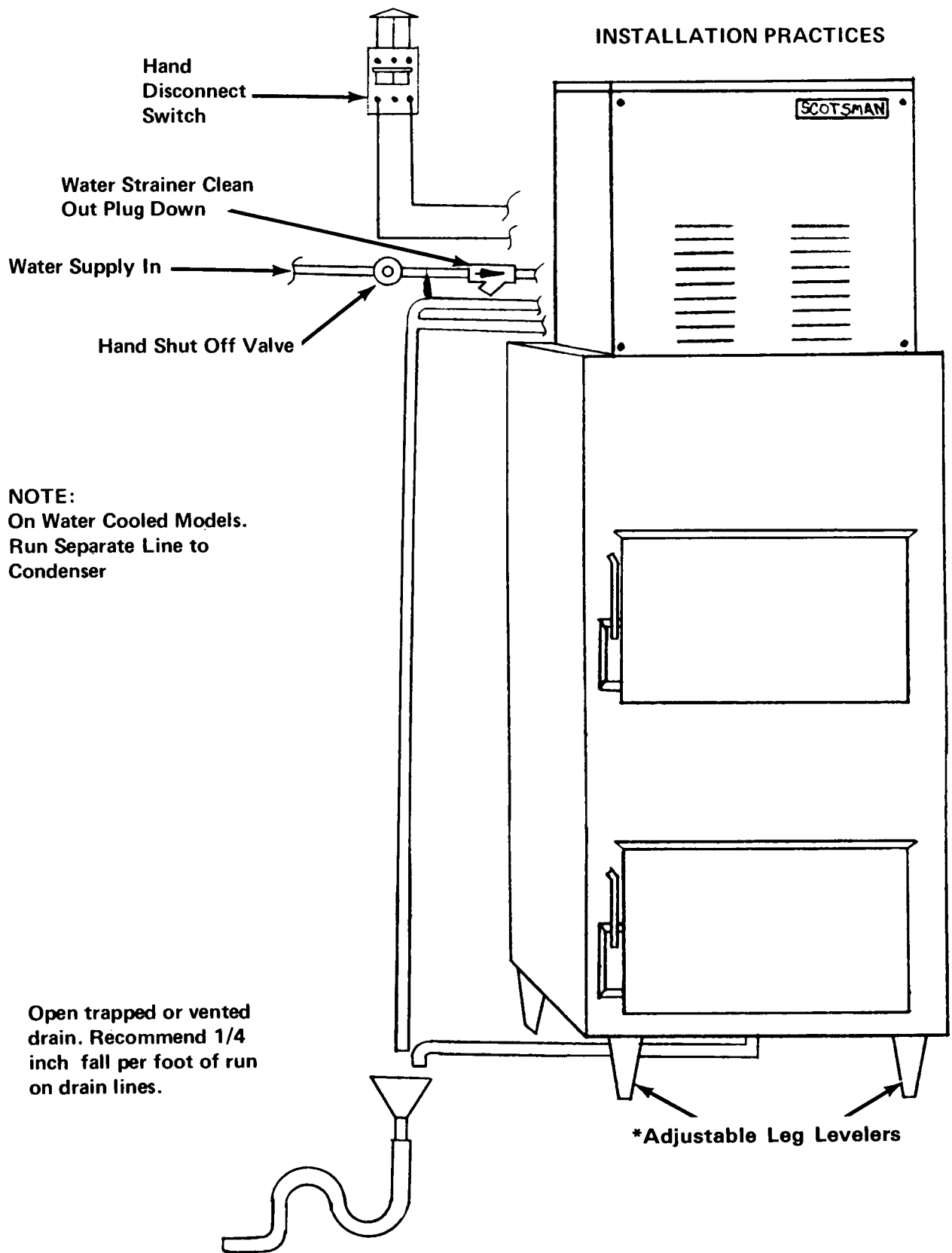

**NOTE:**  
On Water Cooled Models.  
Run Separate Line to  
Condenser

Open trapped or vented  
drain. Recommend 1/4  
inch fall per foot of run  
on drain lines.

\*Adjustable Leg Levelers

\*Bin Legs Optional

# INSTALLATION INSTRUCTIONS

## MODULAR FLAKER ICE DISCHARGE TUBE MF3 SERIES

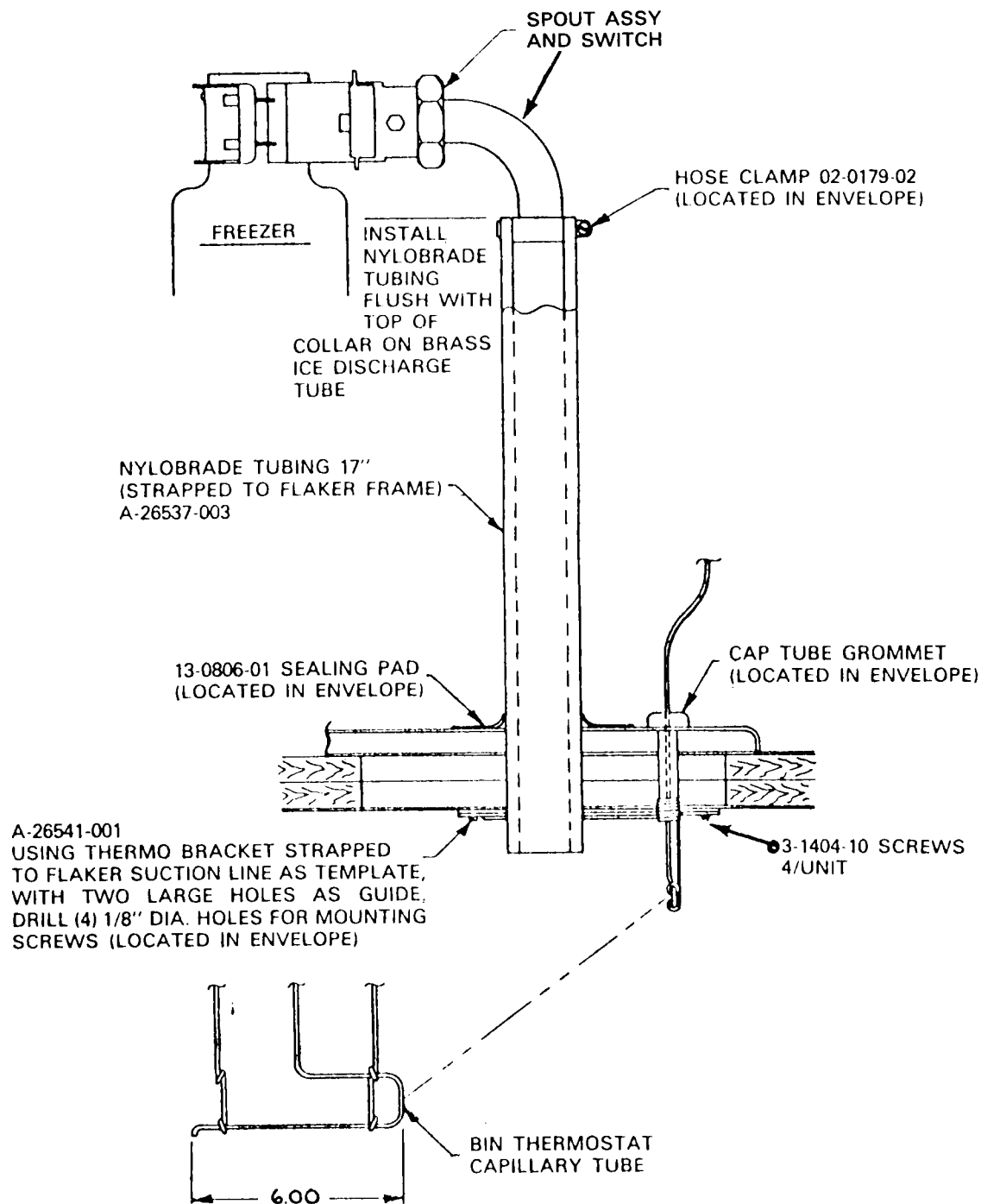



## **INSTALLATION LIMITATIONS**

### **ELECTRICAL**

1. Scotsman purchases electrical motors that are rated to operate within 10% variance above or below nameplate ratings.
2. Improper voltages applied to Scotsman equipment can cause premature failures and burnouts. Failures of this type are not considered as factory fault or defect.

### **AMBIENT**

**WARNING** — This machine is not designed for outdoor installations. This machine will not operate when air temperatures are below 50° F. or above 100° F.

This unit was not fabricated nor intended to be installed outdoors.

### **WATER**

3. Scotsman Ice Systems require 20 pounds flowing water pressure to operate satisfactorily. Pressures lower than 20 pounds or interruptions in the water supply can cause serious mechanical damage to this product.

This machine will not operate when water supply temperatures are below 40° F. or above 100° F.

## **WARNING**

This machine is not designed for outdoor installations or installations where air temperatures are below 50° F or above 100° F and the water temperature is below 40° F or above 100° F. Extended periods of operation at temperatures exceeding these limitations will constitute misuse under the terms of the Scotsman manufacturers limited warranty resulting in a loss of warranty coverage.

1. The following installation instructions were written for use by an authorized tradesman only, not the user or customer. We suggest you call your local authorized Scotsman Service Agency for hook-up, start-up, and check out. He's listed under "Ice Making Machinery & Equipment" in your telephone book, yellow pages.

### SCOTSMAN MODULAR FLAKERS PREPARATION FOR INSTALLATION

1. Select unit location prior to hook up of water drain and electrical in accordance with local and national codes. Minimum room temperatures is 50<sup>o</sup> Fahrenheit, maximum room temperature 100<sup>o</sup> Fahrenheit. On air cooled models, select well ventilated location.
2. Install bin for use with modular flaker in its permanent location following instructions included with the storage bin.
3. Level bin with adjustable legs and wipe storage bin liner clean with damp cloth.
4. After uncrating modular flaker, remove front, side and top panels and inspect for any concealed damage. Notify carrier of any concealed damage claims.
5. Before placing flaker unit on bin, holes in rubber gasket on bin top must be cut to allow passage of ice discharge tube and bin thermostat control tube into bin. This can be done by using holes in bin top as a template.
6. Remove rubber grommet from miscellaneous parts package and insert into place. A good seal must be made between grommet and base panel and between grommet and inner bin. See page 7 cutaway drawing.
7. The flaker unit may now be placed on the bin. Insure that the holes in the base panel line up with the holes in the bin top.
8. Position ice discharge tube assembly, through large grommet in base & attach to spout. See page 7.
9. Attach bulb holder to ice discharge tube in direction shown on page 7. Route bin control tube through smaller grommet then insert tube into tube holder as shown.
10. Thru cabinet top, locate water reservoir. Remove water reservoir cover and check for free action of float ball.
11. Check motor compressor hold down nuts to insure motor compressor rides snug on mounting pads.
12. Remove water strainer from envelope for installation in water supply line feeding unit.
13. Open electrical control box cover and check unit nameplate voltage against building source voltage and make sure they correspond. Caution - Improper voltage supplied to units will void your parts replacement program.
14. Locate and tear out registration card from front of owners guide and fill out card completely including model and serial numbers as taken from aluminum plate found behind front service panel. Forward to Scotsman factory using self mailing card, for your personal registration certificate.

**INSTALLATION**  
**ELECTRICAL CONNECTIONS:**  
**MF3AE-1**  
**115 Volts, 60 Hertz, 1 Phase**  
**20 Amp. Circuit**

Code sized wire should be used for electrical hook-up. All Scotsman Modular Flakers require a solid earth ground wire.

Be certain that the Flaker is on its own circuit and individually fused. The maximum allowable voltage variation should not exceed 10 per cent of the nameplate rating even under starting conditions. Low voltage can cause erratic operation and may be responsible for serious damage to the overload switch and motor windings.

All external wiring should conform to the National, State and local Electrical Code requirements. Usually an electrical permit and the services of a licensed electrician will be required.

**ELECTRICAL INSTALLATION**  
**MF3AE-1C**

Compressor	1/2 HP	Copelaweld: RSF2-0050-1AA-207
		2 pole, 3500 RPM
	Voltage	115
	Amp. rating F.L.A.	10.0
Gear Drive Motor	Hertz	60
	Phase	Single
	1/10 HP	Queen Products
	Voltage	115
	Amp. Rating	4.0
	Hertz	60
	Phase	Single
	Thermally Protected	

**WATER SUPPLY:** The recommended water supply line is 1/4 inch I.D. copper tubing for the MF3. Connect to cold water supply line with regular plumbing fittings, with a shut-off valve installed in an accessible place between supply line and machine. A water strainer must be installed with the unit and mounted with clean-out plug down. Locate the strainer next to the machine with the arrow in the direction of the flow. Most plumbing codes also call for double check valves in the supply water line, particularly for water-cooled models.

On air-cooled models the water supply line connects to the 1/4 inch flare fitting on the machine. On water-cooled models connections are made to a 3/8 inch male pipe nipple inside of the machine compartment. Incoming water goes through the water regulating valve first and then to the water-cooled condenser. Observe arrow on water regulating valve. Water supply must be installed to conform with local code. In some cases a licensed plumber and/or a plumbing permit will be required.

**WARNING:** This machine must not be allowed to operate when the water supply is shut off, or at below recommended water pressure. Turn master switch to 'OFF' position when water supply is off, or when water pressure is below recommended operating pressure.

**DRAIN:** The recommended drain from the bin is 1/2" N.P.T. pipe nipple. Must be run to an open trapped and vented drain. If drain is a long run, allow 1/4 inch pitch per foot. Drain must be installed to conform with local code. Run separate line for condenser discharge water on water-cooled models.

**STARTING THE MACHINE:**

When the machine is placed and inspected as per instructions and all plumbing and electrical connections are completed and tested, turn on the water supply. Be sure the float cover is removed to check on the float operation and water level in the water reservoir. Be sure the water reservoir is filled before starting the machine. Water level should be 1/4 inch below the reservoir overflow.

When this is completed, turn on the manual switch located behind front panel of the cabinet and the machine is in automatic operation. In two to three minutes ice will start dropping off the worm shaft and out the ice chute. Let the machine operate for at least 30 minutes and check for any excess noise other than the normal compressor noise. Test the ice storage control bulb by holding a handful of ice around the bulb until the machine shuts off. One minute should be normal for the control to function. Within minutes after the ice is removed, the bulb will warm up and the machine will automatically start up. The control is factory set and should not be reset until this test is made. Normal setting of this control should be approximately 35 degrees cut-out and 45 degrees cut-in.

Check pressure settings at the time of start-up. On the water-cooled models set the head pressure at 135 PSI. On the air-cooled models the head pressure will vary between 130 and 145 PSI head pressure. The frost line should extend out of the accumulator if properly charged with refrigerant and suction pressure will range between 12 and 14 PSI with 50° F inlet water.

**REFRIGERANT CHARGE:**

The below refrigerant charge is approximate. When charging, set at 135 PSI head pressure and charge so that the frost line extends out of the evaporator and into the accumulator after fifteen minutes of operation.

<u>Model</u>	<u>Refrigerant Charge</u>
Air-Cooled	23 oz. R-12
Water Cooled	20 oz. R-12

**WARNING: THIS MACHINE MUST NOT BE ALLOWED TO OPERATE WHEN THE WATER SUPPLY IS SHUT OFF, OR AT BELOW RECOMMENDED WATER PRESSURE. TURN MASTER SWITCH TO "OFF" POSITION WHEN WATER SUPPLY IS OFF, OR WHEN WATER PRESSURE IS BELOW RECOMMENDED OPERATING PRESSURE.**

### FINAL CHECK LIST

1. Is the unit level? (IMPORTANT)
2. Have all electrical and piping connections been made?
3. Has the voltage been tested and checked against the nameplate rating?
4. Is the water supply valve open and the electric power on?
5. Is the water reservoir filled and shut off?
6. Have unit and bin been wiped clean?
7. Has owner been given the Users Manual, and has he been instructed on how to operate the machine?
8. Have the installation and registration cards been filled out? This is the owner's protection.
9. Check all refrigerant and conduit lines to guard against vibration and possible failure.
10. Installed in a well ventilated room where ambient temperatures do not fall below 50° Fahrenheit.
11. Is unit installed with a minimum 4" air space around sides and back?
12. Bin thermostat operation and proper shut off level checked?
13. Drain lines checked and open?

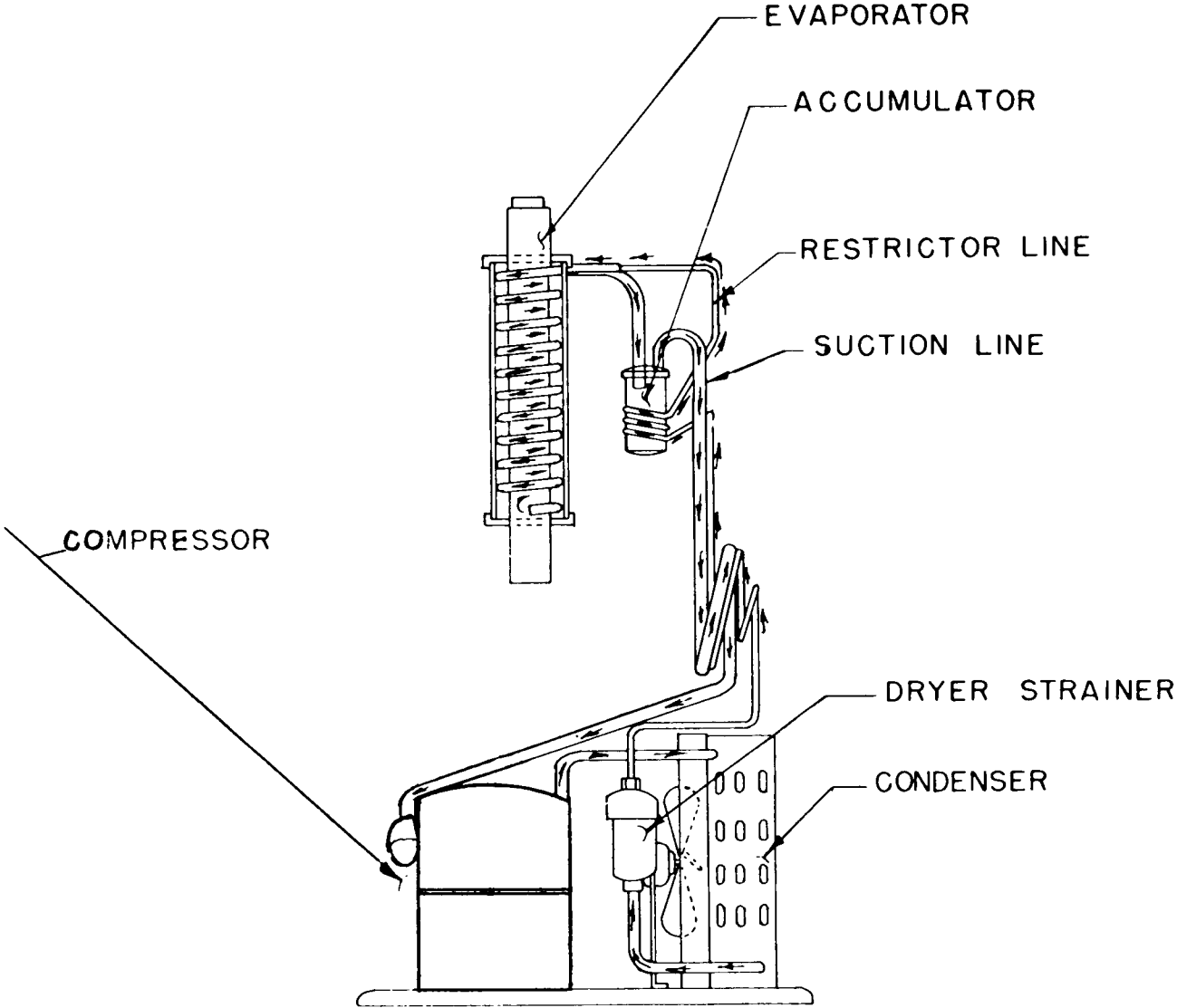

REFRIGERATION CYCLE

WATER SCHEMATIC

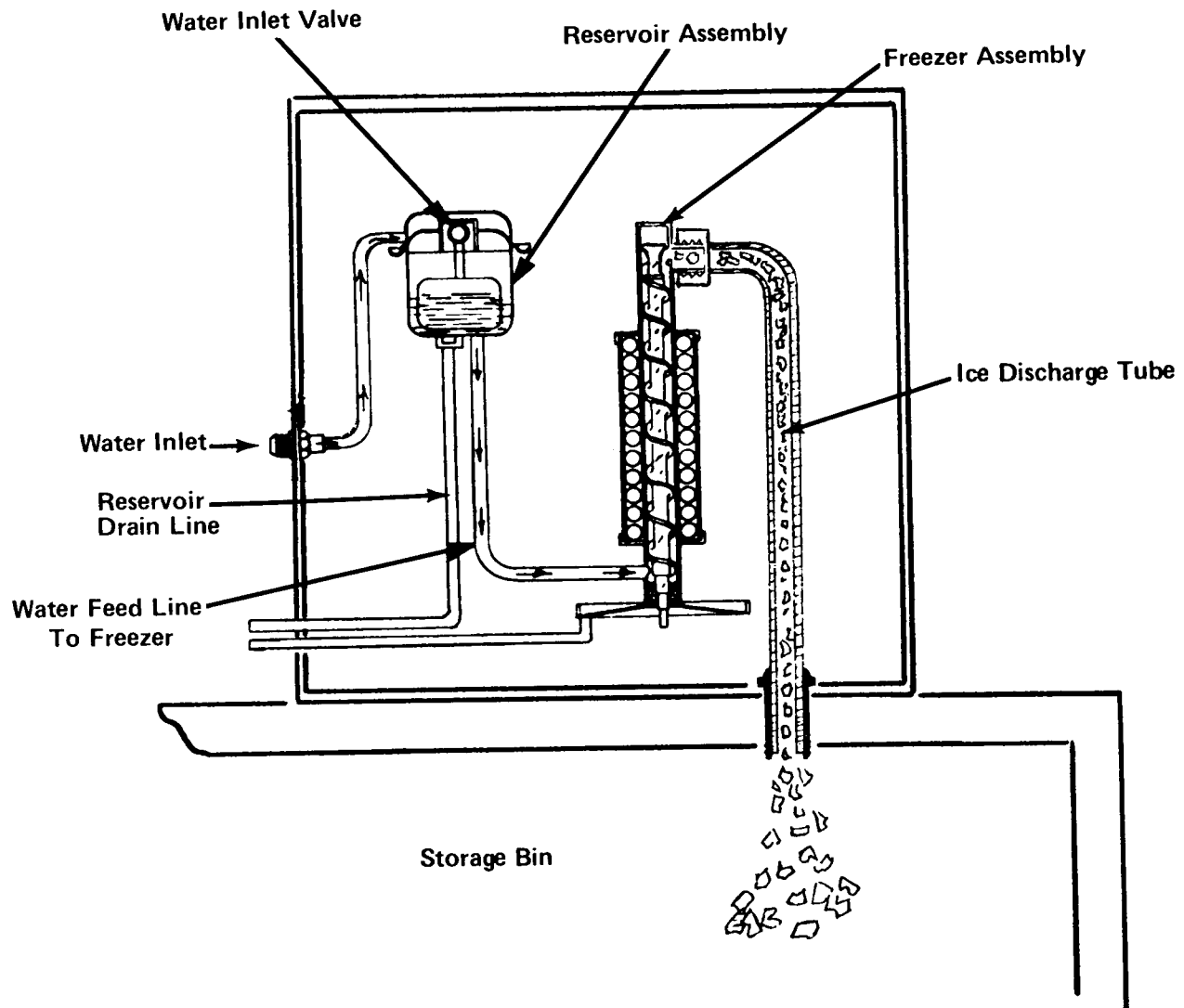

WIRING DIAGRAM  
A27045-001  
WATER COOLED

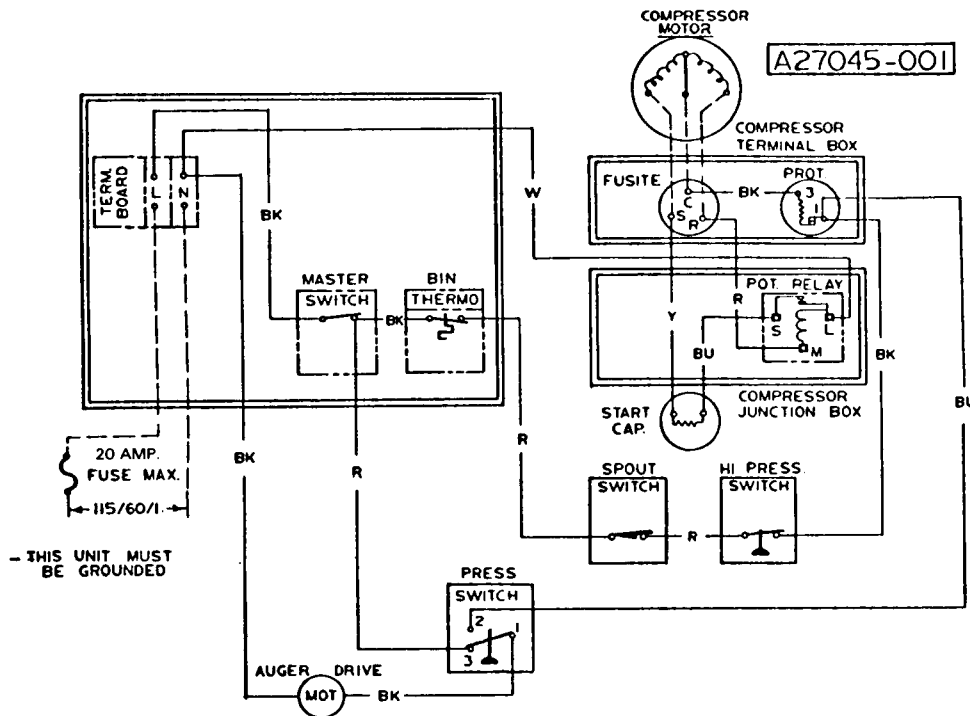

ALL CONTROLS SHOWN IN NORMAL ICE MAKING MODE

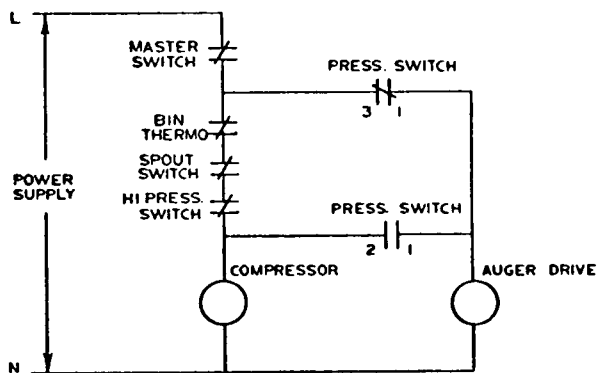

NOTE:

This diagram depicts models which **DO NOT** incorporate a gearmotor centrifugal switch. Refer to pages 33 - 36 for new model information.



WIRING DIAGRAM  
A27044-001  
AIR COOLED

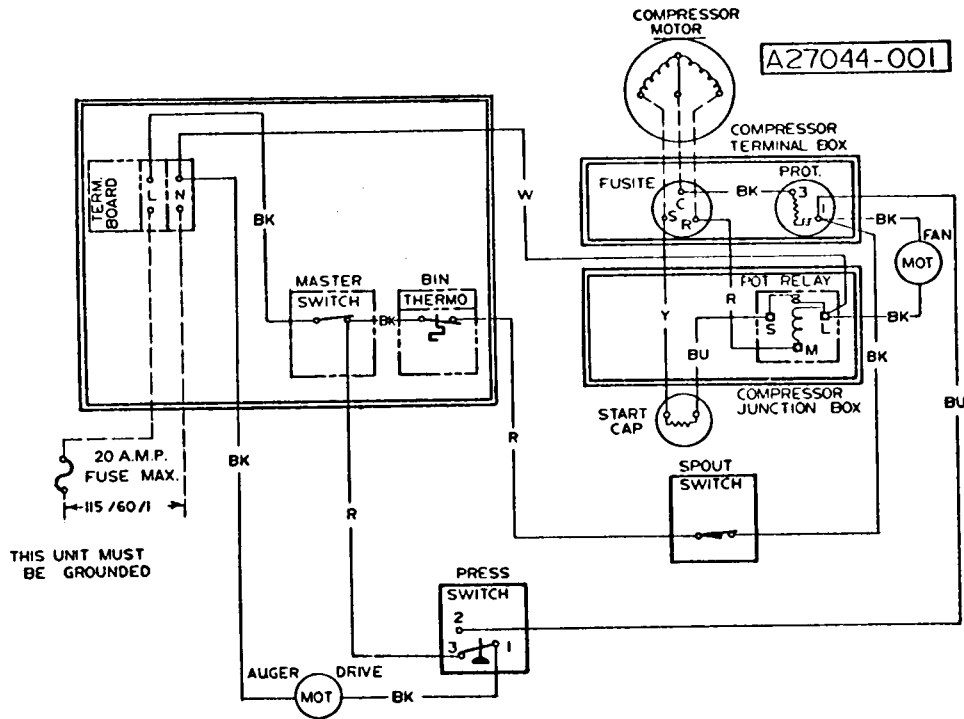

THIS UNIT MUST BE GROUNDED

ALL CONTROLS SHOWN IN NORMAL ICE MAKING MODE

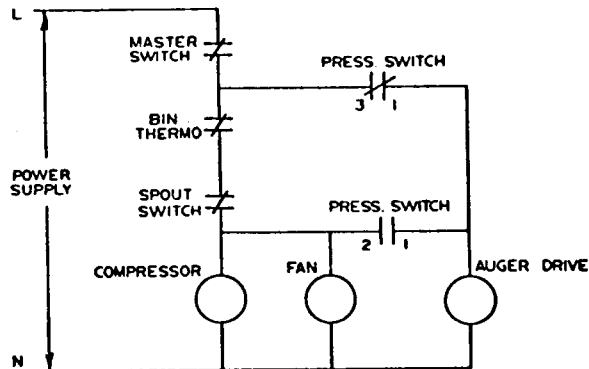

NOTE:

This diagram depicts models which **DO NOT** incorporate a gearmotor centrifugal switch. Refer to pages 33 - 36 for new model information.

SERVICE ANALYSIS

SYMPTOM	POSSIBLE CAUSE	CORRECTION
Unit will not run	Blown Fuse  Thermostat set too high  Loose electrical connection Switch in OFF position Inoperative master switch	Replace fuse and check for cause of blown fuse. Adjust thermostat. 35° cut-out and 45° cut-in. Check wiring. Turn switch to ON. Replace switch.
Compressor cycles intermittently	Low voltage Dirty Condenser Air circulation blocked Inoperative condenser motor Non-condensable gases in system	Check for overloading. Clean. Move unit to correct location. Replace.  Purge off.
Making wet ice	Surrounding air temperature Under or over-charge of refrigerant High water level in water reservoir Faulty compressor	Correct or move unit to cooler location.  Recharge with the proper amount.  Lower to 1/4 inch below overflow pipe. Repair or replace.
Low ice production	Loss of refrigerant, under or over-charge of refrigerant. Dirty or plugged condenser Low water level in water reservoir  Partial restriction in capillary tube or drier  Inlet water strainer partially plugged. Corroded or stained worm shaft due to water condition.	Check and recharge with proper amount of refrigerant. Clean condenser Adjust to 1/4 inch below overflow pipe.  Moisture in system. Overcharge of oil in System. Remove charge and drier. Replace and recharge system.  Remove screen and clean.  Remove worm shaft and clean.
Machine runs but makes no ice	Loss or under-charge of refrigerant Drive gearmotor or drive coupling stripped. Water not entering freezing chamber  Moisture in system Water seal leaking Water supply to unit off	Check for leaks and recharge  Check. Repair and/or replace. Plugged strainer or supply line. Check and clean. Air lock in gravity feed line. Check and remove air lock. Check and remove charge and drier. Replace seal Restore water supply to icemaker.

SYMPTOM	POSSIBLE CAUSE	CORRECTION
Water Leaks	Defective water seal Gravity feed line leaking "O" ring in spout casting leaking. Storage bin drain & connecting fittings leaking. Water level in reservoir too high	Replace Check hose clamps Remove spout casting and install new "O" ring.  Check and repair.  Adjust to 1/4 inch below overflow pipe
Excessive noise or chattering	Mineral or scale deposit on auger and inner freezing chamber walls.  Low suction Intermittent water supply  Water level in reservoir too low. Gearmotor loose on frame Gearmotor end-play or worn bearings.	Remove and manually polish auger, polish inner chamber walls of freezer barrel. For lighter concentrations use Scotsman Ice Machine Cleaner periodically. Add gas to raise suction pressure. Check & clean water strainer. Check gravity feed line for air lock. Remove air lock.  Adjust to 1/4 inch below overflow pipe. Tighten.  Repair or replace.
Machine continues to run with full storage bin	Storage bin thermostat not properly set.	Reset or replace. 35° cut-out, 45° cut-in Check operation with handful of ice.
Gearmotor noise	Low on oil	Remove case cover to check for proper oil level. Top of gears should be covered. Use Sun Oil Co. Prestige 50 EP, or 600 W Oil.
Gearmotor Off, Compressor On.	Micro switch on gearmotor sticking or defective.	Check - Insure centrifical switch plate activates switch.

MF3C Air Cooled

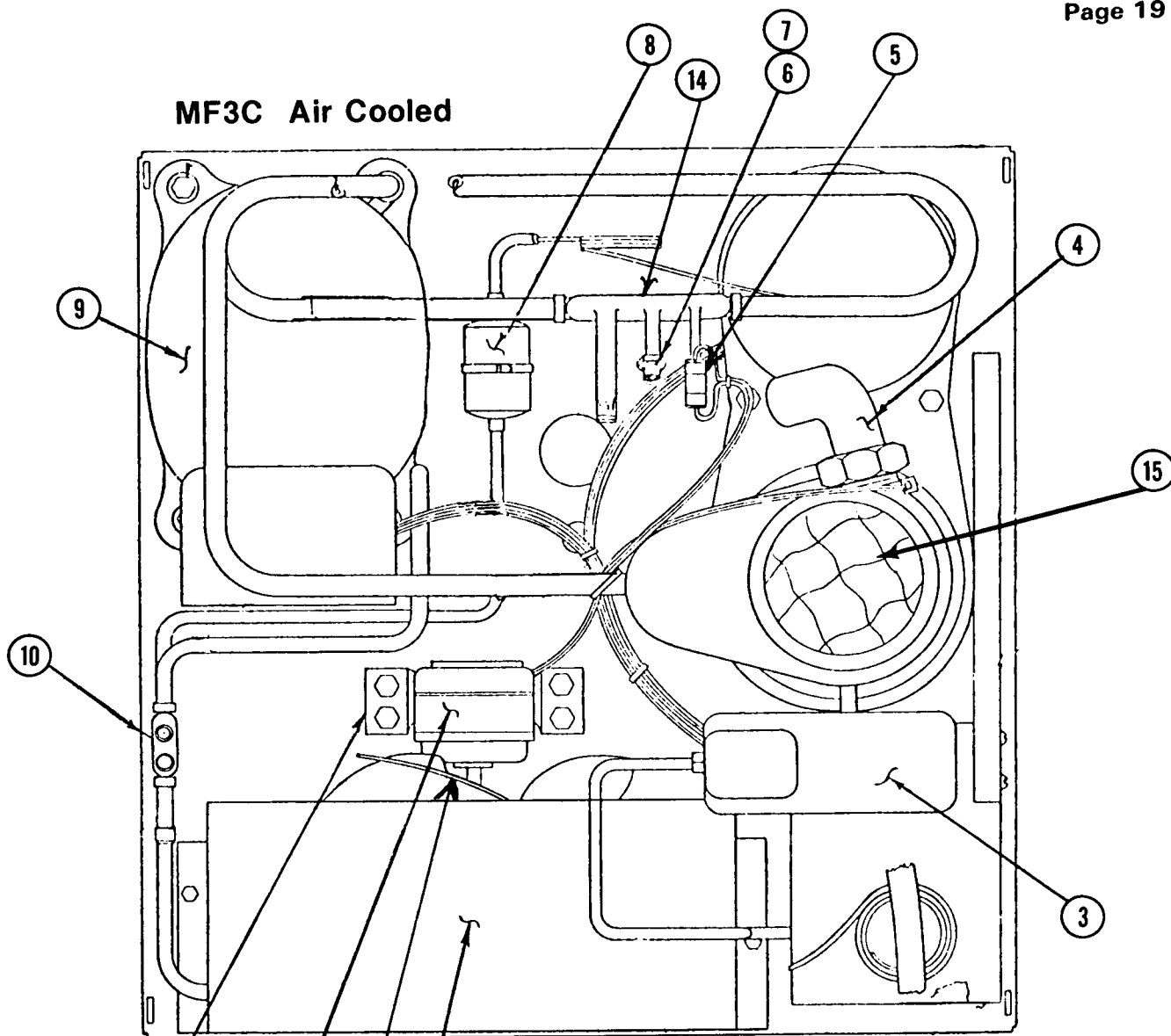

AIR COOLED CHASSIS ASSY.

- |     |            |                           |
|-----|------------|---------------------------|
| 1.  | 18-3717-01 | Condensor                 |
| 2.  | A24385-001 | Shroud (Fan)              |
| 3.  | 02-2217-01 | Reservoir Water           |
| 4.  | A26542-001 | Spout Assy                |
| 5.  | 11-0396-01 | Low Pressure Switch       |
| 6.  | 16-0560-00 | Valve Core                |
| 7.  | 16-0563-00 | Brass Cap                 |
| 8.  | 02-0831-00 | Dryer                     |
| 9.  | 18-4500-01 | Compressor                |
| 10. | 16-0673-02 | Process Header            |
| 11. | 18-0422-00 | Fan Mounting Bracket      |
| 12. | 12-1576-01 | Fan Motor                 |
| 13. | 18-3309-01 | Fan Blade                 |
| 14. | 16-0673-04 | Process Header (Low Side) |
| 15. | 13-0815-01 | Freezer Cap.              |

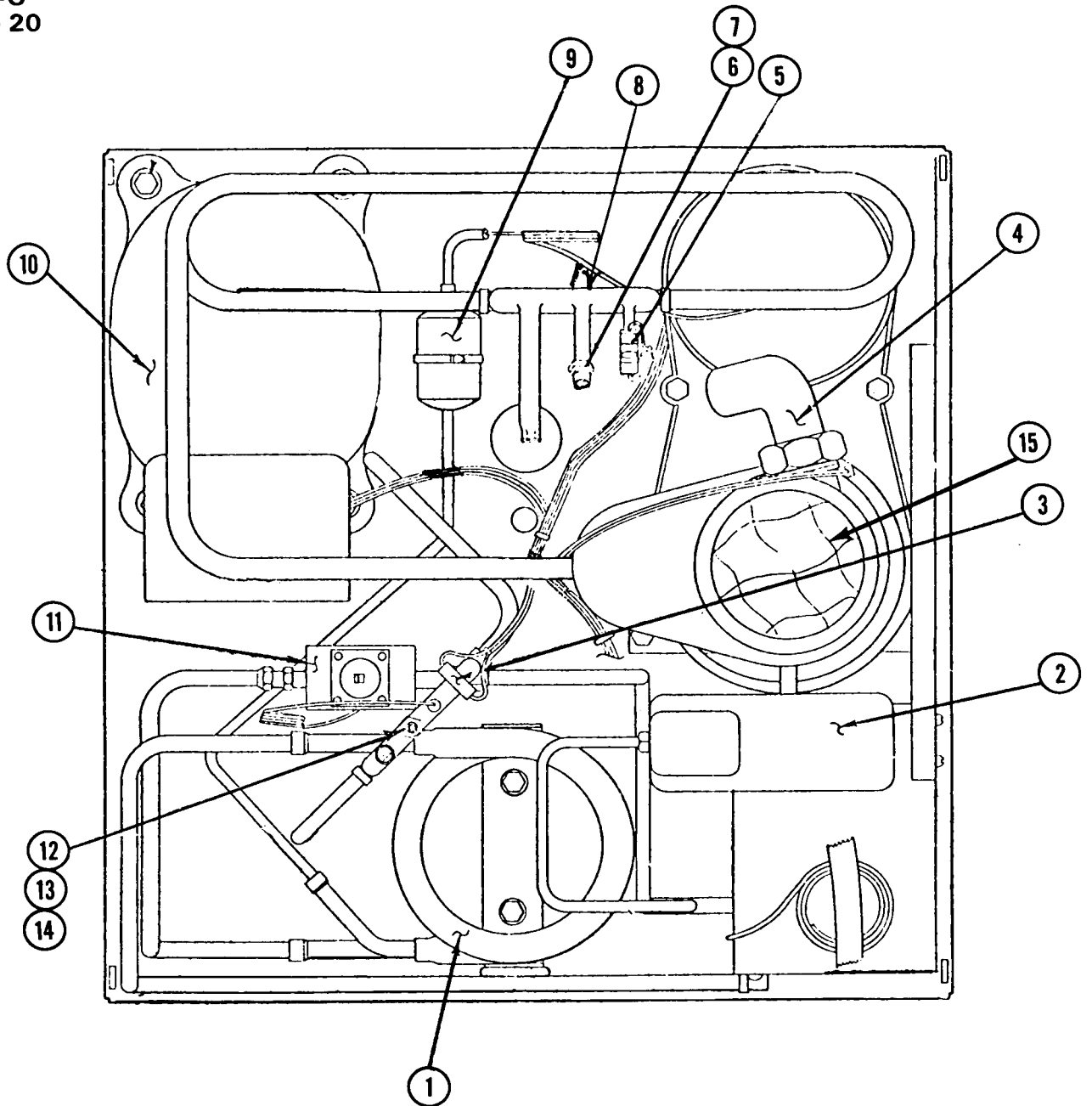

**WATER COOLED CHASSIS ASSY**

- |     |            |                           |
|-----|------------|---------------------------|
| 1.  | 18-3303-02 | Condensor                 |
| 2.  | 02-2217-01 | Reservoir                 |
| 3.  | 11-0397-01 | High Pressure Switch      |
| 4.  | A26542-001 | Spout Assy                |
| 5.  | 11-0396-01 | Low Pressure Switch       |
| 6.  | 16-0560-00 | Valve Core                |
| 7.  | 16-0563-00 | Brass Cap                 |
| 8.  | 16-0673-04 | Process Header (Low Side) |
| 9.  | 02-0831-00 | Dryer                     |
| 10. | 18-4500-01 | Compressor                |
| 11. | 11-0198-00 | Water regulator           |
| 12. | 16-0673-02 | Process Header            |
| 13. | 16-0560-00 | Valve Core                |
| 14. | 16-0563-00 | Brass Cap                 |
| 15. | 13-0815-01 | Freezer Cap               |

**FREEZER ASSEMBLY - EXPLODED VIEW - MODEL -- MF3**

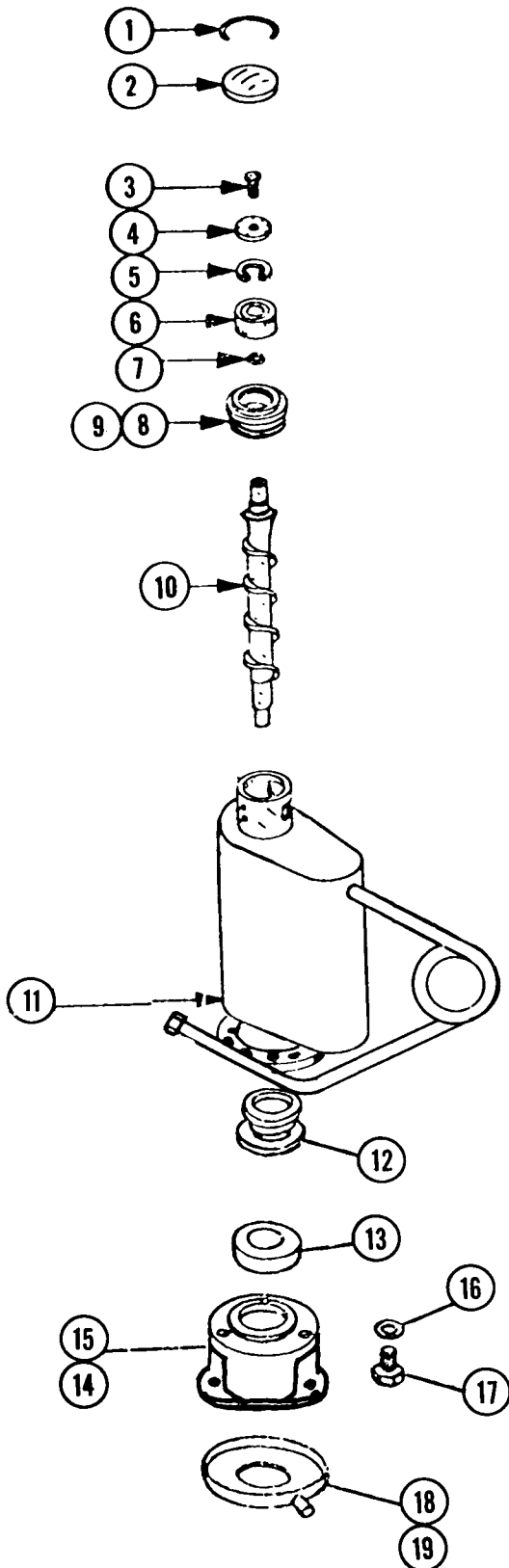

ITEM NO.	PART NO.	DESCRIPTION
1.	A08162-000	Cap Hook
2.	A07701-000	Cap
3.	03-0758-00	Cap Screw
4.	A07699-000	Washer
5.	03-1558-03	Retaining Ring
6.	02-0695-00	Bearing
7.	13-0617-16	"O" Ring
8.	A26707-001	Bearing Retainer w/Bearing
9.	13-0617-29	"O" Ring
10.	02-2046-01	Auger
11.	A27127-020	Worm Tube
12.	A18945-000	Water Seal
13.	02-0417-00	Lower Bearing
14.	03-1505-00	Adapter Gasket
15.	08-0595-01	Adapter
16.	03-1410-04	Washer
17.	03-1405-42	Screw
18.	A18153-000	Drip Pan
19.	13-0209-01	Drip Pan Gasket
20.	15-0575-01	Drive Coupling

**A25995-021**  
**GEAR MOTOR ASSEMBLY**  
**1/10 H.P.**  
**115/60/1**  
**11.5 RPM At Out Put Shaft**

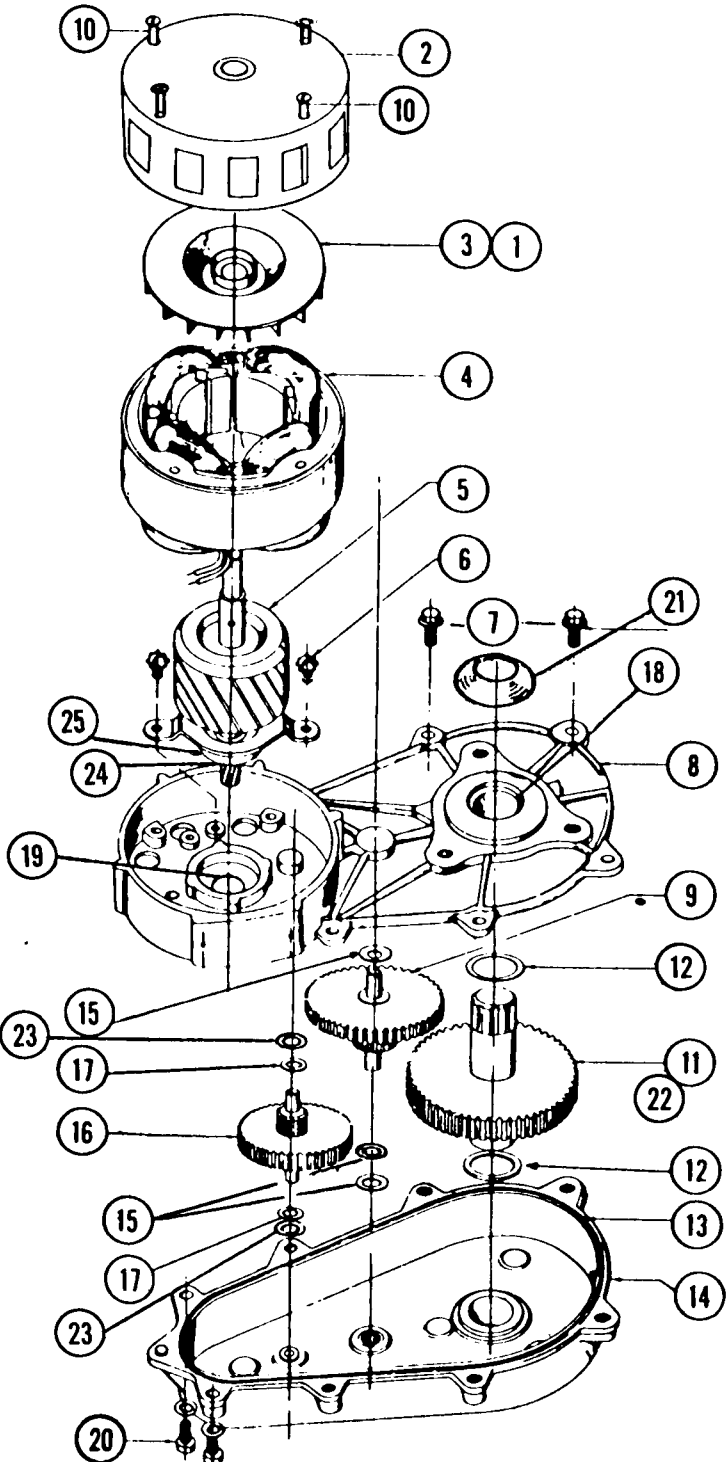

**ITEM NO. PART NO. DESCRIPTION**

- |       |            |                       |
|-------|------------|-----------------------|
| 1.    | 03-1246-00 | Set Screw (2)         |
| 2.    | A17047-000 | Motor Housing         |
| 3.    | A16915-000 | Cooling Fan           |
| 4.    | 12-1400-01 | Stator Assy.          |
| △ 5.  | A26454-001 | Rotor & 1st Gear Kit  |
| 6.    | 03-1245-00 | Screws (2)            |
| 6.    |            |                       |
| 7.    | 03-1251-00 | Flange Screws (2)     |
| △ 8.  | A16920-021 | Gear Case Cover       |
| 9.    | 02-1521-00 | Gear and Pinion       |
| 10.   | 03-1403-43 | Motor Bolts (4)       |
| 11.   | A26650-01  | Gear and Output Shaft |
| 12.   | 03-1408-21 | Washer (2)            |
| 13.   | 02-1505-00 | "O" Ring              |
| △ 14. | A24184-001 | Gear Case Kit         |
| 15.   | 03-1408-06 | Washer (3)            |
| 16.   | 02-2224-01 | 1st Gear and Pinion   |
| 17.   | 03-1408-19 | Washer (2)            |
| 18.   | 02-1503-00 | Grease Seal           |
| 19.   | 02-1504-00 | Grease Seal           |
| 20.   | 03-1252-00 | Screw (2)             |
| 21.   | 13-0709-01 | Water Shed            |
| 22.   | 03-1475-01 | Key                   |
| 23.   | 03-1408-20 | Washer (2)            |
| 24.   | 13-0617-04 | Slinger Ring          |
| 25.   | 02-1501-00 | Rotor Bearing         |

- △ 1 Cover comes with grease seals items 18 & 19.
- △ 2 Fiber gear (item 16) and rotor bearing (item 25) are in the rotor kit.
- △ 3 Includes items: 8, 13, 15, 17, 18, 19, 23 plus can of oil.

**NOTE:**

Refer also to pages 33 - 36 for additional information concerning gearmotor centrifugal switch.

COMPRESSOR 115/60/1

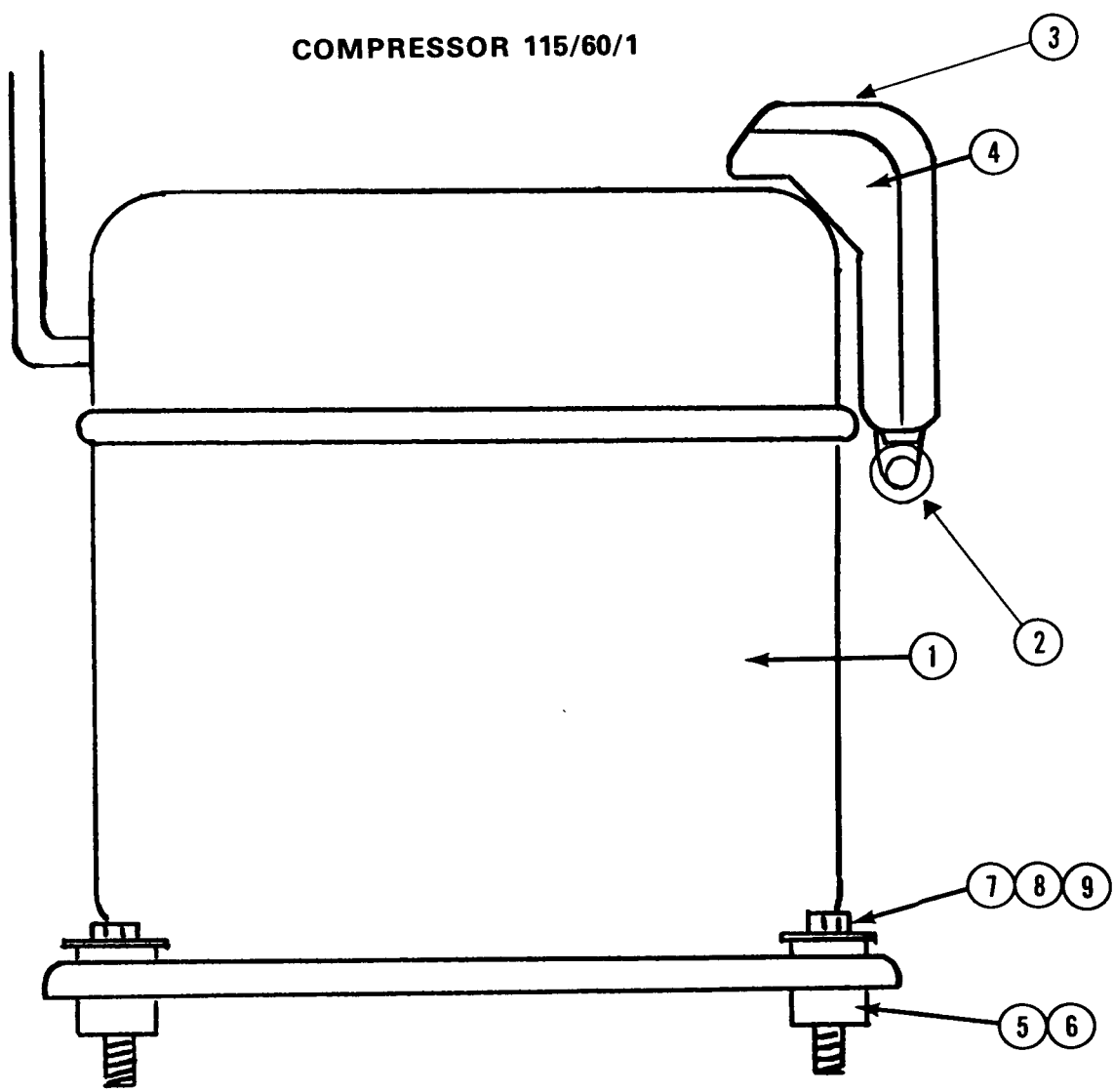

ITEM NO.	PART NO.	DESCRIPTION
1.	18-4500-01	Compressor
2.	18-1901-33	Capacitor
*3.	18-2200-26	Relay
4.	18-2200-25	Overload
5.	18-2200-27	Sleeve (4)
6.	18-2200-28	Grommet (4)
7.	03-1405-40	Screw (4)
8.	03-1417-12	Washer (4)
9.	03-1408-02	Washer (4)

\*Not Shown



**CONTROL BOX ASSEMBLY  
WATER AND AIR COOLED**

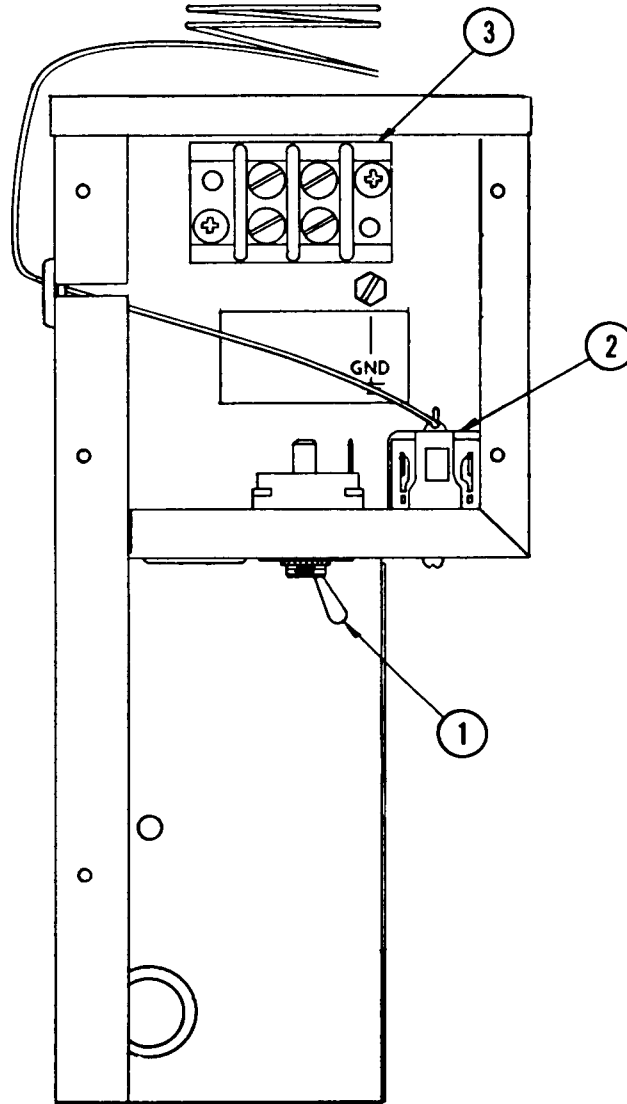

- |    |                |            |
|----|----------------|------------|
| 1. | Master Switch  | 12-0426-01 |
| 2. | Temperature    | 11-0354-00 |
| 3. | Terminal Board | 12-0813-04 |

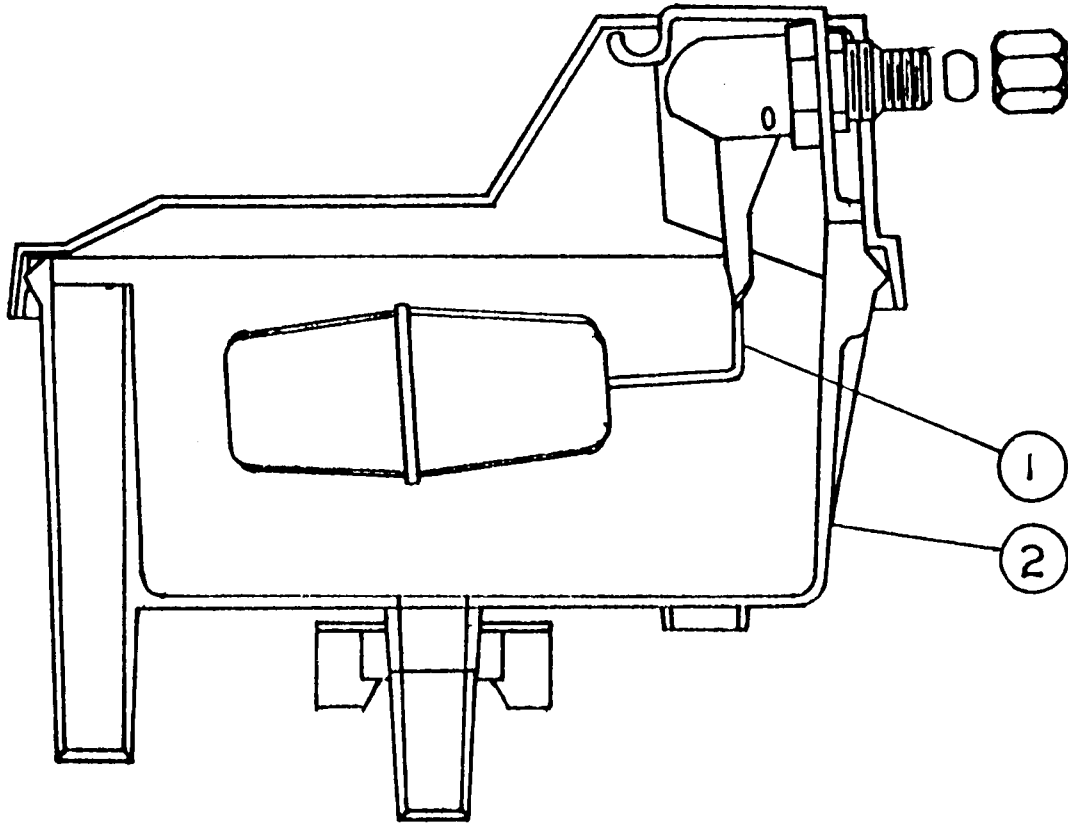

## RESERVOIR ASSEMBLY

ITEM NO.	PART NO.	DESCRIPTION
1.	02-2217-02	Valve Assy.
2.	02-2217-01	Reservoir Complete

CABINET PARTS

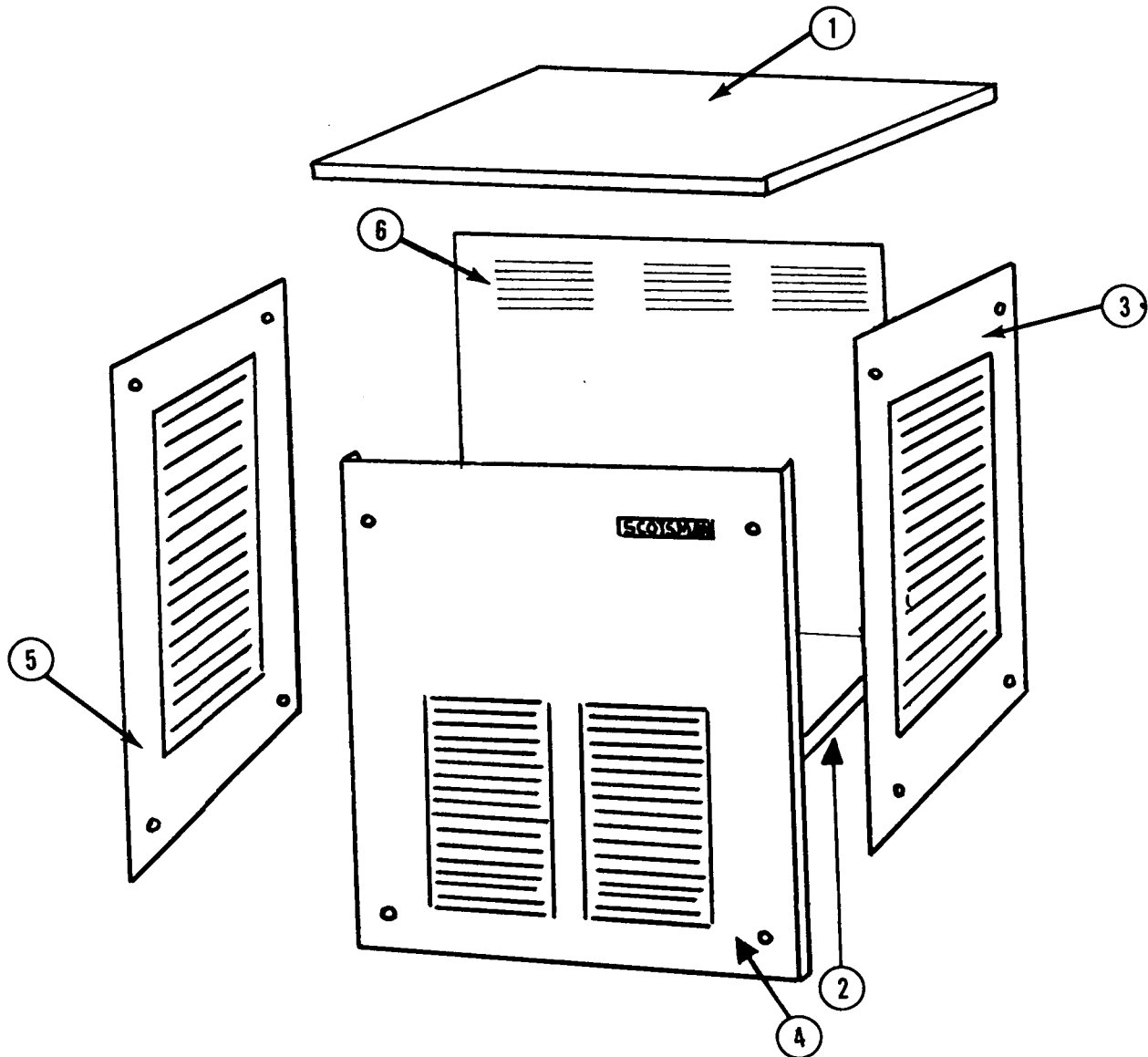

ITEM NO.	DESCRIPTION	ENAMEL	STAINLESS STEEL
1.	Panel Top	A26625-001	A26625-002
2.	Cabinet Base	A27103-001	Same
3.	Panel, Right Side	A26624-001	A26624-002
4.	Panel, Front	A27111-001	A27111-002
5.	Panel, Left Side	A26623-001	A26623-002
6.	Panel, Rear	A26622-001	A26622-002
*	Mounting Screws	03-1414-09	Same 4/Panel
*	Aerosol Paint (micromatte)	10-0314-01	

\*Items not illustrated

**SPOUT AND SAFETY SWITCH**

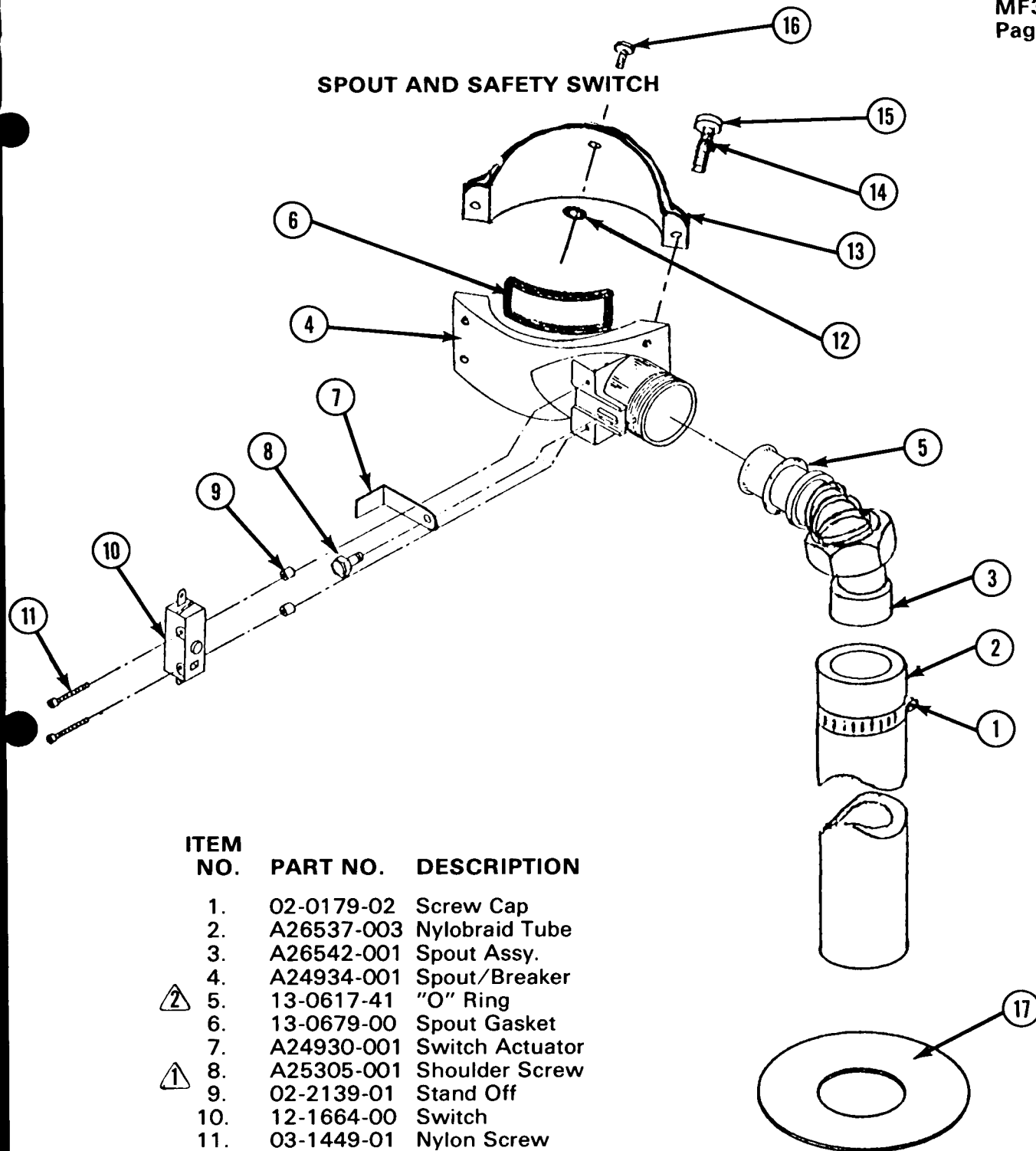

ITEM NO.	PART NO.	DESCRIPTION
1.	02-0179-02	Screw Cap
2.	A26537-003	Nylobraid Tube
3.	A26542-001	Spout Assy.
4.	A24934-001	Spout/Breaker
⚠ 5.	13-0617-41	"O" Ring
6.	13-0679-00	Spout Gasket
7.	A24930-001	Switch Actuator
⚠ 8.	A25305-001	Shoulder Screw
9.	02-2139-01	Stand Off
10.	12-1664-00	Switch
11.	03-1449-01	Nylon Screw
12.	03-1409-14	Rubber Washer
13.	A18430-002	Spout Plate
14.	03-1417-07	Lockwasher (4)
15.	03-1544-03	Socket Head Screw (4)
16.	03-1506-01	Screw
17.	13-0806-01	Sealing Pad

**NOTE:**

- ⚠ Tighten carefully, small thread & brass
- ⚠ A light coating of petro-jel required on "O" Ring & Spring

**Description of the Function of the Texas Instruments Low Pressure Control Switch When Used on 1/10 H.P. Gear Motors**

On all Scotsman units using a 1/10 H.P. gear motor, the centrifugal switch mechanism, mounted on top of the motor, was removed and replaced, in the system, with a low pressure control switch. This is a single pole double throw (SPDT) switch manufactured by Texas Instruments. (Queen Products Part No. 11-0396-01\*).

\*Refer to a typical wiring diagram, showing contacts, for description of switch function.

On all Queen Products wiring diagrams, the controls are shown in the ice making mode. Thus, the 1-3 contacts are shown as closed. On machine start up the 1-3 contacts are open and the 1-2 contacts are closed. As the unit begins to run, the low side pressure starts to fall from the stabilized or "at rest" pressure. As soon as the pressure drops to 20 Psig, the 1-2 contacts open and the 1-3 contacts close. This removes the operating controls, such as the bin thermostat, from the "gear motor circuit". If one of the operating controls opens, it will shut off the "compressor circuit". The gear motor will run until the low side pressure rises to 32 Psig. At this point the 1-3 contacts open and turns the gear motor off. This usually takes 1-3 minutes depending on ambient conditions. This length of time allows the auger to transport all the ice out of the freezing chamber. Consequently, when called on to start up again, there is no load to start up against. On start up, again, the 1-3 contacts are open and the 1-2 contacts closed.

\*Function 11-0396-01 Low Pressure Control Switch

1-3 Contacts - Open on Pressure Rise  
Opens at 32 Psig  
Closes at 20 Psig

1-2 Contacts - Open on Pressure Fall  
Opens at 20 Psig  
Closes at 32 Psig

ALL CONTROLS SHOWN IN NORMAL ICE MAKING MODE

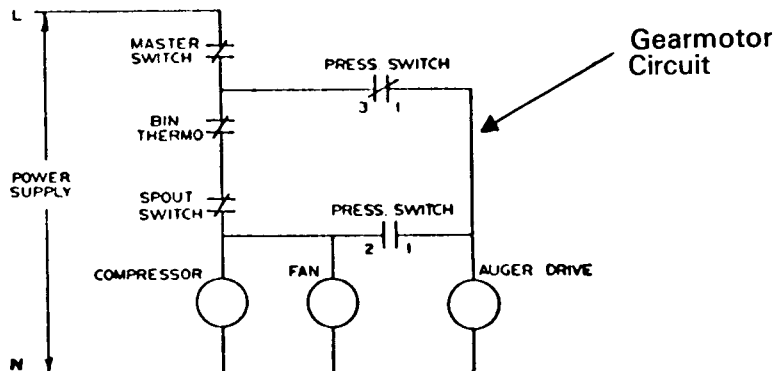

**NOTE:** Refer also to Pages 33 - 36 for additional information concerning Gearmotor Centrifugal Switch.

#### TO REPLACE: FREEZER GEAR MOTOR

1. Remove top, front and side panels.
2. Shut off water supply and disconnect electrical power to unit.
3. Remove electrical leads from motor to control box.
4. Remove slip nut attaching ice discharge tube to freezer spout casting.
5. Next remove 3 bolts securing base adapter to gear motor cover and the 4 bolts holding the gear motor bracket to the cabinet base.
6. Lift freezer and adapter assembly off gear motor and pull gear motor and mounting bracket out of cabinet.

#### FREEZER ASSEMBLY

##### TO REPLACE:

1. To remove freezer first remove cabinet top, front and side panels.
2. Shut off water supply and disconnect electrical power to unit.
3. Drain reservoir and freezer of water by removing tygon tubing entering base of freezer.
4. Remove slip nut attaching ice discharge tube to freezer spout casting.
5. Purge off refrigerant and unsweat suction line. Disconnect capillary line at drier. Cap off all lines so no moisture can enter system.
6. Remove the 3 bolts securing freezer base adapter to top of gear motor cover.
7. Freezer assembly now can be lifted off gear motor and out of cabinet.
8. To re-install reverse procedure. Refer to section "Specifications" for proper refrigerant charge and to page 11 for Head and Back pressure settings.

#### FREEZER WORM SHAFT (AUGER)

##### TO REPLACE:

1. Disconnect electrical supply and shut off water to unit.
2. Remove top and front panel of cabinet.
3. Drain reservoir and freezer of water by removing tygon tubing entering base of freezer.
4. Next remove slip nut attaching ice discharge tube to freezer spout casting and insulation covering top of freezer chamber.
5. Remove the 4 bolts attaching the freezer spout casting to the spout bracket and remove spout casting. Also remove bracket by removing the stainless steel screw which secures the bracket to the freezer chamber.
6. By lifting up on the freezer cap pull ring, the complete worm shaft and bearing retainer can be removed from freezer chamber. NOTE: Top half of water seal is attached to the lower end of the worm shaft.

### FREEZER ASSEMBLY TOP BEARING

**TO REPLACE:**

1. Follow steps 1 thru 6, freezer worm shaft removal.
2. To remove bearing and retainer from worm shaft, first remove retaining ring in top of bearing retainer.
3. Remove freezer cap and pull ring from bearing retainer.
4. Unscrew cap screw holding shaft to inner race of bearing and pull worm shaft free from bearing and retainer.
5. When replacing with a new bearing add new grease (Beacon No. 325) to top of bearing.

### FREEZER ASSEMBLY BOTTOM BEARING AND WATER SEAL

**TO REPLACE:**

1. To replace, follow steps 1 through 6 under Worm Shaft Removal.
2. Remove 3 bolts holding freezer to mounting adapter.
3. Lift freezer off adapter just high enough to allow bottom bearing and bottom half of water seal to be removed from bottom of freezer tube.
4. Lightly grease bottom half of new water seal and insert face up approximately 1/2" in bottom of freezer tube.
5. Insert bottom bearing in bottom of freezer tube, force approximately 1/8" past bottom tube end. This will allow the positioning ring on adaptor to properly position freezer tube when tightening up the three mounting bolts.
6. After securing mounting bolts, put new top half of water seal on worm shaft the same way as the old seal was removed. When reassembling, put a small amount of Vaseline on shaft end. This will allow shaft to slide smoothly through rubber bottom half of water seal without tearing it.
7. Carefully insert worm shaft assembly in freezer tube and into spline coupling on bottom.
8. Replace spout casting, screws, insulation pieces and unit is ready to resume operation.

### BIN THERMOSTAT:

Thermostat control body is located in electrical control box. The thermostat sensing tube is threaded into the ice storage bin where it automatically stops the icemaker when ice bin fills to sensing tube level and restarts icemaker when ice is removed. Factory settings are 35° cut out, 45° cut in.

Altitude correction begins at 2,000 feet, cut in and cut out screws should be adjusted equally, not more than 1/4 turn at a time.

**IMPORTANT** — Refer to page 7 for proper location of bin control capillary.

**TO REPLACE:**

1. Disconnect electrical supply.
2. Remove bin thermostat capillary tube from bin location.
3. Remove front panel and control box cover.
4. Disconnect two spade type electrical leads.
5. Loosen two screws in control mounting bracket.
6. Replace with new control and reassemble in reverse of above.
7. **CAUTION:** Always check new control power element charge before installation to assure receiving an operative control. A handful of ice on bulb will register on audible 'click' at cut off.

### HEAD PRESSURE CONTROL (WATER COOLED MODELS)

The head pressure safety control is factory preset at 250 lb. PSIG. This is a manual reset control. The control is placed in the system as a safety precaution, to terminate power to the unit should loss of water occur to the water cooled condenser.

### WATER REGULATING VALVE (Water Cooled Models Only)

The Water Regulating Valve is designed to maintain a constant head pressure by regulating the amount of incoming water flow through the water cooled condenser. This valve is operated by high side pressure and may be adjusted by the adjusting screw on top of the valve to raise or lower the operating head pressure.

#### TO REPLACE:

1. Shut off water supply to machine and disconnect electrical power.
2. Disconnect old valve from water supply line and install new valve.  
NOTE: Be sure arrow on side of valve points in direction of water flow.
3. Purge off refrigerant and disconnect valve capillary line from high side fitting and immediately attach capillary from new valve.
4. Recharge system. Refer to page 11 for proper refrigerant charge and head and pressure settings.

### WATER RESERVOIR

A water level is maintained in the water reservoir by a float operated valve. Water is piped from the water reservoir to the freezing chamber by a gravity feed line maintaining an equal water level.

The water reservoir is equipped with a 2 inch air gap to prevent back siphoning and meet all health codes.

The water level in the water reservoir is adjusted by bending float arm. The water level should be set 1/4 inch below the overflow standpipe.

A water strainer must be installed in the supply line. Use strainer sent with machine.

#### TO REPLACE:

1. Remove cabinet top and side panel.
2. Turn off water supply and drain reservoir.
3. Remove 1/4 inch inlet water line.
4. Remove plastic feed line to freezer.
5. Remove two screws holding reservoir bracket to wall.
6. Lift out reservoir.
7. To replace, reverse procedure.



### MAINTENANCE INSTRUCTIONS – FLAKERS

THE FOLLOWING MAINTENANCE SHOULD BE SCHEDULED THREE TIMES PER YEAR ON ALL SCOTSMAN MODULAR FLAKERS. CALL YOUR AUTHORIZED SCOTSMAN SERVICE DEPARTMENT.

1. Check and clean water strainers and float valve. Depress float valve to insure full stream of water.
2. Check water level and machine level, keep water level below overflow, but as high as possible and still not run out of spout opening with machine off. Water droplets come out of spout with ice at all times. Adjust as required.
3. Clean reservoir and interior of freezer using SCOTSMAN Ice Machine Cleaner.

If machine has been cleaned regularly and no problems such as dry ice or chatter are noticed, clean as per the following instructions:

- a. Set main switch to OFF.
- b. Remove all ice from storage bin.
- c. Turn off water supply or block float. Drain reservoir by disconnecting tube between reservoir and freezer. After draining, reconnect tubing.
- d. Set main switch to ON and pour cleaning solution into reservoir. Do not fill above overflow tube.

Use 6 oz. of Scotsman cleaner and 1-1/2 qts. hot water.

- e. Continue to make ice on solution until the solution is used up and reservoir is empty.
- f. Set main switch to OFF Remove overflow tube, wash and rinse reservoir, replace overflow tube, turn water on or remove float block.
- g. Turn MAIN SWITCH to ON. Let unit run for at least (15) minutes to flush out any cleaning fluid. Check ice for acid taste – run until ice tastes sweet.
- h. Turn MAIN SWITCH to OFF. Add hot water to ice bin, using the melt water, thoroughly wash and rinse all surfaces within the storage bin.
- i. Turn MAIN SWITCH to ON. Replace Service Door. Unit is ready for normal operation.

NOTE: Cleaning requirements vary according to local water conditions. Visual inspection of the auger before and after cleaning will indicate best procedure to be followed in local areas.

4. Check high and low side pressures. On air-cooled models head pressures range between 130 and 145 PSI. Suction pressure should be above 12 PSI and will range up to 15 PSI depending upon water and ambient temperatures.
5. Check gear motor operation. Normal running temperatures are in the area of 160° Fahrenheit, which is hot to the touch.
6. Check top bearing of freezing tube. Remove retainer ring around edge of stamped brass cap. If moisture is around bearing, wipe up and remove grease. Add new grease. Use Beacon No. 325. Replace cap and retainer ring.
7. Clean air-cooled condenser. Inform customer to clean frequently. Always shut off machine when cleaning.
8. Oil condenser fan motor when possible.
9. Check for refrigerant leaks and proper frost line. Should frost out of accumulator at least one-half way to compressor, and in some areas back to service valve.
10. Check for water leaks. Tighten drain line connections. Run water down bin drain line to make sure it is open.
11. Check quality of ice. Ice should be wet when formed, but will cure rapidly to normal hardness in bin.
12. Check thermostat. Bin thermostat should be set at 10° Differential 35° cut out, 45° cut in.

**GEAR MOTOR ASSEMBLY/CENTRIFUGAL SWITCH**  
Part #A25995-001

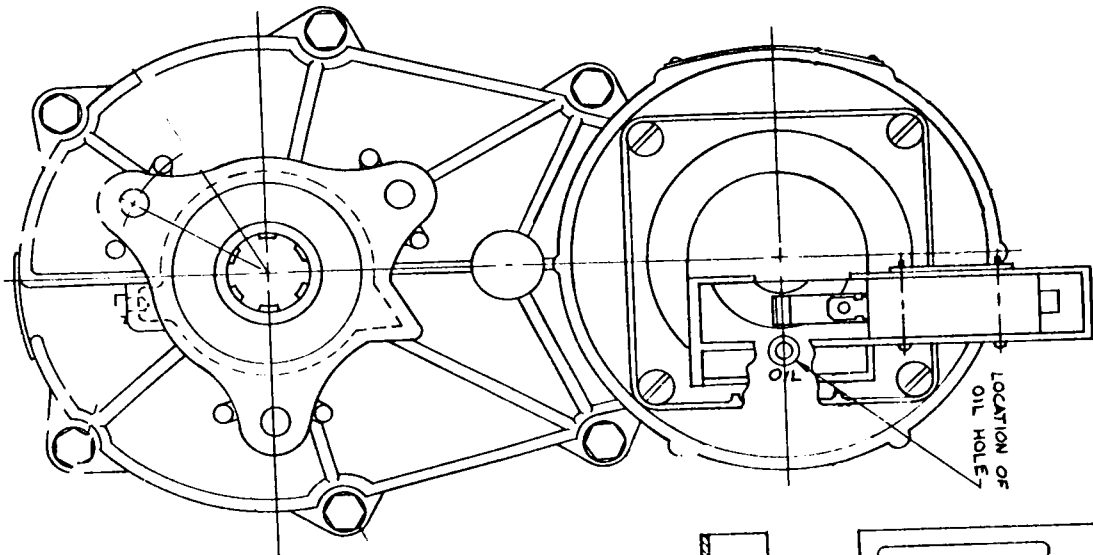

New style centrifugal switch started with MF3 "C" models. Approximate serial number starting usage is: 317613-7C.

MF3 models prior to above may be converted to current standard using Kit Part #A27494-01 shown on next page.

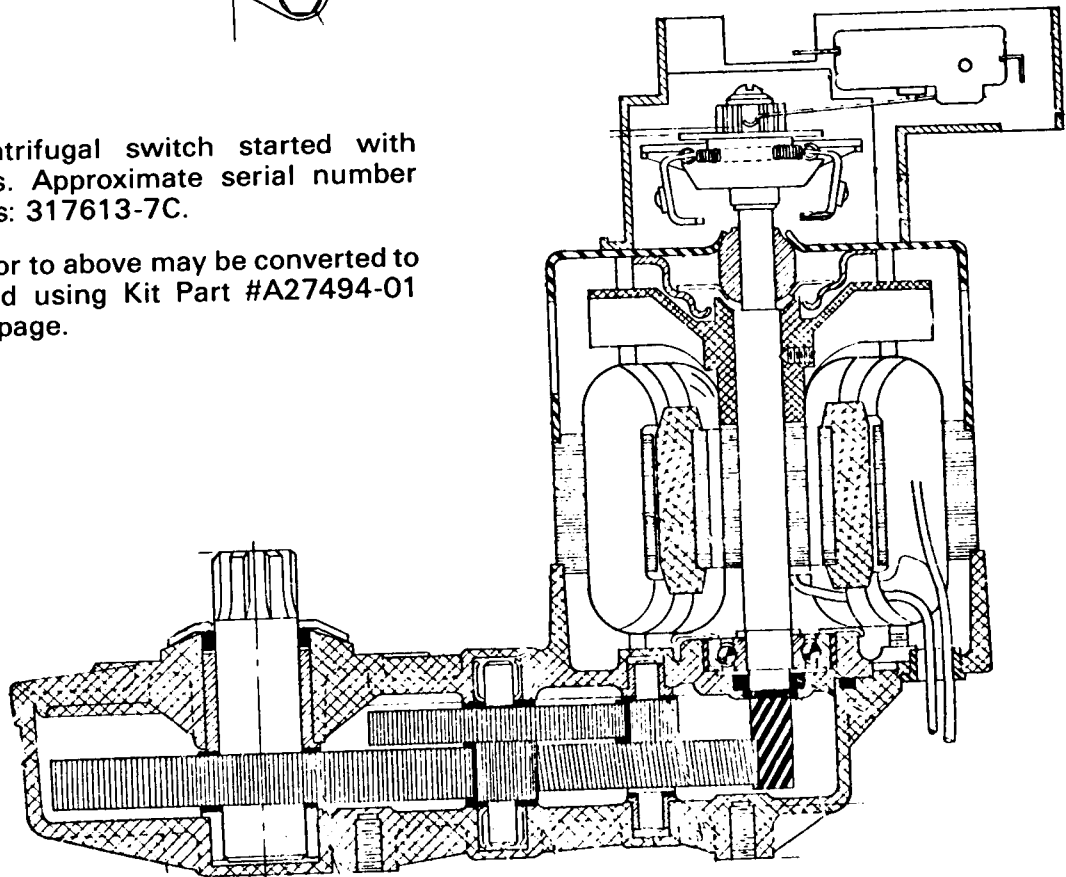

## CENTRIFUGAL SWITCH KIT INSTALLATION INSTRUCTIONS

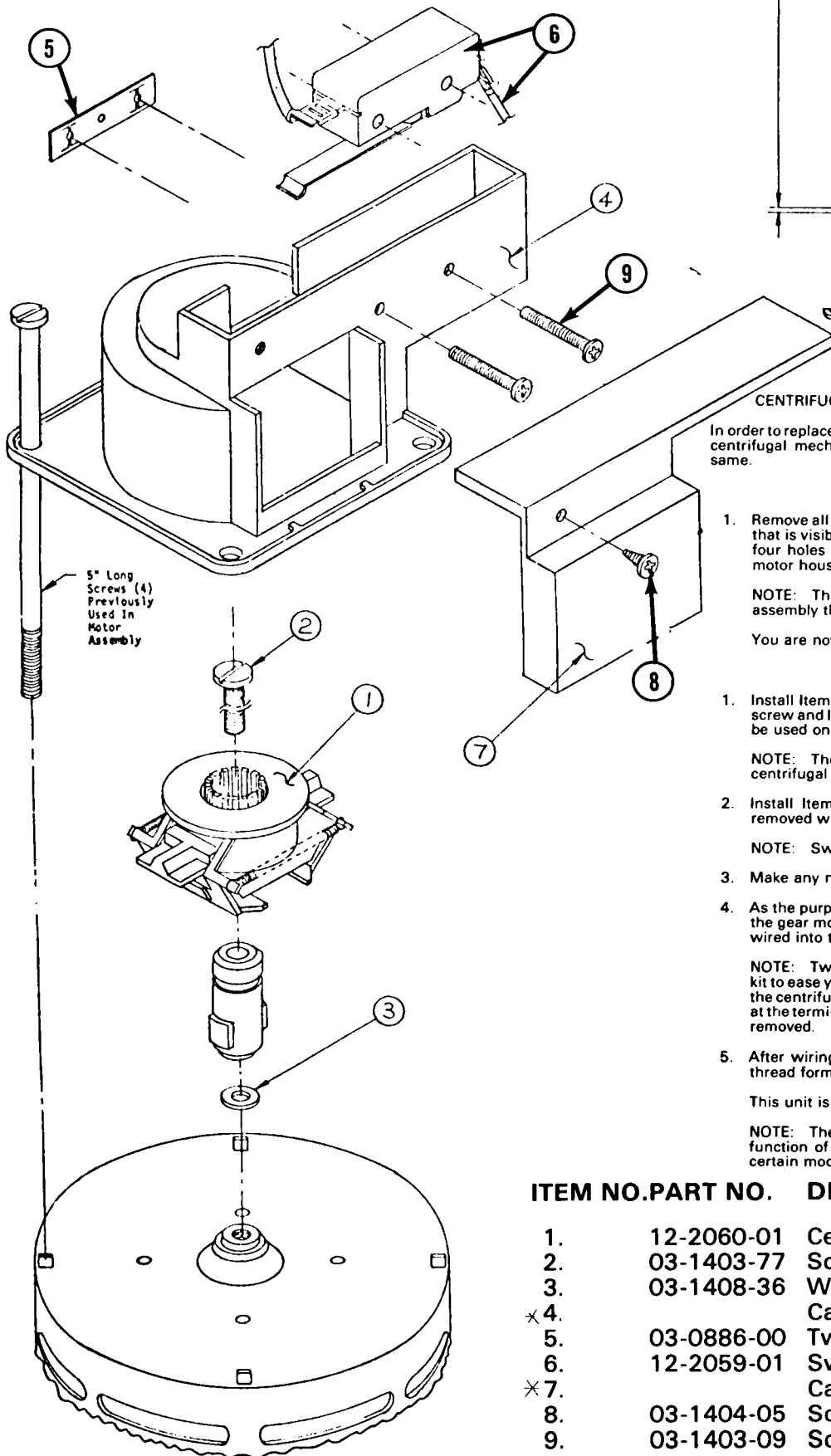

### SWITCH ADJUSTMENT

.03 minimum gap between switch lever and mechanism with centrifugal mechanism actuated (motor running). Switch circuit should be closed. When motor is stopped and centrifugal mechanism deactivates, the switch circuit should be broken. There should be enough adjustment by loosening the switch mounting screws and tilting switch in direction required. If this fails, a small amount of bending can be done on the switch lever.

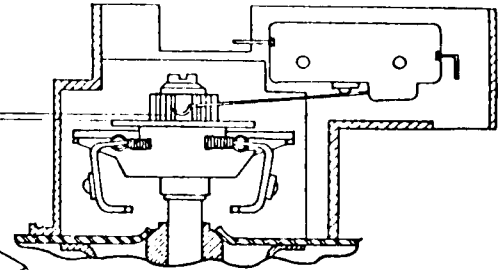

### CENTRIFUGAL MECHANISM INSTALLATION INSTRUCTIONS

In order to replace an existing centrifugal mechanism or just adding this new centrifugal mechanism into your unit, the installation procedure is the same.

#### REMOVAL

1. Remove all existing hardware from the top of the drive motor so that all that is visible on the top of the motor is the shaft of the motor and the four holes left vacant by the motor support screws. Do not remove motor housing cover.

NOTE: These four screws (approximately 5" long) will be reused to assembly the new mechanism.

You are now ready to install the new mechanism.

#### INSTALLATION

1. Install Item 1 centrifugal actuator to motor shaft with Item 2 #10-32 screw and Item 3 small flat washer. A small amount of Locktite should be used on the screw threads to prevent screw from backing out.

NOTE: The shaft extension shown has been factory installed into the centrifugal actuator for your convenience.

2. Install Item 4 switch case using four 5" long screws previously removed when disassembling unit.

NOTE: Switch has been factory installed for your convenience.

3. Make any necessary adjustments noted in sketch above.

4. As the purpose of this mechanism is to turn the compressor off when the gear motor slows down, the switch in this mechanism should be wired into the neutral line of the compressor.

NOTE: Two white wires Items 5 and 6 have been furnished with this kit to ease your assembly. The insulated terminals should terminate at the centrifugal switch. The remaining ends of these wires will connect at the terminals vacated when the neutral wire from the compressor is removed.

5. After wiring has been completed, install Item 7 cover, with Item 8 thread forming screw.

This unit is now optional.

NOTE: The intent of this mechanism is not in any way related to the function of the Texas instrument low pressure switch installed in certain models.

### ITEM NO. PART NO. DESCRIPTION

1.	12-2060-01	Centrifugal Actuator
2.	03-1403-77	Screw
3.	03-1408-36	Washer
*4.		Case
5.	03-0886-00	Twin Speed Nut
6.	12-2059-01	Switch
*7.		Case Cover
8.	03-1404-05	Screw
9.	03-1403-09	Screws 2/Unit

### KIT PART #A27494-01

\*Items 4 and 7 Supplied in Kit A27895-001.

**WIRING DIAGRAM**  
115/60/1  
Water Cooled

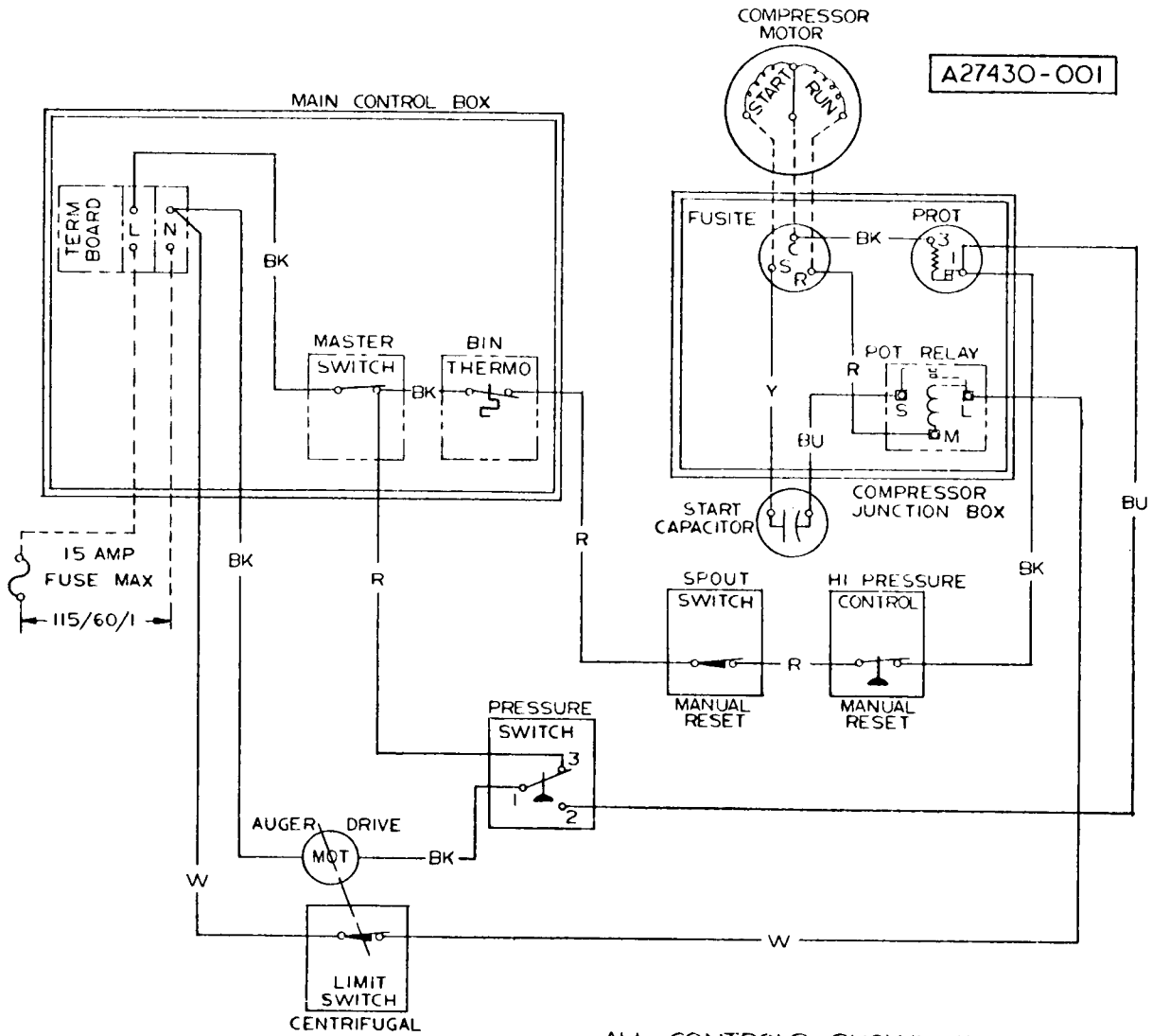

ALL CONTROLS SHOWN IN  
NORMAL ICE MAKING MODE

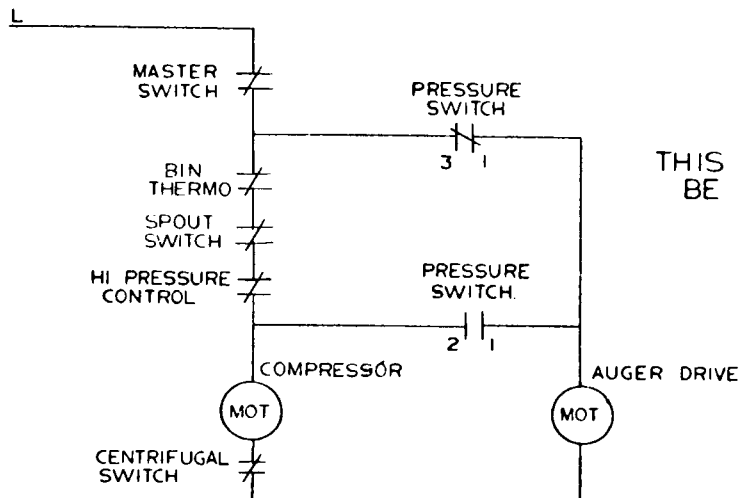

THIS UNIT MUST  
BE GROUNDED

WIRING DIAGRAM  
115/60/1  
Air Cooled

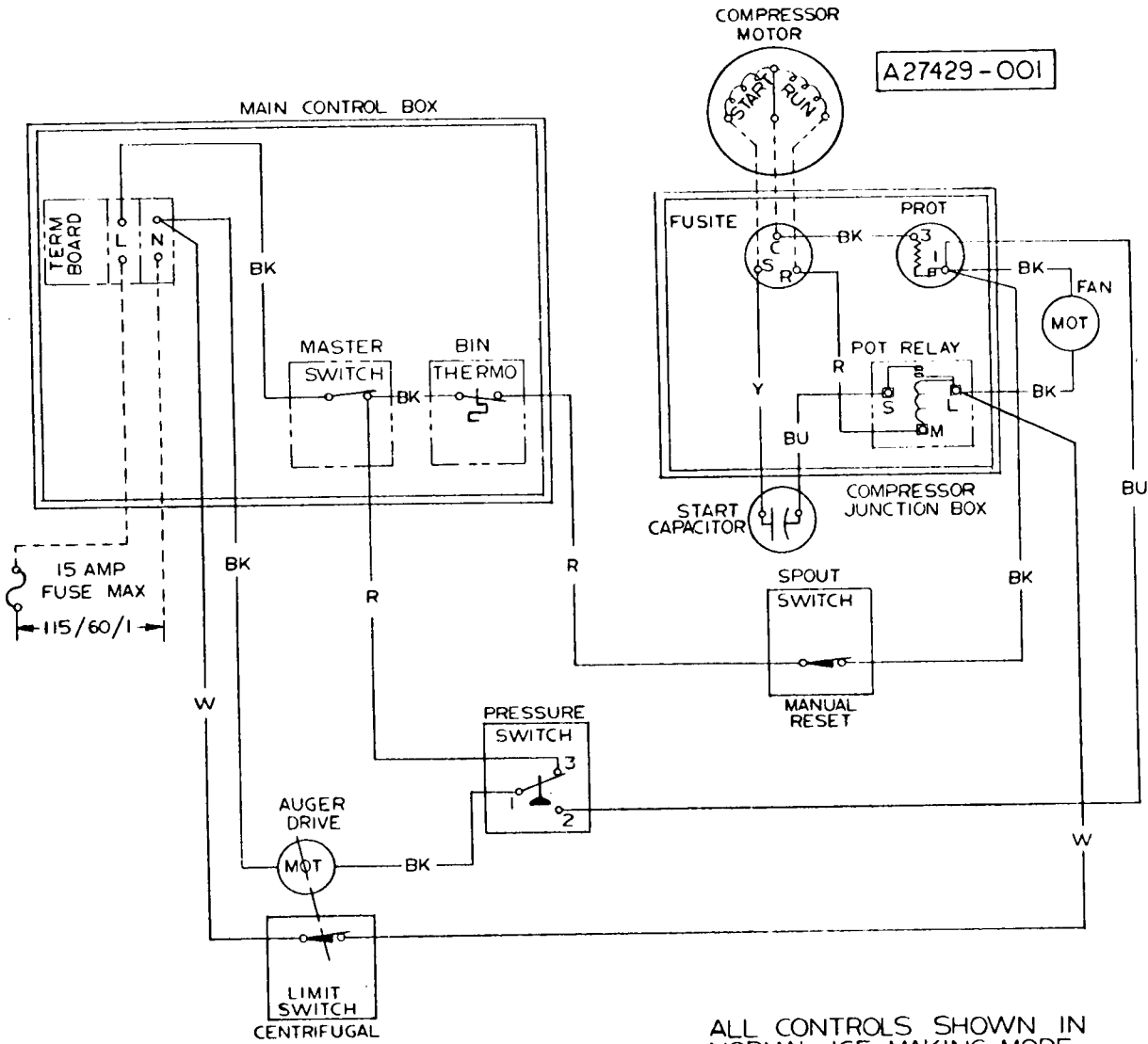

ALL CONTROLS SHOWN IN  
NORMAL ICE MAKING MODE

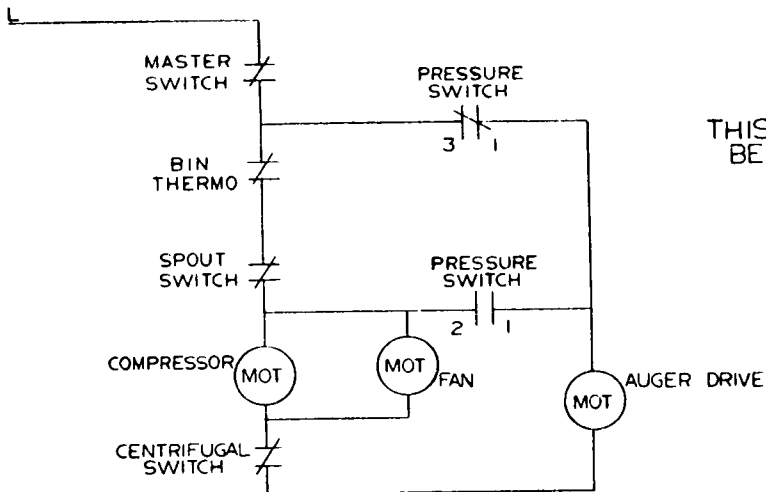

THIS UNIT MUST  
BE GROUND