

HQD550

TABLE OF CONTENTS

GENERAL INFORMATION & INSTALLATION		
Introduction	2	
Location and Leveling	5	
Wall Mount Instructions	6	
Water Dispensing System	8	
Valve Kit	9	
Electrical Connections	10	
Water Supply and Drain Connections	11	
Final Check List	12	
OPERATING INSTRUCTIONS		
Start-Up	14	
Dispensing System	16	
Icemaker	17	
Electrical/Refrigeration	17	
COMPONENT DESCRIPTION		19
MAINTENANCE & CLEANING INSTRUCTIONS		
General	25	
Icemaker	25	
Sanitizing	28	
SERVICE DIAGNOSIS		30
ADJUSTMENT PROCEDURES		
Leg Levelers	33	
Water Regulator Assembly	33	
Water Reservoir Float	33	
REMOVAL AND REPLACEMENT PROCEDURES		
Auger, Water Seal, O-Ring, Ice Breaker Assembly and Freezer	34	
Compressor Assembly	37	
Condenser Assembly - Air-Cooled	37	
Condenser Assembly - Water-Cooled	37	
Drier	39	
Fan Motor Assembly	39	
Inner Bin Drive Motor Assembly	39	
Elbow and Switch Assembly	40	
Water Pressure Switch Assembly	41	
Water Regulator Assembly - Water-Cooled Models	41	
Water Reservoir Assembly	41	
Gear Motor	42	

LIST OF ILLUSTRATIONS

Specifications	3	
HQD550 - Component Location	4	
Location and Leveling	5	
Wall Mount Instructions	6	
Water Dispensing System	8	
Valve Kit	9	
Electrical Connections	10	
Water Supply and Drain	11	
Final Checklist	12	
Operation	13	
Component Description	18	
Maintenance and Cleaning	25-27	
PARTS LIST AND WIRING DIAGRAMS		1
(Printed in Yellow)		
PARTS LIST:		
Cabinet Assembly	3	
Potable Water and Drainage System	4	
Ice Dispensing System	5	
Air-Cooled Condenser Assembly	6	
Water-Cooled Condenser Assembly	7	
Elbow and Switch Assembly	8	
Freezer Assembly	9	
Drivemotor Assembly	10	
Compressor Assembly	11	
Bin Top Assembly	12	
Control Box Assembly	13	
WIRING DIAGRAMS:		
HQD550AE-1C (115/60/1)	14	
HQD550WE-1C (115/60/1)	15	

**THIS PAGE
INTENTIONALLY
LEFT BLANK**

HQD550 GENERAL INFORMATION AND INSTALLATION

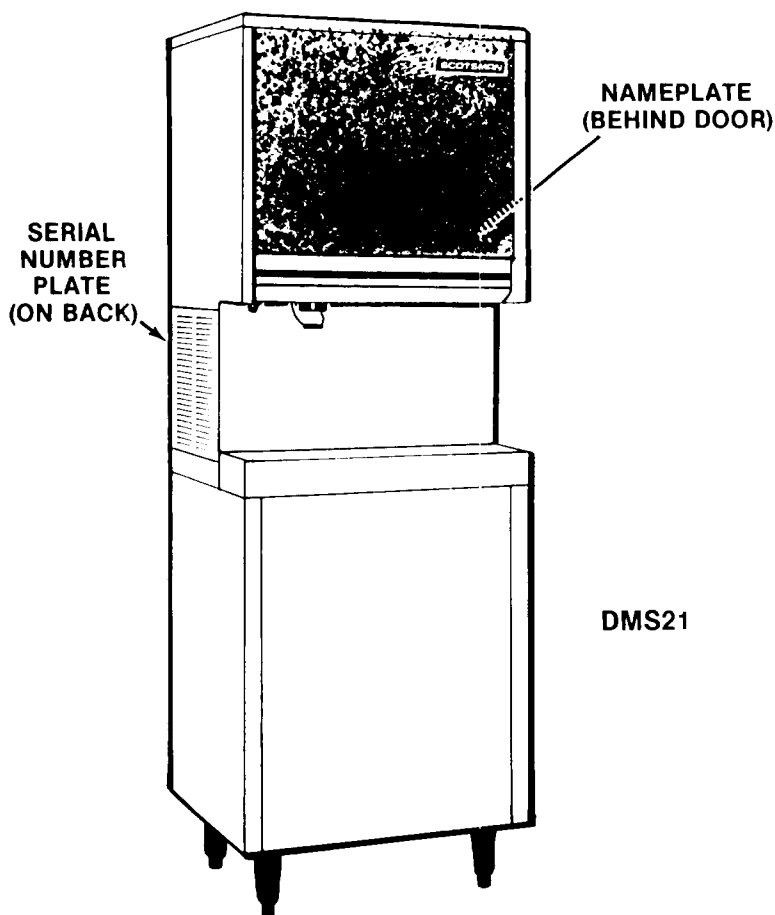

INTRODUCTION

This manual provides the specifications and the step-by-step procedures for the installation, start-up and operation, and the maintenance and cleaning for the SCOTSMAN HQD550 high quality ice dispenser.

DESCRIPTION



This attractive compact cabinet has textured metal with a sandalwood enamel finish, cork pattern vinyl upper front panel and sienna accent trim. Also, an optional stainless steel cabinet finish is available. Both cabinets have up-to-date styling, and easily removable panels for easy access to electrical and mechanical components.

SELF-CONTAINED STORAGE BIN

These high quality ice dispensers store their own ice supply in a cylindrical insulated ice storage bin.

NAME PLATE

MODEL NUMBER					
SERIAL NUMBER					
A.C. SUPPLY VOLTAGE			WIRES		
MINIMUM CIRCUIT AMPACITY			HERTZ		
MAXIMUM FUSE SIZE *			PHASE		
HEATER WATTS			CHARGE	OZ	
REFRIGERANT			RLA / FLA	WH.P.	L.R.A
MOTORS	VOLTS				
COMPRESSOR					
FAN					
DRIVE					
OTHER					
DESIGN PRESSURE			LOW	HIGH	
* OR HACR TYPE CIRCUIT BREAKER					

SCOTSMAN

SERIAL NUMBER PLATE

MODEL NUMBER		
SERIAL NUMBER		
VOLTS/HERTZ/PHASE		
MAXIMUM FUSE SIZE		
REFRIGERANT	CHARGE	OZ

This product qualifies for the following listings



This icemaker has been engineered to our rigid safety and performance standards. The National Sanitation Foundation (NSF) seal, signifies that it is listed with the NSF and that it complies with the materials and construction standards of the NSF. In addition, the Underwriters Laboratories, Inc., (UL) Listing Mark and the Canadian Standards Association (CSA) Monogram, both signify that its construction and design have been inspected and tested by them. NSF, UL and CSA inspectors also periodically examine production icemakers at the factory, to assure continued compliance.

To retain the safety and performance built into this icemaker, it is important that installation and maintenance be conducted in the manner outlined in this manual.

HQD550 FOR THE INSTALLER

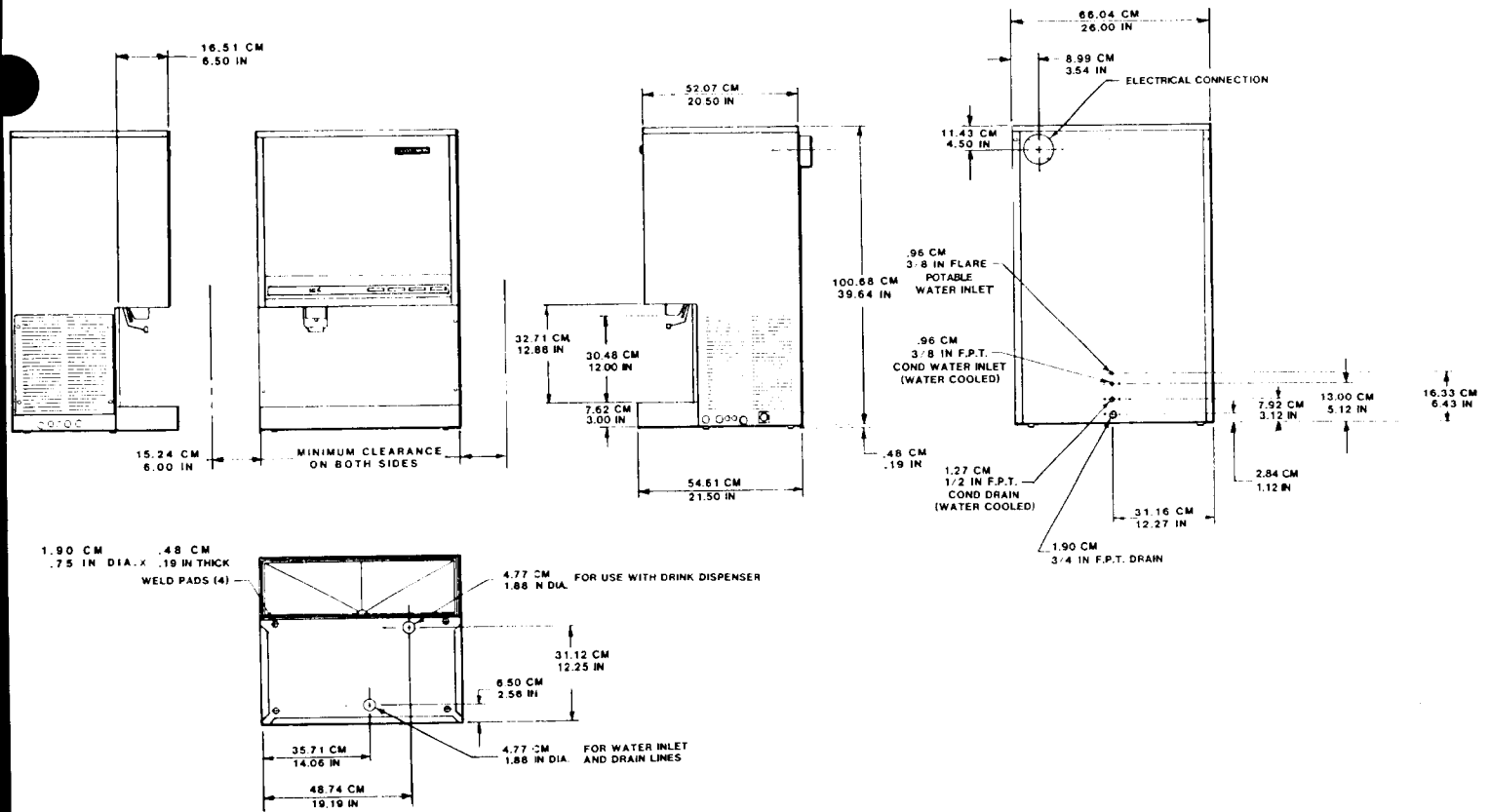

We reserve the right to make product improvements at any time. Specifications and design are subject to change without notice.

SPECIFICATIONS

Model Number	(Height - w/o Legs) Dimensions H" x W" x D"	Bin Cap.	Cube Size	Cond. Unit	Finish **	Basic Electrical	Comp. H.P.	No. of Wires	Min. Circuit Ampacity †	* Max. Fuse Size	Ship. Wt. lbs./kg.
HQD550AE-1C	39 ³ / ₈ x 26 x 21 ¹ / ₂	20 lbs	Nugget	Air	ES	115:60:1	1/2	2	17.9	20	270/122
HQD550AS-1C	39 ³ / ₈ x 26 x 21 ¹ / ₂	20 lbs	Nugget	Air	SS	115:60:1	1/2	2	17.9	20	270/122
HQD550WE-1C	39 ³ / ₈ x 26 x 21 ¹ / ₂	20 lbs	Nugget	Water	ES	115:60:1	1/2	2	17.3	20	270/122
HQD550WS-1C	39 ³ / ₈ x 26 x 21 ¹ / ₂	20 lbs	Nugget	Water	SS	115:60:1	1/2	2	17.3	20	270/122

** (SS) Stainless Steel

** (ES) Sandalwood. Leathergrain embossed steel with high gloss baked enamel finish

† Use this value to determine minimum wire size as per National Electric Code Standards

★ Or HACR type circuit breakers.

IMPORTANT OPERATING REQUIREMENTS

	MINIMUM	MAXIMUM
Air Temperatures	50°F (10.0°C)	100°F (38°C)
Water Temperatures	40°F (4.4°C)	100°F (38°C)
Water Pressures	20 lbs. gauge	120 lbs. gauge
Single Voltage Units	-10%	-10%

(Voltage rating specified on nameplate)

Extended periods of operation exceeding these limitations constitutes misuse under the terms of Scotsman Manufacturer's Limited Warranty, resulting in a loss of warranty coverage.

DMS21A Machine Stand: Available in baked enamel or stainless steel finish. 26-inches wide, 21-1/2-inches deep, 30-inches high — add 6-inches to height when optional legs are installed.

KSP1 Splash Panel Kit: For use when sink assembly is not used, covers sink mounting.

KV5H-30A: Four valve drink head for use with a remote carbonation system. Offers a choice of four soft drinks, carbonated water and non-carbonated water.

KWGF: Hardware and instructions to install water dispensing system. Can not be used with KV5H-30A.

OPTIONAL WALL MOUNTING KIT KWB3: For use when mounting on wall.

HQD550 FOR THE INSTALLER

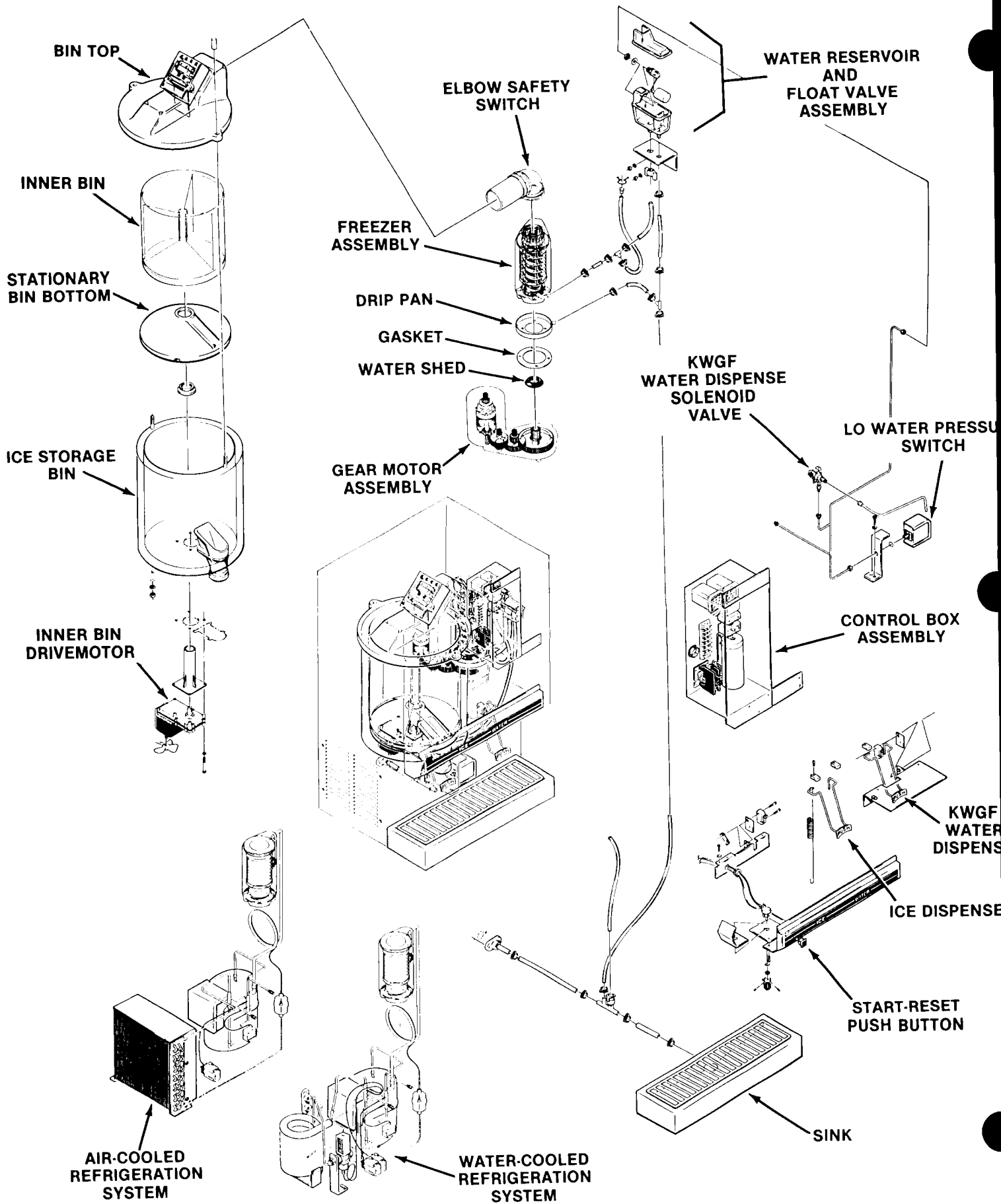

HQD550 FOR THE INSTALLER

LOCATION AND LEVELING

CAUTION

This icemaker is NOT designed for outdoor installations where air temperatures are below 50-degrees F., or above 100-degrees F., and water temperature is below 40-degrees F. or above 100-degrees F. Extended periods of operation at temperatures exceeding these limitations will constitute misuse, under the terms of the SCOTSMAN Manufacturer's limited warranty, resulting in LOSS of warranty coverage.

Prior consideration for location site shall include:

Minimum room temperature 50-degrees F.
Maximum room temperature 100-degrees F.

Water inlet temperatures:

Minimum 40-degrees F.
Maximum 100-degrees F.

Well ventilated location for air-cooled model, advising user to frequently clean air-cooled condenser, located directly behind the front service panel.

SERVICE ACCESS: Adequate space for all service connections, located at the rear of the cabinet. A six-inch minimum clearance at the rear and both side panels, for routing cooling air drawn into the air-cooled condenser and exhausted out the right side panel to maintain proper condensing operation of the air-cooled condenser.

1. Position the HQD550 dispenser in the permanent location.
2. Level the HQD550 dispenser in both the left-to-right and front-to-back directions.

The HQD550 "feet" fit into the DMS21A matching holes in the machine stand.

1. Remove shipping tape and packing.
2. Lay machine stand on back or side and install leg kit, if ordered.
3. Position machine stand in selected permanent location and level from front-to-back and side-to-side directions with the open section to the back.

Apply a 1/4" wide (minimum) bead of silicone sealant outlining the base of the dispenser (do not include the sink) to the top of the machine stand or counter as shown.

4. Set dispenser onto machine stand, tabs on the bottom of the dispenser match indentations and holes in the machine stand.
5. Wipe cabinet clean using damp cloth.

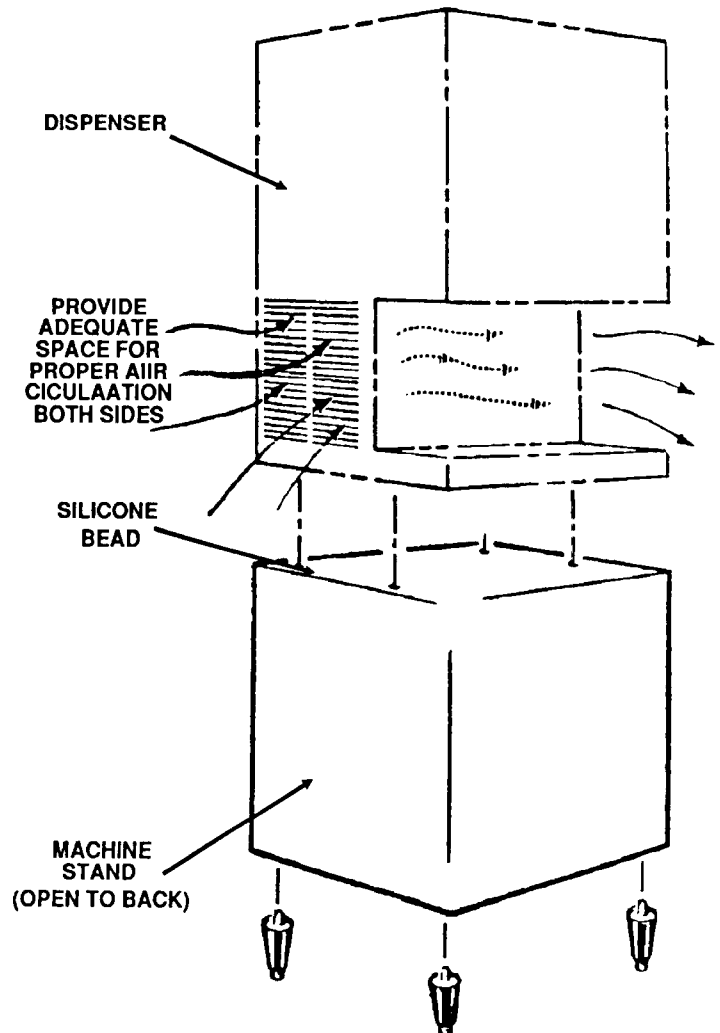

HQD550 FOR THE INSTALLER

KWB3 WALL MOUNT INSTRUCTIONS

//////////////////// WARNING //////////////////////

We recommend the wall mounting installation be done by an experienced contractor. The weights of the machines when in use are over 350 lbs. They should be mounted on a solid, rigid wall with proper fasteners for that type of wall and of adequate strength to support the weight of the machine during operation.

////////////////////////////////////

Clearance between wall and icemaker is a maximum of 1 inch.

A 6" minimum clearance is required at both sides of icemaker for airflow. (Air-cooled models)

Utility connection considerations include:
Removal of junction box.
Routing of plumbing connections and electrical source.

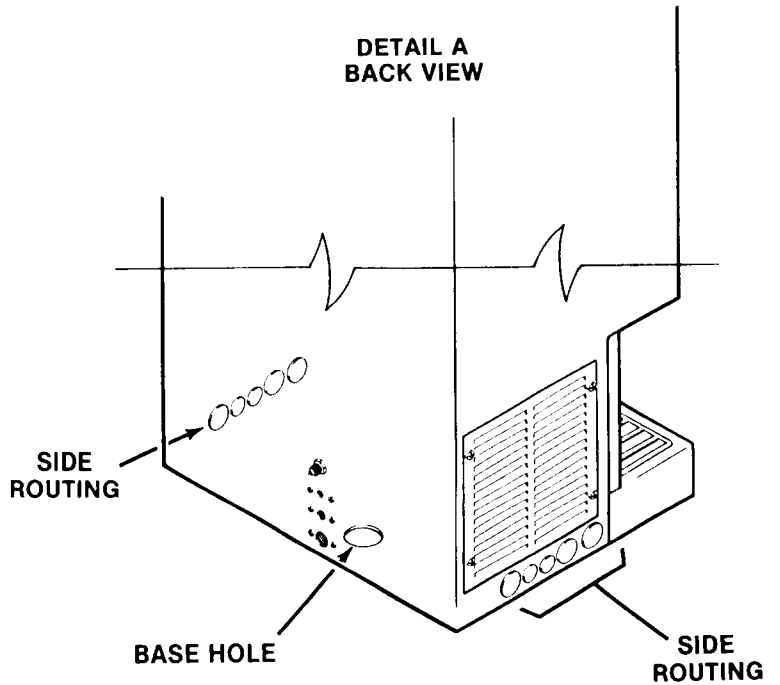
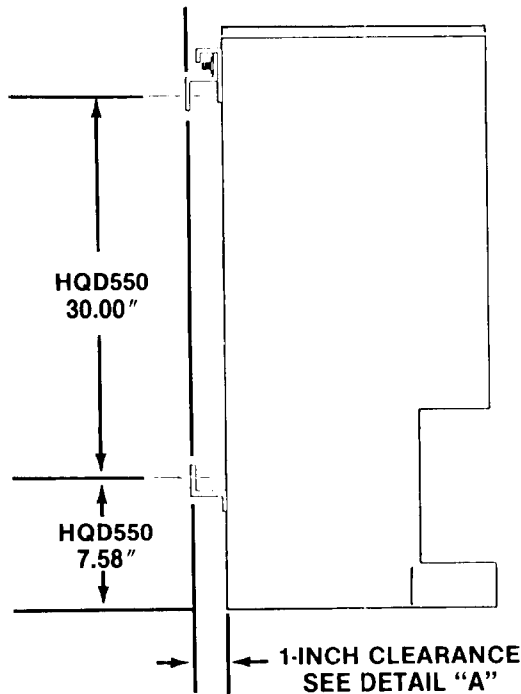

Utility connections may be made through the base or at either side through the pre-punched and plugged holes, using standard plumbing and electrical practices. See Detail A.

Interior plumbing lines must be disconnected from the original connections when routing utility connections through the side or base of icemaker.

HQD550 FOR THE INSTALLER

KWB3 WALL MOUNTING INSTRUCTIONS (Continued)

(See WARNING)

1. Remove machine top. Attach bracket "A" to machine using (3) nuts, (3) flat washers, (3) lockwashers and (3) 5/16-18 bolts received with kit.
2. Mount brackets "B" and "C" to wall at dimensions shown for specific unit. (Hardware for this not included.)

*USE FASTENERS AND WALL OF SUFFICIENT STRENGTH TO CARRY THE USE AND WEIGHT OF THE ICEMAKER.

3. Lift unit up and hook bracket "A" over bracket "B". Slide unit until the two remaining holes are aligned and secure with remaining (2) 1/4-20 bolts, (2) flat washers and (2) lockwashers.

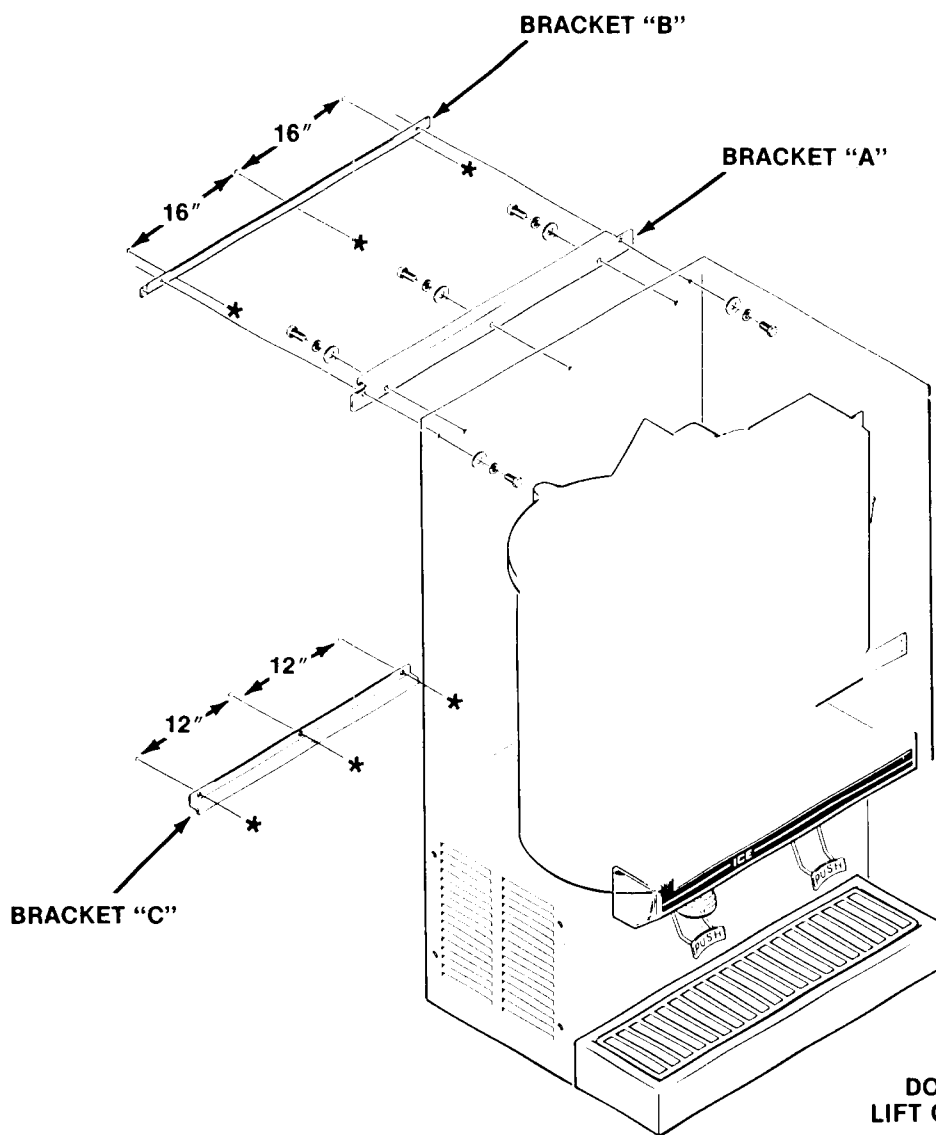

HQD550 FOR THE INSTALLER

INSTALLATION INSTRUCTIONS KWGF WATER DISPENSING SYSTEM

CAUTION

Shut off potable water supply to HQD550 icemaker at shut-off valve.

WARNING

Before proceeding with installation, disconnect all electrical power to HQD550.

1. Remove two screws, push up to unsnap catches and remove cabinet top panel.
2. Remove two screws, pull out to unsnap catches and remove cabinet front panel.
3. Remove screws and remove cabinet splash panel.
4. Remove screws and remove filler plate from icemaker dispenser and scrap.
5. Locate water solenoid valve assembly in kit contents and attach the (2) red wires shipped with kits contents, to the solenoid terminals.
6. Locate in kit contents, the water line assembly and water line adapter and connect to water solenoid valve. Fitting sizes will determine location.
7. Remove plug from potable water line to prepare to connect to water inlet solenoid valve connecting tubing.
8. Install valve plate and switch assembly to dispenser, replacing filler plate removed and scrapped in step 4.
9. Attach water solenoid assembly to underside of upper compartment using (2) screws, #10 Helical Spring Lockwashers into threaded holes provided.
10. Attach water line adapter and solenoid valve assembly to water line where plug was removed in step 7.
11. Attach clamp and #8-32x3/4 Phillips recess pan head machine screw to install water line assembly to the dispenser.
12. Insert Glass Filler Lever through square slot in valve plate and switch assembly and attach to dispenser with (2) arm clamps and (2) #6-32x1/2 panhead machine screws.
13. See that glass filler lever pushes micro-switch actuator.
14. Attach glass filler lever spring to glass filler lever. Observe spring ends, large hook to filler lever, small hook to hole directly below in dispenser base.
15. Attach red wire connected to the solenoid to the switch on the valve plate assembly. Attach the blue wire to the switch on the valve plate. Route red wire connected to the solenoid and blue wire connected to the valve plate switch to the control box. Attach red wire to the bottom terminal of the terminal strip and attach the blue wire to the second from the bottom terminal of the terminal strip.

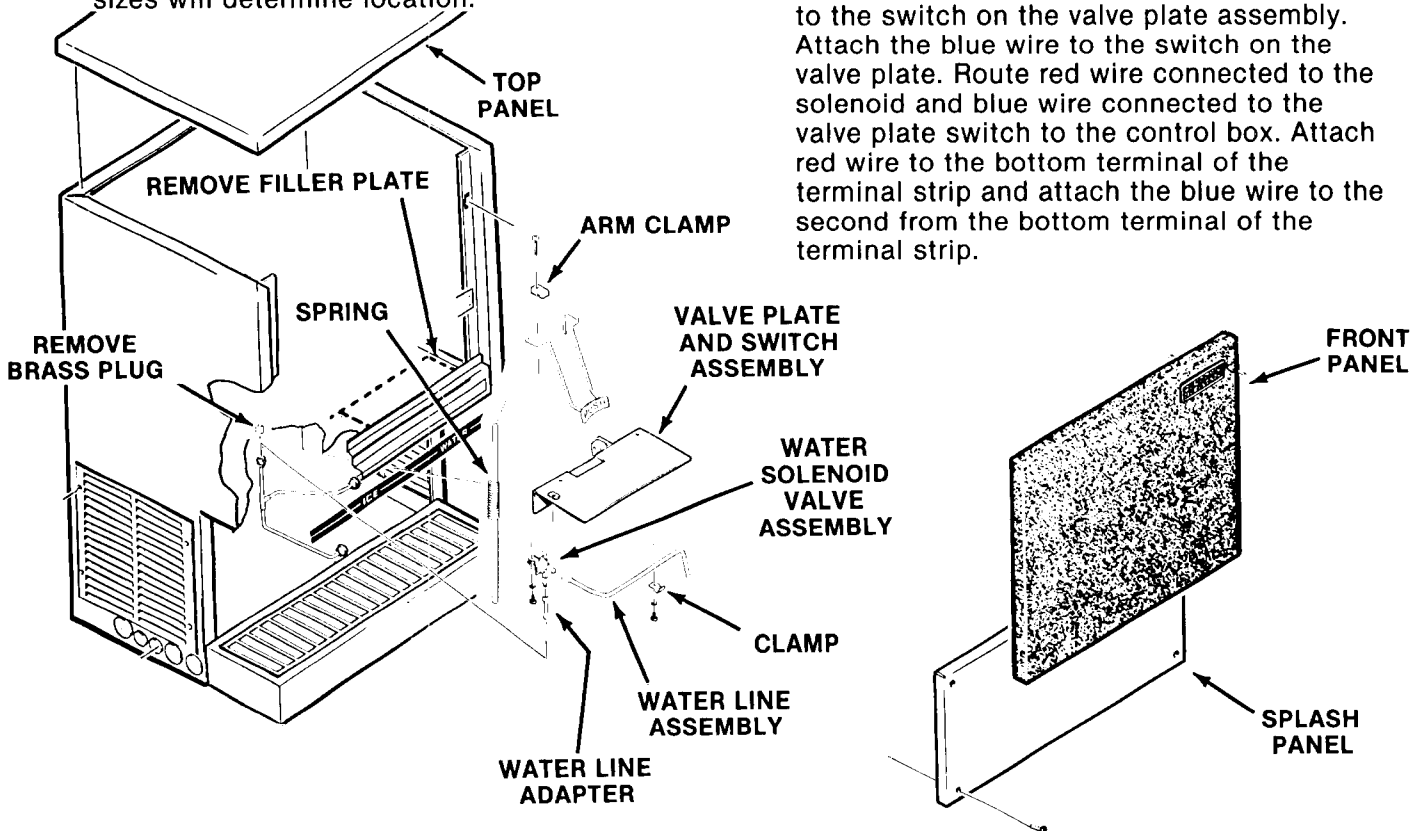

HQD550 FOR THE INSTALLER

INSTALLATION INSTRUCTIONS KV5H-30A VALVE KIT TO HQD550 FOR USE WITH A CARBONATION SYSTEM.

////////// WARNING //////////

Before proceeding with installation, disconnect all electrical power to HQD550.



1. Remove cabinet top panel, front panel and splash panel to prepare to install drink valve kit.
2. Remove screws and remove filler plate from icemaker dispenser.
3. Remove plug button from base of ice machine.

4. Install valve assembly in the ice machine with two screws through the same holes that held on valve cover plate. Install 1-3/8" I.D. insulation tube covering over syrup and carbonated lines.
5. Route product lines through hole in base of unit.
6. Bundle all carbonated water lines and product lines together and cover with a good insulating tubing, (lines and insulating tube to be supplied by customer). Connect these lines to the valve kit lines making sure all product lines and connections are insulated. A carbonated water recirculating line is provided and recommended, this insures that high quality drinks are dispensed.
7. Install transformer in HQD550 upper compartment base using screws provided, it may be necessary to pre-drill holes.
8. Route drink valve head electrical leads up into the upper compartment to 24v Class II transformer location.
9. Connect wire leads from drink valves to 24 volt output side of transformer.
10. Locate a 115 volt continuous power source from within the icemaker control box. Route white and black wire leads from 115 volt input side at transformer and connect to 115 volt power source.

NOTE: Carbonator and carbonated product cooling system must be field supplied.

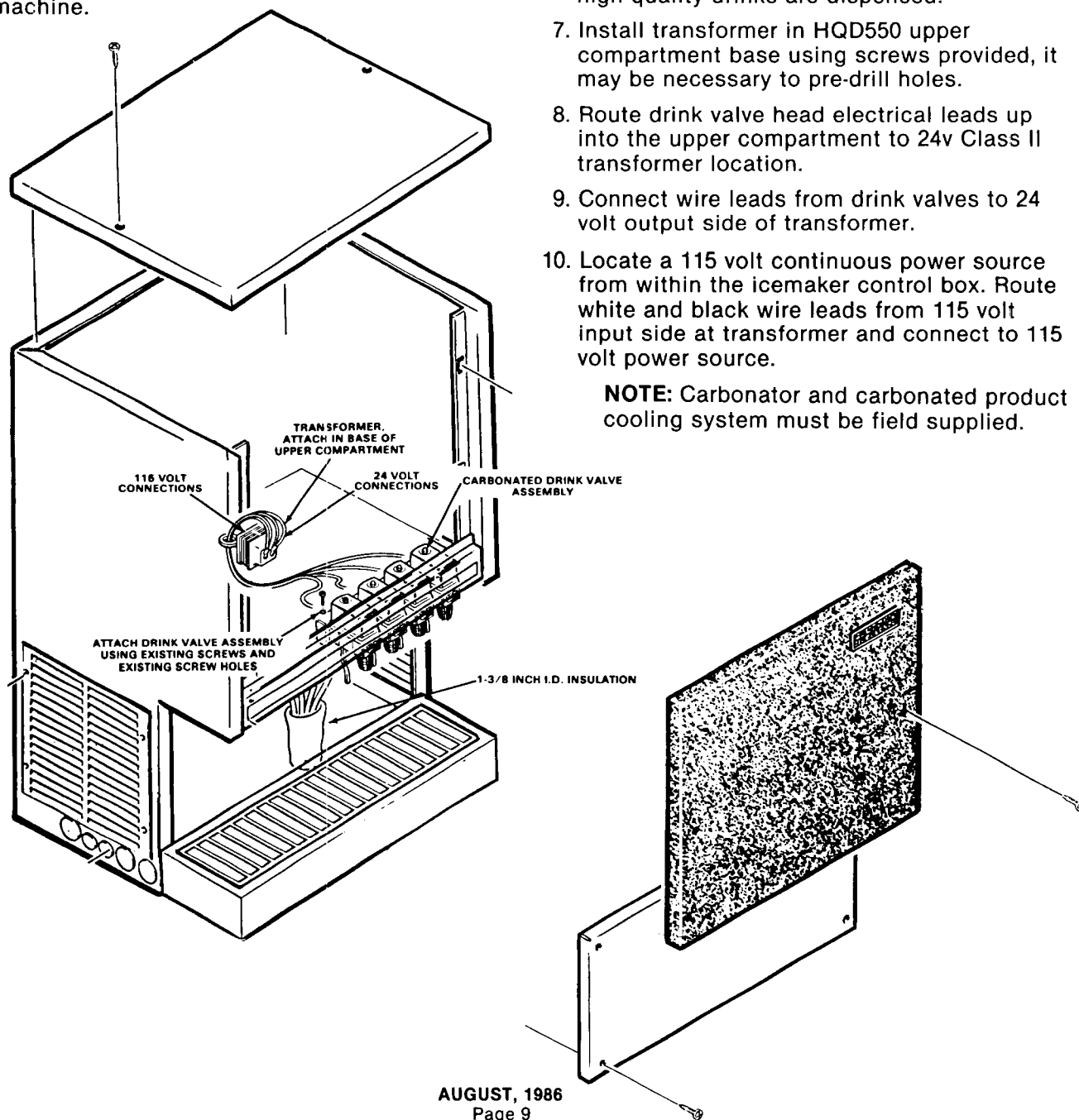

HQD550 FOR THE ELECTRICIAN

ELECTRICAL CONNECTIONS

//////////////////// WARNING //////////////////////

This icemaker requires a **SOLID EARTH GROUND** that meets the national, state and local electrical code requirements. To prevent possible **SEVERE ELECTRICAL SHOCK INJURY** to individuals, or extensive damage to equipment, install an approved **SOLID EARTH GROUND** wire to this icemaker. SEE wiring diagram.

////////////////////////////////////

SEE NAMEPLATE for current requirements to determine wire size to be used for electrical hookup.

Be certain the dispenser is connected to its own electrical circuit and individually fused. The maximum allowable voltage variation should not exceed ten percent of the nameplate rating, even under starting conditions. Low voltages can cause erratic operation and may be responsible for serious damage to the overload switch and motor windings.

All external wiring should conform to the national, state and local electrical code requirements. Usually an electrical permit and services of a licensed electrician will be required.

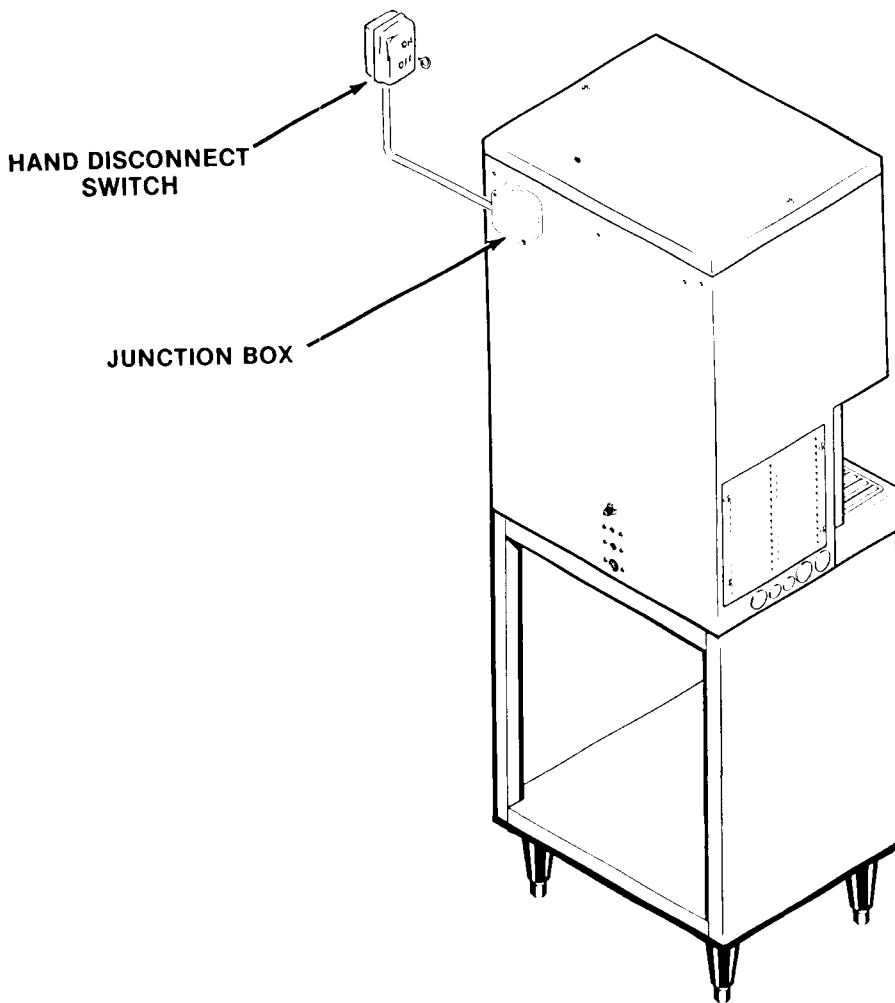

HQD550 FOR THE PLUMBER

WATER SUPPLY AND DRAIN CONNECTIONS

1. AIR-COOLED MODELS: The recommended water supply line is a 3/8 inch O.D. copper tubing. Connect to cold water supply line with standard plumbing fittings with a shutoff valve installed in an accessible place between the water supply and the dispenser.

A wire mesh optional strainer is available, and when used, must be installed with the cleanout plug down. Locate the strainer in the water supply line, next to the dispenser with the arrow on the strainer, in the direction of the water flow. The strainer protects against large particles of rust, scale, etc., which may be loosened in the water supply pipe at the time of installation.

CAUTION

This icemaker is equipped with a low water pressure safety device which in the event of low water pressure will automatically stop the icemaker to prevent damage. The icemaker will automatically restart with increased water pressure.

2. WATER-COOLED MODELS: On water-cooled models a separate connection to the condenser is required. A 3/8 inch O.D. copper tubing is recommended for a separate water inlet line and a 1/2" O.D. separate drain line.

NOTE: The CAUTION in the text for the Air-Cooled models equally applies for the Water-Cooled models. In both type installations, water supply must be installed to conform with local plumbing codes. In some cases, a plumbing permit and services of a licensed plumber will be required.

3. DRAIN CONNECTIONS: All drains are gravity type and must be 1/4-inch fall per foot on horizontal runs. Drains are to be installed to conform with local code. The drain receptacle should be an open, trapped, or vented construction.

Recommended bin drain is 3/4-inch O.D. copper tubing. It should be vented and run separately. Run a separate drain line to 1/2-inch O.D. drain tube from the Water-Cooled Condenser on Water-Cooled models.

4. Insert sink drain tube into dispenser drain tube located in the center bottom of the dispenser. Secure drain tube with hose clamp and snap sink into tabs located on the dispenser base. Drop grill into sink.

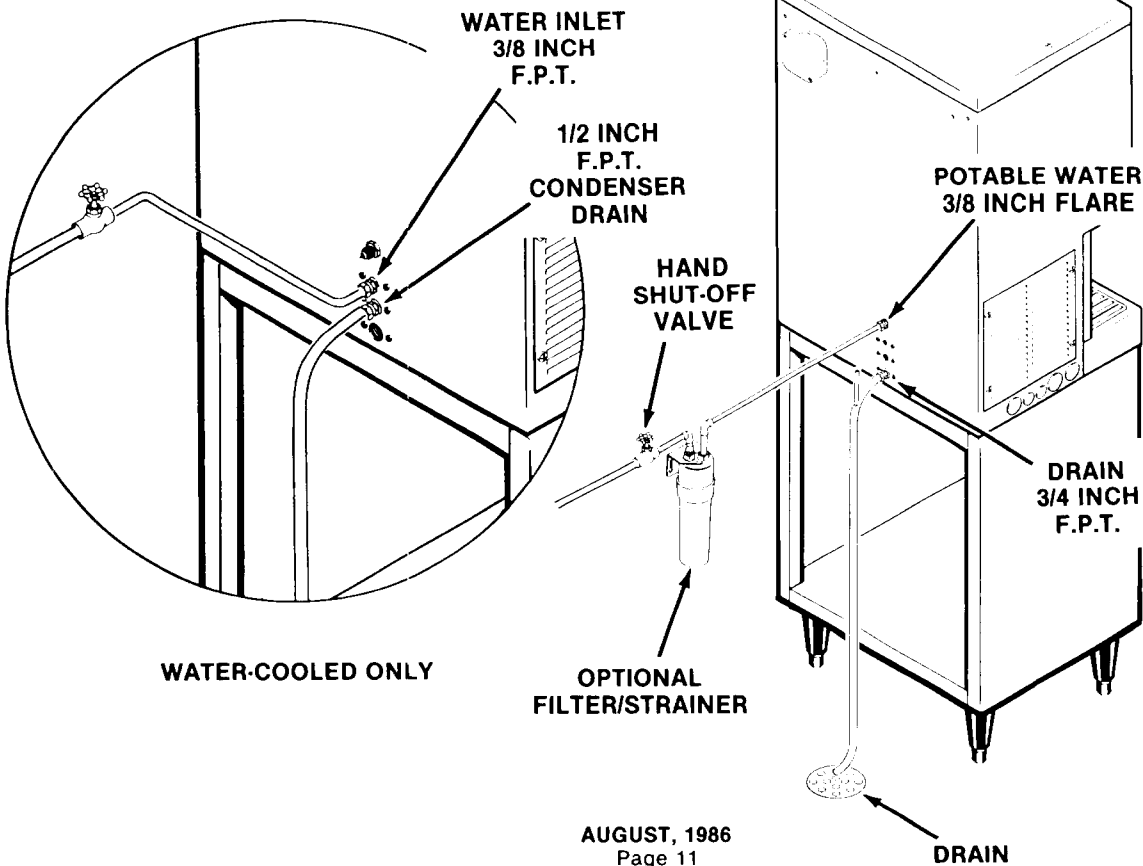

HQD550 FOR THE INSTALLER

FINAL CHECK LIST

1. Is the Dispenser level? (IMPORTANT)
2. Is the Dispenser in a room where ambient temperatures are a minimum of 50-degrees F. all year around?
3. Is there at least a six-inch clearance behind and around the cabinet for all connections and for proper air circulation?
4. All shipping tape removed from panels, doors, styrofoam blocks, etc?
5. Have all electrical and piping connections been made?
6. Has the electrical power supply wiring been properly connected, and the voltage tested and checked against the nameplate rating?
7. Has proper Chassis-to-earth ground been installed?
8. Is the water supply line shut-off valve installed and opened and has the inlet water supply pressure been checked to ensure a minimum of 20 PSIG?
9. Have the Compressor hold down bolts been checked to be sure the compressor is snug on the mounting pads?
10. Check that the Bin Ice Level and Bin Ice Level safety switches work.
11. Check that air flow from the air-cooled condenser does not return and recirculate into the condenser. A baffle may have to be fabricated behind the machine to prevent this recirculation problem.
12. Have the Dispenser and the Bin been wiped clean with clean damp cloths?
13. Has the owner/user been given the User Manual and instructed on how to operate the icemaker and the importance of periodic maintenance?
14. Has the owner/user been given the name and telephone number of the Authorized SCOTSMAN Distributor or Service Agency serving him?
15. Has the Manufacturer's Registration Card been properly filled out? Check for correct Model and Serial Numbers from nameplate, then mail the completed card to the SCOTSMAN factory.

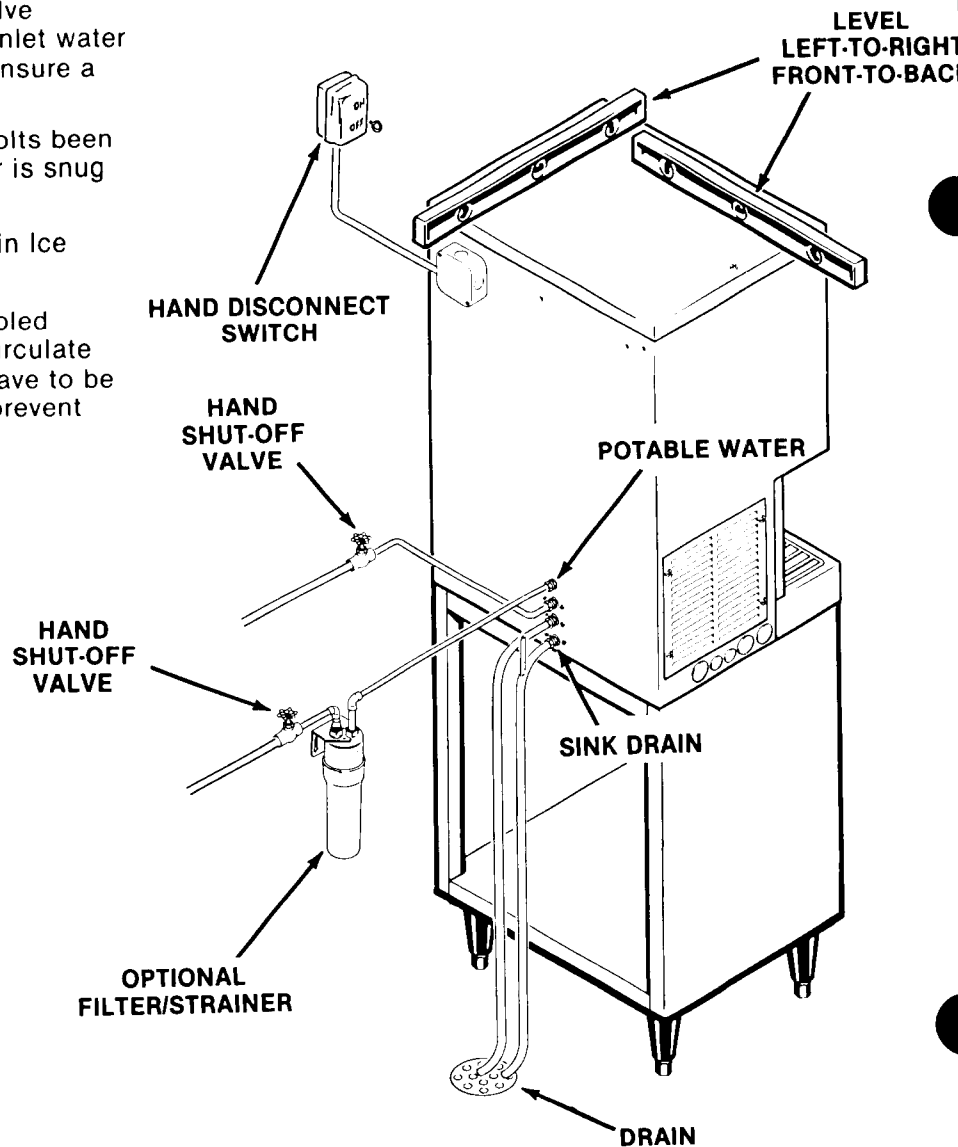

HQD550 START-UP

START UP

1. Remove two screws and push UP to unsnap catches and remove the top panel.
2. Remove two screws and pull OUT to unsnap catches and remove front panel.
3. Remove screws and back splash panel.
4. OPEN the inlet water supply line shut-off valve.
5. Observe the water filling operation.
 - a. Water flows into water reservoir.
 - b. Float moves up as water rises.
 - c. Water flows through the water feed line to the bottom of the freezer assembly.
 - d. Float STOPS water flow when level reaches 3/8-inches below the molded horizontal line on the body of the water reservoir.
6. Connect electrical power to ON position.
7. Press the illuminated START-RESET pushbutton to START the automatic ice making process. Listen for the sound the compressor start-up.
8. After four or five minutes of operation, observe that random lengths of cylindrical broken chunks of high quality ice begins dropping out of the open end of the ice spout, above the cylindrical ice storage bin.
9. Let the system operate for about 30 minutes or, until ice fills about one-fourth of the bin. Check for any excess noises beyond normal compressor noise:
 - a. Fan noises, Air-Cooled: Blades touch other surfaces; blades bent, or out-of-balance.
 - b. Vibrating type: From touching lines.
 - c. Chattering: Lack of water in freezer.
 - d. Compressor loose at one or more holddown bolts.
10. Rotate the ice portion control knob, on the front of the switch mount, fully CLOCKWISE, to the section labeled MAXIMUM.
11. With an ice drink glass, push IN on the glass filler level assembly, under the ice spout, and check that DESIRED amount of ice is dispensed.
12. After a few seconds, RELEASE pressure on the glass filler lever assembly and check that ice dispensing STOPS.
13. Rotate the ice portion control knob, on the control panel, to about MID-RANGE on the dial; then, with a standard ice drink glass, push IN on the glass filler lever assembly, under the ice spout, and observe that a measured amount of ice is dispensed and dispensing STOPS.
14. Check the ice portion dispensed in the glass to determine whether the amount of ice is:
CORRECT ICE PORTION
TOO SMALL ICE PORTION
TOO LARGE ICE PORTION
15. Rotate the ice portion control knob, CLOCKWISE, about one-eighth of a turn, to INCREASE the ice portion; or, COUNTER-CLOCKWISE, about one-eighth of a turn, to DECREASE the ice portion.
16. Dispense several ice portions, in the glass to be used for standard example, and repeat steps to achieve the desired correct portion.
17. Check the bin ice level switch.

NOTE: The bin ice level switch is an ON-OFF switch, that shuts OFF the compressor to stop icemaking, while the freezer assembly drivemotor continues to operate, in order to clear all ice from the auger. Then, when the refrigerant pressure equalizes, a refrigerant lo-pressure control will shut OFF the drivemotor. When the ice flow pushes the actuator arm of the switch IN, the compressor is shut OFF and when the action of the melting or dispensed ice releases the actuator arm, the switch CLOSES the circuit and RESTARTS the compressor and the icemaking process.

The bin ice level safety switch is mounted next to bin ice level switch and is actuated by the movement against the switch actuator. The safety switch acts as a backup safety switch, should the bin ice level switch fail and cause ice to jam up in the ice spout. The safety switch will shut off the icemaker only when actuated. It is an immediate and complete shut down of the entire icemaker. The bin ice level safety switch must be manually reset.
18. Thoroughly explain to the owner/user the significant specifications of the icemaker, the start up and operation, going through the procedures for the operating instructions. Answer all questions about the icemaker, by the owner; and, inform the owner of the name and telephone number of the authorized SCOTSMAN Service Agency serving him.

HQD550 START-UP

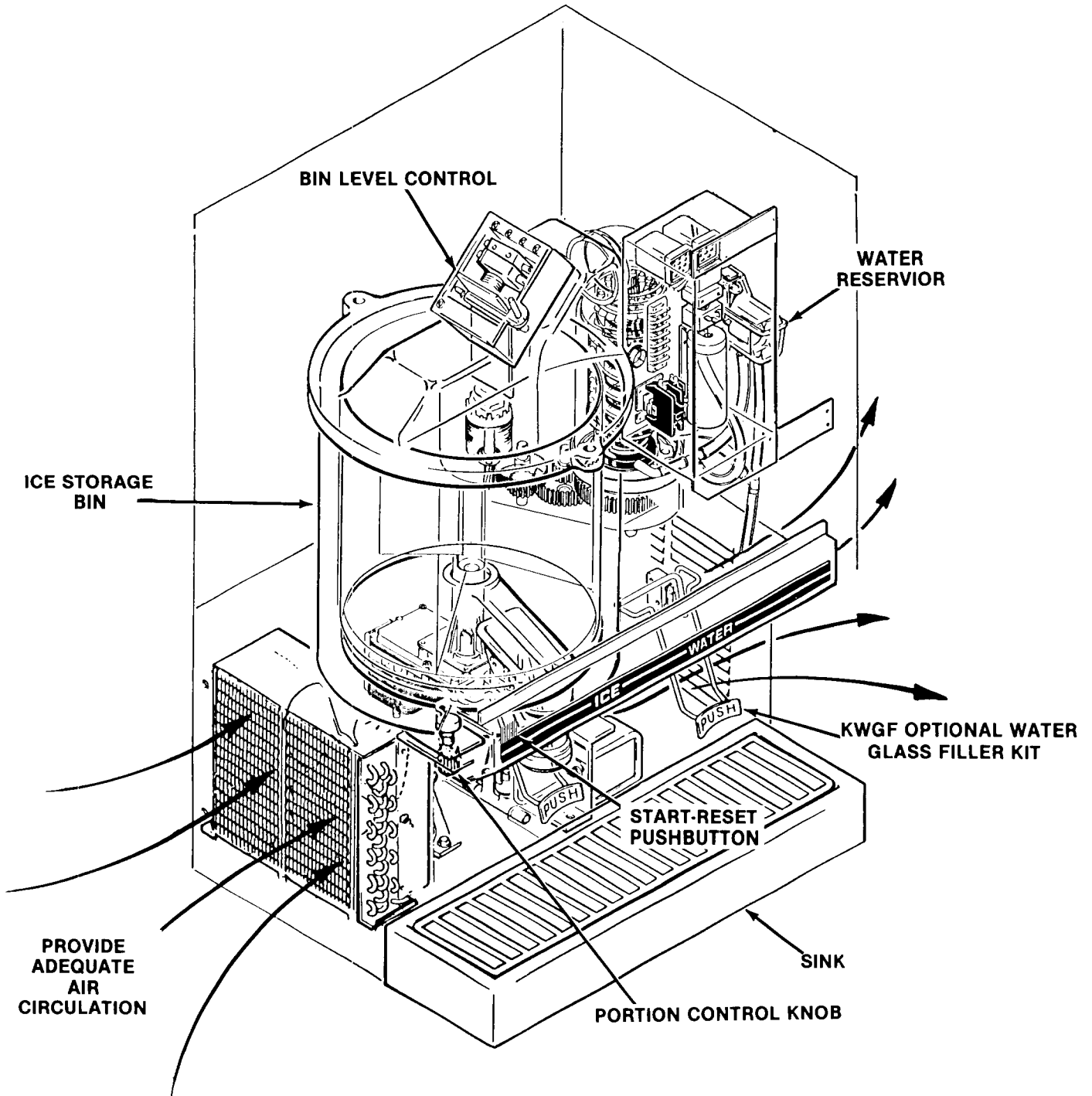

HQD550 OPERATION

DISPENSING SYSTEM

STANDBY—In the STANDBY mode, the refrigeration system is in automatic operation, ice is being made and dispensed into the cylindrical ice storage bin, or the bin is full and the refrigeration system is shutdown. The electrical circuit in the dispensing control circuit has an ice vend switch and an ice portion timing module, both in the N/O position.

ICE DISPENSE—With a container, push in a glass filler lever and dispense ice, the circuit is completed through the ice vend switch and the ice portion timing module and the bin drive motor, which causes ice to be dispensed. Then one of the two sequences next occur:

1. After a complete vend has been made the ice portion timing module removes power, which OPENS the circuit to the bin drive motor and STOPS the ice dispensing, and returns the circuit to the STANDBY condition.
2. When the container is removed, before a complete vend has been made, releasing the glass filler lever assembly, power is interrupted through the ice vend switch, which STOPS the ice dispensing, and returns the circuit to the STANDBY condition.

KWGF OPTIONAL WATER GLASS FILLER KIT

WATER DISPENSE—With a container, push in glass filler lever and dispense water, the circuit is completed through the water vend switch to the coil of the water solenoid, which energizes the coil and OPENS the water solenoid valve allowing a flow of water to be dispensed.

When the container is removed, releasing the glass filler lever assembly, the circuit through the water vend switch OPENS, interrupting power to the coil of the water solenoid; which de-energizes the coil and CLOSES the water solenoid valve, shutting OFF the flow of water being dispensed.

With an ice drink glass, pitcher or container, push IN on the glass filler lever assembly, under the water spout, and check that water is CONTINUOUSLY dispensed.

After a few seconds, RELEASE pressure on the glass filler lever assembly and check that water dispensing STOPS.

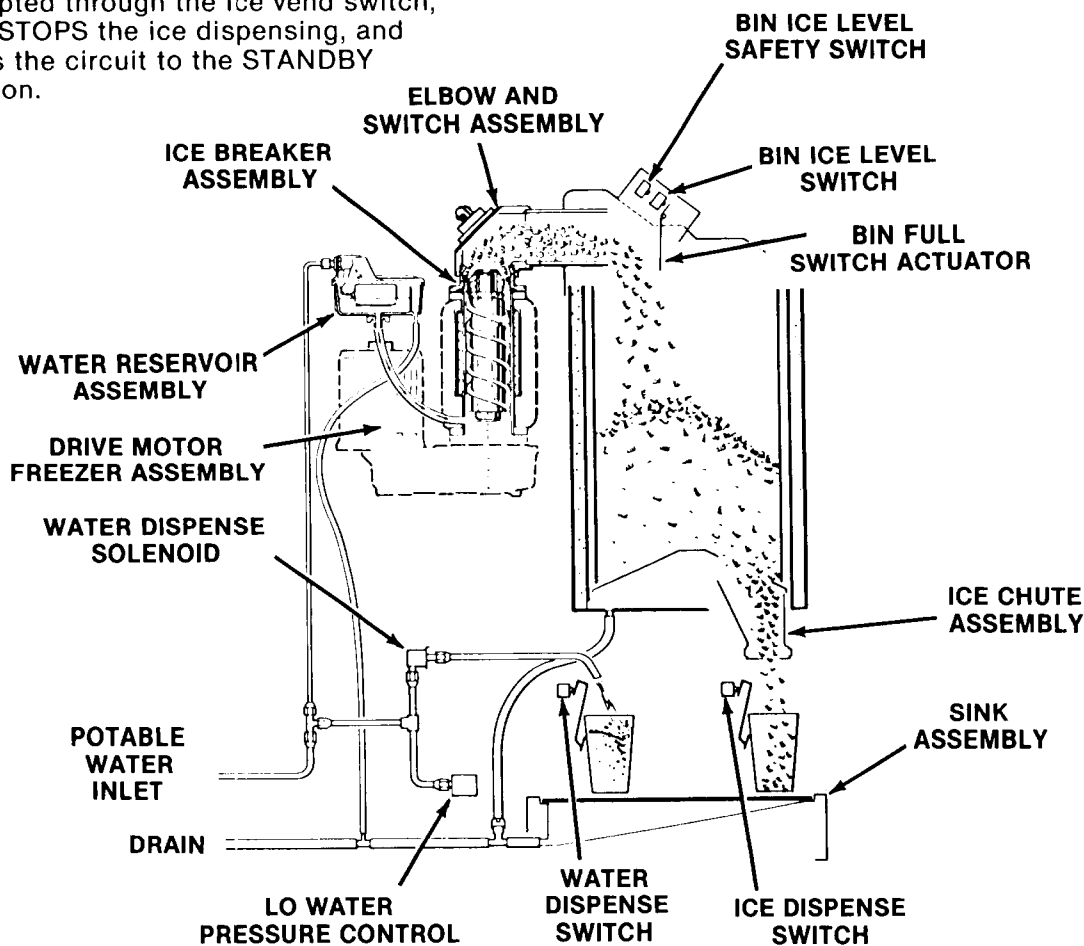

HQD550 OPERATION

ICEMAKER

The water supply flows from the building source through the inline water strainer, enters the cabinet and on to the water reservoir. The water reservoir functions to maintain a constant water level inside the freezer assembly. Water from the water reservoir enters at the bottom of the freezer assembly and is changed into ice by low temperatures inside the freezer.

A stainless steel auger within the freezer is powered by the drivemotor assembly, a direct-drive gearmotor, and the rotating auger carries the ice upward to the end of the auger, where excess water is pressed out of the ice, as it is extruded and broken into random length chunks of ice and pushed out through the ice spout and into the ice storage bin.

Connecting electrical power starts the automatic and continuous icemaking process. When the cylindrical ice storage bin has been filled with ice, up to the level of the bin ice level switch actuator, the actuator depresses the bin ice level switch and shuts off the icemaking process.

As the ice is removed from the cylindrical ice storage bin, the actuator releases the bin ice level switch restarting the automatic icemaking process.

ELECTRICAL/REFRIGERATION

The Model HQD550 Dispensers are designed to operate on standard electrical supply 115 volts, 60 Hertz, single phase.

Therefore, always **CHECK NAMEPLATE** for electrical information **BEFORE** proceeding with electrical wiring connections to the icemaker.

Cold ambient temperatures and interruptions in water supply are conditions that can cause excessively hard ice and overloads within the freezer assembly, which is directly transmitted to the drivemotor; and in turn, will cause speed reduction or ultimate freezeup.

When the drivemotor is slowed to a predetermined RPM, a sensing switch mounted on top of the motor is designed to open the electrical circuit to the compressor. The compressor stops operating, no more ice is produced, and the drivemotor continues to operate, rotating the auger to clear the overload and gradually building up to full speed.

At a pre-determined higher RPM drivemotor speed, the speed sensing switch closes the electrical circuit to the compressor, causing the normal icemaking process to resume.

Refer to the appropriate Wiring Diagram and trace circuitry and control functions, as described in the following paragraph:

As shown on all SCOTSMAN wiring diagrams, the controls are in the ICEMAKING MODE. Thus, the 1-2 contacts are CLOSED. At START-UP, the 1-2 contacts are OPEN and the 3-2 contacts are CLOSED. As the icemaker begins to operate, the low side pressure starts to decrease from the stabilized or at-rest pressure. As soon as the pressure is reduced to 20 PSIG, the 3-2 contacts OPEN and the 1-2 contacts CLOSE.

This removes the operating controls, such as the bin ice level switch, from the gearmotor circuit. If one of the operating controls OPENS, it will SHUT OFF the compressor circuit. The gearmotor will operate until the low side pressure increases to 32 PSIG. Then, the 1-2 contacts OPEN and SHUT OFF the gearmotor, usually within one or two minutes, depending upon ambient conditions. This brief period of time allows the auger to transport all the ice out of the freezing chamber. Consequently, when called on to STARTUP again, there is no ice load to start up against. Again, on STARTUP, the 1-2 contacts are OPEN and the 3-2 contacts are CLOSED.

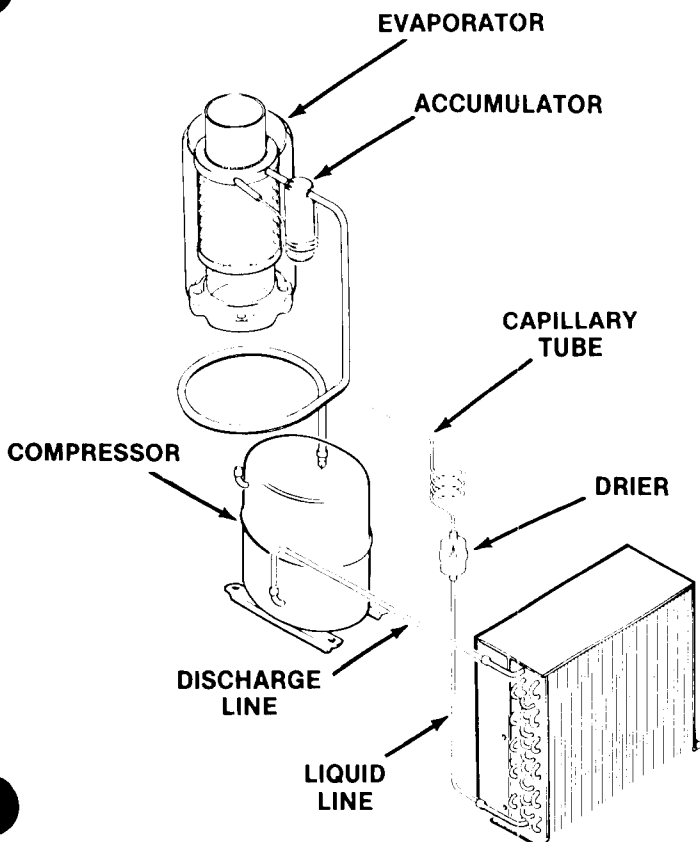

HQD550 COMPONENT DESCRIPTION

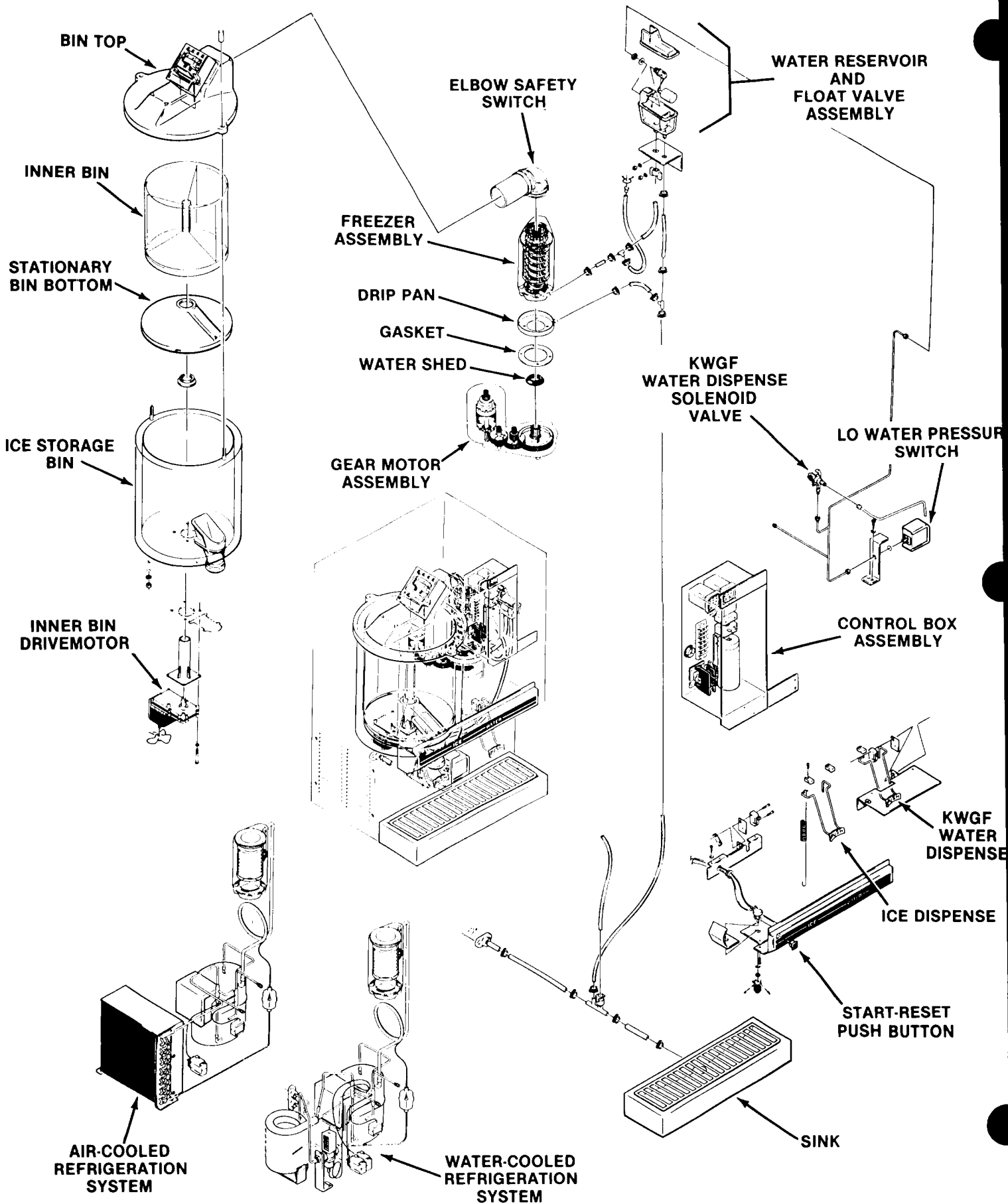

HQD550 COMPONENT DESCRIPTION

BIN ICE LEVEL SAFETY SWITCH

The bin ice level safety switch is mounted next to bin ice level switch and is actuated by the movement against the switch actuator. The safety switch acts as a backup safety switch, should the bin ice level switch fail and cause ice to jam up in the ice spout. The safety switch will shut off the icemaker only when actuated. It is an immediate and complete shut down of the entire icemaker. The bin ice level safety switch must be manually reset.

BIN TOP

The bin top assembly protects the ice supply and provides a mount for the bin ice level switch and the bin ice level safety switch.

BIN ICE LEVEL SWITCH

The bin ice level switch is an ON-OFF switch, that shuts OFF the compressor to stop icemaking, while the freezer assembly drivemotor continues to operate, in order to clear all ice from the auger. Then, when the refrigerant pressure equalizes, the refrigerant low-pressure control will shut OFF the drivemotor. When the ice flow pushes the actuator arm of the switch IN, the compressor is shut OFF and when the action of the melting or dispensed ice releases the actuator arm, the switch CLOSSES the circuit and RESTARTS the compressor and the icemaking process.

The proper cut in position of the bin ice level switch is when the bin fill switch actuator arm is hanging straight down.

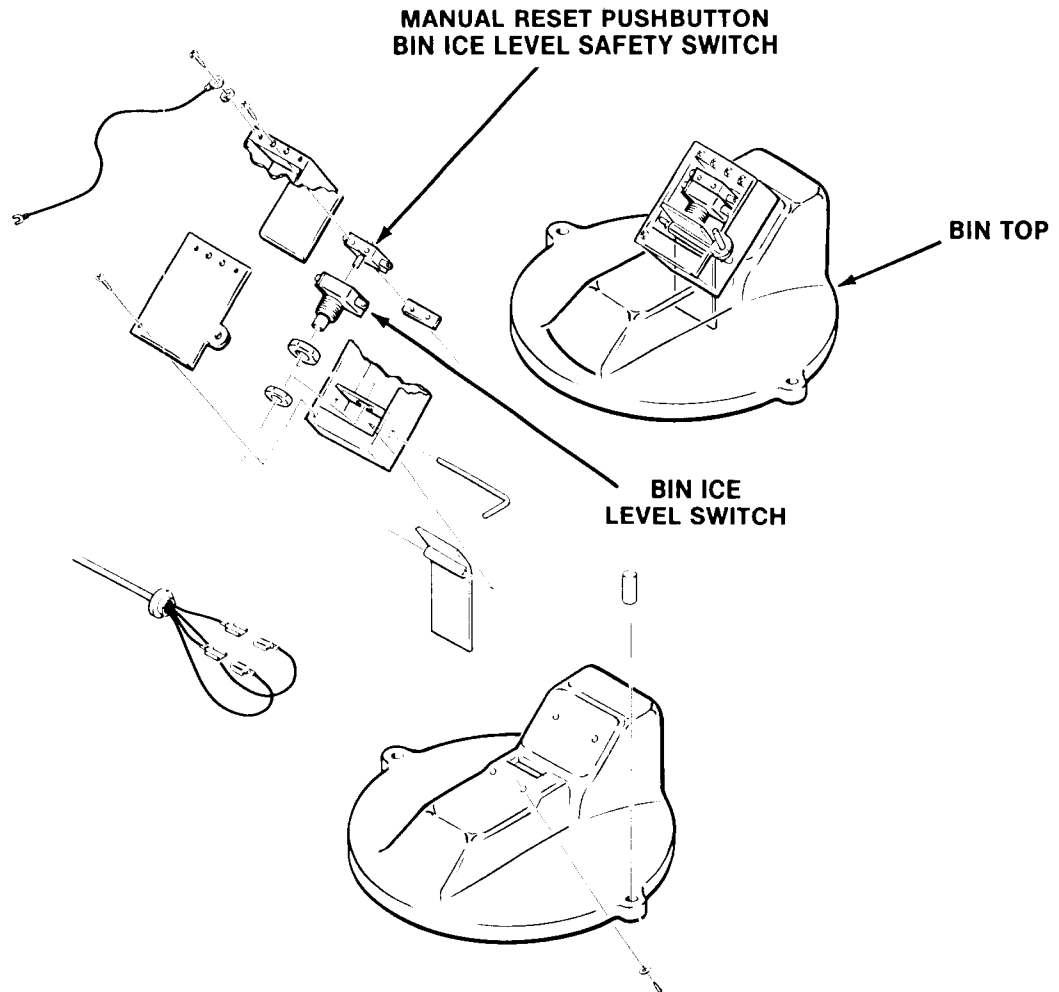

HQD550 COMPONENT DESCRIPTION

There are additional SAFETY CONTROL DEVICES within the HQD550 that protect the machine from expensive damage and down time.

WATER PRESSURE SAFETY SWITCH installed in the potable water inlet line is set to electrically open at zero to four PSIG and stop the entire icemaker. The **AUTOMATIC RESET** will restart the icemaking process when water pressure rises to 20 PSIG.

AUGER DELAY SWITCH, a single-pole double throw (SPDT) switch, allows the gearmotor to rotate the Auger and clear the freezing chamber after the bin ice level switch circuit to compressor is OFF. When the icemaker restarts, the gearmotor starts in a no load condition, preventing excessive loading of gearmotor and bearings.

REFRIGERANT LO PRESSURE CONTROL is factory set to automatically SHUT DOWN the icemaker if the low-side pressure drops below 4 PSIG or low ambient or water temperatures exist. This is a **AUTOMATIC RESET** control.

Water-cooled icemakers have two refrigerant pressure switches, hi refrigerant pressure and low refrigerant pressure.

ELBOW SAFETY SWITCH

The elbow safety switch is an ON-OFF switch that shuts off the compressor when an ice jam presses against the rubber diaphragm depressing the switch and opening the circuit. Melting action relieves pressure closing the circuit, lighting the start-reset pushbutton. The start-reset switch must then be pressed to start the automatic icemaking process.

ICE BREAKER ASSEMBLY

The ice breaker assembly, bolted to the top of the freezer, contains the bearing and seal for the top of the auger. Flaked ice created by the freezer is carried by the auger to the ice breaker assembly and the flaked ice is pushed by the auger through the tapered holes in the ice breaker. Flaked ice is compressed by auger pressure as it is pushed through the ice breaker assembly and the shafts of compressed ice are broken into random lengths of Ice Nuggets by the taper on the top of the ice breaker.

WATER REGULATOR VALVE WATER-COOLED MODELS

The water regulator valve functions to maintain a constant head pressure, by regulating the amount of incoming water flow through the condenser, on water-cooled models. The valve operates through the refrigerant system high side pressure. Rotating the adjusting screw, located on top of the valve, can INCREASE or DECREASE the operating head pressure.

HQD550 COMPONENT DESCRIPTION

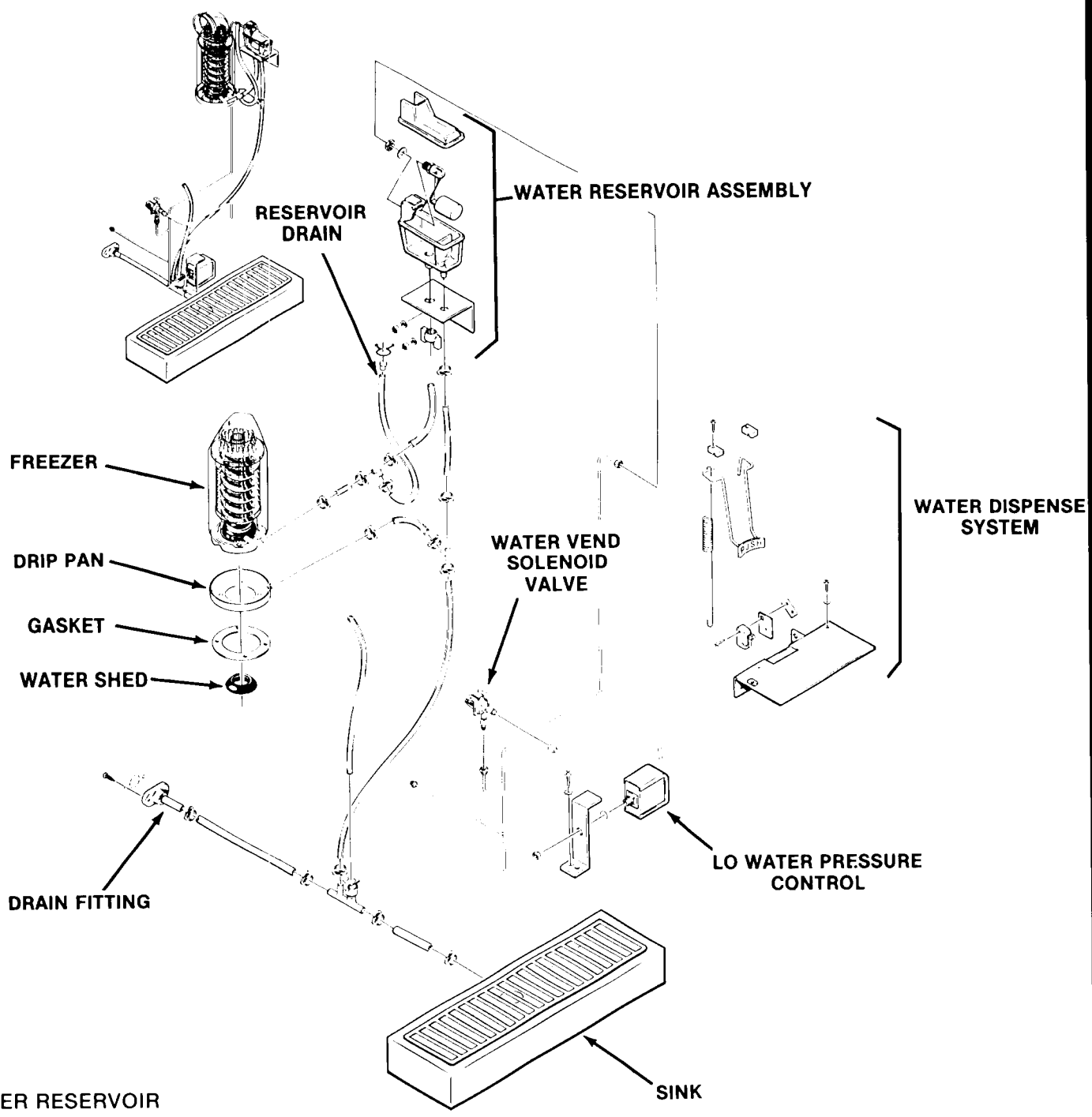

WATER RESERVOIR

The water reservoir, with a float valve assembly, maintains a constant water supply within the freezer assembly. The water level in the reservoir is the same water level as in the freezer and the correct water level in the freezer is level with the top of the auger flights. The water level in the freezer can be adjusted by raising or lowering the water reservoir with the bracket.

RESERVOIR DRAIN

The reservoir drain is for use to drain the water reservoir when cleaning or maintenance of the icemaking system.

HQD550 COMPONENT DESCRIPTION

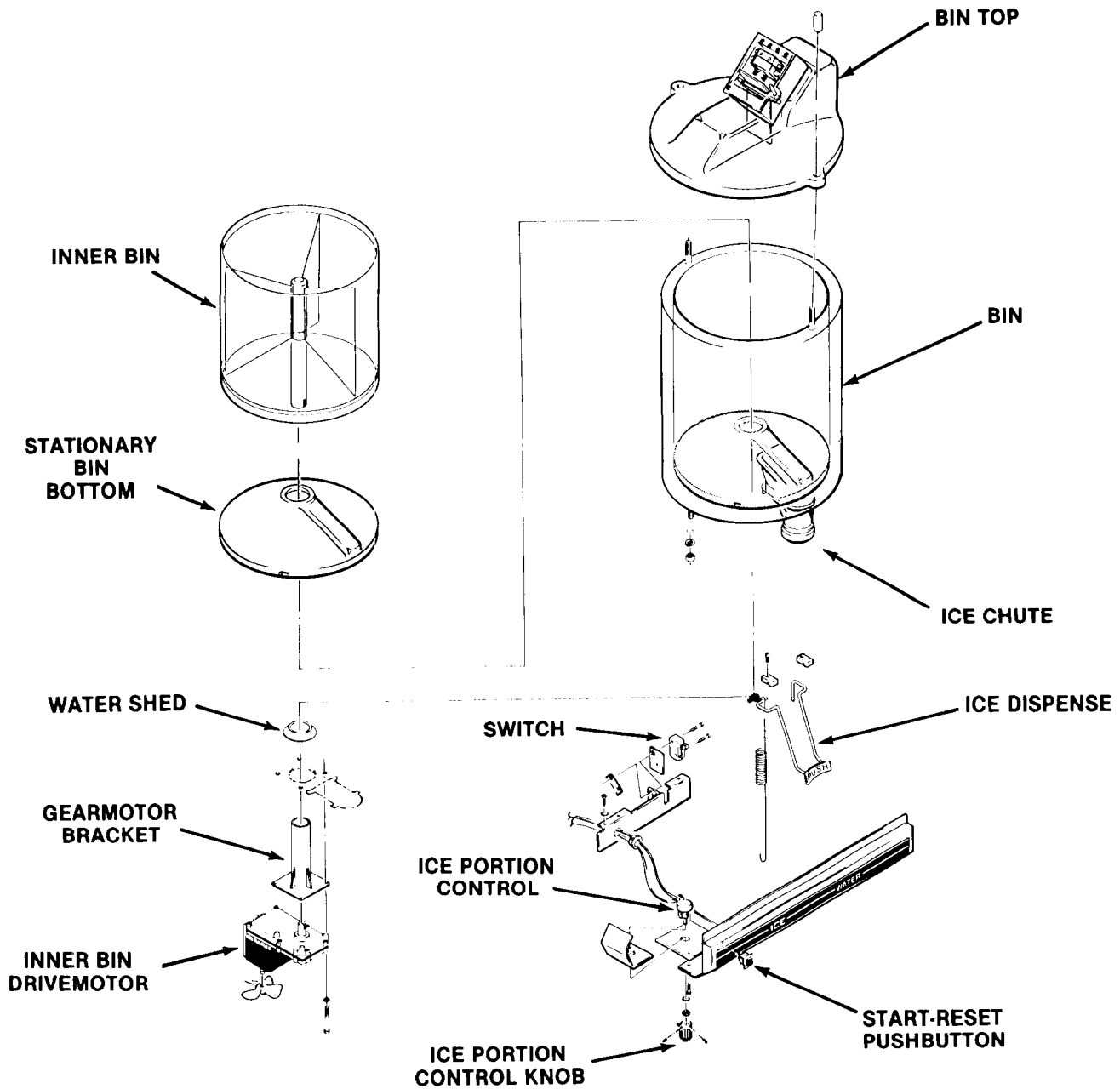

BIN BOTTOM

The cone shaped stationary bin bottom holds the ice supply, and when the inner bin is rotated the ice supply rotates and ice is shaved off from the bottom and drops, by gravity, through the ice dispense spout.

INNER BIN

Rotates when drivemotor is energized, causing ice pile to rotate over bin bottom, dispensing ice.

INNER BIN DRIVE MOTOR

The inner bin drive motor and reduction gear assembly, located below the bin, is controlled with the ice vend switch and portion control timing module. The inner bin drive motor rotates the inner bin and ice supply to vend a metered amount of ice into a container.

START-RESET PUSHBUTTON

When pushed completes the electrical circuit through the icemaker electrical components. The START-RESET PUSHBUTTON must be pressed to restart the icemaking process whenever any of the safety controls have functioned to stop the icemaker or an interruption in the electrical supply has occurred.

HQD550 COMPONENT DESCRIPTION

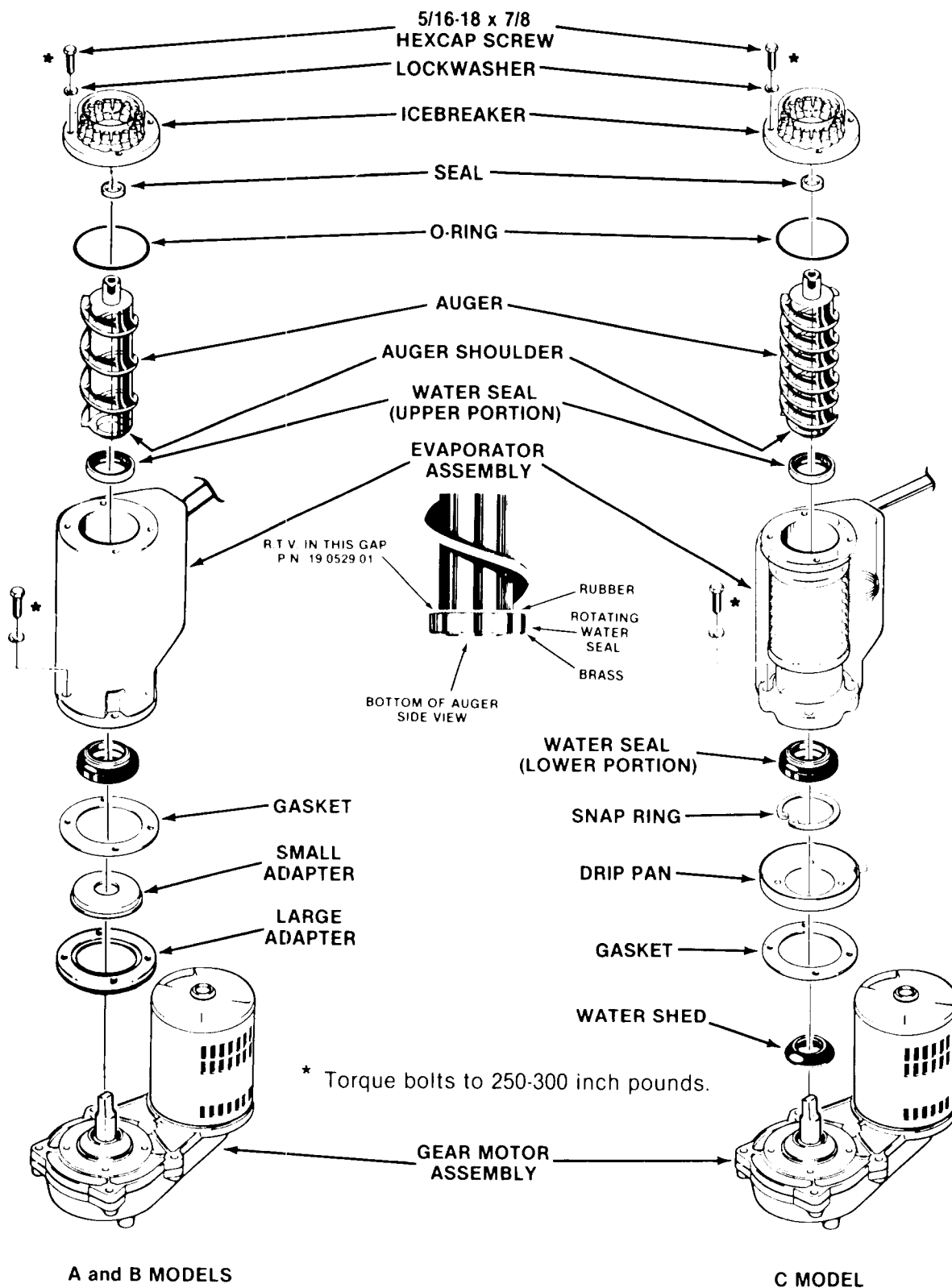

HQD550 COMPONENT DESCRIPTION

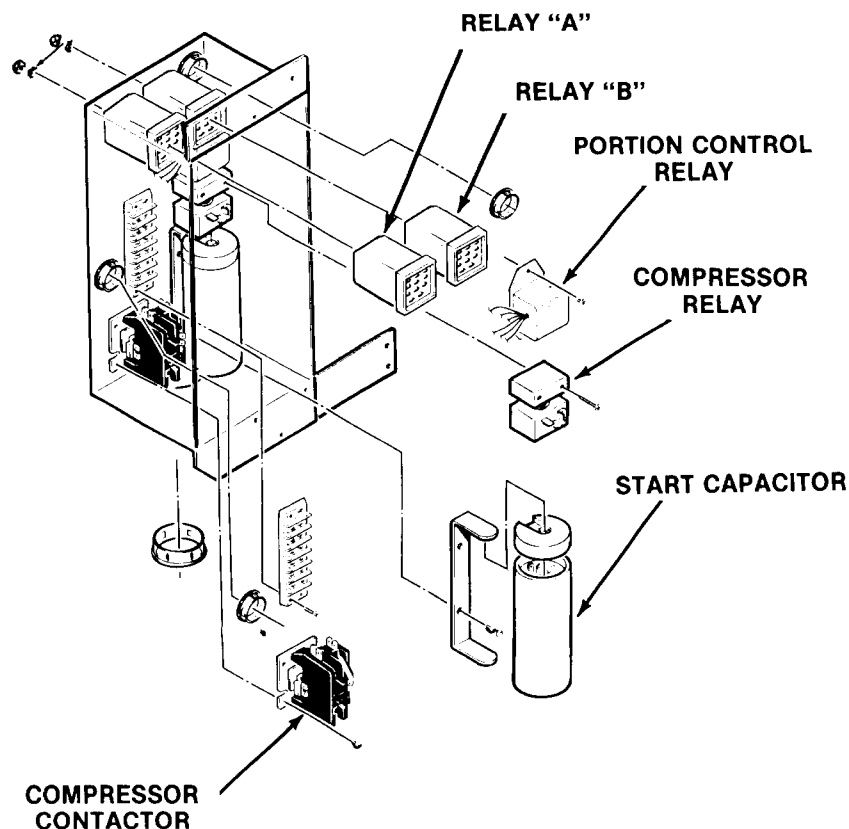

COMPRESSOR CONTACTOR

A single-pole contactor is used to supply current to the compressor; and, is wired so any control in the pilot circuit, such as the bin thermostat and high pressure control, etc., will cause the contactor coil to be de-energized, when the control contact OPENS, thereby breaking the circuit to the compressor through the contactor points.

ELBOW SAFETY SWITCH RELAY "A"

The elbow safety switch relay "A" maintains a circuit through the elbow safety switch until the elbow safety switch opens and switches the current through the lamp of the start reset pushbutton, which must be pushed and reset to restart the automatic icemaking process.

RELAY "B"

Relay "B" protects the compressor contactor from chattering during operation of the icemaking system.

COMPRESSOR START RELAY

The compressor start relay completes the circuit to the compressor from the start capacitor to provide enough energy to start the compressor. When the compressor motor has reached the proper RPM's, the compressor relay opens and removes the start capacitor from the circuit.

ICE PORTION CONTROL TIMING MODULE

The ice portion control timing module operates in conjunction with the ice portion control Potentiometer and times the run of the bin drive motor to meter the amount of ice dispensed. This system is adjustable from approximately 1/2 ounce to 6 ounces.

HQD550 MAINTENANCE AND CLEANING INSTRUCTIONS

////////////////////////////////////
A Scotsman Ice System represents a sizable investment of time and money in any company's business. In order to receive the best return for that investment, it MUST receive periodic maintenance.

It is the USERS RESPONSIBILITY to see that the unit is properly maintained. It is always preferable; and less costly in the long run, to avoid possible down time by keeping it clean, adjusting it as needed and by replacing worn parts before they can cause failure. The following is a list of recommended maintenance that will help keep your machine running with a minimum of problems. Maintenance and Cleaning should be scheduled at a MINIMUM of twice per year.

////////////////////////////////////
ICEMAKER

THE FOLLOWING MAINTENANCE SHOULD BE SCHEDULED AT LEAST TWO TIMES PER YEAR ON THIS ICEMAKER. CALL YOUR AUTHORIZED SCOTSMAN SERVICE AGENCY.

1. Check and clean water line strainers.
2. Check that the water level in the water reservoir is at the molded line on the side of the float.
3. Remove cover from water reservoir and depress the float to insure that a full stream of water enters the reservoir.
4. Check that the icemaker cabinet is level, in side-to-side and front-to-back directions.
5. Clean the water reservoir and interior of the freezer assembly, using a solution of SCOTSMAN Ice Machine Cleaner. Refer to CLEANING-Icemaker.
6. When doubtful about refrigerant charge, install refrigerant gauges on Schrader valves and perform steps 6 and 7. Check gauge for compressor head pressure:

AIR-COOLED MODELS: Varies between 130 and 145 PSIG.

WATER-COOLED MODELS: Set at 135 PSIG. Adjust screw on top of water regulator valve to raise or lower head pressure.
7. Check gauge for suction line pressure:

Varies around 18 PSIG, depending upon inlet water temperature and ambient air temperature.

AFTER SERVICING REFRIGERATION SYSTEM:
TORQUE REFRIGERATION ACCESS VALVE CAPS TO 60-75 INCH POUNDS.

8. Check drivemotor operation:

Oil motor once per year.

Normal operating temperatures are about 160-degrees F., which is hot to touch.

//////////////////////////////////// **WARNING** //////////////////////////////////////

Disconnect electrical power supply before removal procedures.

- ////////////////////////////////////
9. Check the elbow safety switch by removing the insulation halves, twisting the locking ring 90° and pulling out the switch assembly. The switch action can then be tested.

NOTE

The elbow safety switch is an ON-OFF switch that shuts off the compressor when an ice jam presses against the rubber diaphragm depressing the switch and opening the circuit. Melting action relieves pressure closing the circuit, lighting the start-reset pushbutton. The start-reset switch must then be pressed to start the automatic icemaking process.

10. Clean the air-cooled condenser, using vacuum cleaner, whisk broom or brush. Instruct customer to clean frequently and to be sure icemaker and fan motor are OFF.
11. Check that fan blades move freely, are not touching any surfaces and are not bent or out of balance.
12. Check for water leaks. Pour water down bin drain to be sure that drain line is open and clear.
13. Check the bin ice level switch.

NOTE

The bin ice level switch is an ON-OFF switch, that shuts OFF the compressor, when the ice pushes the actuator arm of the switch IN. When the pressure releases the actuator arm, the switch CLOSES the circuit and RESTARTS the icemaker process.

14. Check the spout safety switch.

NOTE

The spout safety switch is manual reset and functions to immediately STOP the icemaking process if the bin ice level switch were to fail and begin to cause ice to jam up in the spout.

HQD550 MAINTENANCE AND CLEANING INSTRUCTIONS

NOTE

If the unit being serviced is equipped with a STEEL NEEDLE bearing, the breaker assembly should be REPLACED. Contact your local Scotsman Distributor for further information. Breakers with a NON-METALLIC bearing should be cleaned and the seal replaced TWICE PER YEAR. If the type of breaker bearing is not known, the breaker should be inspected. All A and B models were equipped with steel needle bearings. Most C Models have the non-metallic bearings.

15. Remove elbow insulation and remove three Allen head screws and spout retaining brackets from the freezer assembly end of the elbow and switch assembly.
16. Remove three Allen head screws and spout retaining brackets from the freezer assembly end of the elbow and switch assembly.

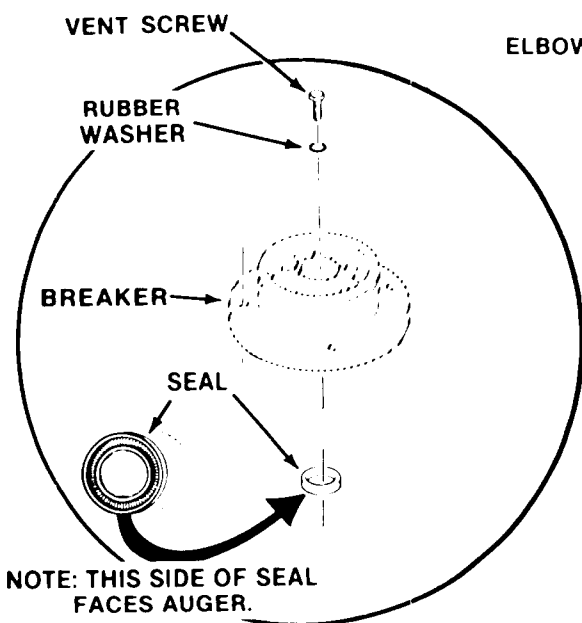

NOTE

In order to accomplish removal of the elbow and switch assembly in the next step, it may be necessary to further remove panels and disassemble the ice transport tube.

17. Lift the elbow and switch assembly and set aside to gain access to the top of the freezer assembly.
18. Remove four capscrews, lockwashers and the ice breaker assembly from the top of the freezer assembly for inspection.
19. Retain the O-ring for replacement during reassembly. Inspect the O-ring for cuts, tears or excessive wear, causes for replacement.

20. Replace the lip seal and inspect the top bearing seated in the ice breaker, wipe clean of mineral build up. Remove auger. Check seal and check auger for stains.

CAUTION

DO NOT force the auger and breaker together without having the vent hole open because pushing the breaker on with no air relief will cause the internal air pressure to force the grease seal away from the breaker.

INSULATION (Continued on pg. 27)

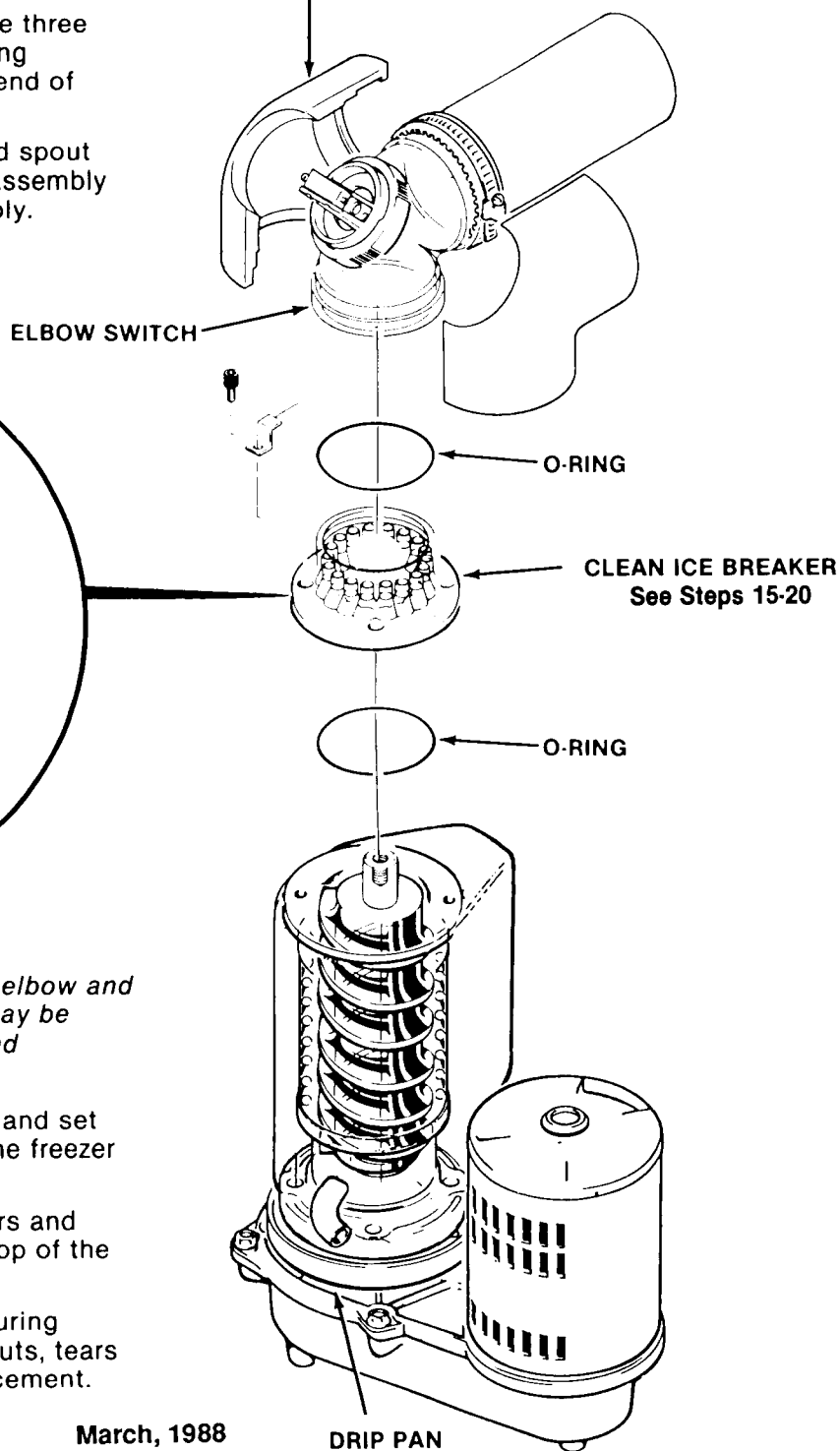

HQD550 MAINTENANCE AND CLEANING INSTRUCTIONS

CLEANING

1. Remove screws and push UP to unsnap catches and remove the top panel.
2. Remove screws and push OUT to unsnap catches and remove front panel.
3. Remove screws and back splash panel.
4. Remove screws and the left side panel.
5. Remove all ice from the cylindrical storage bin.

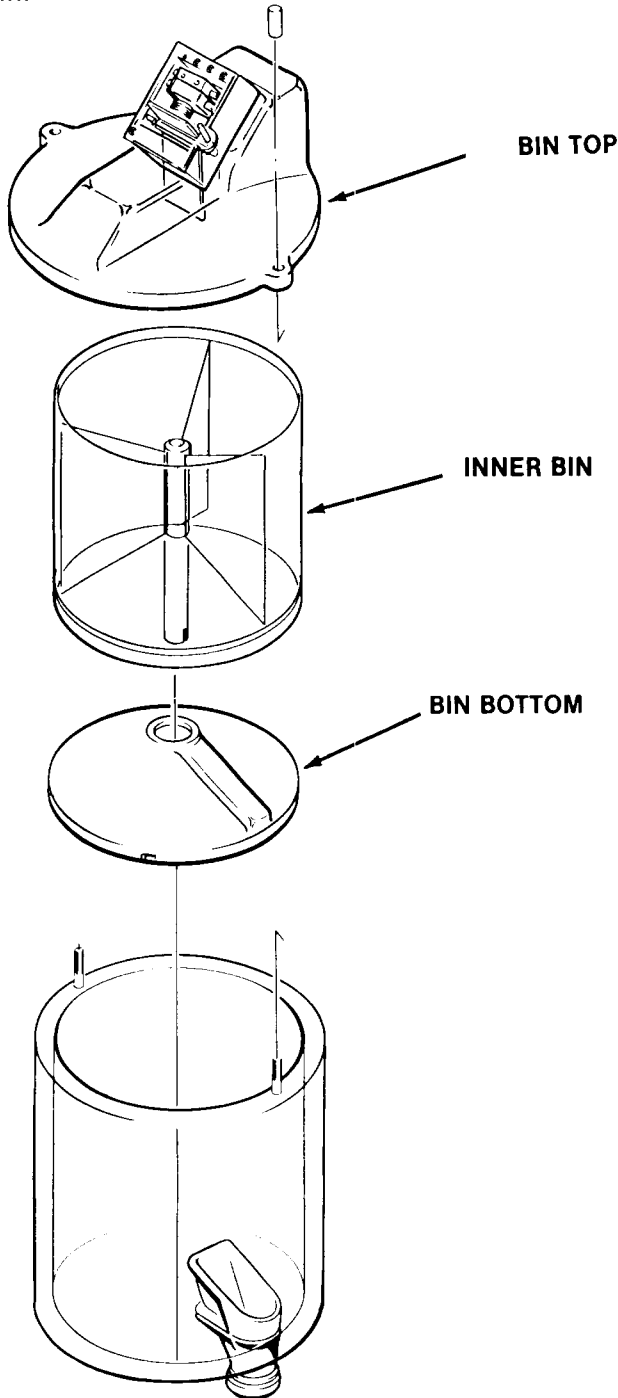

6. CLOSE the water supply shutoff valve or block the float in the water reservoir.
7. Use drain hose provided in the water feed tube and drain the reservoir.

//////////////////// WARNING //////////////////////

SCOTSMAN Ice Machine Cleaner contains Phosphoric and Hydroxyacetic acids. These compounds are corrosive and may cause burns. If swallowed, DO NOT induce vomiting. Give large amounts of water or milk. Call Physician immediately. In case of external contact flush with water. KEEP OUT OF THE REACH OF CHILDREN.

////////////////////////////////////

8. Prepare cleaning solution: Mix eight ounces of SCOTSMAN Ice Machine Cleaner with two quarts of hot water. (95⁰F.-115⁰F.)
9. Remove the cover to the water reservoir.
10. Slowly pour the cleaning solution into the water reservoir.
11. Reconnect electrical power.
12. Continue to slowly pour the solution into the water reservoir; maintain level just below the reservoir overflow.

REMOVE INNER BIN, AND BIN BOTTOM. CLEAN INNER BIN, BIN BOTTOM AND INSIDE OF BIN. POUR WATER INTO BIN TO RINSE DRAIN AND BE ASSURED DRAIN DRAINS IMMEDIATELY AND COMPLETELY.

13. Continue icemaking, using the cleaning solution, until all the solution is used up and the water reservoir is almost empty. DO NOT allow the icemaker to operate with empty reservoir.
14. Disconnect electrical power, OFF.
15. Wash and rinse the water reservoir.
16. OPEN the water supply shutoff valve or remove the block from the float in the water reservoir.
17. Connect electrical power, ON.
18. Continue icemaking for at least 15 minutes, to flush out any cleaning solution. Check ice for acid taste — continue icemaking until ice tastes sweet.

HQD550 MAINTENANCE AND CLEANING INSTRUCTIONS

//////////////////**WARNING**//////////////////

DO NOT USE ice produced from the cleaning solution. Be sure none remains in the cylindrical storage bin.

//////////////////

19. Remove all ice from the cylindrical storage bin.
20. Add hot (95⁰F. -115⁰F.) water to the cylindrical storage bin and removable bin bottom. Thoroughly wash and rinse all surfaces within the bin.
21. Clean and sanitize the cylindrical storage bin and removable bin bottom each week.

SANITIZING

Sanitizing is an important phase of the icemaking and dispensing operation. The following sanitizing procedure should be performed after every repair or replacement of parts in the icemaker/dispenser in or through which water flows or drains and ice is made, spouted, stored or dispensed. Additional requirements for performing the sanitizing procedure should be followed in accordance with the requirements of the local Health Authorities.

//////////////////**WARNING**//////////////////

This **WARNING** applies to the use of diluted household bleach as a sanitizing solution. Read this **WARNING** thoroughly before preparing sanitizing solution. **DANGER: KEEP OUT OF THE REACH OF CHILDREN.** If sanitizing solution should come in contact with eyes, flood with water. If taken internally, feed milk, contact a physician. If in contact with skin, flood with water. Do not use with other household cleaners, especially ammonia.

//////////////////

The following are directions for sanitizing with diluted household bleach, most local codes allow this type of sanitizer. Follow the directions of your local health department and use the sanitizer that is approved. Follow the directions and warnings of that sanitizer.

1. Mix one tablespoon of household bleach to two gallons of water in a container large enough to use with the parts that need to be sanitized.

2. Using rubber gloves, immerse the parts in the sanitizing solution and wash the parts, flushing the solution thoroughly in, over and through all parts and surfaces of the dispenser/icemaker parts being sanitized.

Note: If using a sanitizer that requires a contact time, be sure to allow the parts to soak for that time period.

3. Allow the parts to air dry.
4. Replace the sanitized parts in the reverse order of their removal.

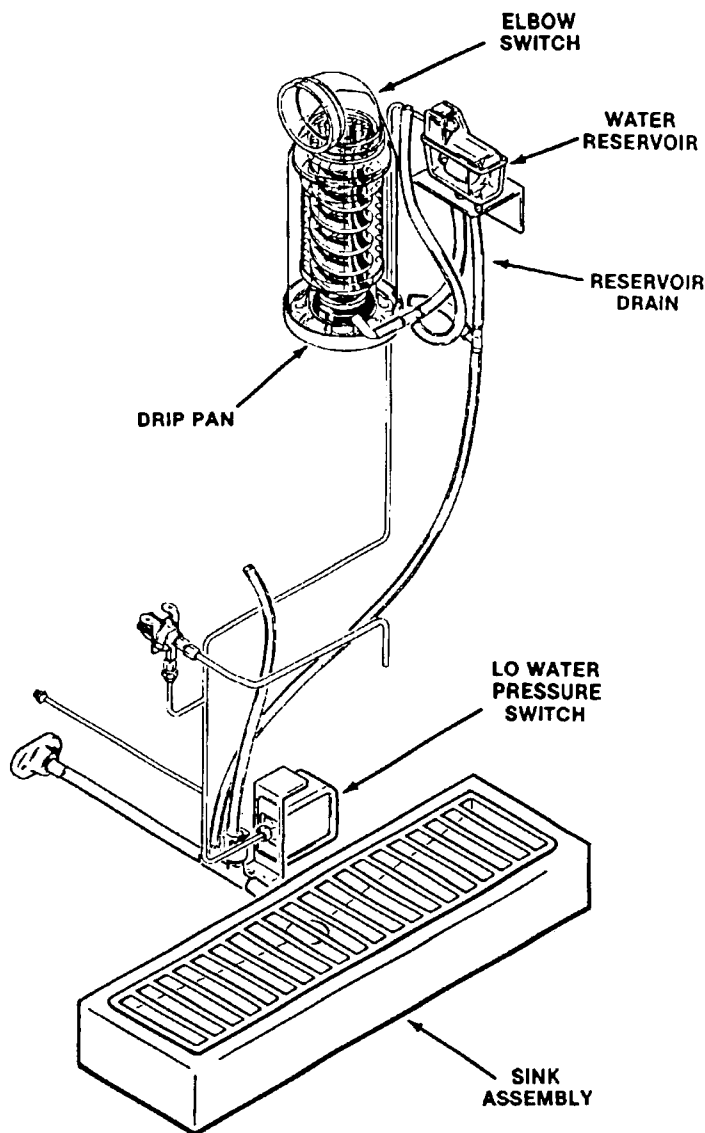

HQD550 SERVICE DIAGNOSIS

The Service Diagnosis Section is for use in aiding the serviceman in diagnosing a particular problem for pin-pointing the area in which the problem lies, thus an ever available reference for proper corrective action.

The following charts lists corrective actions for the causes of known symptoms of certain problems that can occur in the Dispensing System and the Icemaking - Refrigeration System.

DISPENSING SYSTEM

SYMPTOM	POSSIBLE CAUSE	CORRECTION
No water is dispensed. (Optional Kit)	Electrical power OFF.	Connect electrical power.
	Building water valve off.	Open valve.
	Defective water vend switch.	Replace switch.
	Defective water solenoid valve.	Replace defective valve.
No ice is dispensed.	Ice bin empty.	Check refrigeration system.
	Defective ice vend switch.	Replace switch.
	Broken or disconnected linkage.	Replace linkage.
	Bin drive motor defective.	Check, replace if defective.
	Jam in ice chute.	Remove obstruction.
Portion Control does not operate properly. Continues to operate when glass filler lever Assembly is held IN.	Timing module defective.	Replace defective timing module.
	Potentiometer switch defective.	Replace defective potentiometer.
	Loose connections or open wire leads to potentiometer.	Check terminal wiring, tighten connection, repair wiring.
Icemaker will not run, red light on.	Bin has over filled due to:	
	Failed bin switch.	Replace switch.
	Compressor contactor stuck on.	Replace contactor.
	Bin Switch differential too short - unit cuts in too soon.	Replace Switch.
	Holding relay has been de-energized due to:	
	Power interruption.	Check power supply.
	Voltage drop at a holding circuit switch.	Check all switch contacts in holding circuit.

HQD550 SERVICE DIAGNOSIS

ICEMAKING — REFRIGERATION SYSTEM

SYMPTOM	POSSIBLE CAUSE	CORRECTION
Water Leaks.	Water level in reservoir too high.	Adjust water level to 1/4-inch below reservoir overflow pipe.
	Defective water seal.	Replace water seal.
	Gravity feed line leaking.	Check hose clamps, tubing.
	O-ring in spout casting leaks.	Remove spout casting, install replacement o-ring.
Excessive noise or chattering.	Mineral or scale deposit on auger and inner freezing walls.	For severe deposits, remove and manually polish auger, sand inner chamber walls of freezer barrel. For lighter concentration, use SCOTSMAN Ice Machine Cleaner periodically.
	Dirty air-cooled condenser.	Clean condenser and fan blades.
	Improper refrigerant pressures.	Adjust head pressure control W/C only to recommend setting or balance refrigerant charge.
	Intermittent water supply.	Check and clean optional water strainer. Check gravity feed line for air lock and remove air lock.
	Water level in reservoir too low.	See CORRECTION for water leaks above.
	Gearmotor loose on frame.	Tighten gearmotor mounting bolts.
	Gearmotor end-play or worn bearing.	Repair or replace worn bearing
	Top bearing worn.	Check/replace breaker.
Compressor not snug on rubber mounts.	Repair or replace rubber mounts.	
Squeal noises in freezer.	Ice is too hard in freezer.	Raise water level in reservoir. Check suction pressure and adjust as necessary.

HQD550 SERVICE DIAGNOSIS

ICEMAKING — REFRIGERATION SYSTEM

SYMPTOM	POSSIBLE CAUSE	CORRECTION
Low ice production.	Loss of refrigerant. Under or over-charge of refrigerant.	Check system and recharge. See NAMEPLATE for correct charge.
	Drive motor weak.	Replace drivemotor.
	Dirty or plugged condenser.	Clean condenser.
	Low water level in reservoir.	Check float.
	Partial restriction in capillary tube or drier.	Moisture in system. Overcharge of oil in system. Remove charge by blowing back thru cap tube. Replace drier and recharge. See NAMEPLATE.
	Optional water strainer partially plugged.	Remove and clean strainer screen.
	Corroded to stained auger, due to water condition. Lime build up in freezer.	Remove and clean auger, or use SCOTSMAN Ice Machine Cleaner. See Maintenance & Cleaning.
Icemaker operates, but makes no ice.	Loss or undercharge of refrigerant.	Check for gas leaks, evacuate & recharge.
	Water not entering freezing Chamber. Plugged strainer or water inlet line.	Check and clean. Check, remove possible air lock in gravity feed line.
	Moisture in system.	Check, evacuate, replace drier, SEE NAMEPLATE & recharge system.
	Water seal leaks.	Replace water seal.
	Water turned OFF while icemaker was operating.	Freezer inlet water line froze shut. Shutdown and defrost icemaker.
Icemaker will not operate.	Manual safety switch tripped.	Reset switch.
	Blown fuse.	Replace fuse and check for cause of blown fuse.
	Low pressure control activated.	Check for cause.
	Head pressure control activated.	Check cause of decreased or loss of water to water-cooled condenser.
	Bin ice level switch stuck, pushed IN.	Repair or replace switch.
	Electrical power disconnected.	Connect electrical power ON.

HQD550 ADJUSTMENT PROCEDURES

ADJUSTMENT OF THE LEG LEVELERS

When the icemaker is installed with legs, the legs must be adjusted to level the cabinet. The cabinet must be leveled in the front-to-back and side-to-side directions. This adjustment should be performed during initial installation of the cabinet and anytime the cabinet is moved from the original location to another site.

1. Using a 1-1/8" open-end wrench, and a carpenter's bubble level, rotate the threaded leveler in each leg to RAISE or LOWER the cabinet until the cabinet is level in the front-to-back direction.
2. Repeat step A, for leveling in the side-to-side direction.
3. Recheck both the front-to-back and the side-to-side leveling and repeat adjustments, as necessary.

ADJUSTMENT OF THE WATER REGULATOR ASSEMBLY

The correct head pressure on water-cooled models is 135 PSIG. Adjustments can be performed on the water regulator assembly to increase or decrease the head pressure.

To adjust the water regulator assembly:

1. To INCREASE the head pressures: Rotate the adjusting screw, on the water regulator assembly COUNTER-CLOCKWISE.
2. To DECREASE the head pressure: Rotate the adjusting screw, on the water regulator assembly CLOCKWISE.

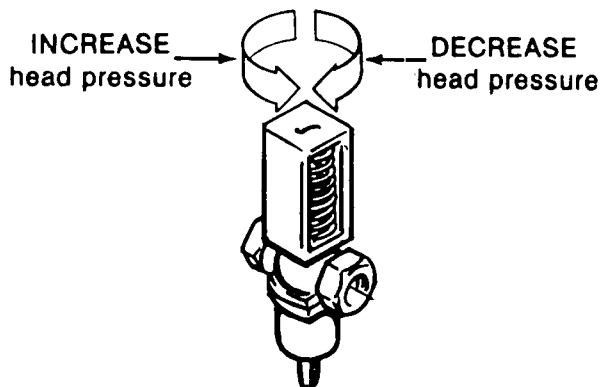

ADJUSTMENT OF THE WATER RESERVOIR FLOAT

The correct water level in the water reservoir should be at the level of the raised molded line, on the side of the body of the water reservoir. When the water line level is above or below the raised molded line, adjustment can be performed to raise or lower the water level by bending the metal arm of the float inside the water reservoir.

To adjust the water reservoir float:

1. To RAISE the water level:
Hold one end of the metal arm of the float and slightly bend the float up.
2. To LOWER the water level:
Hold one end of the metal arm of the float and slightly bend the float DOWN.
3. To perform MAJOR adjustment:
When repair or replacement has been performed and the water level line between the water reservoir and the freezer assembly has been substantially altered:
 - a. Loosen the three screws and lockwashers which attach the reservoir bracket and water reservoir to the freezer mount.
 - b. Move the reservoir bracket UP or DOWN to properly position the water line level within the freezer. The proper water level within the freezer is 1/2" - 3/4" below the top of the auger.
 - c. When proper water level within the freezer is adjusted, re-tighten screws attaching the water reservoir bracket to the freezer mount.

HQD550 REMOVAL AND REPLACEMENT PROCEDURES

HQD550's have been manufactured in "A", "B" and "C" Models (as in model HQD550AE-1A vs. HQD550AE-1C.) The following instructions are designated for either "A", "B" or "C" models. Be certain to check your model number and refer to the appropriate steps.

Read the instructions thoroughly before performing any Adjustment or Removal and Replacement Procedures.

////////////////////// **WARNING** ////////////////////////

Be sure the electrical power supply and the water supply are OFF, BEFORE starting any of the following REMOVAL AND REPLACEMENT procedures as a precaution to prevent possible personal injury or damage to equipment.



REMOVAL AND REPLACEMENT OF THE AUGER, WATER SEAL, O-RING, ICE BREAKER ASSEMBLY AND FREEZER ASSEMBLY (A, B and C MODELS)

To remove the auger, water seal, o-ring and ice breaker assembly:

1. Shut off water supply to the icemaker/dispenser at the building source.
2. Disconnect or shut-off electrical power to the icemaker at the building source.
3. Remove screws and push UP to unsnap catches and remove top panel.
4. Remove screws and remove the front panel.
5. Remove retaining nuts and remove bin top.
6. Separate insulation halves and remove from the elbow safety switch.
7. Remove three socket head screws and spout retaining brackets from the end of the spout assembly at the top of the freezer assembly.

NOTE 1: To service icebreaker/top bearing only, do steps 1-9 and 11 only. Refer to page 36 for ice breaker service. Reverse disassembly procedures to re-assemble.

NOTE 2: The control box may be removed from its mounting position for better access to the gearmotor and freezer assembly.

8. Lift the elbow safety switch and spout UP, off of the freezer assembly.
 9. Retain the o-ring for replacement during reassembly. Inspect for cuts, tears or excessive wear, causes for replacement.
 10. Remove hose clamp and disconnect the water feeder tube from the reservoir, at the freezer to drain the reservoir and freezer of water.
 11. Remove four capscrews, lockwashers and the ice breaker assembly from the top of the freezer assembly.
 12. Retain the o-ring for replacement during reassembly. Inspect for cuts, tears or excessive wear, causes for replacement.
 13. Remove the auger. If necessary a bolt can be threaded into the top end of the auger from the freezer and a hand tool used to pull on the bolt to remove the auger.
- To remove Water Seal only, omit steps 15, 16, and 17.**

TO REMOVE FREEZER ASSEMBLY:

14. Pull back permagum around freezer base mounting bolts and remove four screws and flatwashers. Separate the freezer assembly, gasket and adapters, from the drivemotor assembly.
15. Bleed off or blow the refrigerant charge through the Schrader valve.
16. Unsolder and disconnect the refrigerant suction line at the compressor, and the associated capillary line at the drier.
17. Remove the freezer assembly from the chassis.

A and B MODELS

18. Using a suitable length and size wooden dowel or stick inserted through the top of the open freezer assembly, tap the stationary piece water seal out the bottom of the freezer assembly.

C MODEL

18. Remove snap ring from inside bottom of evaporator assembly. Using a suitable length and size of wooden dowel or punch inserted through the top of the open freezer assembly, tap the stationary portion of the water seal out the bottom of the freezer assembly.

HQD550 REMOVAL AND REPLACEMENT PROCEDURES

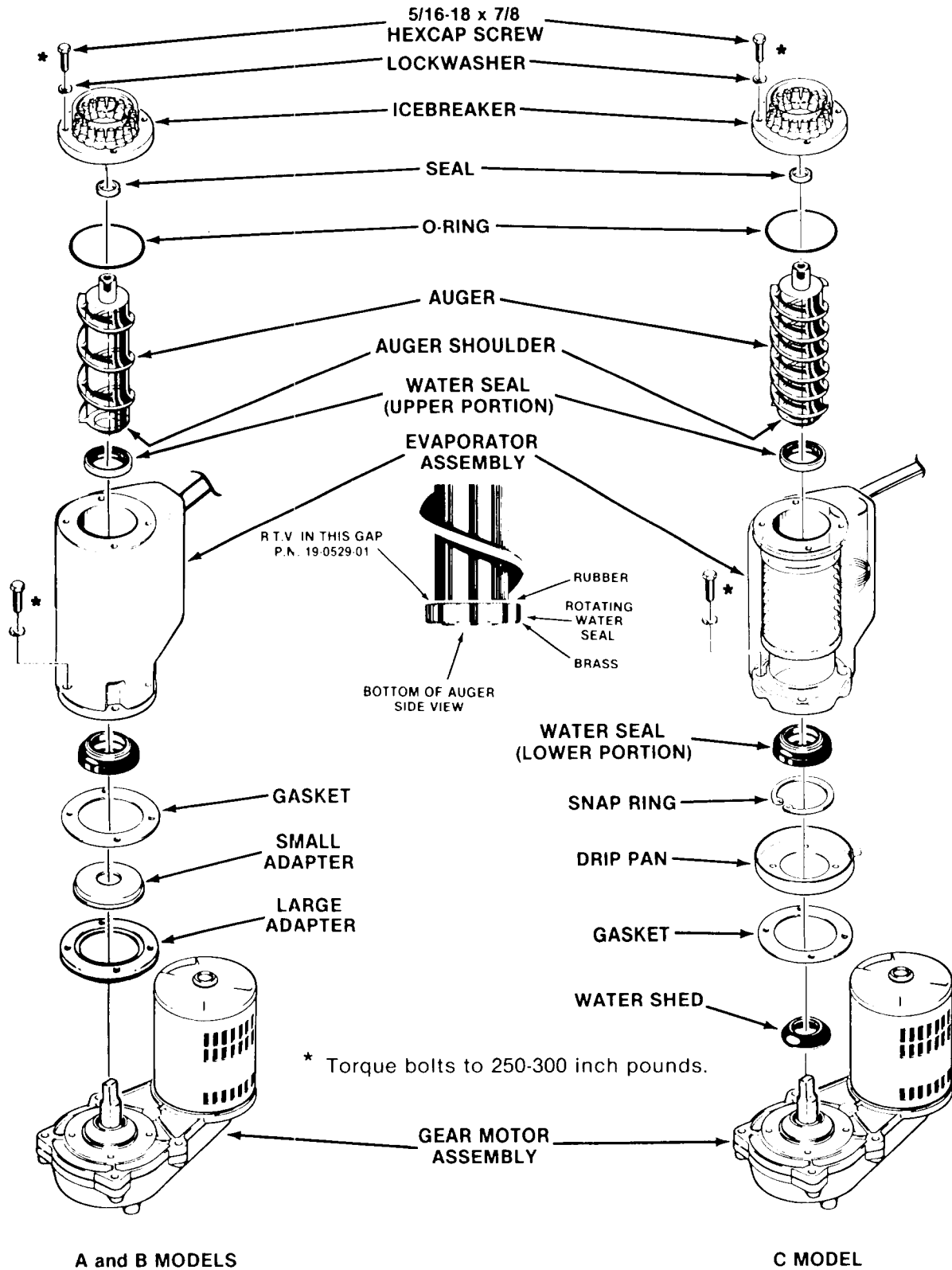

HQD550 REMOVAL AND REPLACEMENT PROCEDURES

19. Replace the water seal any time it has been removed.

////////// **CAUTION** //////////

The lower two-part water seal is a precise seal and fitting. Any damage or wear will cause a failure. It is recommended that the lower two-part water seal be replaced any time there is a question of condition.

//////////

A and B MODELS

20. Replace the parts starting with the stationary part of the water seal. Carefully inspect it prior to assembly. Insert this half of the water seal into the bottom of the freezer. Then insert the brass freezer adapter into the bottom of the freezer tube and push it in as far as it will go.

C MODEL - OR REPLACEMENT FREEZER

20. Replace the new stationary portion of the two-part water seal in the bottom of the freezer assembly and press in far enough to install the snap ring. **IMPORTANT:** pull water seal back down against snap ring all the way around the freezer.

A and B MODELS

21. Mount the freezer and gasket to the gear motor case. Be certain that the gearmotor is in good working condition and that the large plastic adapter is in place on the gearbox.

C MODEL - OR REPLACEMENT FREEZER

21. Mount the freezer, drip pan and gasket to the gearmotor case. Check to be sure the gearmotor is in good condition and the water shed is in place around the output shaft.

22. Apply Scotsman part number 19-0529-01 RTV silicone rubber to the auger shoulder before pushing on the water seal. Place just enough silicone on to the auger, so that when the water seal is placed on the auger, the gap between the auger shoulder and water seal is completely filled with silicone.

The silicone must be allowed to "set-up" or dry on the surface before any water can be added to the freezer.

////////// **CAUTION** //////////

If any silicone gets onto the mating surfaces of the water seal, the seal is ruined, and cannot be used.

//////////

23. Install auger.

24. Replace breaker.

25. Reassemble ice transport tube, insulation, and bin top assembly in reverse order of disassembly.

////////// **CAUTION** //////////

DO NOT force the auger and breaker together without having the vent hole open because pushing the breaker on with no air relief will cause the internal air pressure to force the grease seal away from the breaker.

//////////

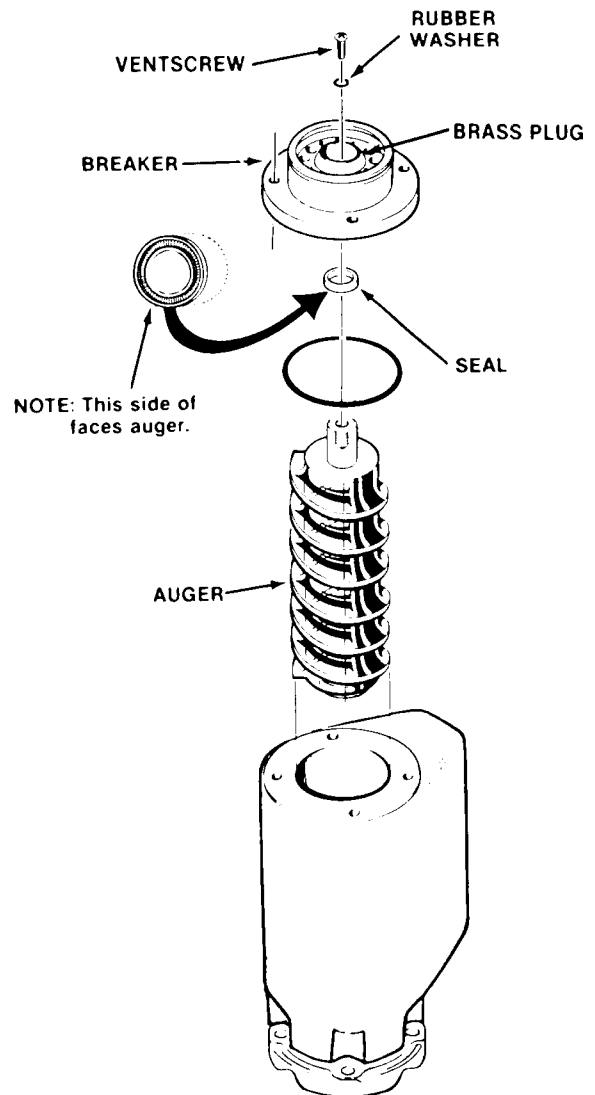

HQD550 REMOVAL AND REPLACEMENT PROCEDURES

//////////////////// **WARNING** //////////////////////

Disconnect electrical power supply before removal procedures.



REMOVAL AND REPLACEMENT OF THE COMPRESSOR ASSEMBLY

To remove the compressor assembly:

1. Remove two screws, push UP to unsnap catches and remove the top panel.
2. Remove two screws, pull OUT to unsnap catches and remove front panel.
3. Remove screws and back splash panel.
4. Remove screws and sink assembly; then, remove hose clamp and disconnect drain hose. Remove the sink assembly and grill from the cabinet.
5. Bleed off or blow the refrigerant charge through the schrader valve.
6. Remove the cover from the terminal box on the compressor; then, disconnect electrical leads from the compressor.
7. Unsolder and disconnect the refrigerant suction line and the discharge line from the compressor.
8. Unsolder the process header from the compressor and retain for installation on the replacement compressor.
9. Remove three nuts, washers, mounting sleeves and grommets and the compressor from the chassis base.

To replace the compressor assembly, reverse the removal procedure.

REMOVAL AND REPLACEMENT OF THE CONDENSER ASSEMBLY — AIR-COOLED

To remove the condenser assembly:

1. Remove screws and left side panel; then, remove screws and splash panel to gain access to the condenser assembly. Bleed off refrigerant charge.
2. Unsolder and disconnect refrigeration lines from the condenser.
3. Unsolder and remove the drier from the refrigerant line connected to the condenser.
4. Remove screws, lockwashers and air-cooled condenser from the chassis base.

To replace the air cooled condenser, reverse the removal procedure.

//////////////////// **NOTE** //////////////////////

Always install a replacement drier, anytime the sealed refrigeration system is opened. Do not replace the drier until all other repair or replacement has been completed.

HQD550 REMOVAL AND REPLACEMENT BREAKER/BEARING/WATER SEAL ASSEMBLY

INSPECTION:

If, when the breaker is removed from the evaporator, the yellow water seal stays on the auger, replace the breaker. If the auger shaft is rough or scored, it and the ice breaker must be replaced. If the auger shaft can be cleaned up, do NOT use an abrasive material; a nylon scouring pad used for cleaning dishes will do a very good job.

The bearing in the breaker is not replaceable. The breaker must be replaced when the bearing is worn past 1.009"ID.

The method of retaining the water seal in the nugget ice breaker was changed in early 1988.

The newest breakers have, at the water seal mounting location, a "lip" protruding into the inner diameter of the breaker.

This "lip" is at the bottom of the seal, retaining the seal in the breaker. The seal is retained so positively, that it cannot be removed without ruining it.

TO REPLACE THE SEAL IN THE BREAKER:

1. Pull old seal out with a pliers.
2. Place new seal on auger shaft, open side down.
3. Push breaker onto auger and seal as far as it will go.
4. Remove breaker and seal from auger, use your thumbs to push the seal all the way into the breaker.

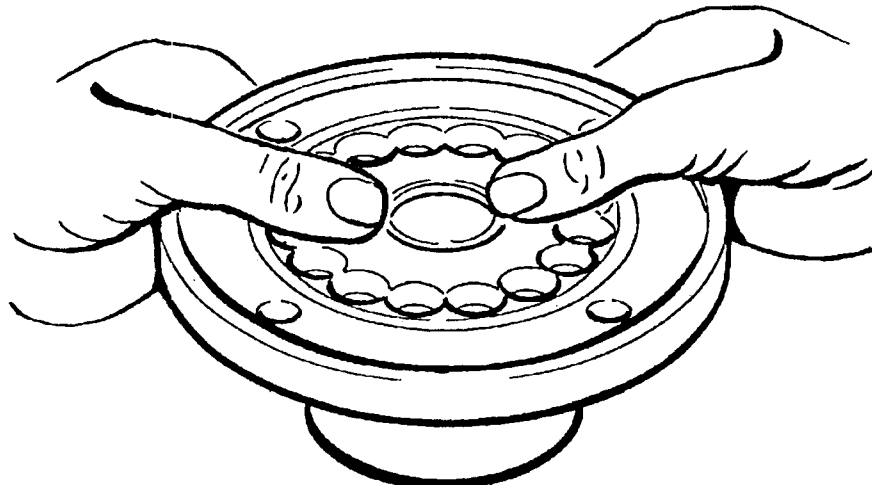
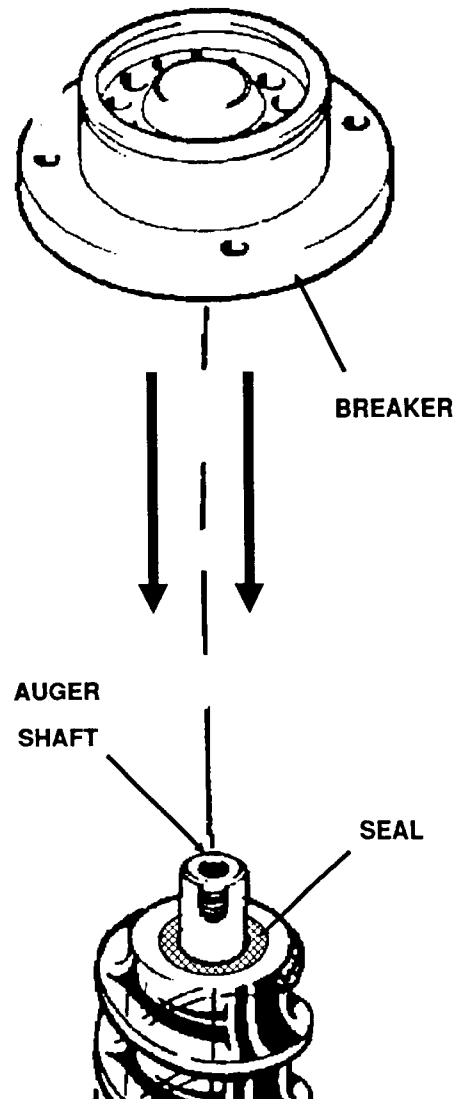

HQD550 REMOVAL AND REPLACEMENT PROCEDURES

//////////////////// WARNING //////////////////////

Disconnect electrical power supply before removal procedures.

////////////////////////////////////

REMOVAL AND REPLACEMENT OF THE DRIER

NOTE: Always install a replacement drier, anytime the sealed refrigeration system is opened. Do not replace the drier until all other repair or replacement has been completed.

To replace the drier:

1. Remove four screws and slide the backsplash assembly out from behind the dispensing assembly.
2. Remove screws attaching sink assembly to cabinet, then, remove hose clamps and disconnect drain hose, behind the sink assembly. Remove the sink assembly and grill from the cabinet.
3. Bleed off or blow the refrigerant charge through the Schrader valve.
4. Remove attaching hardware and drier brace or strap from the drier.
5. Unsolder refrigeration lines at both ends of the drier.

To replace the drier:

//////////////////// CAUTION //////////////////////

1. If the factory seal is broken on the replacement drier, exposing it to the atmosphere more than a few minutes, the drier will absorb moisture from the atmosphere and lose substantial ability for moisture removal.
2. Be sure the replacement drier is installed with the arrow positioned in the direction of the refrigerant flow.

////////////////////////////////////

1. Remove the factory seals from the replacement drier and install the drier in the refrigerant lines with the arrow positioned in the direction of the refrigerant flow.
2. Solder the drier into the lines, two places.
3. Secure drier with the drier brace or strap.
4. Purge the system and check for leaks.
5. Thoroughly evacuate the system to remove moisture and non-condensables.
6. Charge the system with refrigerant, by weight. SEE NAMEPLATE.
7. Replace and attach the sink assembly and backsplash assembly.

REMOVAL AND REPLACEMENT OF THE INNER BIN DRIVE MOTOR ASSEMBLY

To remove the drive motor:

1. Remove screws and splash panel to prepare for removal of the drive motor.
2. Remove four mounting plate screws and remove the drive motor from the cabinet.

To replace the drive motor assembly, reverse the removal procedure.

REMOVAL AND REPLACEMENT OF THE FAN MOTOR ASSEMBLY

To remove the fan motor assembly:

1. Remove four screws and slide the backsplash assembly from behind the dispensing assembly.
2. Disconnect electrical lead from the fan motor.
3. Remove two screws and lockwashers securing the fan motor bracket to the chassis base and remove the fan motor assembly and bracket from the cabinet.
4. Remove the nut from the end of the fan motor shaft and remove the fan blade.
5. Remove four screws securing the fan motor to the motor bracket and separate the motor from the bracket.

To replace the fan motor assembly, reverse the removal procedure.

HQD550 REMOVAL AND REPLACEMENT PROCEDURES

REMOVAL AND REPLACEMENT OF THE ELBOW AND SWITCH ASSEMBLY

To remove the elbow and switch assembly:

1. Disconnect the electrical supply to the icemaker at the circuit breaker or fuse box.

//////////////////// **WARNING** //////////////////////

Be sure the electrical power supply to the icemaker is OFF before proceeding with removal procedures.

////////////////////////////////////

2. Remove screws and remove top panel.
3. Remove insulation halves from the elbow switch assembly.
4. Loosen the screw on the screw clamp and U-channel securing the ice transport tube to the elbow and safety switch.
5. Separate the ice transport tube from the elbow.

6. Remove bolt and washer and remove switch support from the ice breaker.
7. Remove three Allen head screws and spout retaining brackets from the freezer assembly and elbow and switch assembly.
8. Lift the elbow and switch assembly UP to clear the top of the freezer assembly.
9. Remove screws and the switch from the switch actuator housing.
10. Rotate the retainer ring 90-degrees to unlock the retainer ring and the switch actuator housing from the elbow assembly and separate the parts from the elbow.
11. Inspect the rubber diaphragm for cuts, tearing or excessive wear.

To replace the elbow and switch assembly, reverse the removal procedure.

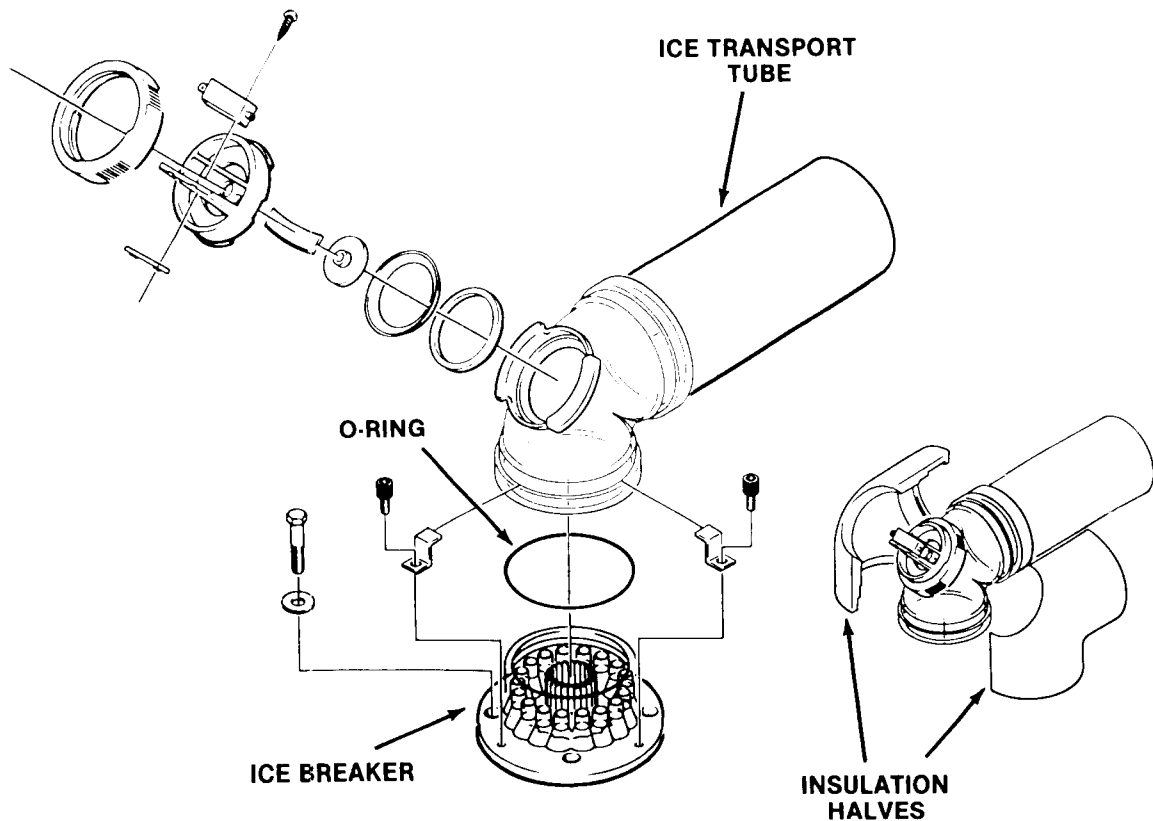

HQD650 REMOVAL AND REPLACEMENT PROCEDURES

//////////////////// WARNING //////////////////////

Disconnect electrical power supply before removal procedures.



REMOVAL AND REPLACEMENT OF THE WATER PRESSURE SWITCH ASSEMBLY

To remove the low water pressure switch assembly:

1. Remove screws and the splash panel.
2. Disconnect electrical leads in the control box from the low pressure switch.
3. Unscrew the flare nut fitting and disconnect the low pressure control and washer from the bracket.

To replace the low water pressure control assembly, reverse the removal procedure.

REMOVAL AND REPLACEMENT OF THE WATER REGULATOR ASSEMBLY — WATER-COOLED MODELS

To remove the water regulator assembly:

NOTE: Always install a replacement drier, anytime the sealed refrigeration system is opened. Do not replace the drier until all other repair or replacement has been completed.

1. Remove screws and splash panel.
2. Bleed off or blow the refrigerant charge through the schrader valve.
3. Unsolder the capillary line from the water regulator, at the process header.
4. Disconnect the water inlet line at the pipe fitting on the pipe nipple assembly bracket.
5. Unscrew the flare nut fitting, on the water regulator, and disconnect the water line from the water regulator to the water-cooled condenser.
6. Remove screws, lockwashers and the water regulator assembly from the chassis base.

To replace the water regulator assembly, reverse the removal procedure.

REMOVAL AND REPLACEMENT OF THE WATER RESERVOIR ASSEMBLY

To remove the water reservoir assembly:

1. Push UP to unsnap catches and remove the top panel.
2. Pull OUT to unsnap catches and remove the front panel.

NOTE: Be prepared with container or rags, to catch water left in lines, when lines are disconnected in next steps, to prevent draining water on parts, components, electrical lines, etc.

3. Disconnect the water inlet tube from the water reservoir assembly.
4. Remove two corbin clamps and two tubes from the bottom of the water reservoir assembly.
5. Unscrew and remove the plastic wingnut from the bottom of the water reservoir assembly.
6. Lift and remove the water reservoir assembly from the mounting bracket.

To replace the water reservoir assembly, reverse the removal procedure.

NOTE: Check that the installed replacement water reservoir assembly float moves freely. The correct water level in the water reservoir is 3/8-inch below the raised molded line, on the side of the body of the water reservoir.

HQD550 REMOVAL AND REPLACEMENT PROCEDURES

REMOVAL AND REPLACEMENT OF THE GEAR MOTOR

////////// WARNING //////////

Be sure the electrical power supply to the icemaker is OFF before proceeding with removal procedures.

To remove the auger drivemotor:

1. Disconnect electrical power leads from the motor.
2. Unscrew four capscrews securing motor to gearcase.
3. Lift off motor winding from the gear reducer.
4. Use a pry bar to remove rotor and rotor bearing from the gearcase.
5. Examine grease seal in gearcase. Replace if worn. Add grease to seal and bearing housing before re-assembly.

To replace, reverse the removal procedures.

NOTE

Motors must be exchanged complete. DO NOT mix rotors, housings or windings.

REMOVAL AND REPLACEMENT OF THE GEAR MOTOR ASSEMBLY

////////// WARNING //////////

Be sure the electrical power supply to the icemaker is OFF before proceeding with removal procedures.

////////// CAUTION //////////

SHUT OFF water supply to icemaker.

To remove the gear motor assembly:

1. Refer to Removal and Replacement of the Elbow & Switch Assembly and perform steps to gain access to the freezer assembly.
2. Thread suitable length bolts, having No. 5/16-18 UNC-2B threads, into thread hold in the top of the auger. Grasp bolt head with hand tool and pull auger out.
3. Unbolt freezer from gear motor assembly, lift up and off gear motor.
4. Remove the drivemotor cover and disconnect the three electrical wire leads.
5. Remove bolts holding gear motor plate to the machine base.

6. Lift the gear motor from the machine base.
To replace the gear motor assembly, reverse the removal procedure.

*Torque bolts to 250-300 inch pounds.

REPAIR OF THE GEAR MOTOR ASSEMBLY

1. Remove (6) cap screws to prepare to open gearcase.
2. Pry the two cases apart. Inspect the internal parts, look for:
 - Condition and quality of lubricant. (The proper oil level is flush with the top of the output (biggest) gear.)
 - Gear and gear shaft condition
 - Woodruff key between output gear and shaft
 - Grease seals, back to back
 - Vent hole open
 - Thrust bearing intact.

Be sure to count and retain the spacer washers as they come out of the gearbox.

Replace the parts as required, using the part numbers found in the parts list section of this manual. Replace the gears into a CLEAN bottom gearcase, replacing the spacer washers in the same quantity as they were upon disassembly. If no count was kept, refer to the parts illustration.

NOTE: Some bearing grease should be placed in all bearings before assembly to insure proper lubrication upon start-up.

To reassemble:

1. Set top gearcase on gears and spacers and oil. Output gear when installed must be assembled with the flush, machined side DOWN and the protruding bossed center UP. Be sure O-ring is in place.
2. Replace gearcase cover. Drive in alignment pins before tightening cap screws and torque at 250-300 inch pounds.
3. Bench test the gearmotor assembly.

Test for noise, amp draw (must not be in excess of icemaker nameplate for gearmotor) and oil leaks.

Return gearbox to the unit. Be certain all mounting surfaces are clean and reassemble gearbox to chassis and freezer assembly.

If the freezer water seal begins to leak, removal of the auger is required in order to replace the top bearing and water seal. AT THE SAME TIME, it would be recommended to remove the gearmotor assembly, open it up and inspect it.

HQD550 REMOVAL AND REPLACEMENT PROCEDURES

