

TABLE OF CONTENTS

Table of Contents	1
Photo	2
Specifications & Dimensions	3
Preparation for Installation	4
Installation	5
Installation (Bin Components)	6
Installation Schematic	7
Final Check List	8
Start Up	8
Refrigeration Schematic	9
Wiring Diagram (Air Cooled)	10
Wiring Diagram (Water Cooled)	11
Service Analysis	12-14
Cleaning Dispenser Mechanism	15
Maintenance Instructions (Ice Making Section)	15
Ice Shutter Control Schematic	16
SERVICE INSTRUCTIONS:	
Freezer Gearmotor	17
Freezer Assembly	17
Freezer Worm Shaft	17
Freezer Ass'y, Top Bearing	17
Freezer Ass'y, Bottom Bearing and Water Seal	18
Bin Full Switch	18
Water Reservoir	18
Head Pressure Control (Water Cooled)	19
Low Pressure Control	19
Water Regulating Valve (Water Cooled)	19
Bin and Auger Drive Unit Ass'y	19
PARTS BREAKDOWN:	
Front View (Air Cooled)	20
Side View (Air and Water Cooled)	21
Front View (Water Cooled)	22
Freezer Ass'y	23
Gear Motor Ass'y	24
Drive Unit Ass'y	25
Spout Ass'y	26
Shutter Actuator Ass'y	27
Shutter Actuator Rod Ass'y	28
Bin Full Switch Ass'y	28
Ice Discharge Spout Ass'y	29
Reservoir Ass'y	30
Control Box (Air Cooled)	31
Control Box (Water Cooled)	32
Cabinet Parts	33
Optional Switch Mounting and Accessories	34

**THIS PAGE
INTENTIONALLY
LEFT BLANK**



ICE MAKER DISPENSER

MODEL FD7 SERIES

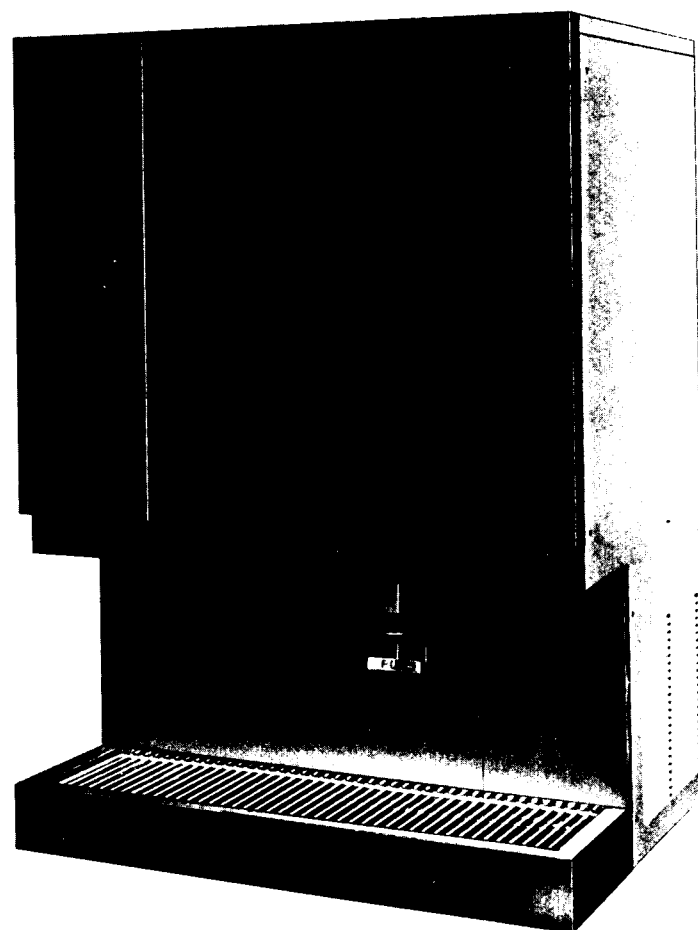

ice making capacity

Daily Ice Capacity is directly related to condenser air inlet temperature, water temperature, and age of machine.

NOTE: To keep your SCOTSMAN ICEMAKER DISPENSER performing at it's maximum capacity, it is necessary to perform periodic maintenance as outlined on page 15 of this manual.



SCOTSMAN

FD7
Page 3

FD7 SERIES

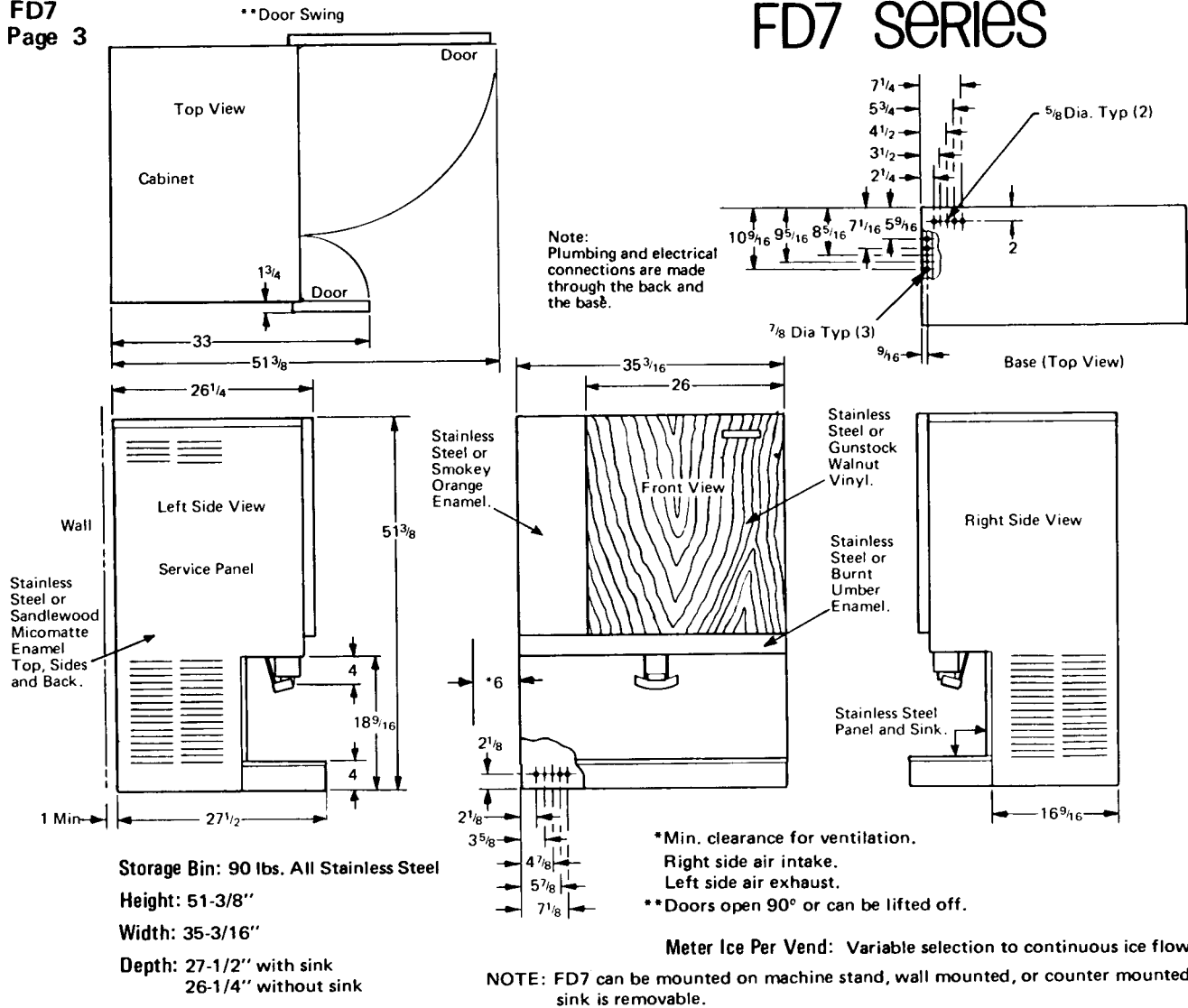

SPECIFICATIONS:

Model	Condensing Unit	Compressor Horsepower	Finish (P-painted) (SS-Stainless Steel)	Shipping Weight (lbs.)	Basic Electricals	Minimum Wire Sizes (w-wire) (g-gauge)	Total Amperages
FD7AE	Air	1/2	P*	600	Air Cooled 115/60/1	2w 12g	16.7
FD7AS	Air	1/2	SS	600			
FD7WE	Water	1/2	P*	600	Water Cooled 115/60/1	2w 12g	16.7
FD7WS	Water	1/2	SS	600			

*(Painted model has woodgrain front storage door panel)

Specifications subject to change without notice.

PREPARATION FOR INSTALLATION

1. The entire unit comes in one crate. Upon delivery a visual inspection of the crate and ice machine should be made and any severe damage noted should be reported to the delivering carrier and a concealed damage claim filed subject to internal inspection with carrier representative present.
2. Remove lower front panel and left side panel. Open and remove front service access doors.
3. Install unit on machine stand or counter top with a flat, level rigid top. Mount at convenient height for filling glasses. To mount on the wall order special wall mounting kit.
4. Thru left side of machine, locate metal reservoir. Remove water reservoir cover and take out paper packing around float ball.
5. Route the drains from the cabinet. They may be routed through the rear panel or through the base. It is possible to route all lines through holes which have been provided in the base.
6. The lower drain from the sink area must never be installed higher than the base of the cabinet. Consideration should be made in regard to this drain in order to get proper flow from the sink drain.
7. Water should be supplied from a 3/8" copper or equivalent pipe. Too small a water supply line will only result in an increase in time for filling glasses with water.
8. Open electrical junction box cover on back panel of machine and check unit nameplate voltage against building source voltage and make sure they correspond. Caution - Improper voltage supplied to units will void your parts replacement program.
9. Select unit location prior to hookup of water drain and electrical in accordance with local and national codes. Minimum room temperature is 50 degrees Fahrenheit, maximum room temperature 100 degrees Fahrenheit. On air cooled models, select well ventilated location.
10. Locate and tear out registration card from front of Users Manual and fill out card completely including model and serial numbers as taken from aluminum plate found behind front service panel. Forward to Scotsman Factory using self-mailing card, for your personal registration certificate.
11. Call your local authorized Scotsman Service Agency for hook-up, start-up and check out. He's listed under "Ice Making Machinery & Equipment" in your telephone book, yellow pages.

WARNING: THIS MACHINE MUST NOT BE ALLOWED TO OPERATE WHEN THE WATER SUPPLY IS SHUT OFF, OR AT BELOW RECOMMENDED WATER PRESSURE. TURN MASTER SWITCH TO "OFF" POSITION WHEN WATER SUPPLY IS OFF, OR WHEN WATER PRESSURE IS BELOW RECOMMENDED OPERATING PRESSURE.

INSTALLATION

ELECTRICAL CONNECTIONS:

FD7AE-1

115 Volts, 60 Cycle, 1 Phase
30 Amp. Circuit

12 Gauge wire should be used for electrical hook-up. Model FD7 requires a solid earth ground wire.

Be certain that the dispenser is on its own circuit and individually fused. The maximum allowable voltage variation should not exceed 10 per cent of the nameplate rating even under starting conditions. Low voltage can cause erratic operation and may be responsible for serious damage to the overload switch and motor windings.

All external wiring should conform to the National, State and local Electrical Code requirements. Usually an electrical permit and the services of a licensed electrician will be required.

ELECTRICAL INSTALLATION FD-7

Compressor	1/2 HP	Copelaweld: RSN2-0050-1AA	
		2 pole, 3500 RPM	
	Voltage	115	
	Amp. rating F.L.A.	11.2	
	Cycle	60	
	Phase	Single	
Gear Drive Motor (Freezer)	1/4 HP	Queen Products	
	Voltage	115	
	Amp. rating F.L.A.	4.7	
	Cycle	60	
	Phase	Single	
		Thermally Protected	
Gear Drive Motors (Vend)		<u>Bin Drive</u>	<u>Auger Drive</u>
	Voltage	115	115
	AMP Rating	3.3	1.2
	Cycle	60	60
	Phase	Single	Single
Fan Motor (Air Cooled)	Voltage	115	
	AMP Rating	.9	
	Cycle	60	
	Phase	Single	

WATER SUPPLY:

A single cold water supply line is required. Recommend tubing size 3/8" O.D. or larger, cabinet connection is to a 3/8" S.A.E. flare tee. A water strainer with clean out feature should be installed in supply line along with a hand shut off valve.

Minimum water pressure is 20 pounds gauge, maximum pressure over 50 pound gauge may cause chattering of float ball in reservoir tank. For pressures in excess of 50 pounds, use a water pressure regulator in line. Holes are provided in back and bottom of unit for supply line entrance.

DRAIN:

Water and Condensate Drains: Run separate drain lines for each drain provided from machine. 5/8" I.D. tubing drain from ice storage compartment. 3/8" I.D. tubing drain from flaker freezer assembly. 7/8" I.D. tubing drain sink, if used, 3/8" O.D. copper drain from water cooled condenser or water cooled units only. Drain lines should be run to an open, trapped or vented drain in accordance with your State and local code.

INSTALLATION BIN COMPONENTS

FD7
Page 6

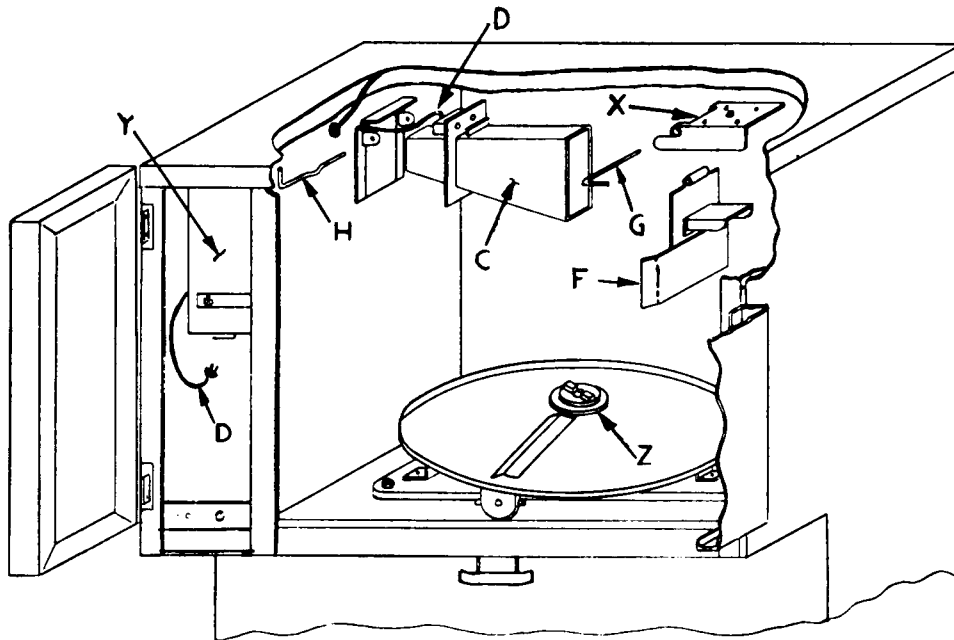

1. Remove parts container, divider, and styrofoam filler from upper compartment. Remove bin by unscrewing locking cap "B" from center of bin.
2. Completely clean spout, differential plate, upper compartment and bin using Scotsman cleaning solution. Rinse thoroughly.
3. Install parts in this order:
 - A. Place Bin "A" on drive lug "Z" of the gear unit. Turn the bin until it seats on the lugs of "Z".
 - B. Screw locking cap "B" down snug in the center of the bin.
 - C. Place differential plate "F" in place on plate "X".
 - D. Insert pin "G" through holes to hold the plate in place.
 - E. Turn handle of pin down behind tab of plate "X".
 - F. The differential plate "F" is installed with the tab to the right so it actuates the switch in the cover when it is pushed backward or to the right.
 - G. Pull cord "D" of the flaker spout "C" through the flaker opening. Bring it down the side of the compartment and plug it into a receptacle in box "Y."
 - H. Push flaker spout "C" through compartment opening and place over cast spout of freezer.
 - I. Push spout tight against compartment opening and insert pin "H".
 - J. When "H" is in place pull handle down to lock it in place.
 - K. **WARNING:** Pins "H" and "G" must be locked in place. Any part that falls in the bin will cause serious damage to the unit.

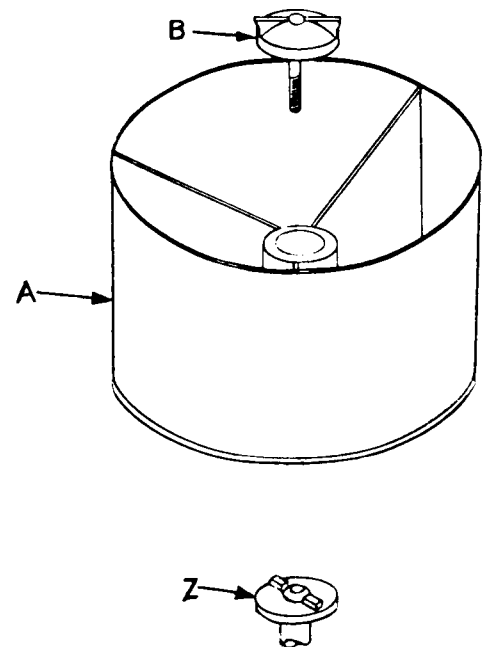

INSTALLATION SCHEMATIC

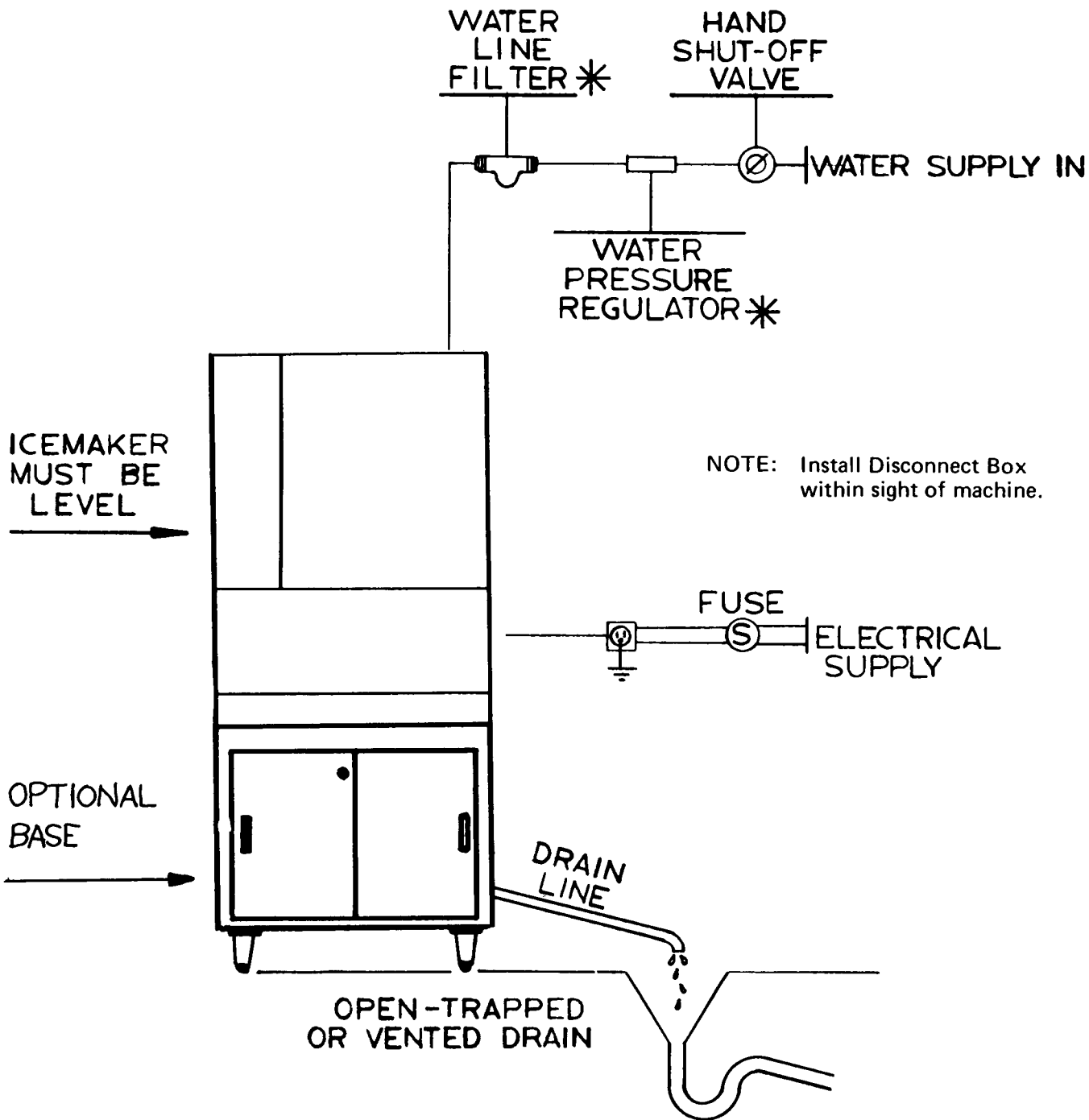

* REGULATOR AND FILTER ARE ACCESSORY ITEMS
TO BE INSTALLED AS CONDITIONS WARRANT

FINAL CHECK LIST

1. Is the unit level? (IMPORTANT)
2. Have all electrical and piping connections been made?
3. Has the voltage been tested and checked against the nameplate rating?
4. Is the water supply valve open and the electric power on?
5. Is the water reservoir filled and shut off? All packing removed?
6. Have unit and bin been wiped clean?
7. Has owner been given this Operating Instruction Booklet, and has he been instructed on how to operate the machine?
8. Have the installation and registration cards been filled out and mailed to the factory?
9. Check all refrigerant and conduit lines to guard against vibration and possible failure.
10. Installed in a well ventilated room where ambient temperatures do not fall below 50 degrees Fahrenheit.
11. Is unit installed with a minimum 4" air space around sides and back?

SERVICE

STARTING THE MACHINE:

When the machine is placed and inspected as per instructions and all plumbing and electrical connections are completed and tested, turn on the water supply. Be sure the float cover is removed to check on the float operation and water level in the water reservoir. Be sure the water reservoir is filled before starting the machine. Water level should be 1/4 inch below the reservoir overflow.

When this is completed, turn on the manual switch on the front of the cabinet and the machine is in automatic operation. In two to three minutes ice will start dropping off the worm shaft and out the ice chute. Let the machine operate for at least 30 minutes and check for any excess noise other than the normal compressor noise.

Check pressure settings at the time of start-up. On the water-cooled models set the head pressure at 135 PSI. On the air-cooled models the head pressure will vary between 130 and 145 PSI head pressure. The frost line should extend out of the accumulator if properly charged with refrigerant and suction pressure will range between 14 and 16 PSI with 50 degrees Fahrenheit inlet water.

Check the hand reset low pressure control setting. This safety device should be set at approximately 2 PSI and should cut off in case of interruption in water supply, shortage of refrigerant, low ambient or any other cause of abnormally low suction pressure.

REFRIGERANT SYSTEM:

The standard Scotsman Flaker system is used in slightly modified form. Refrigerant 12 is pumped by compressor into the air cooled condenser, into the liquid line, thru a filter-drier and then into the capillary refrigerant control line.

Liquid refrigerant is then carried down to the bottom end of the shell and tube type evaporator (freezing cylinder) where it expands and rises to the top of evaporator. Here the vapors and gases are returned thru an accumulator and suction line to the compressor.

REFRIGERANT CHARGE:

The below refrigerant charge is approximate. When charging, set at 135 PSI (water cooled) or 145 PSI (Air Cooled) and charge so that the frost line extends out of the evaporator and into the accumulator after fifteen minutes of operation.

<u>Model</u>	<u>Refrigerant Charge</u>
Air Cooled	33 oz. R-12
Water-Cooled	33 oz. R-12

REFRIGERATION CYCLE FD7

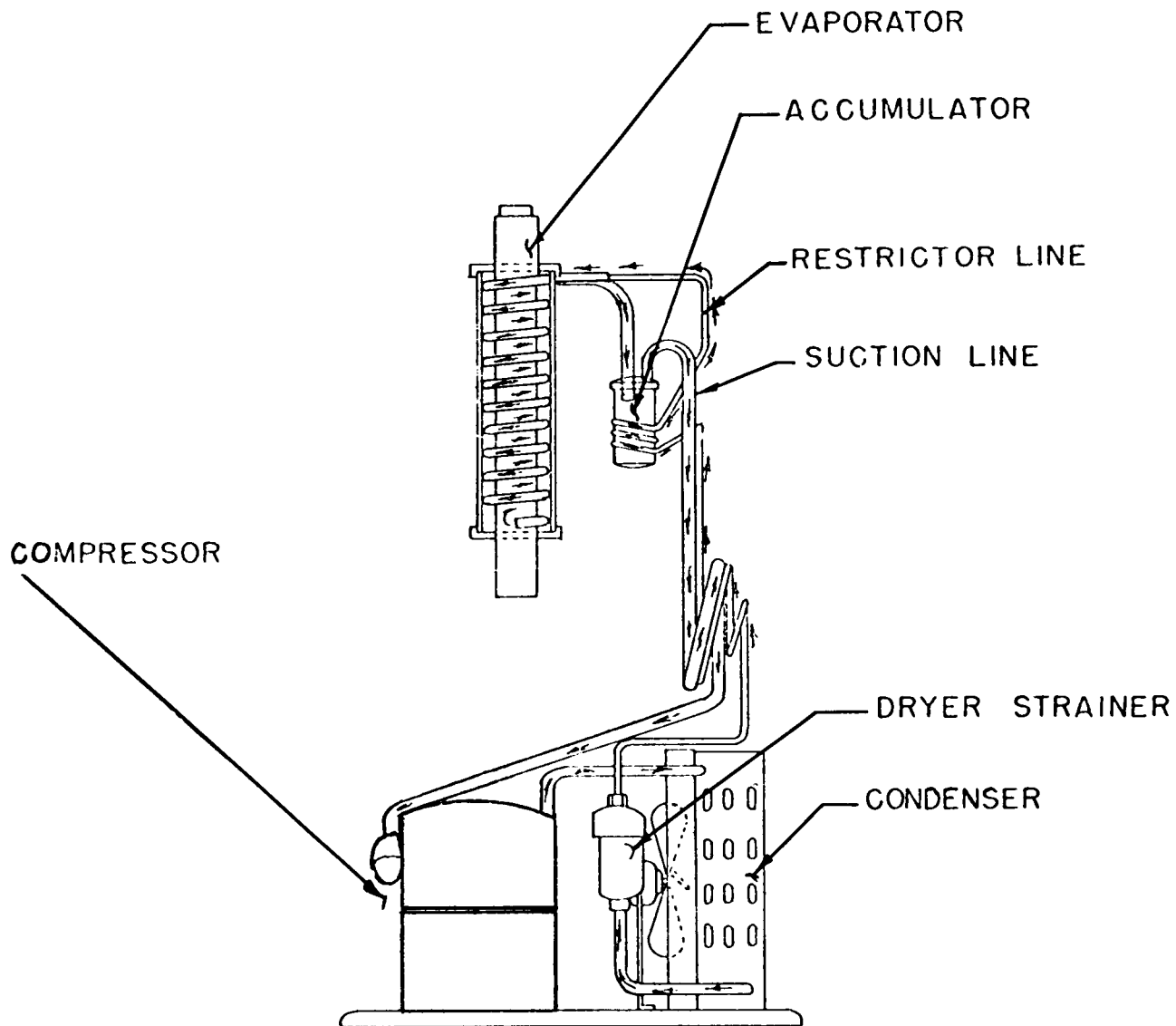

WIRING DIAGRAM (AIR COOLED) A24891-001

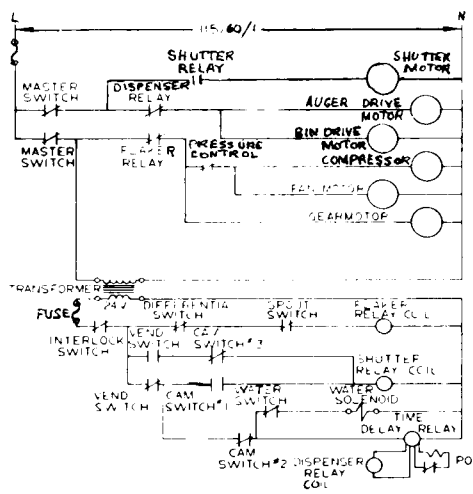
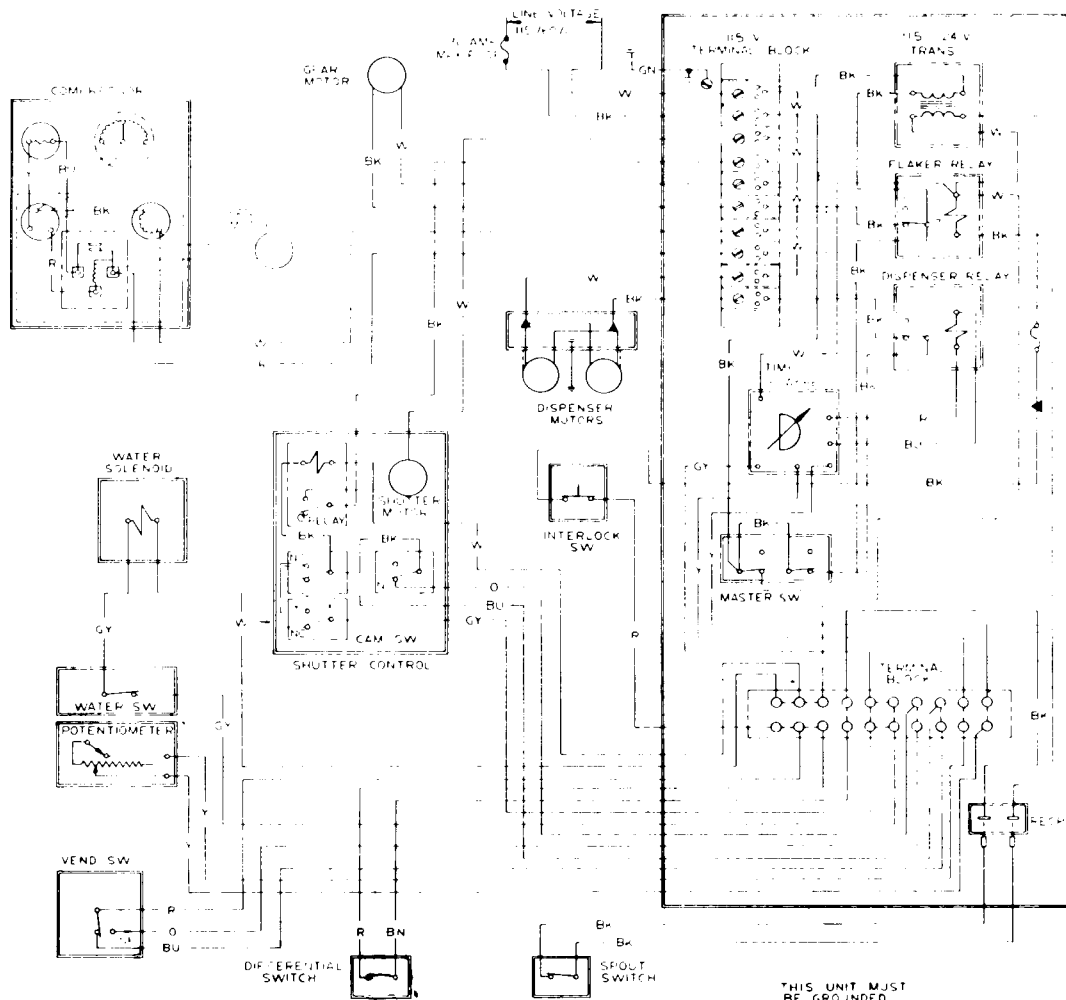

THIS UNIT MUST BE GROUNDING

NOTE: THE SHUTTER RELAY AND DISPENSER RELAY ARE INTERLOCKED TO PREVENT THE SHUTTER MOTOR FROM OPERATING WHILE THE DISPENSER MOTOR IS RUNNING.

DURING OPERATION THE PRESSURE CONTROL SHOULD BE KEPT IN THE OFF POSITION.

CAUTION: THE WATER SOLLENOID SHOULD NOT BE OPERATED FOR MORE THAN 30 SECONDS.

THE DEF. POSITION ON THE 2 ARE NOT TO BE USED.

A24891-001

WIRING DIAGRAM (WATER COOLED) A24890-001

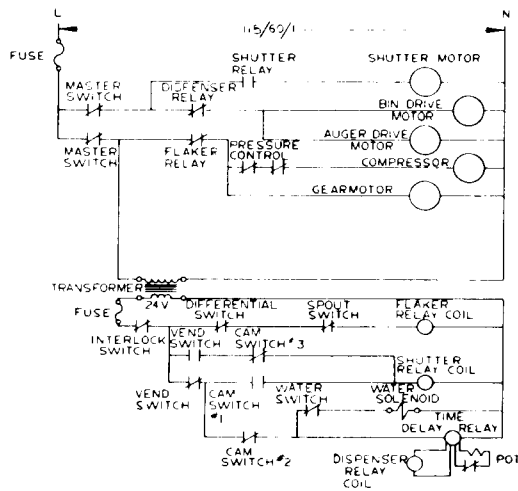
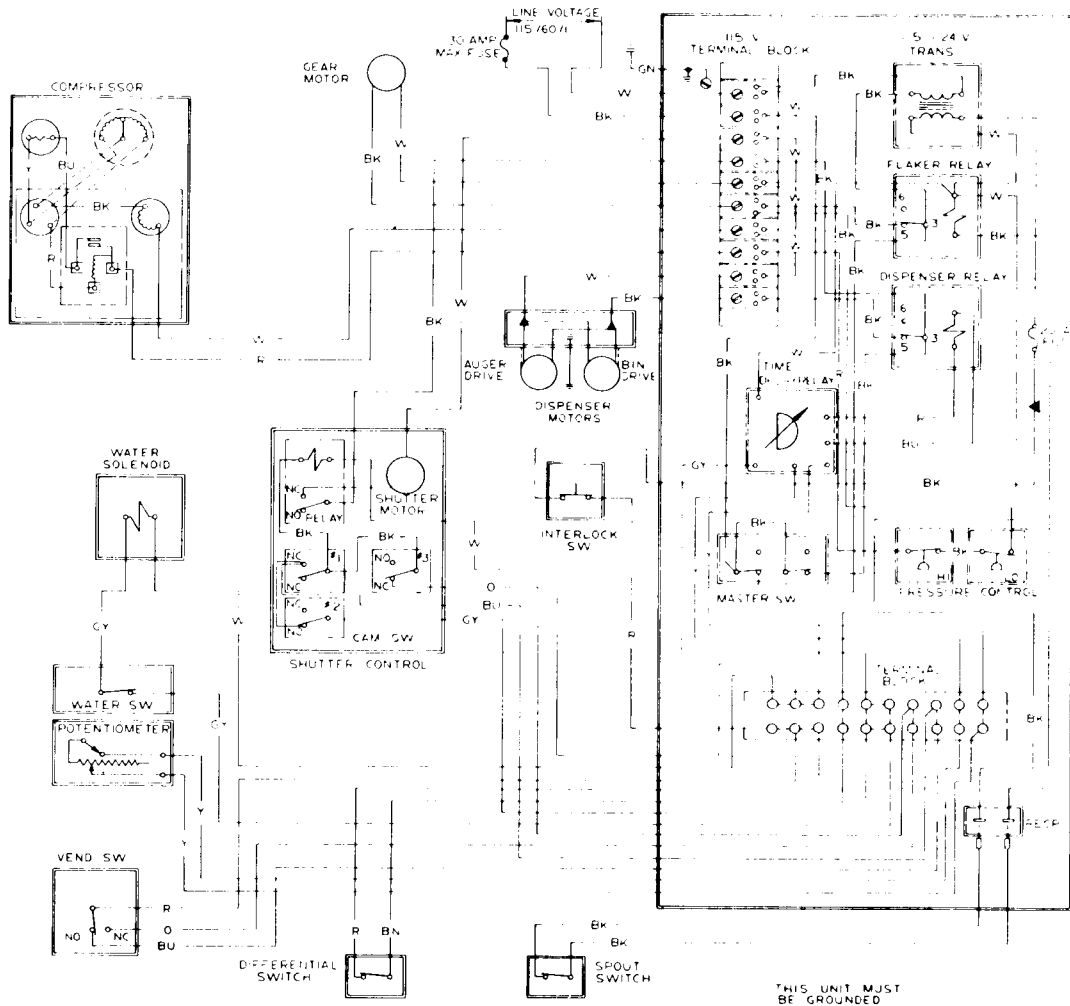

SERVICE ANALYSIS CHART

COMPLAINT	POSSIBLE CAUSE	CORRECTION
<p>When actuating arm is pushed, shutter does not open.</p>	<p>Actuator not depressing switch plunger.</p> <p>Loose thumb nuts.</p> <p>Defective actuator switch.</p> <p>Shutter rubbing on plastic bin liner.</p> <p>Actuator rod bent.</p> <p>Actuator motor, cam or switch No. 1 defective or out of adjustment.</p> <p>Shutter motor relay defective.</p>	<p>Check actuator switch. Must be adjusted down to contact activator lever</p> <p>Tighten thumb nuts holding actuator arm to mounting plate.</p> <p>Replace switch.</p> <p>Remove shutter and install washer on shaft to raise shutter.</p> <p>Replace rod or check set screw on motor cam. Do not attempt to bend rod for an adjustment.</p> <p>Replace or adjust. (See page 16 for adjustment.)</p> <p>Check and replace if necessary.</p>
<p>When actuating arm is pushed shutter opens but machine will not vend.</p>	<p>Cam switch of shutter control box out of adjustment or defective.</p> <p>Vend relay in control box inoperative.</p> <p>Vend switch out of adjustment or defective.</p> <p>Timing module in control box open.</p> <p>Bin or discharge auger motors inoperative.</p> <p>Ice jammed in discharge spout.</p> <p>Pin attaching bin drive hub to motor sheared.</p>	<p>Adjust or replace.</p> <p>Check and replace.</p> <p>Adjust or replace (See page 30 for adjustments).</p> <p>Check and replace if necessary.</p> <p>Remove bin and check.</p> <p>Remove discharge auger and clear ice from spout and auger.</p> <p>Check and replace if found sheared. (Refer to Item No. 15 page 19).</p>
<p>Dispenser auger will not turn.</p>	<p>Drive on end of auger sheared.</p> <p>Gearmotor defective</p>	<p>Remove auger, replace drive.</p> <p>Replace gearmotor.</p>
<p>Vend relay energized but machine will not dispense ice.</p>	<p>Contacts on relay bent or wires to relay loose.</p> <p>Dispenser motors defective.</p>	<p>Replace relay or tighten connections.</p> <p>Repair or replace. These motors have an internal thermo overload - automatic reset.</p>
<p>Portion control will not work. Runs continuous when actuator is held on.</p>	<p>Timing module defective.</p> <p>Potentiometer switch defective.</p> <p>Loose connection or open wires to potentiometer.</p>	<p>Replace module.</p> <p>Replace Potentiometer</p> <p>Check terminal wires.</p>

SERVICE ANALYSIS CHART

COMPLAINT	POSSIBLE CAUSE	CORRECTION
Will not dispense water when water switch is activated.	Defective water switch. Defective water solenoid. Water line restricted.	Replace switch. Replace solenoid located behind control panel. Clean.
Shutter motor will not stop. Shutter opens and closes.	Cam switches out of adjustment	Adjust (See page 16).
Machine runs but doesn't make ice.	Water not entering freezing chamber. Loss or undercharge of refrigerant. Moisture in system. Water seal leaking.	Plugged strainer or supply line. Check and clean. Air lock in gravity feed line. Check and remove air lock. Check for leaks and recharge. Check and remove charge and drier. Replace and recharge. Replace seal.
Water leaks.	Defective water seal. Gravity feed line leaking. "O" ring in spout casting leaking. Water level in reservoir too high.	Replace. Check hose clamps and tubing. Remove spout casting and install new "O" ring. Adjust to 1/4" below overflow pipe.
Excessive noise or chattering.	Scale or mineral build-up on inside of freezer or on auger. Low suction pressure. Intermittent water supply. Water level in reservoir too low. Gearmotor endplay or worn bearings. Gearmotor loose on frame.	Ice sticking and jamming inside. Clean with Ice Machine Cleaner or remove and manually polish auger and inner chamber walls of freezer barrel. Raise suction pressure. Adjust head pressure control to recommended setting or balance refrigerant charge. Check and clean water strainer. Check gravity feed line for air lock. Remove air lock. Adjust to 1/4" below overflow pipe. Repair or replace. Tighten.
Low ice production.	Loss of refrigerant. Under or over-charge of refrigerant. Drive motor weak. Dirty or plugged condenser. Low water level in water reservoir.	Check and recharge with proper amount of refrigerant. Replace. Clean condenser. Adjust to 1/4" below overflow pipe.

SERVICE ANALYSIS CHART

COMPLAINT	POSSIBLE CAUSE	CORRECTION
Low ice production. Continued.	<p>Partial restriction in capillary tube or drier.</p> <p>Inlet water strainer partially plugged.</p> <p>Corroded or stained worm shaft due to water condition.</p>	<p>Moisture in system. Overcharge of oil in system. Remove charge by blowing back through cap tube, Replace and recharge.</p> <p>Remove screen and clean.</p> <p>Remove worm shaft and clean, or use Ice Machine Cleaner. See Maintenance Section.</p>
Machine continues to run with full storage bin.	Storage bin controls are defective.	Replace.
Squeal in freezer.	Too hard ice.	<p>Increase water level in reservoir.</p> <p>Check low side pressure and adjust if necessary.</p>
Machine will not operate.	Low or high pressure controls open.	Reset button. Check why controls have activated.

CLEANING DISPENSER MECHANISM

Cleaning of the dispenser mechanism should be accomplished every three months. This unit can be disassembled for cleaning without the use of tools.

1. Dispense all the ice from the bin.
2. Open top front door. This disconnects the flaker as well as the dispensing unit from the electrical power as safety switch is no longer held closed by the door.
3. Remove the front end plate from the auger by lifting the two lock arms.
4. Remove ice auger by pulling straight out.
5. Remove spout pin and remove electrical plug connected from the spout switch to control box.
6. Lift spout from the unit.
7. Remove cap nut from shaft in storage bin.
8. Lift off revolving storage bin and remove from the storage compartment.
9. Remove wing nuts at base of stationary bottom and lift out of storage compartment.
10. To assemble proceed in the same reverse order. Be sure the electrical plugs from the ice spout are inserted in the receptacle on top of the dispenser control box.
11. The ice auger must be turned until it engages with the output coupling of the gear unit when it is reinstalled.

MAINTENANCE INSTRUCTIONS FOR ICE MAKER SECTION

Combine this service with cleaning of dispenser section if possible.

The following services must be accomplished a minimum of two (2) times per year on all Ice Makers.

1. Check and clean water strainers and float valve. Depress float valve to insure full stream of water.
2. Check water level and machine level, keep water level below overflow, but as high as possible and still not run out of spout opening with machine off. Water should come out of spout with ice at all times.
3. Clean reservoir and interior of freezer using SCOTSMAN Ice Machine Cleaner.
 - A. If machine has been cleaned regularly and no problems such as dry ice or chatter are noticed, clean by making ice from solution of 8 oz. of cleaner to 1 gal. warm water.
 - B. If heavy mineral deposits on auger and walls, or sediment at inlet to freezer are encountered, clean by pouring strong solution (1/2 acid - 1/2 water) into reservoir and operate drive motor only for agitation. Allow 1/2 hour or longer as required. Drain by disconnecting tygon at water inlet to freezer.

NOTE: Cleaning requirements vary according to local water conditions. Visual inspection of the auger before and after cleaning will indicate best procedure to be followed in local areas.

ICE SHUTTER CONTROL SCHEMATIC

TO OPEN & CLOSE THE ICE DISCHARGE SPOUT

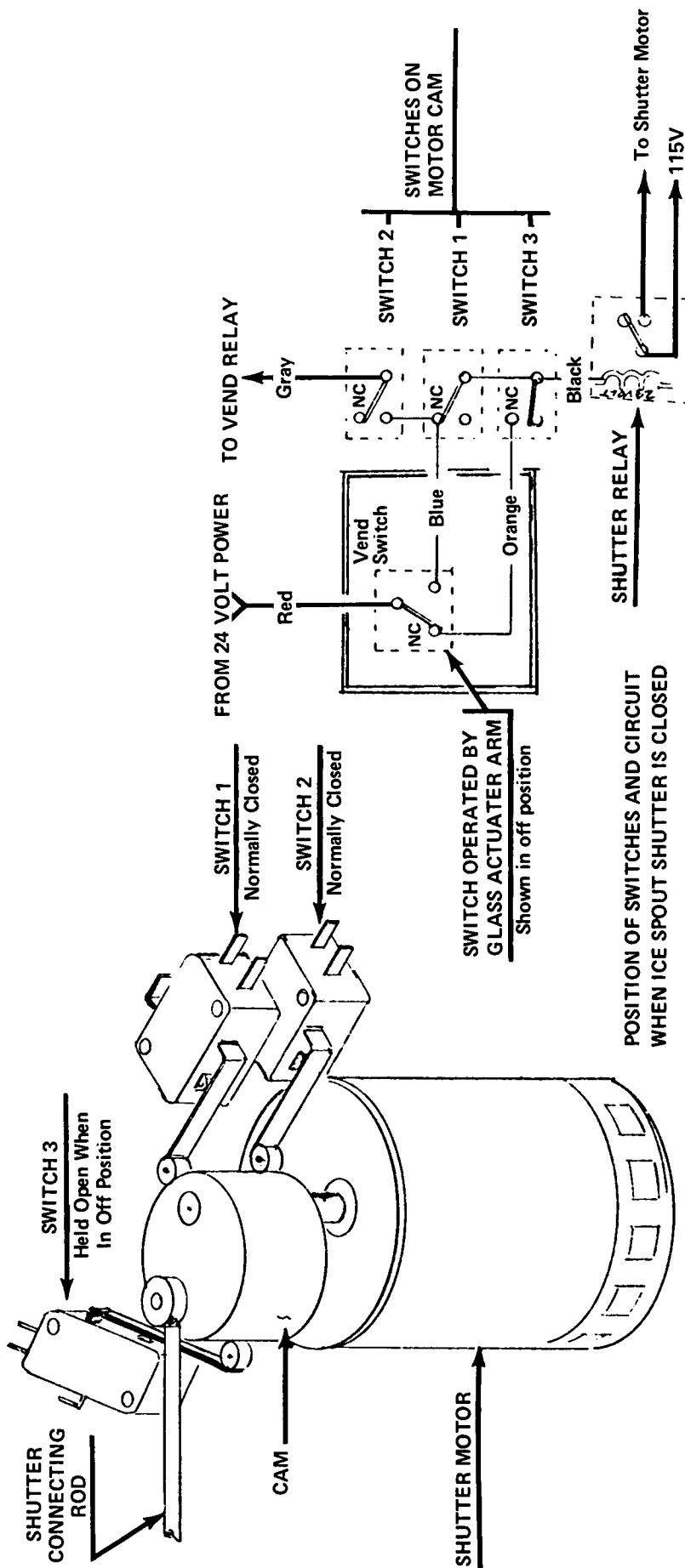

POSITION OF SWITCHES AND CIRCUIT WHEN ICE SPOUT SHUTTER IS CLOSED

SWITCH 2 HOLD ICE VEND OFF UNTIL SHUTTER IS OPEN
 SWITCH 1 OPENS THE SHUTTER
 SWITCH 3 CLOSES THE SHUTTER

NOTE: If pressing the glass filler fails to initiate a vend cycle, it is possible one of the micro switches is out of adjustment. Switch No. 2 must be closed to start the cycle. If the shutter will not open, adjust switch No. 1. If the shutter will not close, adjust switch No. 3.

FREEZER GEARMOTOR

The FD7 is equipped with a 1/4 horsepower direct drive gear reducer.

TO REPLACE:

1. Disconnect electrical power and shut off water supply to the unit.
2. Remove the top and left side panels.
3. Disconnect the electrical led to the gearmotor at the control box.
4. Remove the water line from reservoir and drain freezer.
5. Open right front door and disconnect the spout by removing the locking pin. Pull enough cord through the opening to set the spout in the bin.
6. Remove the two bolts holding the freezer bracket at the top of the tube to the inner wall.
7. Remove the three bolts holding the adaptor to the gear reducer.
8. Lift the freezer up and remove the coupling.
9. Remove the three bolts from the bottom of the frame holding the gear reducer to the chassis.
10. Remove gear reducer from machine.
11. Reverse procedure to replace unit.

FREEZER ASSEMBLY

TO REPLACE:

1. Disconnect electrical power and shut off water supply to unit.
2. Remove top and left side panel.
3. Remove tygon tubing from bottom of freezer and drain water from machine.
4. Open right front door and disconnect spout by removing the locking pin. Pull enough cord through the opening to set the spout in the bin.
5. Purge off refrigerant and disconnect flare nuts at drier and suction Rotolock valve.
6. Remove the three bolts securing the freezer base adaptor to the gear reducer. Lift freezer and remove coupling.
7. Remove four screws from corner brace. (Number 37, side view, Air and Water Cooled)
8. Pull freezer assy from machine being careful not to kink the suction line or cap tube.
9. Reverse procedure to replace unit.

FREEZER WORM SHAFT (AUGER)

TO REPLACE:

1. Disconnect electrical power and shut off water supply to unit.
2. Remove top and left side panels.
3. Remove tygon tubing from bottom of freezer and drain water from machine.
4. Remove two stainless steel screws from the top rear portion of freezer ass'y.
5. By lifting up on the freezer cap pull ring, the complete worm shaft and upper bearing retainer can be removed. NOTE: The top half of the water seal is attached to the lower end of the auger.

FREEZER ASSEMBLY TOP BEARING

TO REPLACE:

1. Follow steps 1 thru 5, freezer worm shaft removal.
2. Remove cap ring and freezer cap from bearing retainer.
3. Remove cap screw and washer holding shaft to inner race of bearing and pull worm shaft from bearing and retainer.
4. Remove snap ring and pull bearing from retainer.
5. Reverse steps to re-install.
6. When replacing with a new bearing, add new grease. (Beacon No. 325)

FREEZER ASS'Y BOTTOM BEARING AND WATER SEAL

TO REPLACE:

1. Follow steps 1 thru 5, freezer worm shaft removal.
2. Remove 3 bolts holding freezer to mounting adaptor.
3. Lift freezer off adaptor enough to allow bottom bearing and bottom half of water seal to be removed from freezer tube.
4. Lightly grease bottom half of new water seal and insert face up approximately 1/2" in freezer tube.
5. Insert bottom bearing in bottom of freezer tube. Force approximately 1/8" past tube end. This will allow the positioning ring on the adaptor to properly position the bearing in the tube when the three mounting bolts are replaced.
6. After securing the three mounting bolts, put new top half of water seal on worm shaft. When reassembling, put a small amount of vaseline on the shaft end. This will allow the shaft to slide through the rubber on the water seal without tearing it.
7. Carefully insert worm shaft in freezer tube and into coupling on bottom.
8. Replace 2 stainless steel screws on back of freezer ass'y.

BIN FULL SWITCH

The level of ice in the bin is controlled by the bin full switch located in the top center of the bin compartment. As the ice level increases, it pushes the stainless steel paddle back, depressing the cut off switch. As the ice is dispensed, the paddle falls forward, re-starting the freezing cycle. Should this switch fail to shut the machine off when the bin is full, the ice will back up into the discharge spout. The pressure created in the spout ass'y will depress the spout plate switch, shutting off the machine. This provides a back up or safety device to prevent the ice from backing all the way to the freezer ass'y and causing damage to freezer or gearmotor components.

TO REPLACE:

1. Disconnect electrical power to the unit.
2. Remove top panel.
3. Open right front door and remove hex nut holding switch in place. Also remove 4 screws holding cover down.
4. Remove and replace switch, remount cover and hinge ass'y, replace hex nut on switch.
5. Turn on machine and check switch operation.

WATER RESERVOIR

The water level is maintained in the reservoir by a float operated valve. Water is piped from the water reservoir to the freezing chamber by a gravity feed line maintaining an equal water level.

The reservoir is equipped with a 2 inch air gap to prevent back siphoning and meet all health codes.

The water level in the reservoir is adjusted by bending the float arm. The water level should be set approximately 1/4 inch below the overflow stand pipe.

A water strainer must be installed in the supply line. A strainer is provided with each machine.

TO REPLACE:

1. Remove cabinet top and left side panel.
2. Turn off water supply and drain reservoir.
3. Remove 1/4 inch inlet water line.
4. Remove tygon feed line to freezer.
5. Remove two screws holding reservoir bracket to wall.
6. Lift out reservoir.
7. To replace, reverse procedure.

HEAD PRESSURE CONTROL, WATER COOLED

This safety device is mounted in the control box behind the left side door. It is a manual reset control with an adjustment screw for raising or lowering the cut-out pressure. This control is preset at the factory for 190 PSIG. It will shut off the machine if the head pressure exceeds this point. Usually, this condition is caused by the water being cut off to the condenser.

LOW PRESSURE CONTROL – AIR & WATER COOLED

This is a manual reset, safety device designed to cut off the machine if the back pressure drops below 5 PSIG. This situation could be caused by loss of water in the freezer, low refrigerant or low ambient temperatures. Other conditions could also exist which would lower the back pressure and damage the machine if it continued to run.

WATER REGULATING VALVE (WATER COOLED MODELS ONLY)

The water Regulating Valve is designed to maintain a constant head pressure by regulating the amount of incoming water flow through the water cooled condenser. This valve is operated by high side pressure and may be adjusted by the adjusting screw on top of the valve to raise or lower the operating head pressure.

TO REPLACE:

1. Shut off water supply to machine and disconnect electrical power.
2. Disconnect old valve from water supply line and install new valve.
NOTE: Be sure arrow on side of valve points in direction of water flow.
3. Purge off refrigerant and disconnect valve capillary line from high side fitting and immediately attach capillary from new valve.
4. Recharge system. Refer to page 8 for proper refrigerant charge and head and back pressure settings.

BIN AND AUGER DRIVE UNIT ASS'Y

TO REPLACE:

1. Disconnect electrical power to unit.
2. Unplug spout at control box. Remove locking pin and pull spout out of compartment.
3. Pull hinge pin and remove stainless steel shut off arm from ice level control ass'y.
4. Remove bin locking cap and lift out bin.
5. Press out pin (item 15, page 25) and remove hub drive. (item 5, page 25)
6. Remove end plate ass'y (item 42, page 20) pull out auger.
7. Remove hold down nuts on stationary bottom and lift out.
8. Disconnect wires to drive unit.
9. Remove screws and lift off motor cover.
10. Remove 4 screws and pull out auger drive motor. (Horizontal shaft, 56 RPM)
11. Turn mounting plate over and remove screws holding bin support (item 12, page 25)
12. Remove screws and lift out bin drive motor. (perpendicular shaft, 2 RPM)

NOTE: WHEN REMOUNTING BIN DRIVE MOTOR, DO NOT TIGHTEN SCREW COMPLETELY. THE MOTOR IS DESIGNED TO HANG FREE UNDER THE BIN SUPPORT. LEAVE 1/4" GAP BETWEEN THE MOTOR MOUNT POSTS AND THE BIN SUPPORT.

FD7 FRONT VIEW
(Air Cooled)

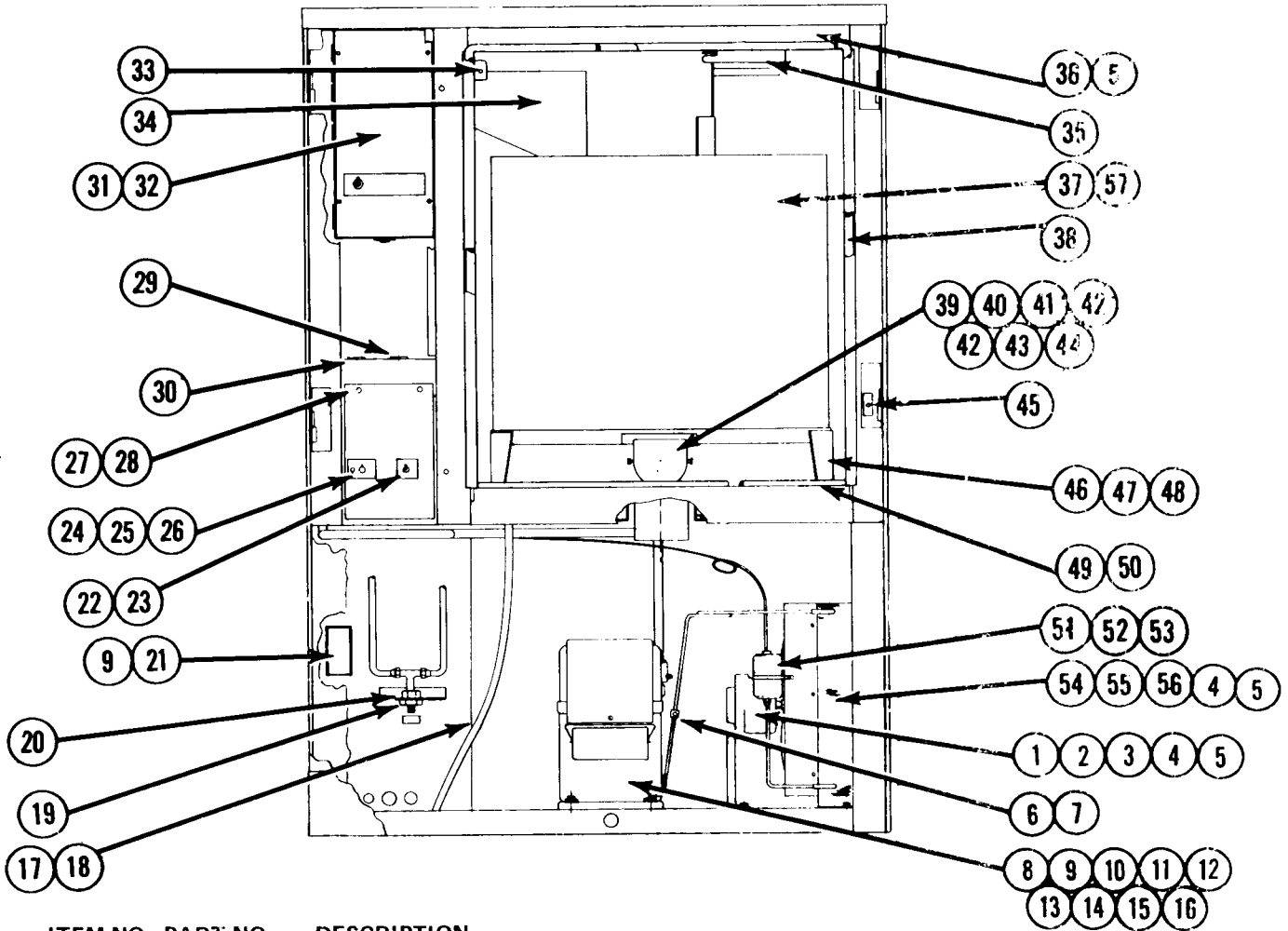

ITEM NO. PART NO. DESCRIPTION

1.	18-0363-00	Blade, Fan	29.	12-1213-13	Snap Bushing
2.	18-0388-00	Bracket, Fan	30.	12-1213-15	Snap Bushing
3.	12-1576-01	Fan Motor	31.	03-1404-08	Screw
4.	03-1405-03	Screw	32.	A23769-001	Cover, Control Box
5.	03-1417-09	Washer	33.	A14926-000	Locking Pin, Spout
6.	16-0563-00	Cap, Brass	34.	See page 26	Spout Ass'y
7.	16-0560-00	Valve Core	35.	See page 28	Switch Ass'y
8.	18-3500-01	Compressor	36.	03-1403-47	Screw
	18-2200-25	Overload	37.	A14945-000	Storage Bin
	18-3520-00	Relay	38.	A24624-001	Gasket
	18-1901-33	Capacitor	39.	03-1409-12	Washer
9.	12-1213-10	Snap Bushing	40.	A14932-000	Chute Lock
10.	18-2200-27	Sleeve	41.	A16766-000	Ice Auger Ass'y
11.	18-2200-28	Grommet	42.	A14933-000	End Plate Ass'y
12.	18-2201-30	Valve, Suction, Rotolock	43.	03-1408-09	Washer
13.	18-2300-29	Seal, Valve	44.	03-1129-00	Cap Nut
14.	03-1417-12	Washer	45.	12-1276-00	Switch
15.	03-1405-20	Screw	46.	See Page 25	Drive Unit Ass'y
16.	03-1408-02	Washer	47.	A24294-001	Stationary Bottom
17.	A16173-008	Drain Tube	48.	03-1235-00	Wing Nut
18.	02-1338-00	Clamp	49.	13-0765-01	Gasket
19.	03-1394-01	Nut	50.	A24350-001	Trim Channel
20.	A24625-001	Water Inlet Ass'y	51.	02-0544-00	Drier
21.	12-0901-00	Cover	52.	A09388-001	Brace, Drier
22.	15-0556-01	Water Decal	53.	03-1404-15	Screw
23.	12-0426-01	Toggle Switch	54.	A23754-001	Condenser
24.	15-0555-01	Ice Decal	55.	A23825-001	Shroud
25.	02-1810-00	Potentiometer Knob	56.	03-1404-03	Screw
26.	12-1557-00	Potentiometer	*57.	02-1587-00	Bin Locking Cap
27.	03-1404-09	Screw			
28.	A24259-001	Switch Mount			

* Not Shown

SIDE VIEW – AIR & WATER

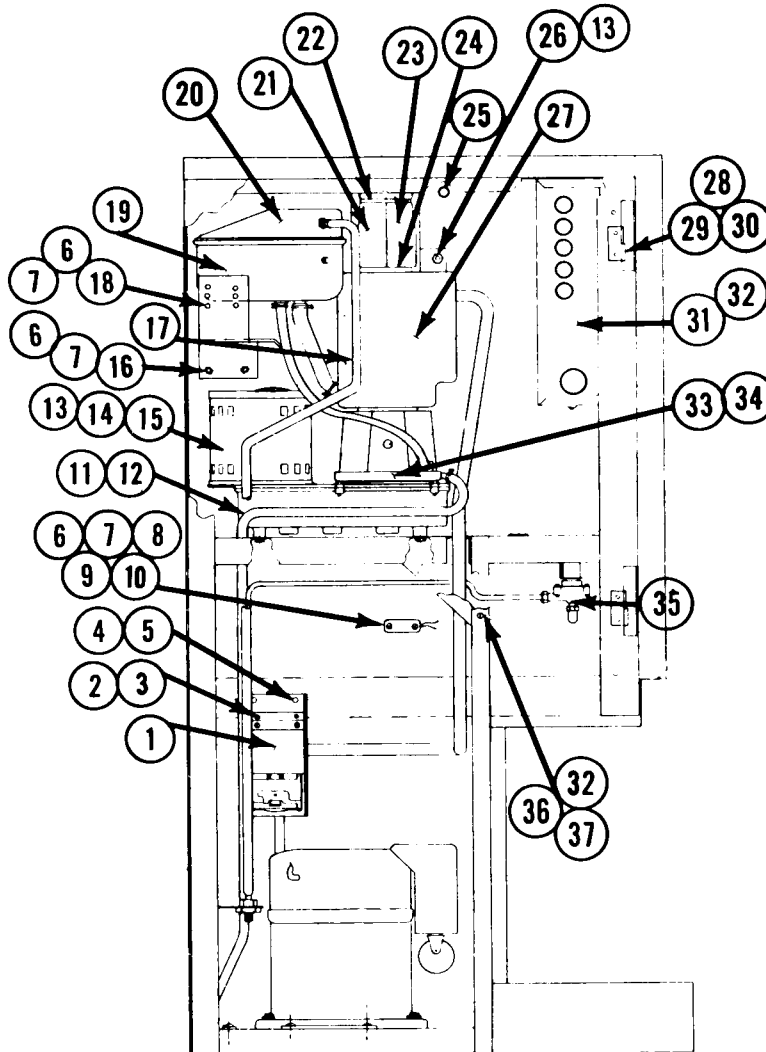

ITEM NO.	PART NO.	DESCRIPTION	ITEM NO.	PART NO.	DESCRIPTION
1.	See Page 18	Shutter Actuator Assy.	24.	02-1438-00	Clip, Insulation
2.	03-1404-05	Screw	25.	12-1213-04	Snap Bushing
3.	A21226-000	Cover	26.	03-1406-10	Nut
4.	03-1417-09	Washer	27.	A23518-001	Freezer Ass'y
5.	03-1403-47	Screw	28.	03-1407-04	Washer
6.	03-1403-28	Screw	29.	15-0543-03	Hinge, Rt
7.	03-1417-05	Washer		15-0543-01	Hinge, Left
8.	12-0184-01	Splice cap	30.	03-1403-25	Screw
9.	A24286-001	Junction Box Ass'y	31.	A23697-001	Control Box, Air Cooled
10.	12-0901-00	Cover		A24195-001	Control Box, Water Cooled
11.	A21002-003	Drain Tube	32.	03-1403-17	Screw
12.	02-0534-00	Clamp	33.	03-1420-03	Screw
13.	03-1410-04	Washer	34.	03-1408-03	Washer
14.	03-1405-18	Screw	35.	A24527-007	Solenoid
15.	A22750-001	Gear Motor	36.	03-1417-03	Washer
16.	A24339-001	Reservoir Mount	37.	A23731-001	Corner Brace
17.	A23751-001	Water Line			
18.	03-1406-06	Nut			
19.	A23410-011	Reservoir Ass'y			
20.	A16012-000	Cover			
21.	A17890-000	Insulation, Spout, Lt.			
22.	A08733-000	Strap, Insulation			
23.	A17891-000	Insulation, Spout, Rt.			

FRONT VIEW (Water Cooled)

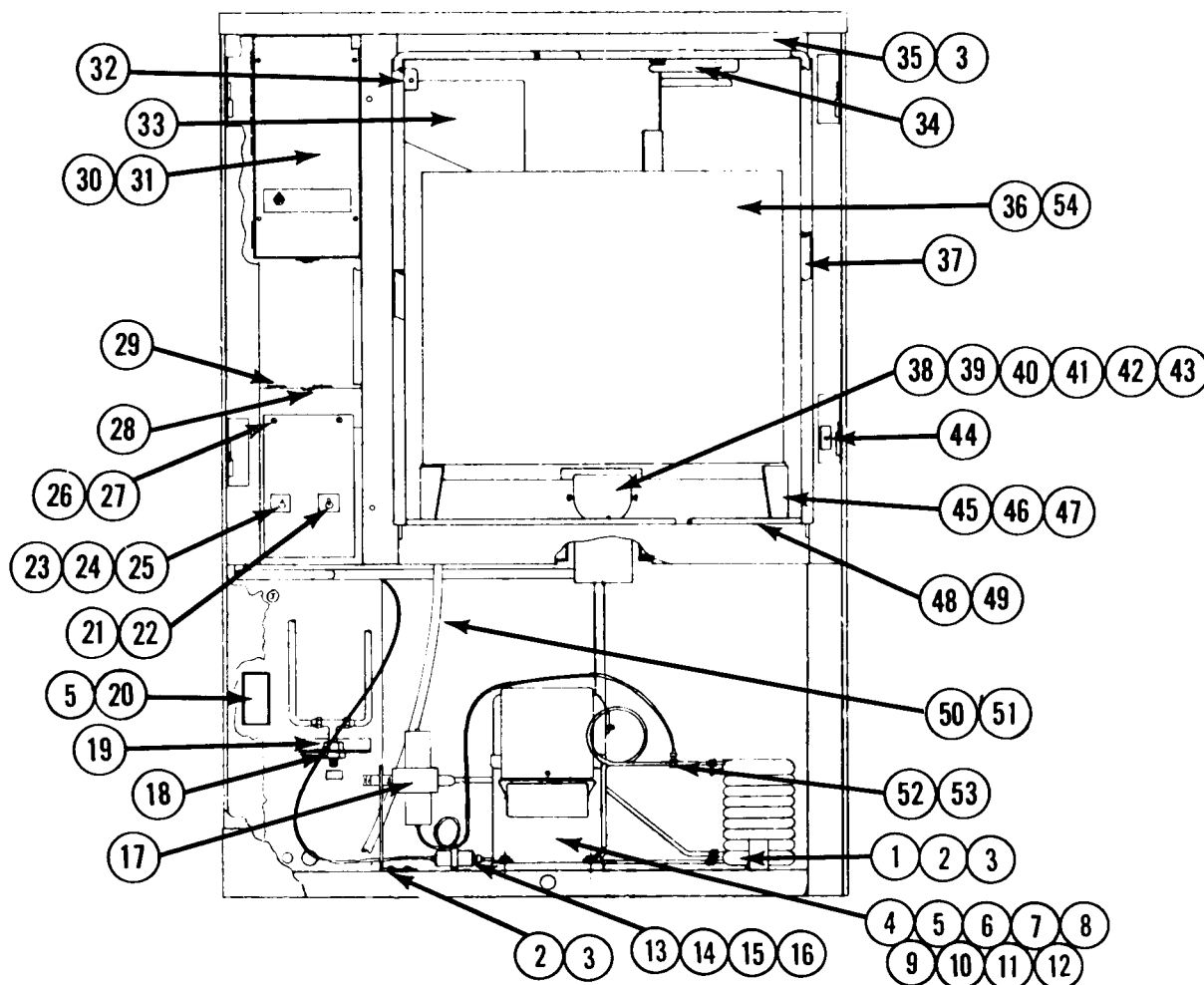

ITEM NO. PART NO. DESCRIPTION

1.	18-1305-01	Condenser	26.	A24259-001	Switch Mount
2.	03-1405-03	Screw	27.	03-1404-09	Screw
3.	03-1417-09	Washer	28.	12-1213-13	Snap Bushing
4.	18-3500-01	Compressor	29.	12-1213-15	Snap Bushing
	18-2200-25	Overload	30.	03-1404-08	Screw
	18-3520-00	Relay	31.	A23769-001	Cover, Control Box
	18-1901-33	Capacitor	32.	A14926-000	Locking Pin, Spout
5.	12-1213-10	Bushing	33.	See Page 26	Spout Ass'y
6.	18-2200-27	Sleeve	34.	See Page 28	Switch Ass'y
7.	18-2200-28	Grommet	35.	03-1403-47	Screw
8.	18-2201-30	Valve, Suction Rotolock	36.	A14945-000	Storage Bin
9.	18-2300-29	Seal, Valve	37.	A24624-001	Gasket
10.	03-1417-12	Washer	38.	03-1409-12	Washer
11.	03-1405-20	Screw	39.	A14932-000	Chute Lock
12.	03-1408-02	Washer	40.	A16766-000	Ice Auger Ass'y
13.	A09388-01	Brace, Drier	41.	A14933-000	End Plate Ass'y
14.	02-0544-00	Drier	42.	03-1408-09	Washer
15.	03-1405-03	Screw	43.	03-1129-00	Cap Nut
16.	03-1417-09	Washer	44.	12-1276-00	Switch
17.	11-0198-00	Water Regulator	45.	See Page 25	Drive Unit Ass'y
18.	03-1394-00	Nut	46.	A24294-001	Stationary Bottom
19.	A24625-001	Water Inlet Ass'y	47.	03-1235-00	Wing Nut
20.	12-0901-00	Cover	48.	A24350-001	Trim Channel
21.	15-0556-01	Water Decal	49.	13-0765-01	Gasket
22.	12-0426-01	Toggle Switch	50.	A16173-008	Drain Tube
23.	15-0555-01	Ice Decal	51.	02-1338-00	Clamp
24.	02-1810-00	Potentiometer Knob	52.	16-0563-00	Brass Cap
25.	12-1557-00	Potentiometer	53.	16-0560-00	Valve Core
			*54.	02-1587-00	Bin Locking Cap

FREEZER ASSEMBLY
A23518-020

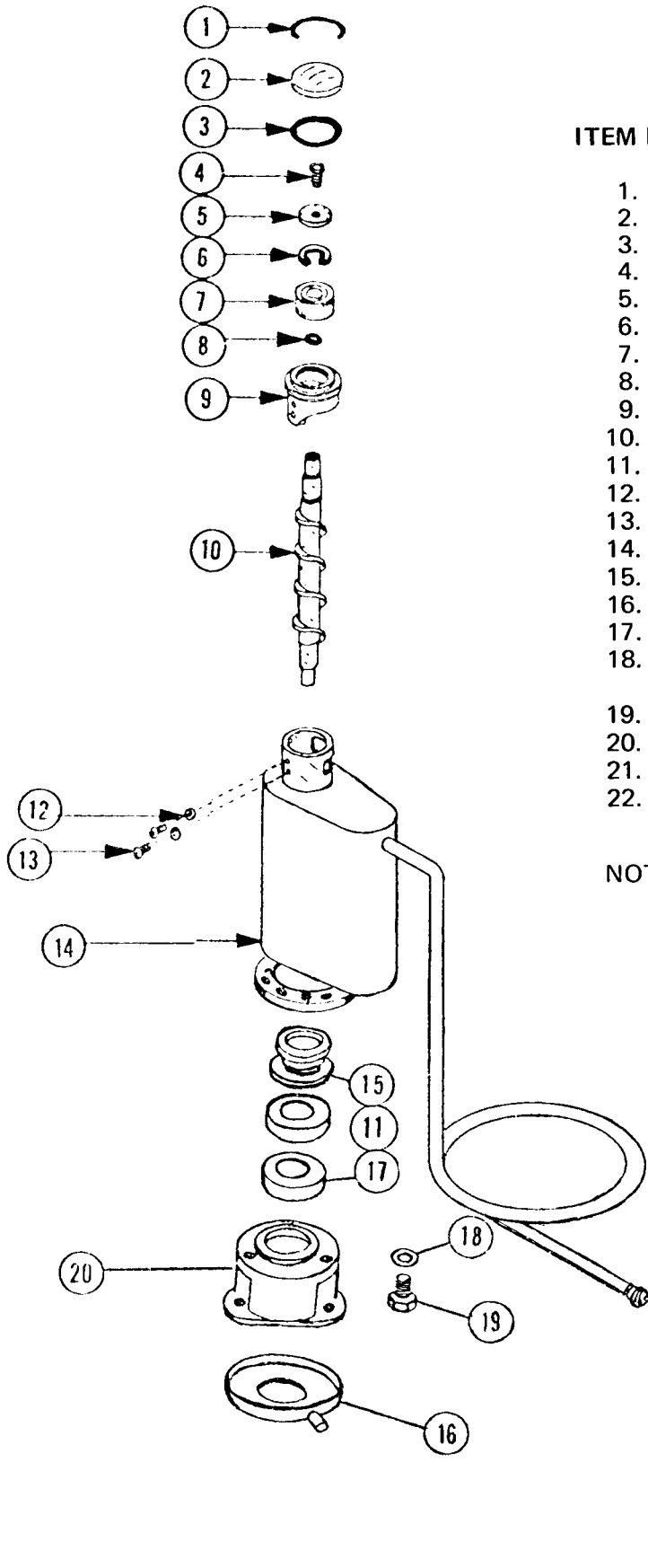

ITEM NO.	PART NO.	DESCRIPTION
1.	A08582-000	Cap Hook
2.	A08581-000	Cap
3.	13-0617-20	"O" Ring
4.	03-1405-36	Cap Screw
5.	A06273-000	Washer
6.	03-712-00	Snap Ring
7.	02-0646-00	Bearing
8.	13-0617-15	"O" Ring
9.	A08316-000	Breaker
10.	02-0617-00	Auger
11.	02-0619-00	Bearing
12.	03-1410-03	Washer (2)
13.	03-1403-48	Screw (2)
14.	A23519-020	Freezer Fab. Ass'y
15.	02-0929-00	Water Seal
16.	A24156-001	Drip Pan
17.	A10591-000	Bearing Retainer
18.	03-1410-04	Lockwasher
	03-1408-03	Washer
19.	03-1405-41	Screw
20.	02-1629-00	Adapter
21.	15-0573-01	Drive Coupling
22.	13-0704-00	Shaft Drip Shield Rubber

NOTE: Items 16, 21, and 22 do not come with Freezer Assembly.

GEAR MOTOR ASSEMBLY
A22750-021

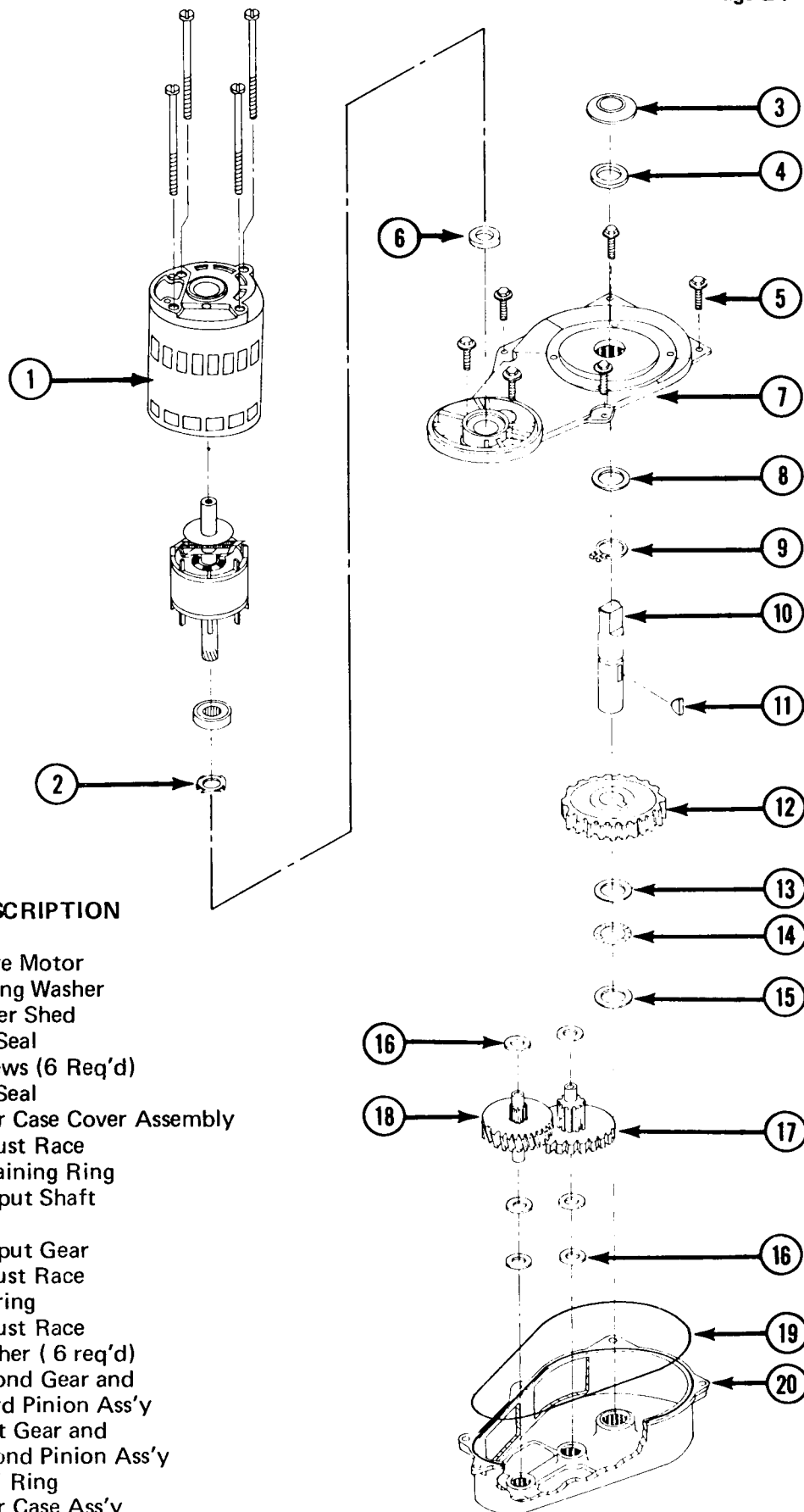

ITEM NO.	PART NO.	DESCRIPTION
1.	12-1741-01	Drive Motor
2.	03-1426-00	Spring Washer
3.	13-0709-02	Water Shed
4.	02-1607-00	Oil Seal
5.	03-1251-00	Screws (6 Req'd)
6.	02-1606-00	Oil Seal
7.	A22200-000	Gear Case Cover Assembly
8.	02-1681-00	Thrust Race
9.	03-1363-00	Retaining Ring
10.	02-1652-00	Output Shaft
11.	03-1364-00	Key
12.	02-1653-00	Output Gear
13.	02-1681-00	Thrust Race
14.	02-1680-00	Bearing
15.	02-1679-00	Thrust Race
16.	03-1408-24	Washer (6 req'd)
17.	02-1604-00	Second Gear and Third Pinion Ass'y
18.	02-1603-00	First Gear and Second Pinion Ass'y
19.	13-0617-38	"O" Ring
20.	A22199-000	Gear Case Ass'y

DRIVE UNIT ASSEMBLY
A24095-001

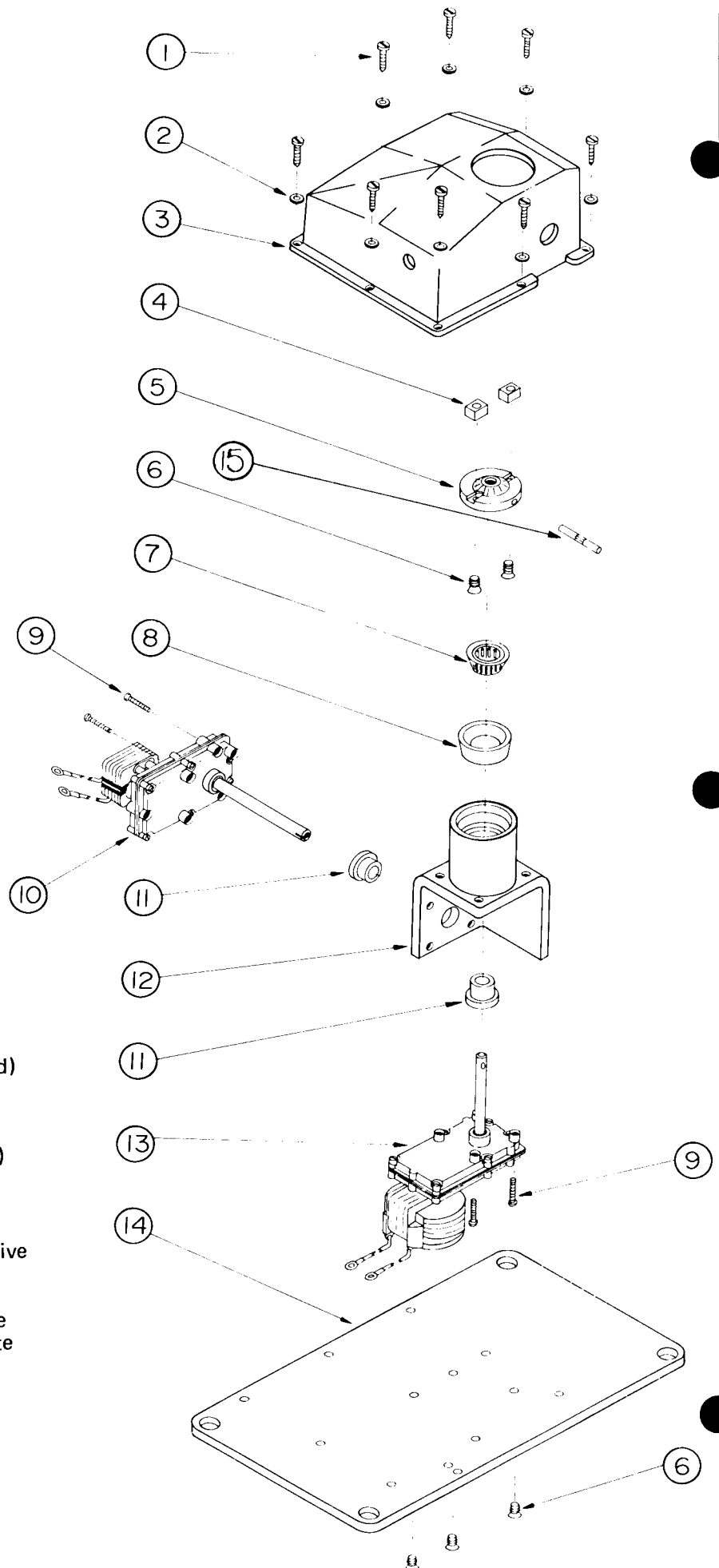

ITEM	PART NO.	DESCRIPTION
1	03-1403-15	Screw (8 req'd)
2	03-1407-02	Washer (8 req'd)
3	02-2049-01	Motor Cover
4	A17482-000	Key
5	A24089-001	Hub Drive
6	03-1418-13	Screw (5 req'd)
7	02-2014-01	Roller Bearing
8		Insert
9	03-1403-36	Screw (8 req'd)
10	12-1851-01	Motor-Auger Drive
11	02-1461-00	Bearing
12	A24087-001	Bin Support
13	12-1850-01	Motor-Bin Drive
14	A23841-001	Motor Mtg. Plate
15	A24094-001	Pin

SPOUT ASSEMBLY
A21655-000

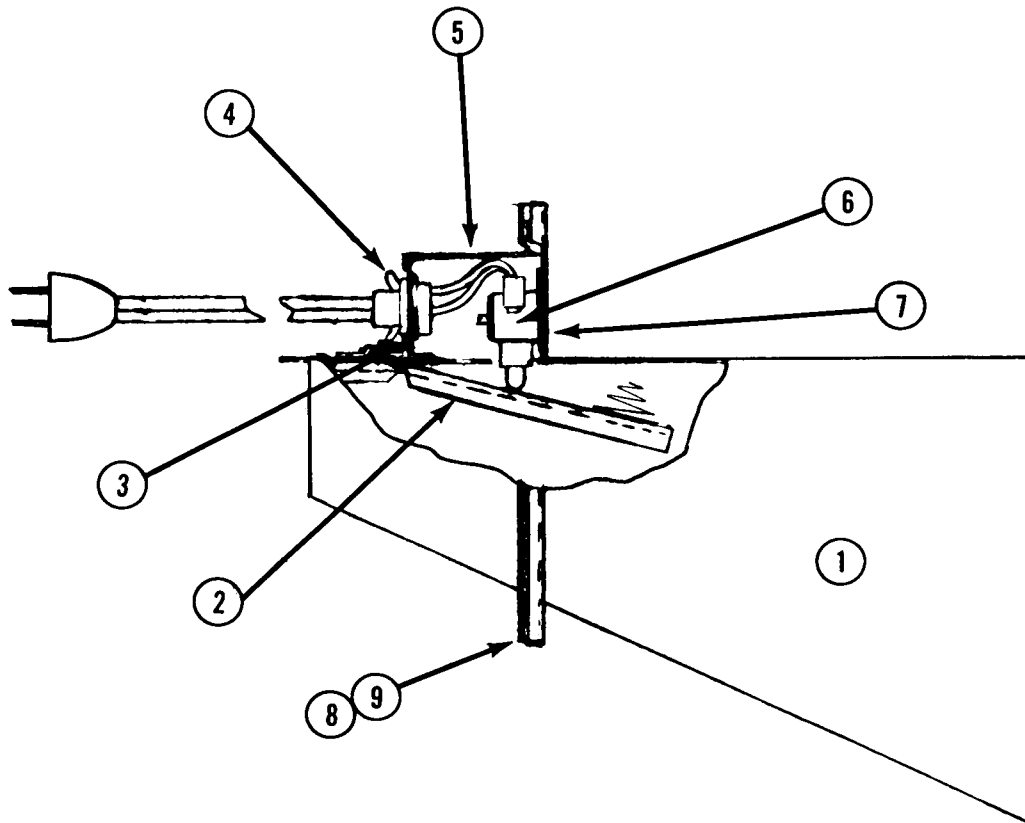

* Not Shown

ITEM NO.	PART NO.	DESCRIPTION
1.	A21656-000	Spout Fab. Ass'y
2.	A16353-000	Spout Pressure Plate
3.	A21654-000	Plate Stop
4.	03-1229-00	Wing Nut
5.	A24453-001	Limit Box Ass'y
6.	12-1018-00	Micro Switch
7.	03-1403-08	Screw
8.	13-0624-02	Gasket
9.	13-0624-01	Gasket
*10.	A14926-000	Locking Pin Spout

SHUTTER ACTUATOR ASSEMBLY
A23738-001

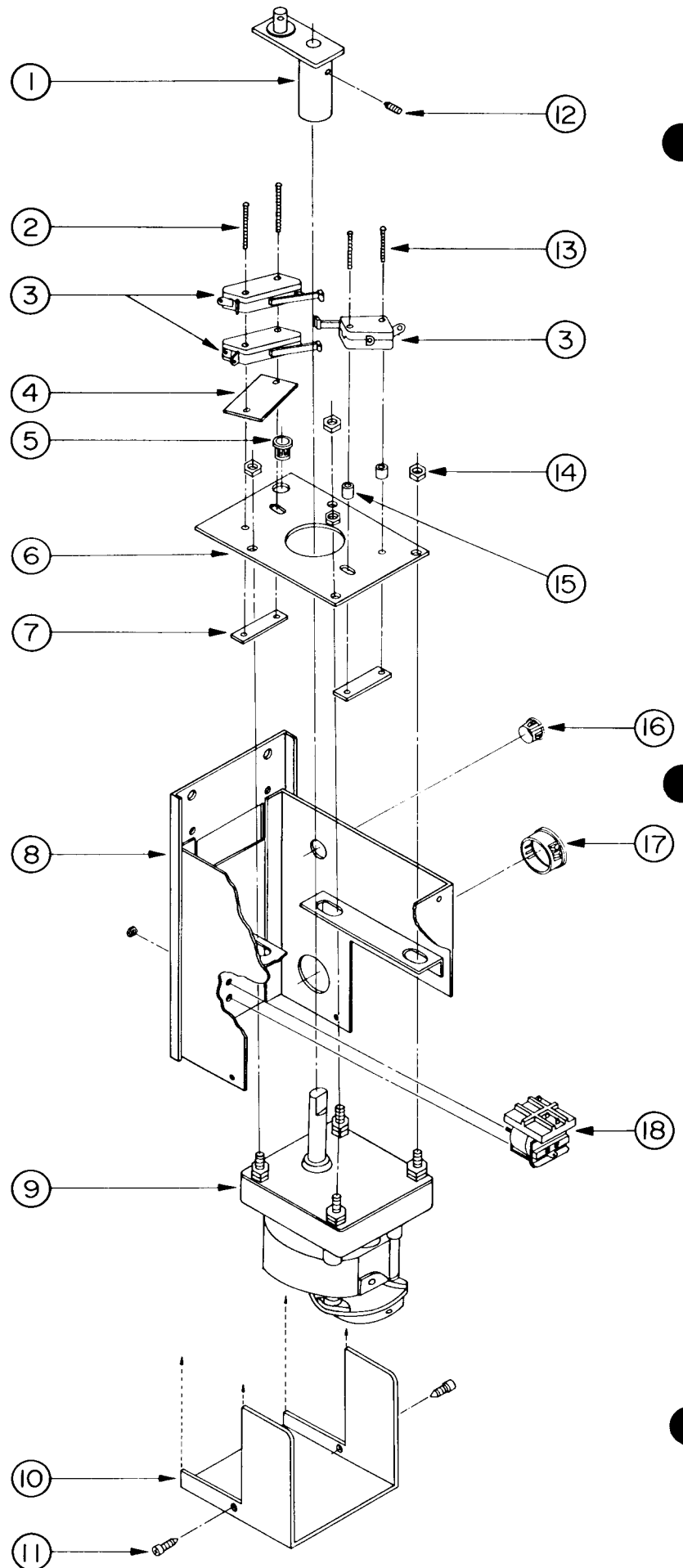

ITEM	PART NO.	DESCRIPTION
1.	A24356-001	Cam Fab. Ass'y
2.	03-1403-63	Screw (2 Req'd.)
3.	12-1614-00	Switch (3 Req'd.)
4.	A21814-000	Fish Paper
5.	12-1213-02	Snap Bushing
6.	A23737-001	Plate, Comp. M. T. G.
7.	A22053-000	Twin Nut (2 Req'd.)
8.	A21220-000	Motor Mounting Fab. Assembly
9.	12-1613-00	Motor, Gear
10.	A21783-000	Shutter Cover
11.	03-1404-05	Screw
12.	03-1451-00	Set Screw
13.	03-1403-62	Screw (2 Req'd.)
14.	03-1406-05	Nut (4 Req'd.)
15.	02-1820-00	Spacer (2 Req'd.)
16.	12-1213-04	Snap Bushing
17.	12-1213-09	Snap Bushing
18.	12-1467-00	Relay

SHUTTER ACTUATOR
ROD ASSEMBLY

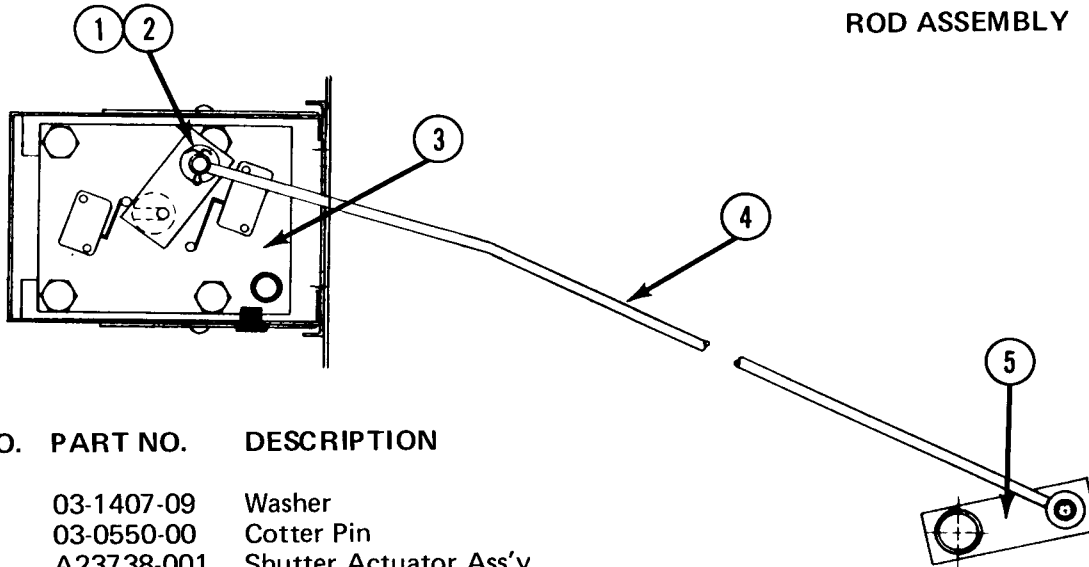

ITEM NO.	PART NO.	DESCRIPTION
1.	03-1407-09	Washer
2.	03-0550-00	Cotter Pin
3.	A23738-001	Shutter Actuator Ass'y (See exploded view, page 27)
4.	A23692-001	Rod, Actuator
5.	A23740-001	Arm, Actuator
*	A25180-001	Ice Shutter Plate
*	A16835-000	Bearing Nut, Ice Shut Off
*	A16857-000	Pin, Ice Shut Off
*	03-1539-01	E-Ring, Ice Shut Off

* Part Not Shown

BIN FULL
SWITCH ASSEMBLY

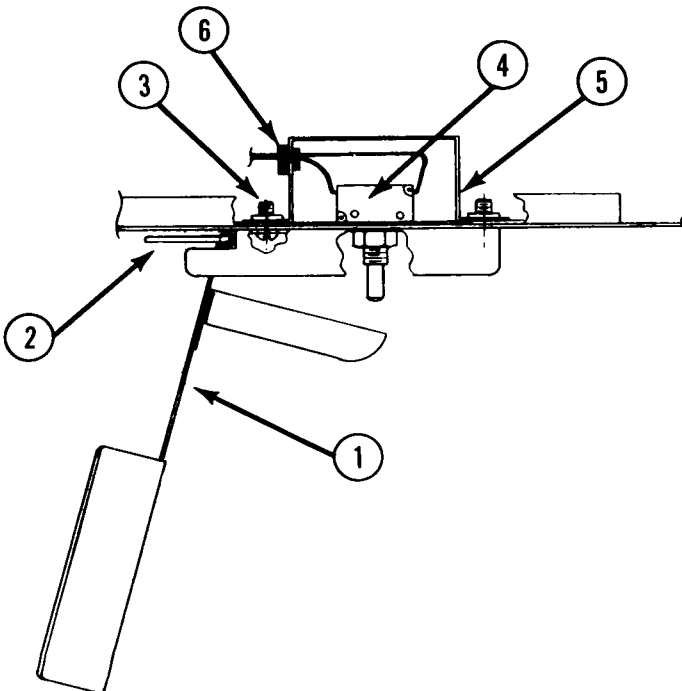

ITEM NO.	PART NO.	DESCRIPTION
1.	A16883-000	Bottom Hinge Ass'y
2.	A16885-000	Pin, Hinge
3.	03-1403-27	Screw
4.	12-1018-01	Switch
5.	A16880-000	Cover Ass'y
6.	12-0629-03	Snap Bushing

ICE DISCHARGE SPOUT ASSEMBLY

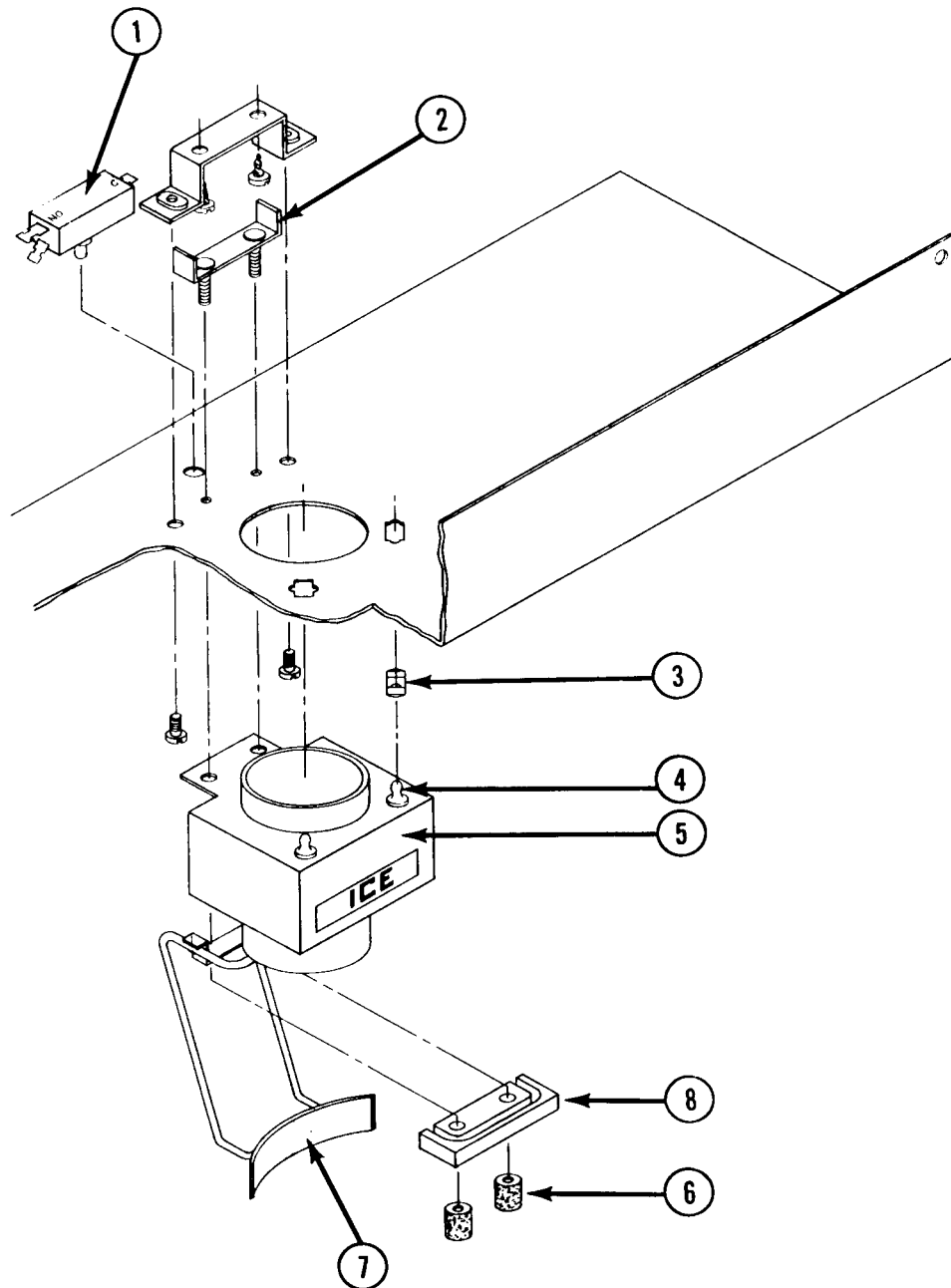

ITEM NO.	PART NO.	DESCRIPTION
1.	12-1570-00	Micro Switch
2.	A24084-001	Bracket Adapter
3.	02-0836-00	Catch, Cabinet
4.	15-0411-00	Strike
5.	A23844-001	Spout Cover
6.	A22031-000	Thumb Nut
7.	02-2090-01	Actuator Arm
8.	A22032-000	Adapter

FD7 RESERVOIR ASSEMBLY

A23532-001 Complete (less cover)

ITEM NO.	PART NO.	DESCRIPTION
1.	A16012-000	Reservoir Cover
2.	02-1259-00	Valve Pin
3.	02-1320-00	Deflector
4.	S08779-000	Inlet Valve
5.	03-1001-00	Rivet
6.	A05777-000	Valve Seat Holder
7.	S06947-000	Valve Seat
8.	03-1394-00	Nut
9.	A12869-000	Bracket
10.	S06715-000	Stand Pipe
11.	S08138-000	Inlet Valve Ass'y
12.	A23533-001	Reservoir Body
13.	A08055-000	Bracket Nut
14.	A12067-000	Float and Arm Ass'y
15.	A18418-001	Water Deflector

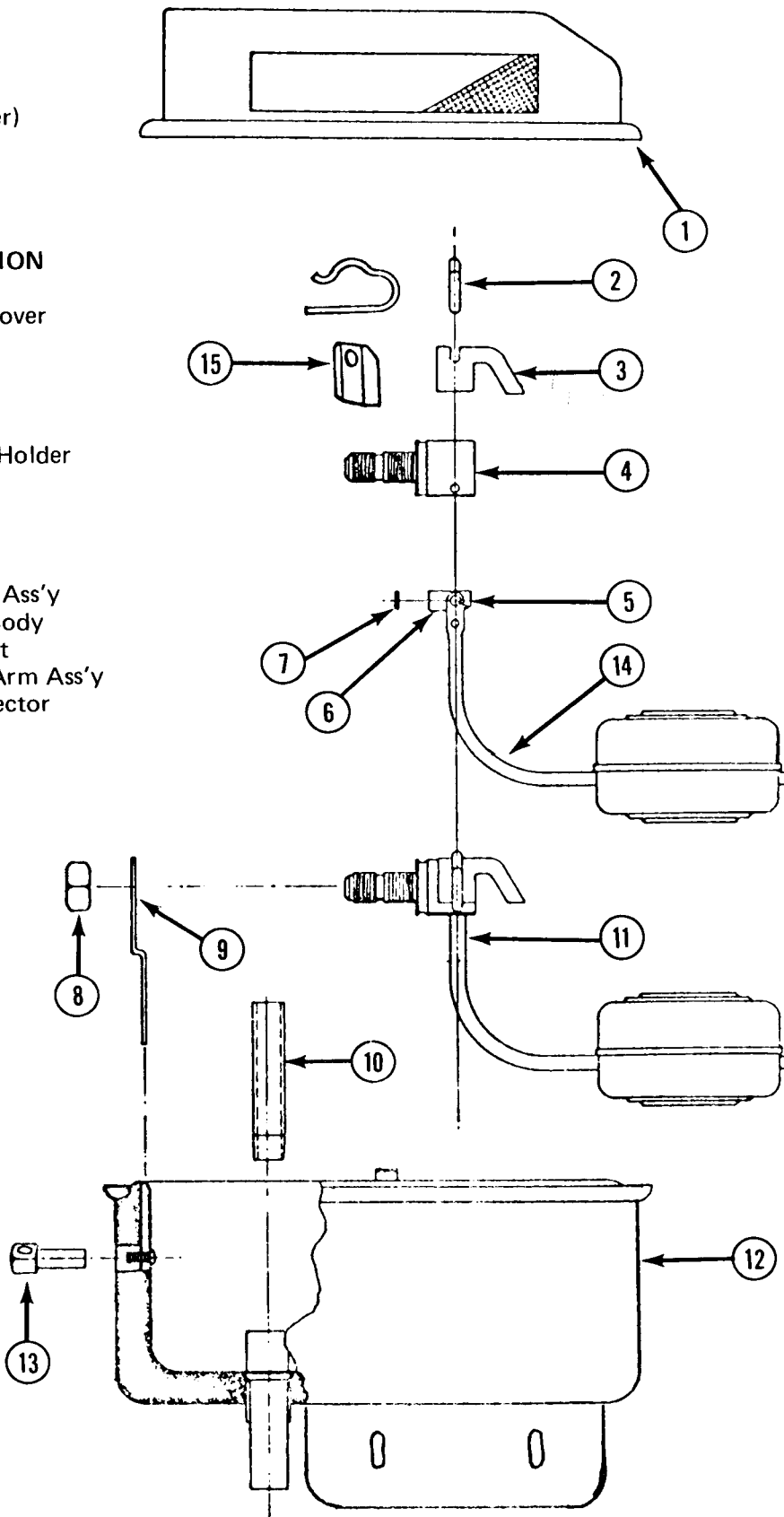

CONTROL BOX

Air Cooled

A23697-001

ITEM NO.	PART NO.	DESCRIPTION
1.	A23696-001	Control Box Fab Ass'y
2.	12-1809-00	Transformer
3.	03-1403-04	Screw
4.	12-0419-01	Relay
5.	03-1403-20	Screw
6.	11-0358-00	Pressure Control
7.	03-1403-02	Screw
8.	13-0557-00	Grommet
9.	12-0994-00	Socket
10.	03-1406-01	Nut
11.	12-1213-12	Snap Bushing
12.	03-1403-21	Screw
13.	12-1861-01	Terminal Block
14.	12-0537-00	Toggle Switch
15.	03-1403-17	Screw
16.	A24272-001	Relay Sub Ass'y
17.	12-1213-10	Snap Bushing
18.	03-1417-03	Washer
19.	12-1860-01	Terminal Block

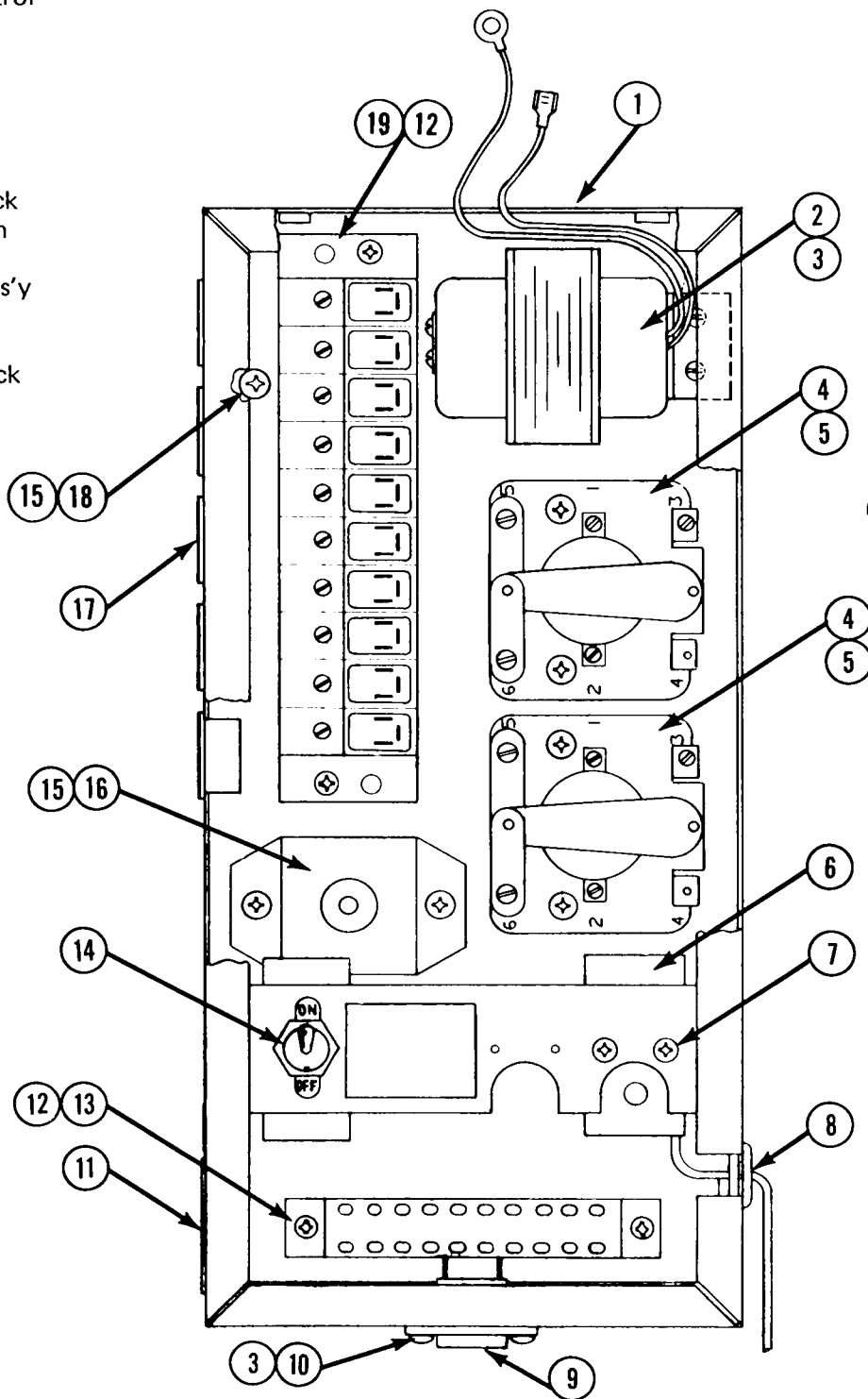

CONTROL BOX
Water Cooled
A24195-001

ITEM NO.	PART NO.	DESCRIPTION
1.	A23696-001	Control Box Fab Ass'y
2.	12-1809-00	Transformer
3.	03-1403-04	Screw
4.	12-0419-01	Relay
5.	03-1403-20	Screw
6.	11-0358-00	Pressure Control
7.	03-1403-02	Screw
8.	11-0357-02	Pressure Control
9.	13-0557-00	Grommet
10.	12-0994-00	Socket
11.	03-1406-01	Nut
12.	12-1213-12	Snap Bushing
13.	03-1403-21	Screw
14.	12-1861-01	Terminal Block
15.	12-0537-00	Toggle Switch
16.	03-1403-17	Screw
17.	A24272-001	Relay Sub Ass'y
18.	12-1213-10	Snap Bushing
19.	03-1417-03	Washer
20.	12-1860-01	Terminal Block

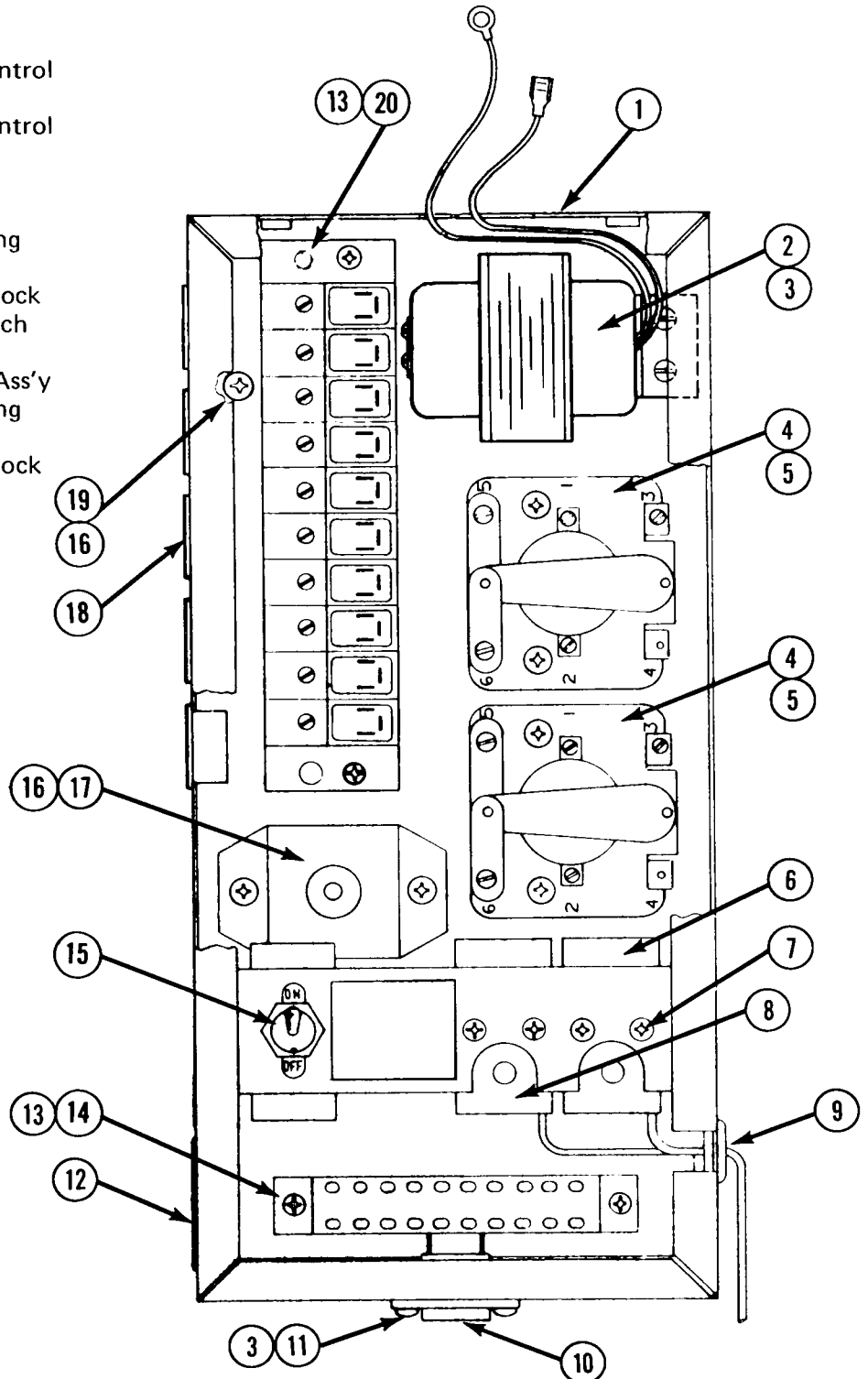

CABINET PARTS

ITEM NO.	PART NO.	DESCRIPTION
1.	03-1404-09	Screw
2.	A24243-001	Hole Plate
3.	03-1403-47	Screw
4.	03-1417-09	Washer
5.	03-1403-17	Screw
6.	02-1472-04	Plug Button
7.	03-1418-07	Screw
8.	03-1422-06	Speed Nut
9.	03-1418-11	Screw
10.	03-1403-19	Screw
11.	A23572-001	Back Panel, Painted
12.	A23574-001	Top Panel, Painted
13.	A24853-001	Side Panel, Left, Painted
14.	A24837-001	Side Panel, Lower Left, Painted
15.	A23702-001	Front Panel Ass'y, Painted
16.	A23523-001	Door Ass'y, Painted
17.	A23575-001	Control Panel, Painted
18.	A24852-001	Side Panel, Right, Painted
19.	A24837-002	Side Panel, Lower Right, Painted
20.	A23572-002	Back Panel, SS
21.	A23574-002	Top Panel, SS
22.	A24853-002	Side Panel, Left, SS
23.	A24837-003	Side Panel, Lower Left, SS
24.	A23702-002	Front Panel Ass'y, SS
25.	A23523-002	Door Ass'y, SS
26.	A23575-002	Control Panel, SS
27.	A24852-002	Side Panel, Right, SS
28.	A24837-004	Side Panel, Lower Right, SS
29.	A23857-001	Backsplash Assy
30.	02-2021-01	Grill
31.	A24207-001	Sink Fab Ass'y
32.	02-0932-00	Clamp
33.	13-0617-11	"O" Ring
34.	A20250-003	Tube
35.	02-1741-00	Drain Top
36.	02-1742-00	Drain Bottom
37.	A23704-001	Sink Support
38.	A23704-002	Sink Support

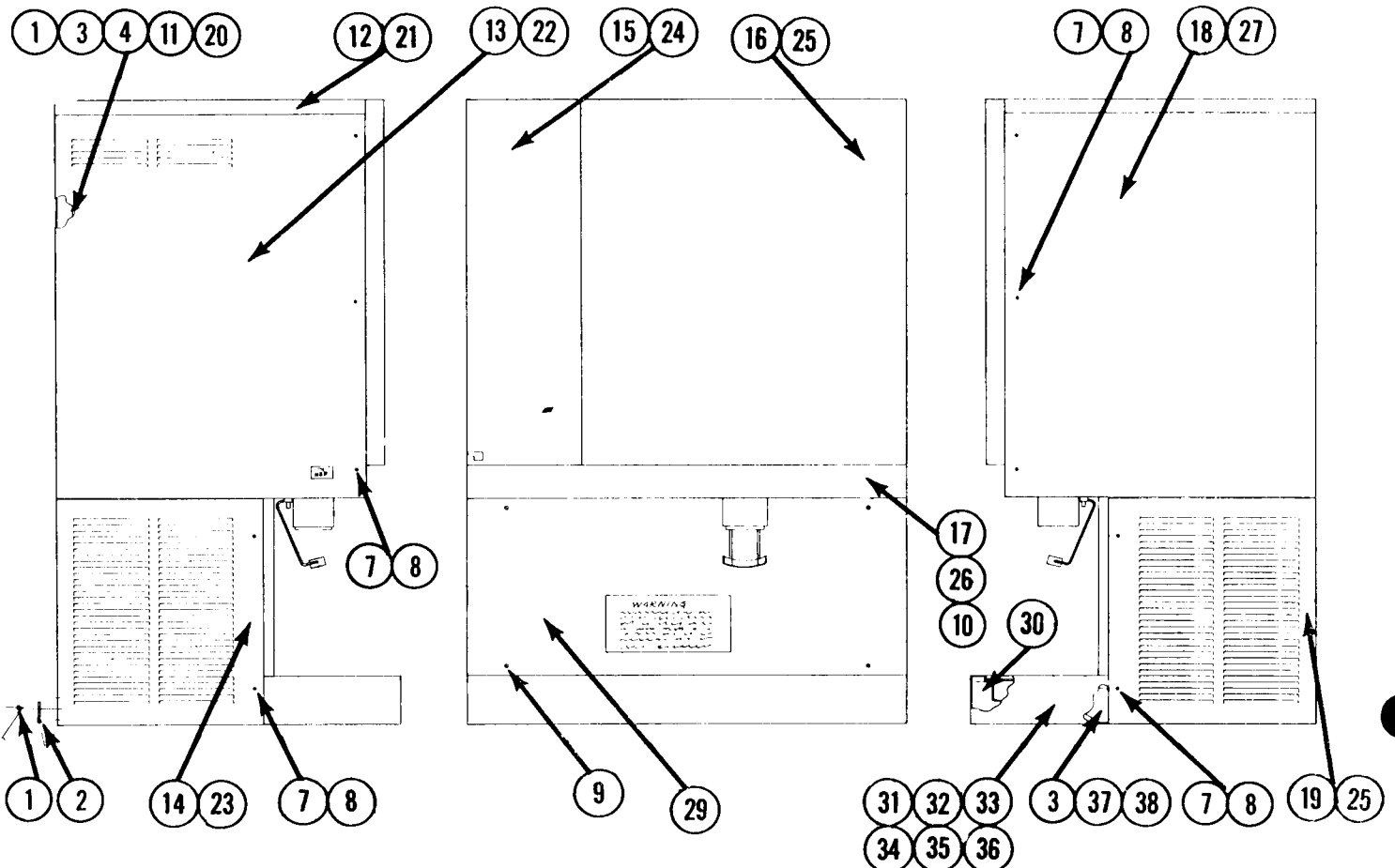

If the user requires frequent access to the water and portion controls, the switches can be moved to the panel below the door. A copy of the instructions listed below is packed with each machine along with new decals.

OPTIONAL MOUNTING FOR WATER AND ICE SWITCH

1. Remove left side panel. Remove switches from switch mount panel by loosening lock-nuts.
2. Remove (2) screws from switch mount panel and lift panel from unit.
3. It is necessary to drill (3) holes in control panel to remount switches. To do this, you will need a 5/32 dia. drill, 3/8 dia. drill, and 15/32 dia. drill.
4. Hold switch mount panel in original position except with bottom portion, with (3) holes, on outside of control panel. Either mark hole locations and remove panel, or drill holes using panel as template.
5. Replace switch mount to original position. Place ice and water decals in position and install switches. Replace left side panel and unit is ready for operation.

17-1173-01

SPECIAL KITS AND ACCESSORIES AVAILABLE FOR THE FD7

Back Splash Extention Kit, KSP2 — to be used when unit is mounted over a sink. The standard sink and back splash panel are removed and the kit installed.

Glass Filler Kit, KGF1 — to be installed when two discharge spouts are required. One used for water only and the other for ice only.

Machine stand, DMS30E or DMS30SS — to be used when the FD7 is mounted on the floor.

Wall Mounting Kit, KWB2 — This is the only approved method for mounting the FD7 on a wall. All other methods may be dangerous because of the weight of the machine.