

To the Owner or User:

The Service Manual you are reading is intended to provide you, and the maintenance or service technician, with the information needed to install, start up, clean, maintain, and service the ice system.

Refer to this table of contents to locate the information you need.

TABLE OF CONTENTS

GENERAL INFORMATION & INSTALLATION	
For the Installer	2
For the Electrician	10
For the Plumber	13
OPERATION	
Start-Up	15
Operation	18
Operation - Electrical Sequence	23
MAINTENANCE & CLEANING INSTRUCTIONS	
Icemaker	27
Ice Storage Bin	27
Remote Condenser	29
COMPONENT DESCRIPTION	31
SERVICE DIAGNOSIS	36
REMOVAL AND REPLACEMENT PROCEDURES	
Water Pump	40
Reservoir	40
Distributors/Water Manifolds	40
Inlet Water Valve	40
Cube Size Control	41
Timer	41
Bin Thermostat	41
Pressure Controls	41
Compressor	42
Hot Gas Valve or Liquid Line Valve	42
Thermostatic Expansion Valve	42
Head Pressure Control Valve	42
Evaporator Plate Assembly	43

LIST OF ILLUSTRATIONS

Specifications	2
Stacking Instructions	5
Bin Control Installation	6
Component Location	7
Remote Condenser Installation	8
Coupling Instructions	9
Electrical Connections	10
Water & Drain Connections	13
Final Checklist	14
Timer Cam Positions	15
Ice Cube Size & Shape	16
Cube Size Adjustment	17
Freezing Cycle	18
Harvest Cycle	19
Pump Down	20
Water Flow Schematic	22
Maintenance & Cleaning Instructions	29
Component Description	30
Removal and Replacement	39
Removal and Replacement - Control Box	41
Removal and Replacement - Evaporator Assembly	43
PARTS LIST AND WIRING DIAGRAM	1
(Printed in Yellow)	
PARTS LIST:	
Component Location	2
Exterior Cabinet	3
Control Box	4
Water System	5
Refrigeration Assembly	6
Remote Condenser	8
Pre-Charged Tubing Kit	8
KCMR230	8
BH800	9
WIRING DIAGRAM:	
CM855RE-32A	10

**THIS PAGE
INTENTIONALLY
LEFT BLANK**

CM855R FOR THE INSTALLER

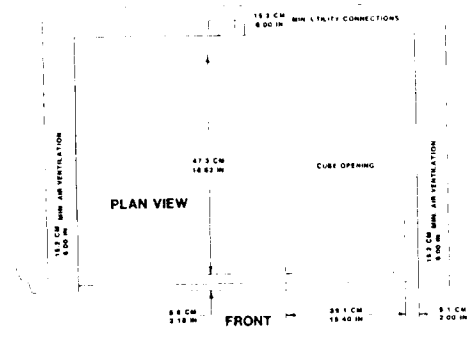

CM855R CABINET SIZE AND UTILITY CONNECTIONS

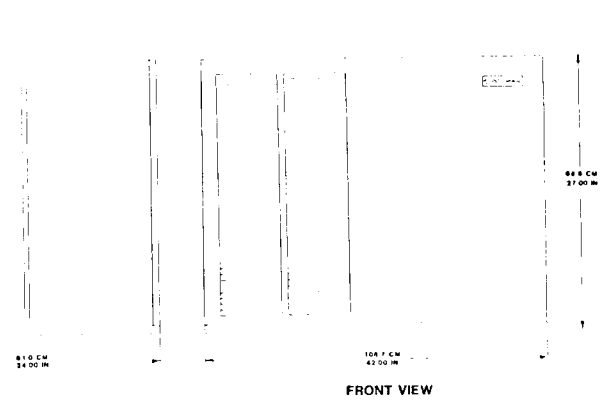
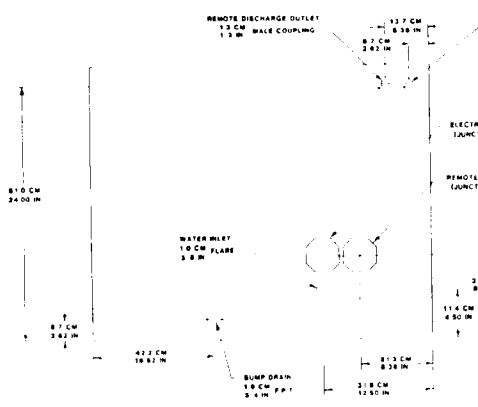

REMOTE CONDENSER

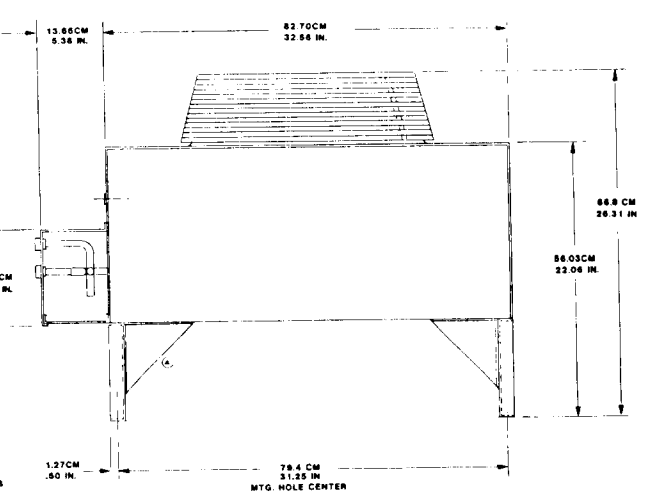
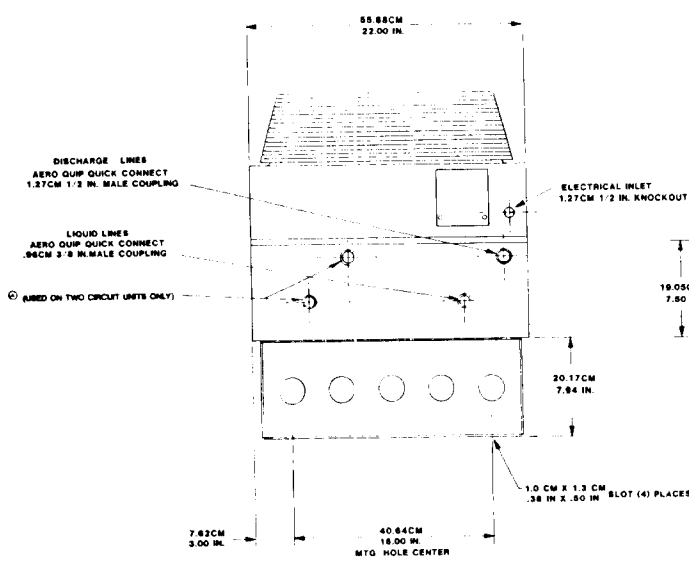
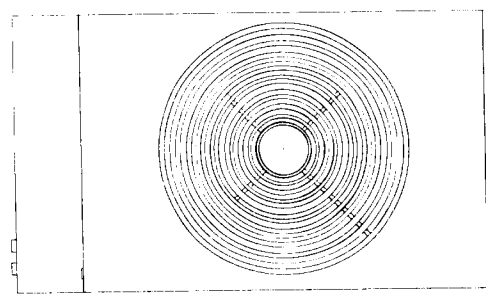

CM855R FOR THE INSTALLER

EQUIPMENT LIST:

All of the following components must be available before assembly.

Icemaker: CM855RE-32 or CM855RE-3

Ice Storage Bin: BH800E or BH800S or acceptable substitute. Legs kits included with storage bin.

Pre-charged refrigerant lines (R-502)

RT625 = 25 feet

RT640 = 40 feet

Remote Condenser, R502



RC1051-32A single pass

RC1052-32A double pass

If two CM855RE's are to be installed on one RC1052-32A condenser, a fan relay kit, KCMR230 must be used to operate the condenser fan.

NAMEPLATE

MODEL NUMBER						
SERIAL NUMBER						
A C SUPPLY VOLTAGE						
MINIMUM CIRCUIT AMPACITY				WIRES		
MAXIMUM FUSE SIZE *				HERTZ		
HEATER WATTS				PHASE		
REFRIGERANT		CHARGE		OZ.		
MOTORS	VOLTS	RLA	FLA	WHP.	LR	RA
COMPRESSOR						
FAN						
DRIVE						
OTHER						
DESIGN PRESSURE		LOW		HIGH		
* OR HACR TYPE CIRCUIT BREAKER						

SCOTSMAN.

Scotsman Ice Systems are designed and manufactured with the highest regard for safety and performance. They meet or exceed the standards of U.L., N.S.F. and C.S.A.

Scotsman assumes no liability or responsibility of any kind for products manufactured by Scotsman that have been altered in any way.

Scotsman reserves the right to make changes and/or improvements at any time.

Specifications and designs are subject to change without notice.

SPECIFICATIONS: Icemaker

Model Number	(Height w/o bin) Dimensions H" x W" D"	Ice Type	Basic Electrical	Compressor HP	Minimum Circuit Ampacity+	Maximum Fuse Size
CM855RE-32B	27 x 42 x 24	Contour Cube	208-230/60/1	1.75	16.5	30
CM855RE-3B	same	Same	208-230/60/3	same	13.5	20

The standard finish is enamel sandalwood. The optional kit to convert the CM855 to stainless steel is: SPKCM1000.

SPECIFICATIONS: Remote Condenser

Model Number	Dimensions H" x W" x D"	Use With	Basic Electrical	Minimum Circuit Ampacity*
RC1051-32A	27 ³ / ₁₆ x 22 x 37 ¹ / ₂	1-CM855RE	208-230/60/1	2
RC1052-32A	same	1 or 2 CM855RE	same	same

The finish of the condenser is galvanized.

+ Use this value to determine wire size as per national electric code.

* The ampacity for the remote condenser is included in the icemaker's ampacity. Use this figure to determine wire size between the icemaker and the condenser fan motor, per the National Electric Code.

CM855R FOR THE INSTALLER

SPECIFICATIONS - Storage Bin

Model Number	(Height - w/o Legs) Dimensions H" x W" x D"	Use With	Storage Capacity	Finish	Ship. Wt.
BH800E	44" x 42" x 31.5"	CM1000	800	Enamel Sandalwood	177 lbs.
BH800S	44" x 42" x 31.5"	CM1000*	800	Stainless Steel	186 lbs.

OPERATING LIMITATIONS

	MINIMUM	MAXIMUM
TEMPERATURE*		
Air Temperature	50°F (10.0°C)	100°F (38°C)
Water Temperatures	40°F (4.4°C)	100°F (38°C)
Water Pressure	20 lbs. gauge	100 lbs. gauge
Electrical Voltage Variations		
Voltage rating specified on nameplate	-5%	+ 10%

* This does not include the remote condenser. The remote condenser can operate between -20°F and 120°F.

NOTICE: Extended periods of operation exceeding the above limitations constitute misuse under the terms of the manufacturer's limited warranty, and can result in a loss of warranty.

Nameplate location: see illustration page 7.

BH800 BIN

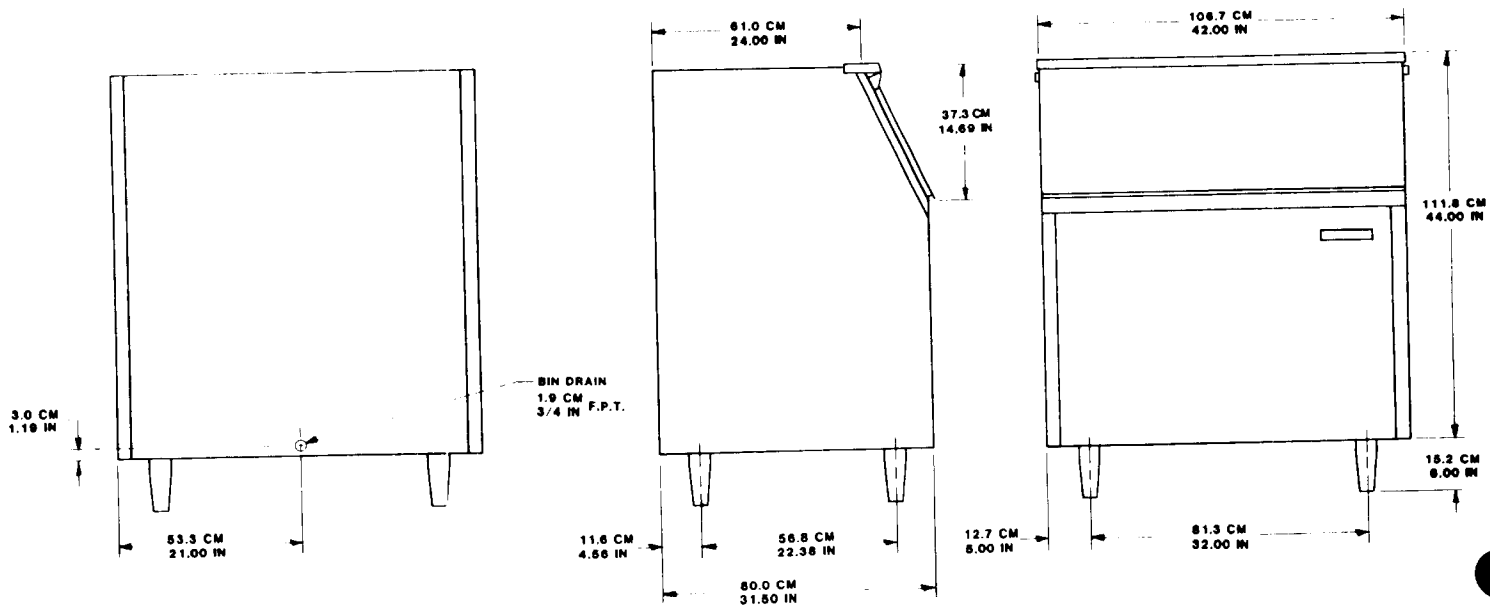

CM855R FOR THE INSTALLER

LOCATION

The first step in installing this equipment is to select the location. The purchaser of the unit will have a desired spot for it, so go over the location with the purchaser to insure that it is

- indoors - icemaker and bin.
- that the air and water temperatures do not exceed the design limitations for the equipment.
- that the necessary utilities are available
 - the correct voltage electrical power, the correct size water and drain lines.
- that there is some space around the unit available for servicing it and the utilities that are connected to it.
- that the distance between the icemaker and the remote condenser is less than the length of pre charged tubing on hand.



FROM HARDWARE BAG

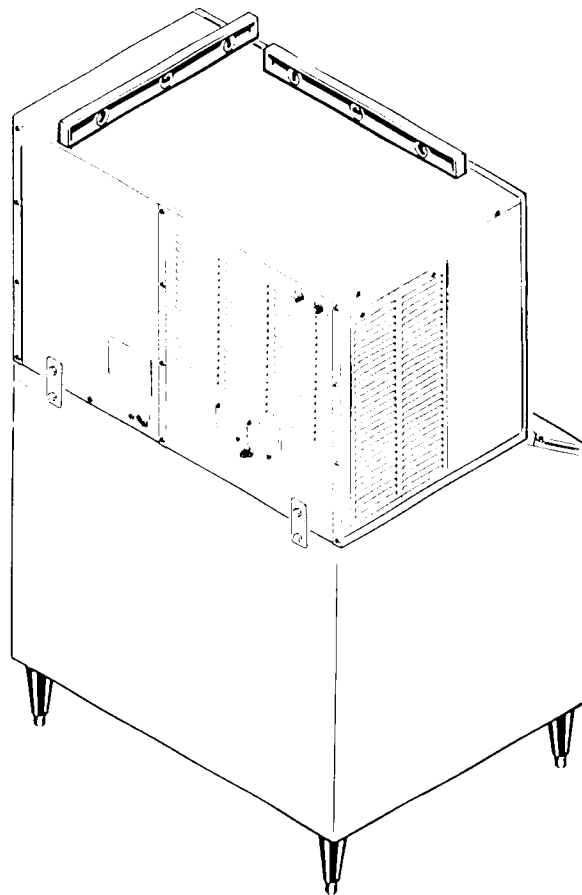

STORAGE BIN

Carefully lay the bin on its back, and install the legs (if used) into the threaded holes in the bottom of the bin. Stand the bin upright, and examine the bin top edge gasket for tears and gaps. Small gaps can be filled using food grade silicone sealant, just prior to installing the icemaker on the bin.

PLACE ICEMAKER ONTO THE BIN

The use of a mechanical lift is recommended for lifting the uncrated icemaker onto the bin. Place the unit directly onto the bin, align the panels so that the unit is even with the back, left and right sides of the bin. Locate hardware package, take out two metal straps, and 2 mounting bolts. Remove shipping channel from left back panel. Use the two cap screws from it and the two screws from the hardware package to secure the icemaker to the bin. See illustration.

STACKING INSTRUCTIONS

If two icemakers are placed on one bin, the stacking of the machine requires the following:

- Remove the top panel from the lower unit.
- Place a bead of food grade silastic rubber on the top edge of the lower unit freezing compartment.
- Using a mechanical lift, lift the top machine and place it on top of the bottom unit. Align the top unit to the bottom one.
- Using the straps and bolts from the top machine's hardware package, secure the top unit to the bottom one (see illustration).
- Locate and discard the upper unit bin control bracket.
- Route upper unit bin control capillary tube through the hole in the base of the upper unit, through the lower unit, and install it inside the bin control bracket **with** the lower unit bin control capillary tube.

CM855R FOR THE INSTALLER

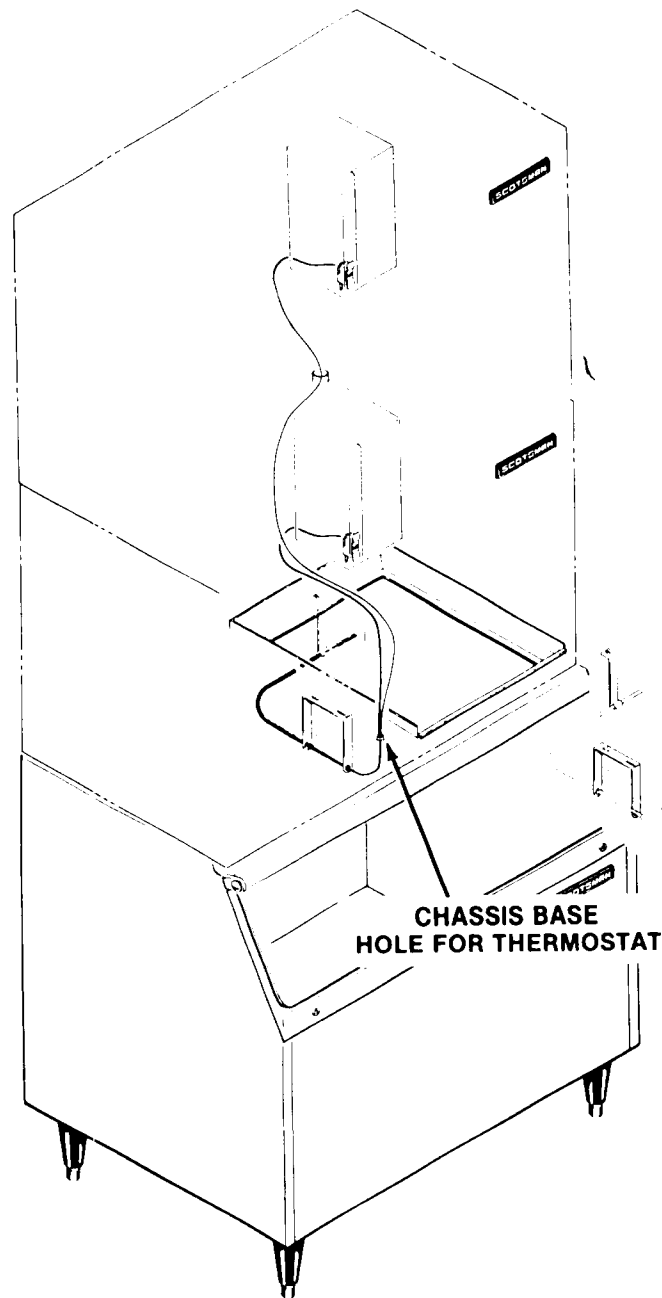

BIN CONTROL

The bin control bracket is packed for shipping in a cardboard retainer, located in front of the freezing compartment, behind the front panel. It is to be mounted onto the bottom of the icemaker **after** the unit has been installed on the bin. Discard rubber tip.

Using 3 thumbscrews from the hardware package, mount the bracket to the machine:

- A. First install one screw in the hole provided at the back of the unit, and then slip the bracket hanger over the head of the screw (see illustration).
- B. Use the two remaining screws to secure the bracket on the left side of the freezing compartment.
- C. Uncoil and install the bin thermostat capillary tube into the bracket, stopping at the end of the tube.

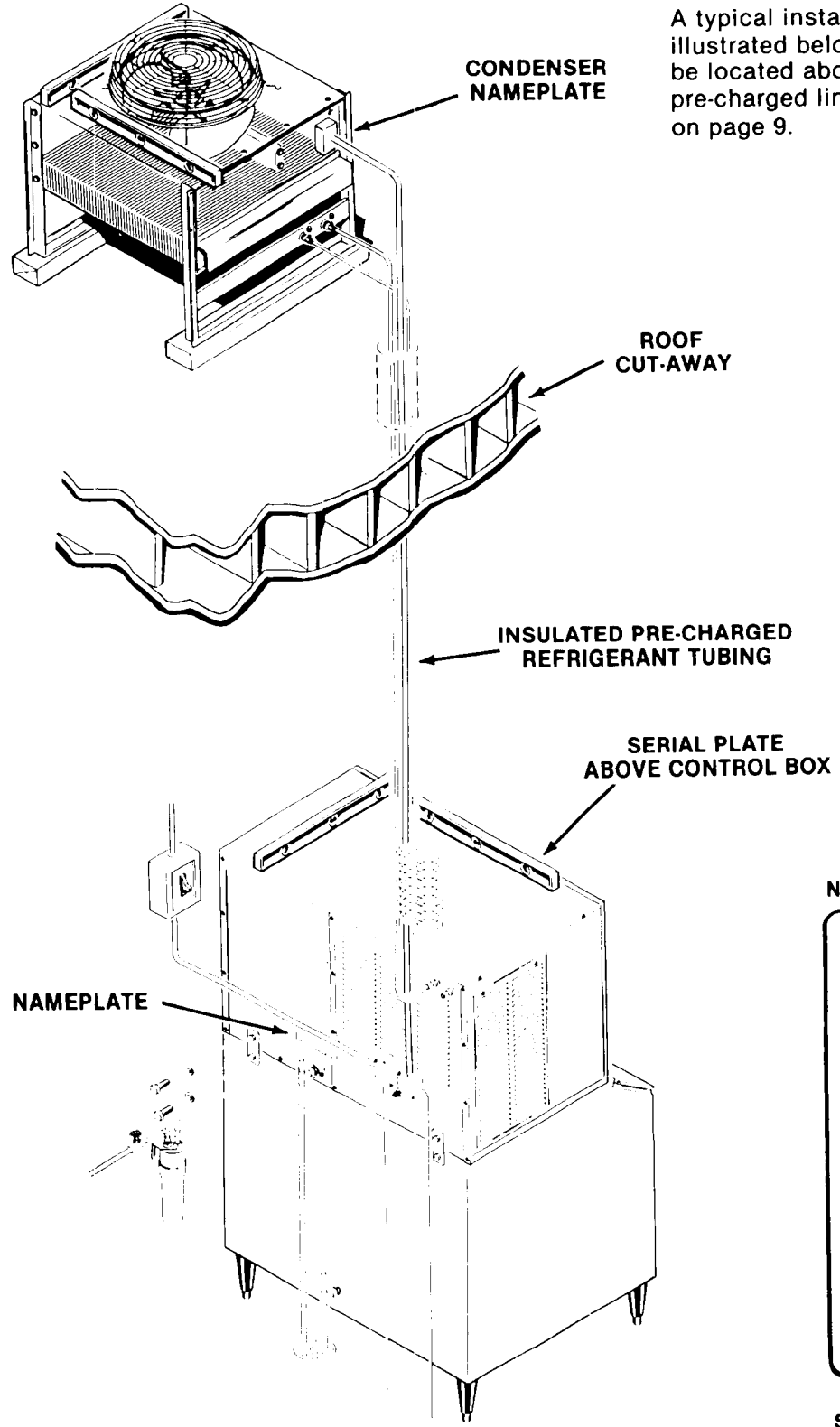

CM855R FOR THE INSTALLER

A typical installation should generally appear as illustrated below. The remote condenser must be located above the icemaker and the pre-charged lines installed per instructions on page 9.



NAME PLATE

MODEL NUMBER			
SERIAL NUMBER			
A.C. SUPPLY VOLTAGE		WIRES	
MINIMUM CIRCUIT AMPACITY		HERTZ	
MAXIMUM FUSE SIZE *		PHASE	
HEATER WATTS			
REFRIGERANT	CHARGE	OZ.	
MOTORS	VOLTS	R.L.A./F.L.A.	W/H.P. L.R.A.
COMPRESSOR			
FAN			
DRIVE			
OTHER			
DESIGN PRESSURE	LOW	HIGH	
* OR HACR TYPE CIRCUIT BREAKER			

SCOTSMAN A HOUSEHOLD INTERNATIONAL COMPANY

ALBERT LEA, MINNESOTA U.S.A.

SERIAL NUMBER PLATE

MODEL NUMBER	
SERIAL NUMBER	
VOLTS/HERTZ/PHASE	
MAXIMUM FUSE SIZE	
REFRIGERANT	CHARGE OZ.

CM855R FOR THE INSTALLER

REMOTE CONDENSER INSTALLATION

Location Considerations:

Limited to a 40-foot length or a 25-foot length of pre-charged refrigerant line from the rear of the icemaker chassis to the remote condenser with consideration for routing. The condenser must be above or level with the highest (if stacked) icemaker.

Best available location, protected from the extremes of dirt, dust, and sun.

Must meet local building code installation requirements. Usually the services of a licensed electrician are required.

Remote Condenser - Roof Attachment.

1. Install and attach the remote condenser to the roof of the building, using the methods and practices of building standards that conforms to and meets the local building code requirements in your area.
2. Have an electrician connect the remote condenser fan motor electrically to the CM855R at the junction box of the remote condenser and junction box of the CM855R.

PRE-CHARGED TUBING KIT ROUTING:

//////////////////// CAUTION //////////////////////

Do not connect pre-charged tubing until all routing and forming of tubing is complete. See Coupling Instructions, Pre-Charged Tubing Kit, page 9, for connecting instructions.

////////////////////////////////////

1. Each set of pre-charged refrigerant lines in the 25-foot length, or 40-foot length kits, consists of a 3/8-inch diameter, self-sealing LIQUID line and a 1/2-inch diameter, self-sealing DISCHARGE line. One coupling on each line is fitted with a charging port, which provides the service man with access for service gauges at the REMOTE CONDENSER location, when necessary.

NOTE

The openings in the building ceiling or wall, listed in the next step, are minimum sizes recommended, through which the pre-charged refrigerant lines may pass; and are to be considered only if they conform to and meet the local building code requirements in your area.

2. Minimum recommended sizes for openings required in a ceiling or wall for the pre-charged refrigerant lines to pass, is 1-3/4 inch diameter.

//////////////////// CAUTION //////////////////////
DO NOT KINK OR CRIMP REFRIGERANT LINES.
////////////////////////////////////

3. Route both refrigerant lines through the roof opening.
Follow straight line routing, when possible.
Retain excess pre-charged refrigerant line **INSIDE** the building.
4. **SPIRAL** the excess footage of the pre-charged refrigerant lines, in the best selected **INSIDE** location. See Pre-Charged Refrigerant Line Routing illustration for recommended methods of spiralling the excess refrigerant lines.

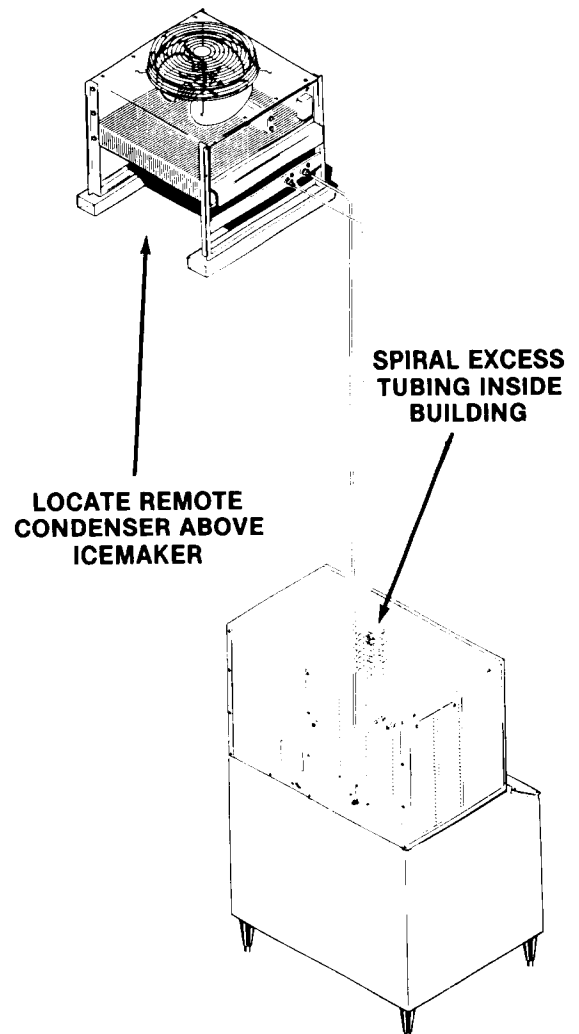

CM855R FOR THE INSTALLER

COUPLING INSTRUCTIONS, PRE-CHARGED TUBING KIT

//////////////////// CAUTION //////////////////////

The couplings on the sets of pre-charged refrigerant lines, the refrigerant fittings on the Remote Condenser, and the rear of the Icemaker Chassis are SELF-SEALING and should be connected as follows:

////////////////////

1. Remove protector caps and plugs and if necessary, carefully wipe coupling seats and threaded surfaces with a clean cloth to prevent the inclusion of dirt or any foreign material in the system.
2. LUBRICATE male half diaphragm and synthetic rubber seal with refrigerant oil. Thread coupling halves together by hand to insure proper mating of threads. Use proper size wrenches (on coupling body hex and on union nut) and tighten until coupling bodies "bottom" or a definite resistance is felt.
3. Using a marker or ink pen, mark a line lengthwise from the coupling union nut to the bulkhead. Then tighten an additional 1/4 turn; the misalignment of the line will show the amount the coupling has been tightened. This final 1/4 turn is necessary to insure the formation of leakproof joint.

ALWAYS USE TWO WRENCHES WHEN TIGHTENING THESE FITTINGS, ONE AS BACKUP WRENCH TO PREVENT TWISTING OF TUBING AND POSSIBLE KINKING OR LINE RUPTURE.

BE SURE to connect the ends of the pre-charged refrigerant lines, that have the charging port fittings, TO THE REMOTE CONDENSER FITTINGS. This gives the serviceman access for service gauges at the REMOTE CONDENSER location, when necessary.

4. Connect the 3/8-inch diameter refrigerant line coupling, with the SERVICE PORT fitting, to the remote condenser refrigerant fitting labeled: LIQUID LINE as detailed in Coupling Instructions.
5. Connect the 1/2-inch diameter refrigerant line coupling, with the CHARGING PORT fitting, to the Remote Condenser refrigerant fitting labeled: DISCHARGE LINE. Tighten as detailed in the Coupling Instructions.

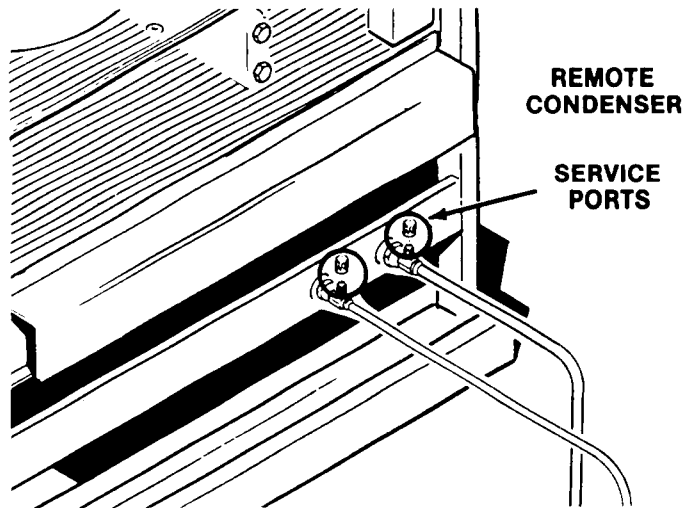

6. Connect the 3/8-inch diameter refrigerant line coupling, to the refrigerant fitting on the upper right rear of the icemaker chassis labeled: LIQUID LINE. Tighten as detailed in Coupling Instructions.
7. Connect the 1/2-inch diameter refrigerant line coupling, to the refrigerant fitting on the upper right rear of the icemaker Chassis labeled: DISCHARGE LINE. Tighten as detailed in step 4.

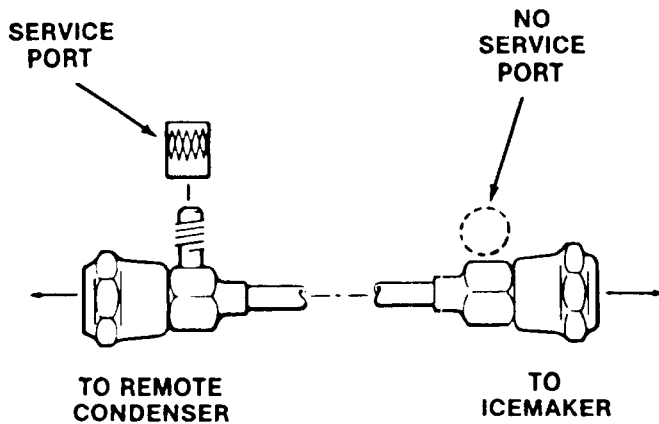

Pre-Charged Refrigerant Line Connections

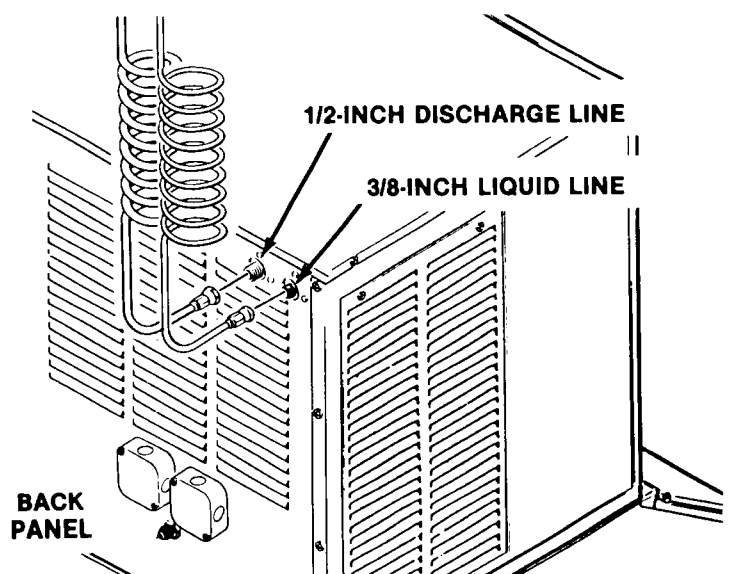

CM855R FOR THE ELECTRICIAN

CONFORM TO ALL APPLICABLE CODES

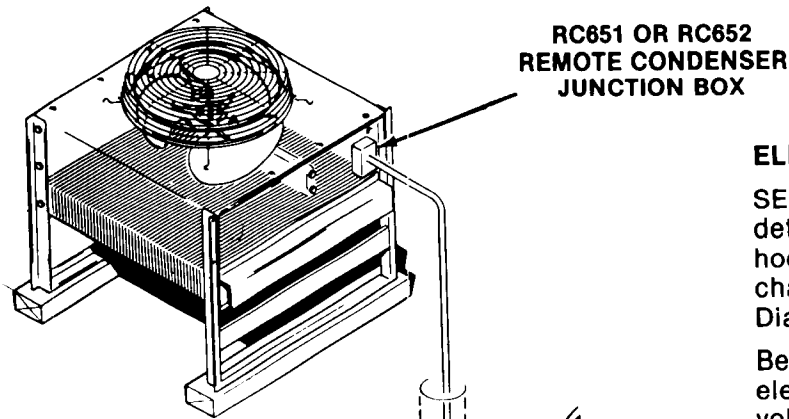

ELECTRICAL CONNECTIONS

SEE NAMEPLATE for current requirements to determine wire size to be used for electrical hookup. The cuber requires a solid chassis-to-chassis earth ground wire. See Wiring Diagram.

Be certain the cuber is connected to its own electrical circuit and individually fused. Running voltage must not be less than 95% of the lower nameplate voltage, or more than 110% of the higher nameplate voltage. Low voltages can cause erratic operation and may be responsible for serious damage to the icemaker.

Electrical connections are made at the rear of the icemaker, inside the junction box.

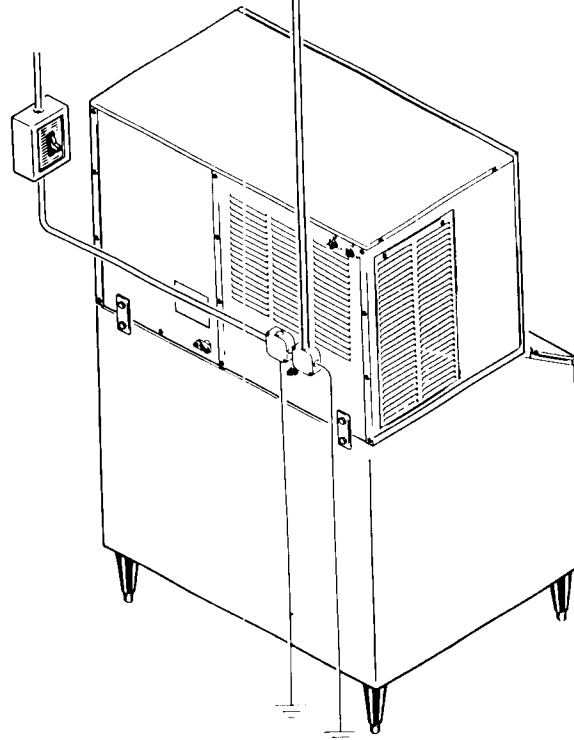
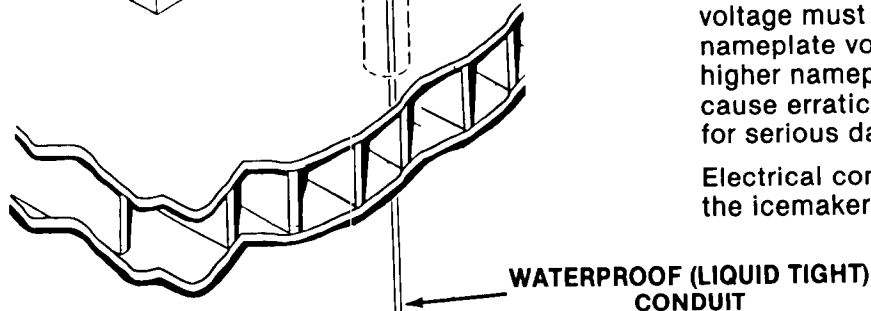

The remote condenser must be wired to the CM855R icemaker in accordance with local and national electrical codes with a minimum of 18 Awg wire with a ground bonding wire connected to the ground screws provided in both the condenser and machine field wiring boxes. All outdoor wiring must be in rainproof conduit.

All external wiring should conform to the national, state and local electrical code requirements. Usually an electrical permit and services of a licensed electrician will be required.

Electrically the remote condenser fan motor is connected to the CM855R at the contactor terminals for the compressor and the fan motor operates whenever the compressor operates.

CM855R FOR THE ELECTRICIAN

FAN RELAY KIT

Installation instructions for the KCMR230 Kit when using (2) CM855R Ice makers and the RC652-32B Model Condenser.

SEE NAMEPLATE for current requirements to determine wire size to be used for electrical hookup. Refer to wiring diagram.

All external wiring should conform to the national, state and local electrical code requirements. Usually an electrical permit and services of a licensed electrician will be required.

FOR CONNECTION OF TWO ICEMAKERS:

Refer to appropriate wiring diagrams and connect each icemaker to the KCMR230 terminal strip as follows:

1. Attach the KCMR230 to a permanent location, convenient for each icemaker hookup and future service. Attach a solid earth ground wire to the GROUND SCREW.

2. Route connecting wires from first ice machine lower junction box and connect to KCMR230 terminal strip connections marked: NO. 1 ICE MACHINE.
3. Route connecting wires from second ice machine lower junction box and connect to stacking kit terminal strip connections marked: NO. 2 ICE MACHINE.
4. Route connecting wires from KCMR230 terminal strip marked: TO REMOTE FAN and connect at the remote condenser junction.

//////////////////// CAUTION //////////////////////
IMPROPER VOLTAGE SUPPLIED TO THE
ICEMAKER WILL VOID YOUR PARTS
REPLACEMENT PROGRAM.
////////////////////////////////////

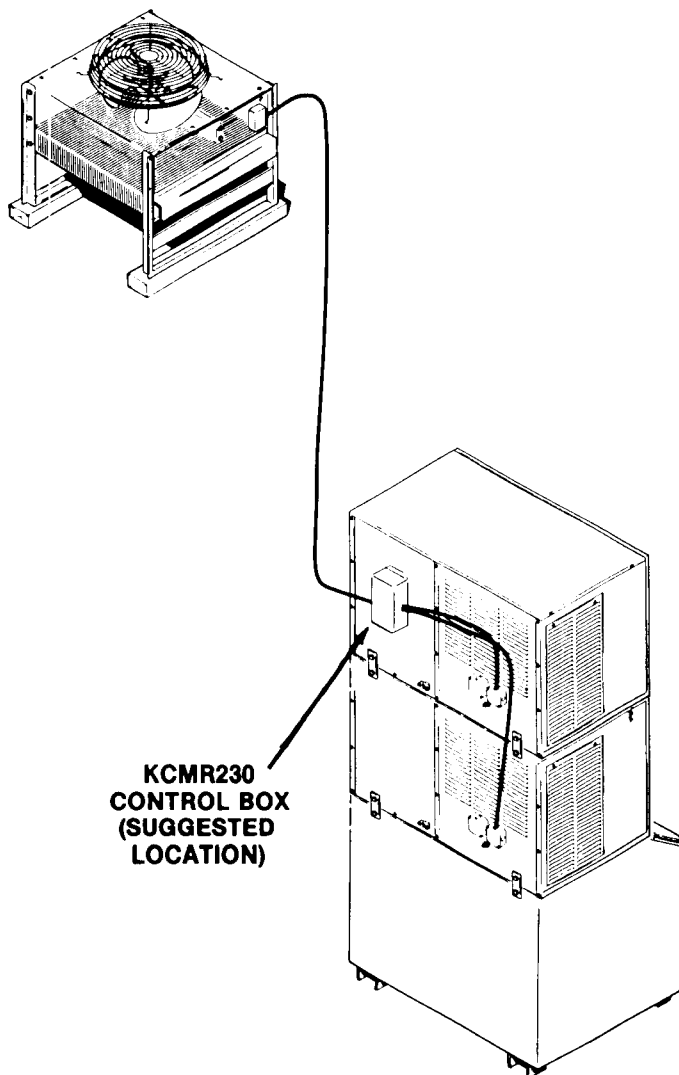

CM855R FOR THE ELECTRICIAN

5. Check phasing of the electrical circuit as follows:

A. The phasing of the wiring **MUST** now be checked, as incorrect wiring will result in a failure of the kit relay.

Below is an illustration of the KCMR230 terminal strip. Note that each terminal is marked: 1 - 2 - 3 - 4 - 5 - 6. For proper phasing:

Terminals #1 and #3 must be connected on the same side of the line (such as L1).

Terminals #2 and #4 must be connected on the same side of the line (such as L2).

B. Make the test with a volt meter as follows:

1. Switch on icemaker #1 first, then switch on icemaker #2. (The compressors must be operating for this test).
2. Test with a volt meter between terminals #2 and #4, then between terminals #1 and #3. Compare the readings obtained to the ones in the following list.

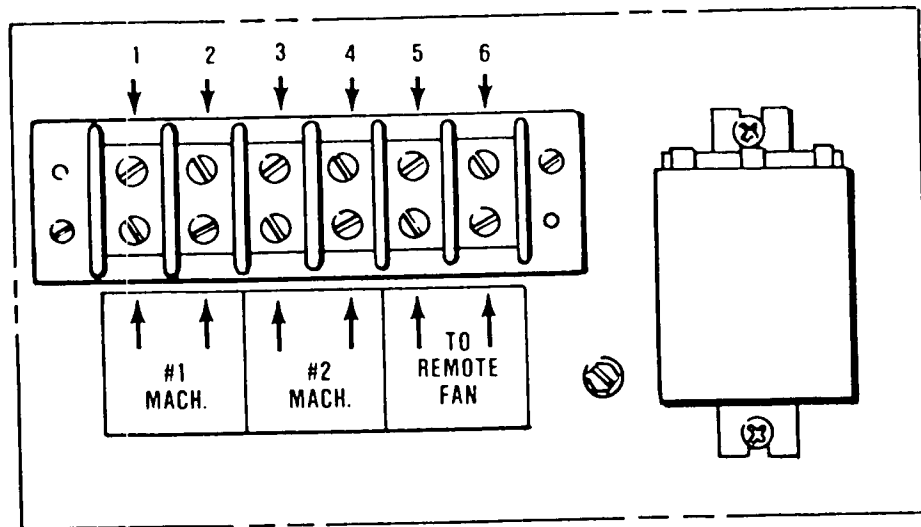

C.

	CORRECT VOLTAGE READINGS
Test terminals 1 - 2	Full voltage (208v-220v)
Test terminals 1 - 3	No voltage
Test terminals 2 - 3	Full voltage
Test terminals 2 - 4	No voltage
Test terminals 3 - 4	Full voltage
Test terminals 1 - 4	Full voltage

D. If there is full voltage where there should be no voltage, turn off icemaker #2, (both toggle switches). Then turn off icemaker #1 (both toggle switches). The connections at the KCMR230 terminal strip marked icemaker #1 must be **reversed** (put the wire that was on 1 on 2 and the wire that was on 2 on 1).

Remember to do all wiring with the electrical power to both icemakers disconnected at the source.

CM855R FOR THE PLUMBER

CONFORM TO ALL APPLICABLE CODES

WATER SUPPLY

Connect a potable water supply to the icemaker water inlet connection. The connection on the unit is a 3/8" male flare. The recommended size water line is 3/8" O.D. copper tubing. When water conditions are doubtful, a test of the water should be made by a water treatment specialist, and their recommendations for filtration and/or treatment should be followed.

DRAIN CONNECTIONS

The drains are gravity type, and must have a minimum of 1/4" fall per foot on horizontal pipe runs. The drains must be installed per local codes. A vent is recommended at the icemaker and bin drain connections. The ideal drain receptical would be a trapped and vented floor drain.

The recommended drain size is 5/8" - 3/4" rigid pipe - the bin drain must be separated from the icemaker's. The bin and icemaker drain connections are 3/4" F.P.T.

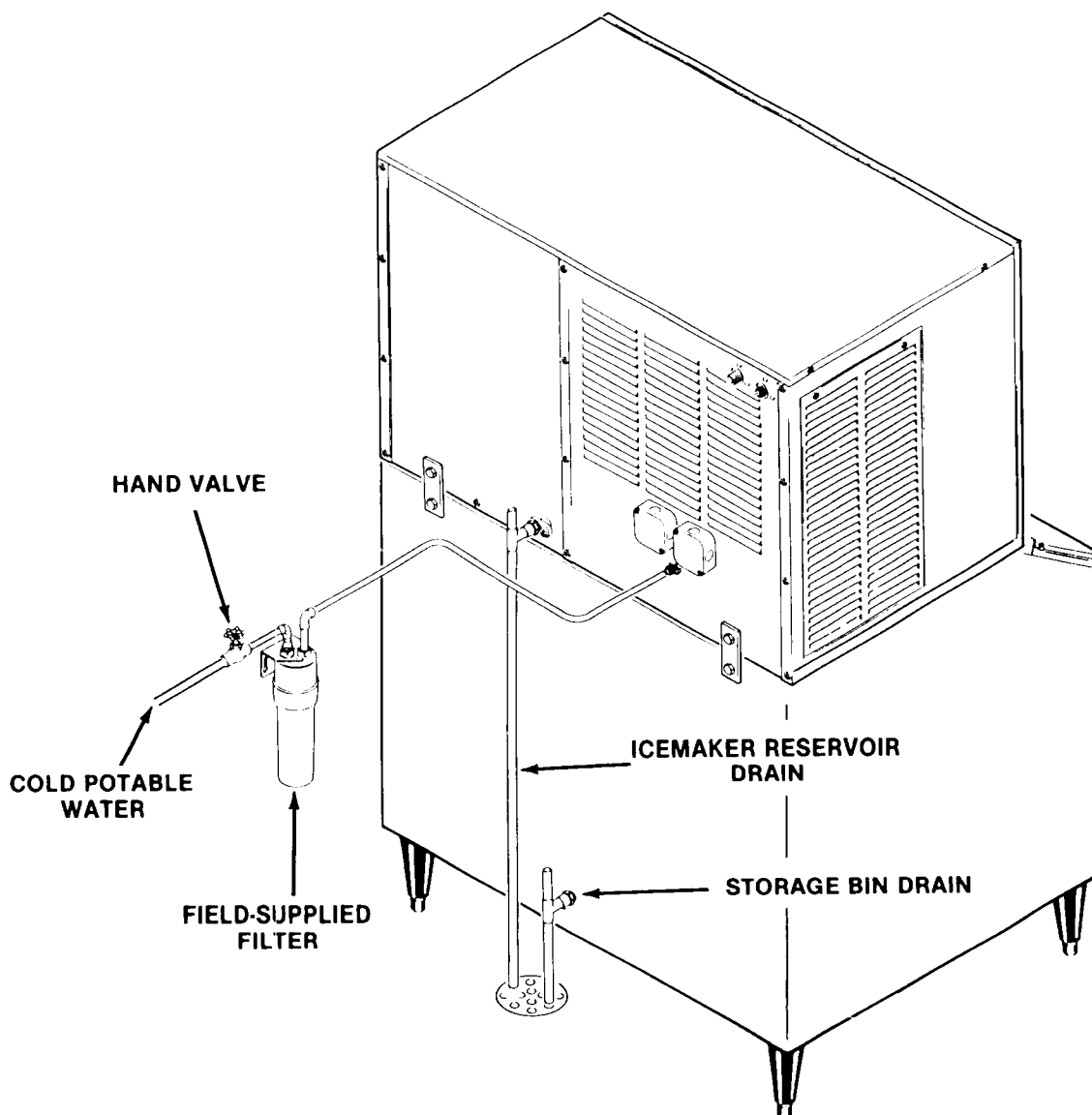

**DRAIN LINES MUST SLOPE TOWARDS THE BUILDING DRAIN
1/4" PER FOOT MINIMUM.**

CM855R FOR THE INSTALLER

FINAL CHECKLIST

1. Is the icemaker and bin in a place where the air and water temperatures are maintained within the manufacturer's limitations?
2. Is the remote condenser installed per local building codes on the roof, where it has adequate ventilation and minimal solar heat gain?
3. Is the icemaker installed with adequate room for machine service?
4. Has the icemaker/bin combination been leveled?
5. Has all shipping material and literature been removed from the units?
6. Has the bin thermostat and bracket been installed?
7. Have all electrical and water connections been made?
8. Is there a hand valve in the water line to the icemaker?
9. Has the unit been wiped clean, and the bin interior sanitized?
10. Have the remote condenser and pre-charged lines been properly installed and connected?
11. Have the connections been checked for leaks?
12. Has the electrical connection between the icemaker and the condenser been made?
13. Verify that the master switch and the Compressor switch are in the **OFF** positions.
14. Switch on the electrical power, and check the voltage.
15. Fill out the registration card, and mail it in to the factory.
16. Refer to **PRE-START INSTRUCTIONS** page 15.

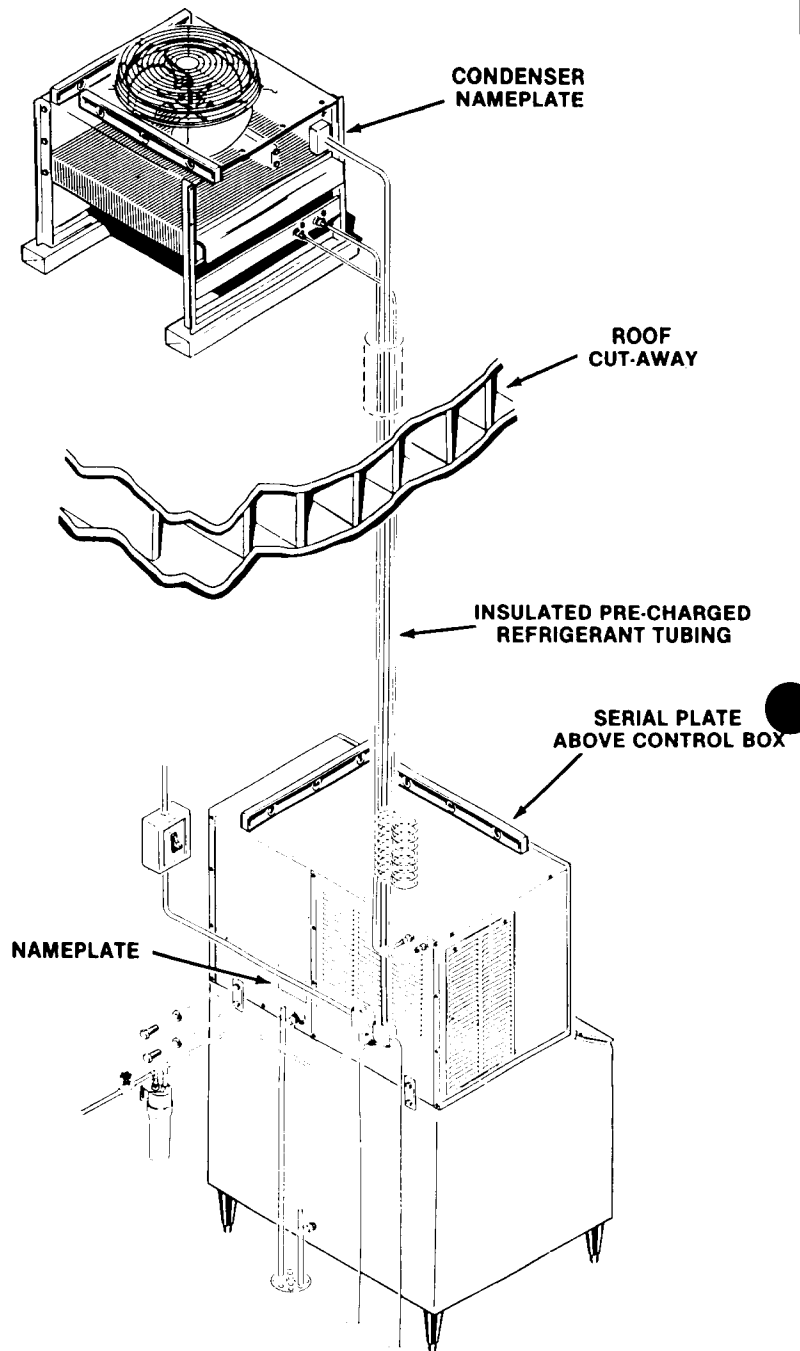

Completed Installation

CM855R START UP

PRE-START

1. Is the location of the equipment proper?
2. Is the electrical voltage correct?
3. Has power to the machine been on for at least 12 hours, and is the compressor dome warm? (Toggle switches on OFF?)
4. Has the water supply been turned on?
5. Is the icemaker level?
6. Are the refrigerant lines for the condenser properly connected and routed?
7. Are the bin thermostat controls mounted in the bracket and is the bracket in the proper mounting spot?

START-UP

1. Go through the Pre-Start check list.
2. Remove front panel by pulling out at the bottom to unsnap and lift off.
3. Remove the control box cover.
4. Remove left side service panel. Check that the King Valve is closed and the compressor is warm.
5. Rotate timer shaft clockwise until the timer cam appears the same as in the illustration.

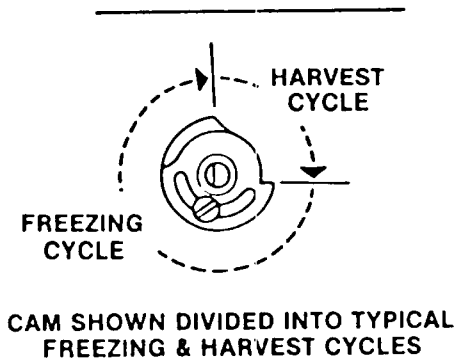
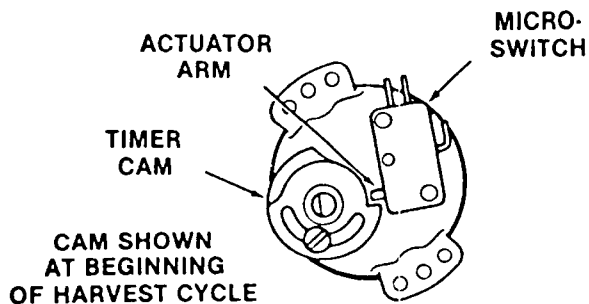

Timer Cam Positions

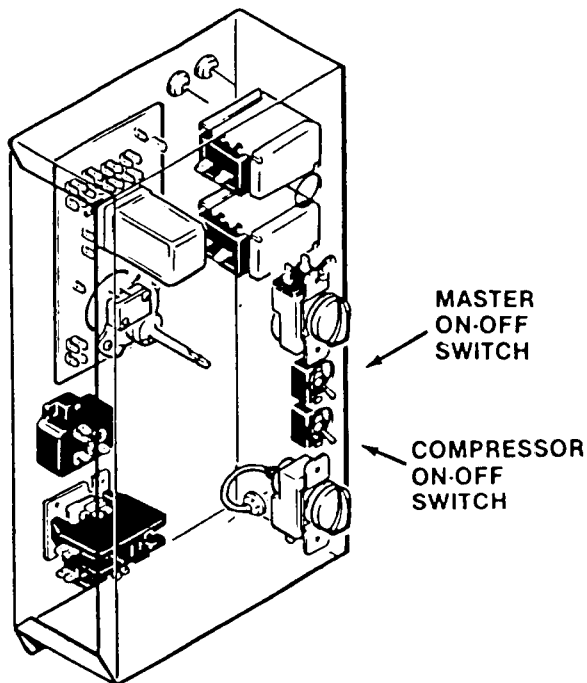

6. Turn the master switch to ON and observe that the inlet water solenoid opens, and water begins to enter the sump, also observe that the timer does advance in a clockwise direction.
7. The timer will move to the end of the harvest position and stop. If the sump is still not full, repeat step 5. When the sump is full the water pump will be circulating water over the evaporator plates. This water is returning to the sump and any excess will be drained out through the overflow standpipe in the sump. When the timer stops, the inlet water stops coming in, but the pump stays on.
8. Open the King Valve located on the receiver.
9. Move the compressor toggle switch to ON. Observe that the sight glass begins to fill with liquid refrigerant and stays full.
10. On the roof, observe that the condenser fan is running.
11. Now the icemaking process begins. The evaporator plates will soon begin to feel cool, and ice begins to form where the water is flowing over the metal portions of the plate.
12. Let the machine function as shipped, but observe the first harvest of cubes. **ADJUSTMENTS MAY BE REQUIRED.**

CM855R START UP — CUBE SIZE

13. Observe second and third cube harvest.

Check size of SCOTSMAN CONTOUR CUBE

Unlike other SCOTSMAN cubes which are made in a definite molded shape, contour cubes are produced in indentations and many shapes and sizes of contour cubes may be produced — only ONE size and shape combination is correct.

An under-charged refrigeration system produces larger cubes at the top of the evaporator plate and smaller cubes at the bottom. Charge system per NAMEPLATE specifications.

Charge Refrigeration System with **REFRIGERANT 502 ONLY.**

In areas where extreme problem water condition exists, filtering or purifying equipment is recommended.

TOO LARGE

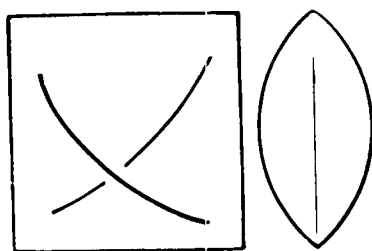

Too LARGE — may cause evaporator freeze ups. Adjust cube size control counter-clockwise to obtain smaller cubes

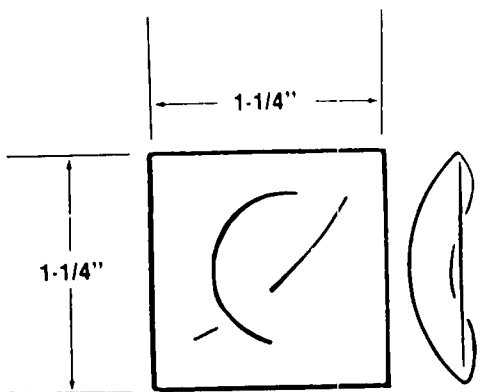

PROPER SIZE AND SHAPE

PROPER SIZE AND SHAPE of the contour cube. Icemaker operates at peak efficiency when a cube this size and shape is produced. A finely tuned system produces vertical strips of ice which easily break when they fall.

Normal harvest will be the top few rows of cubes first, then the lower rows.

TOO SMALL

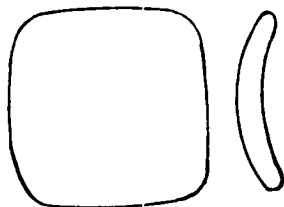

TOO SMALL. To obtain proper size cubes, adjust cube size control clockwise. May cause freeze up problems due to poor harvest.

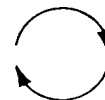

Ice Cube Size & Shape

CM855R START UP — HARVEST TIME

14. Check the Harvest time. The correct setting is one that allows enough time for all of the ice to fall from the evaporators and to fill the sump, with water to the overflow point, plus 15-30 seconds extra time.

To adjust the timer:

- A. Disconnect electrical power supply to the icemaker.
 - B. Loosen the screw on the timer that locks the two cams together.
 - C. To decrease Harvest time, rotate the shaft of the timer counter-clockwise. To increase, turn the shaft clockwise.
 - D. Retighten the screw to lock the two cams together again.
 - E. Return power to icemaker. Check cube size and Harvest time.
15. Check texture of ice cubes; when partially cloudy throughout, suggests icemaker is operating short of water; or, possibly an extreme problem water condition exists, wherein filtering or purifying equipment is recommended.

BIN THERMOSTAT OPERATION

With the icemaker in the harvest cycle, hold ice against the bin thermostat control bulb to test shutoff at the **END OF THE HARVEST CYCLE**. If the bin thermostat is **OPEN**, the liquid line solenoid valve will close, shutting off refrigeration flow to the evaporator and allowing the compressor to pump any refrigerant left in the evaporators into the high pressure receiver. When the evaporator pressure is lowered to approximately 20 PSIG, the low pressure switch opens, shutting off the compressor, remote fan and water pump.

Within minutes after the ice is removed from the sensing bulb, the bulb will warm up and cause the icemaker to restart. This control is factory set and should not be reset until testing is performed.

16. Replace control box cover and all cabinet panels and screws.
17. Thoroughly explain to the owner/user the significant specifications of the icemaker, the start up and operation, going through the procedures in the operating instructions. Answer all questions about the icemaker by the owner; and inform the owner of the name and telephone number of the authorized SCOTSMAN Distributor, or service agency serving him.

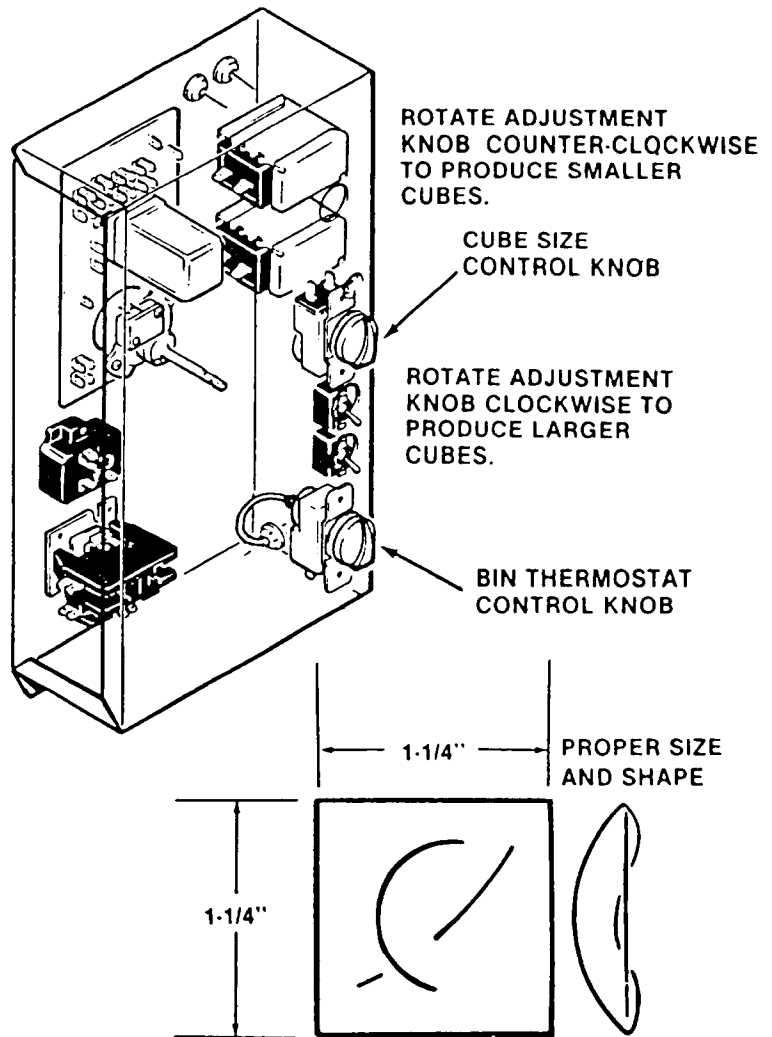

Cube Size Control Adjustment

CM855R OPERATION

REFRIGERATION SYSTEM - SCHEMATIC DIAGRAM

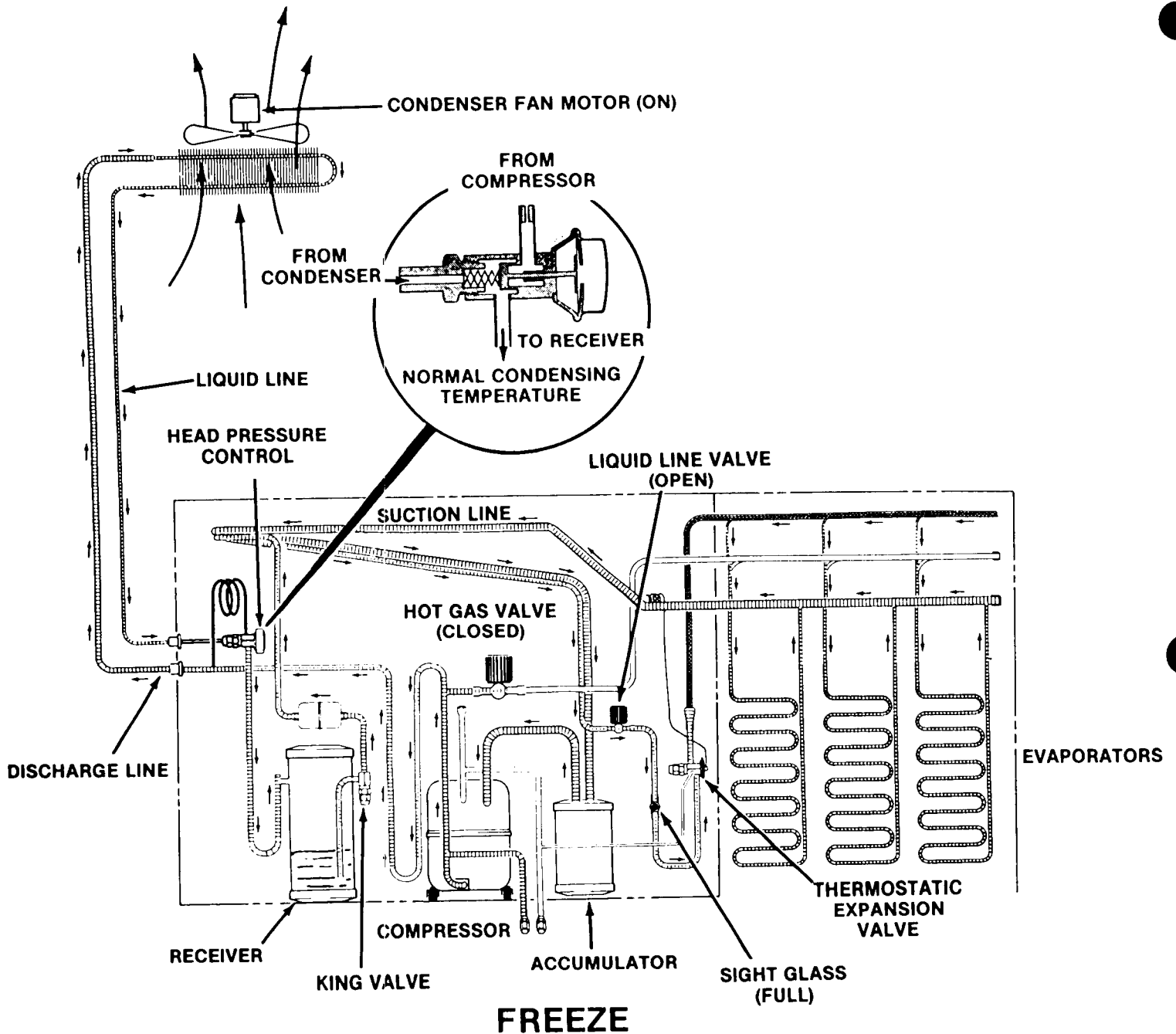

During the freeze cycle, at a normal condenser air temperature, the discharge gases from the compressor go through the discharge line up to the remote condenser, where the removal of heat causes the refrigerant to condense into liquid. The liquid refrigerant, still under high pressure, moves down to the ice machine, passing through the head pressure control, which is open because of the normal head pressure, and into the receiver. The receiver discharge connection picks up liquid refrigerant from near the base of the receiver and the refrigerant then moves through the liquid line

solenoid valve (open at this time) up to the thermostatic expansion valve. At the TXV, the liquid refrigerant is metered into the evaporators, where the internal pressure is much reduced. This causes the refrigerant to rapidly "evaporate" or boil off, absorbing heat from the evaporators and the water being pumped over them. The refrigerant, now a low pressure gas, moves towards the compressor suction port. It goes through an accumulator in the system to insure no liquid refrigerant reaches the compressor and then to the compressor, where the cycle is repeated.

CM855R OPERATION

REFRIGERATION SYSTEM - SCHEMATIC DIAGRAM

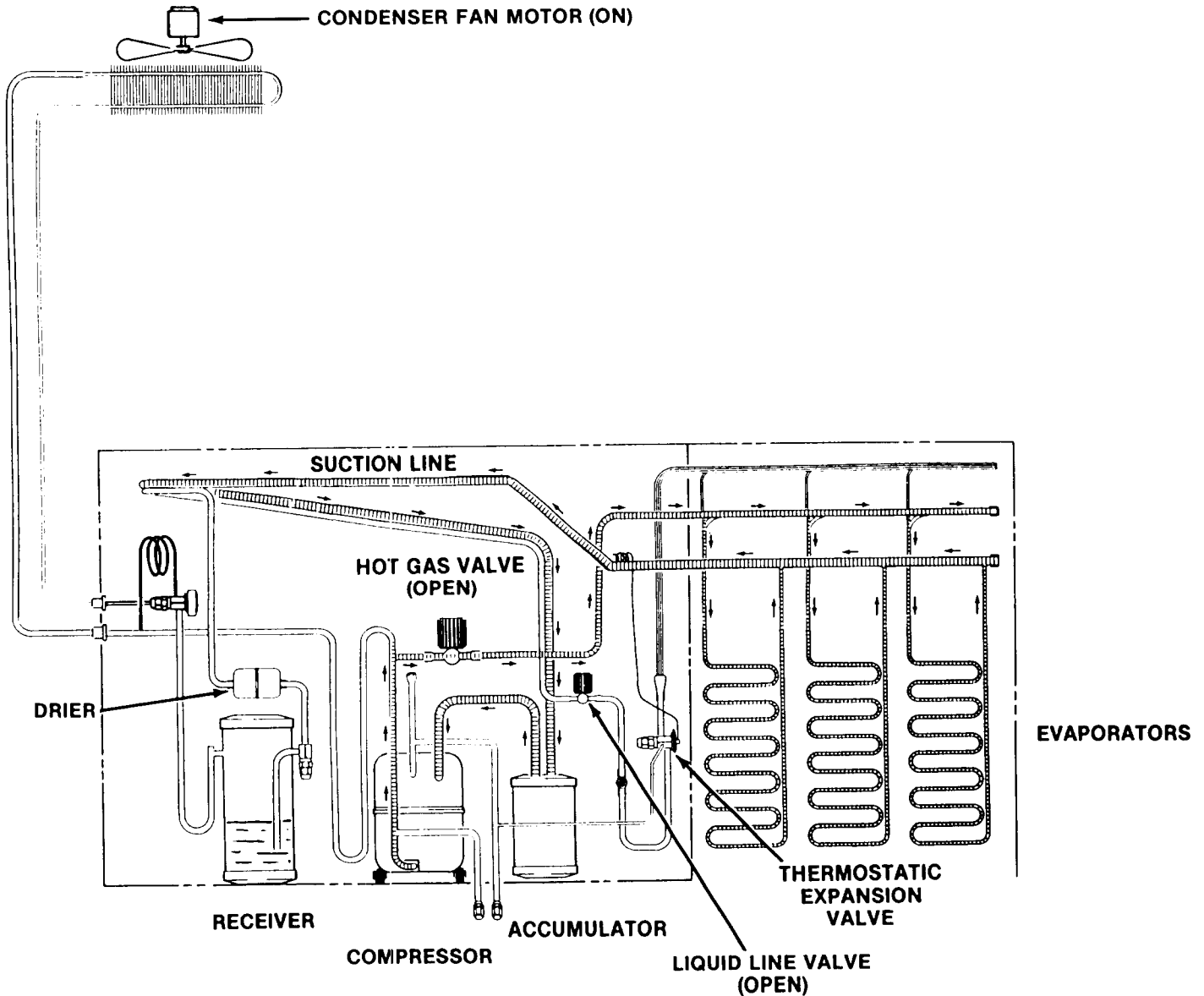

HARVEST

REFRIGERATION CYCLE, HARVEST

During the timed harvest cycle, the hot, high pressure refrigerant gases move through the discharge line, into the open hot gas valve, by-passing the remote condenser and the receiver. From the hot gas valve, the refrigerant flows into the evaporators, where the hot gases condense, giving off heat. It is this heat that, transferred to the evaporators, warms them up.

That causes the ice to be released from the evaporator surface, so it falls, by gravity, into the storage bin.

After the refrigerant has gone through the evaporators, it enters the accumulator, and from there back to the compressor.

CM855R OPERATION

REFRIGERATION SYSTEM - SCHEMATIC DIAGRAM

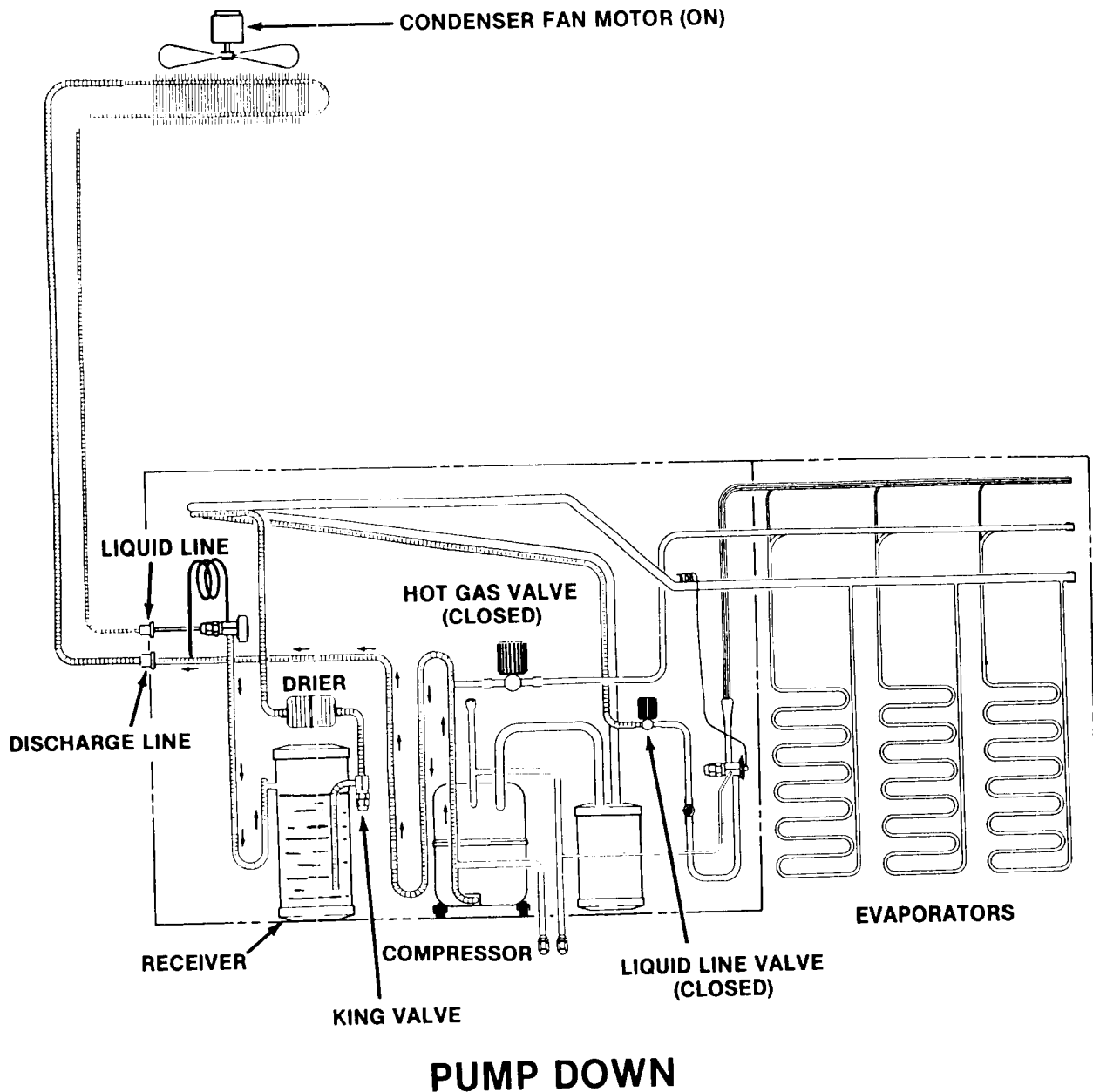

REFRIGERATION SYSTEM, PUMP-DOWN

During the pump-down cycle (usually initiated by the bin thermostat being open, shutting the machine off) the discharge gases from the compressor follow their normal route to the remote condenser, through the head pressure control, and into the receiver. At this point the

refrigerant flow is stopped by the closed liquid line valve. This action forces the refrigerant into the receiver, and keeps it out of the compressor. The pump-down continues until the low pressure control turns the compressor off.

CM855R OPERATION

REFRIGERATION SYSTEM - SCHEMATIC DIAGRAM

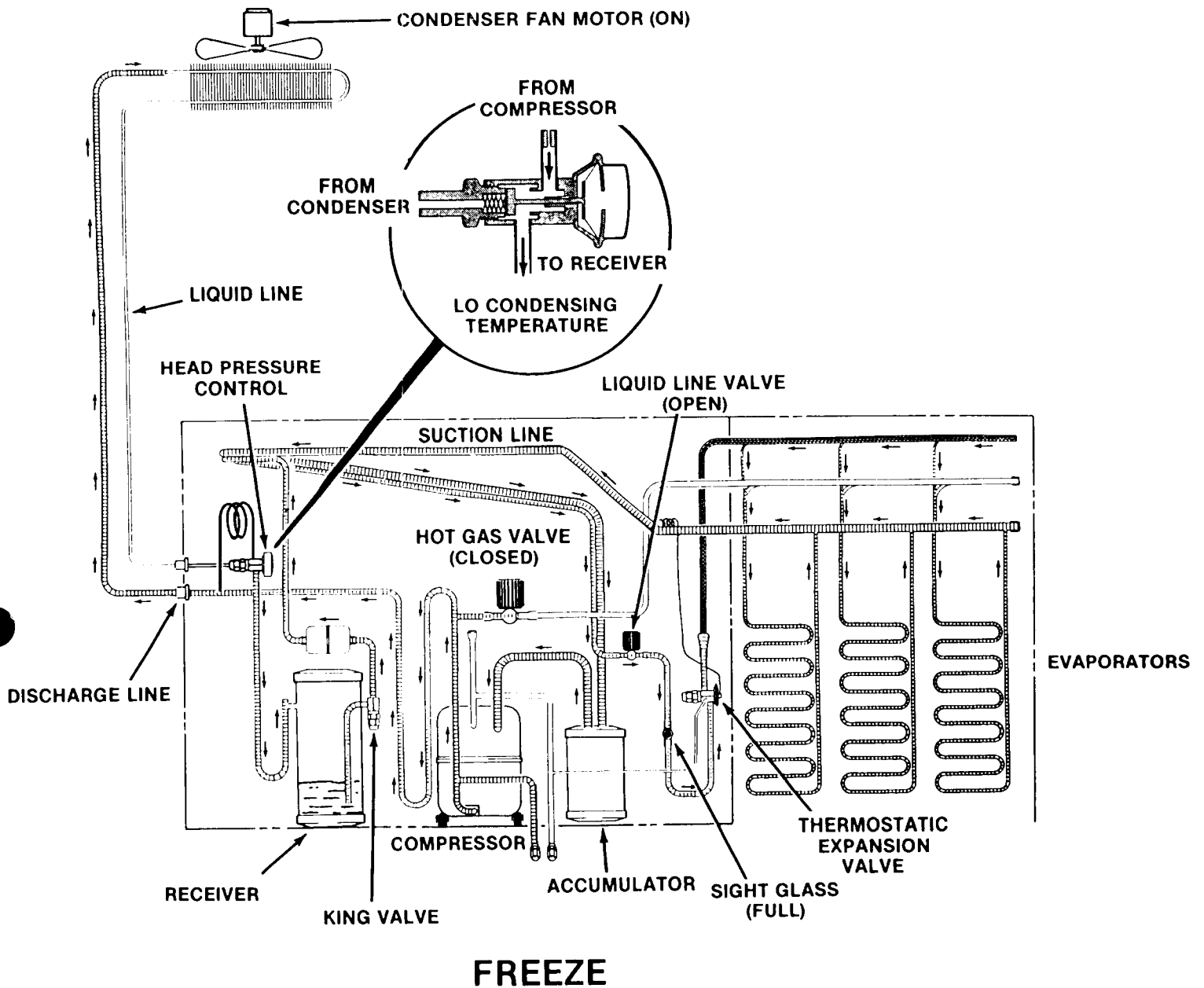

REFRIGERATION SYSTEM

LOW CONDENSER AIR TEMPERATURE

The freezing cycle under low condenser air temperatures is the same as the normal cycle, with the exception that the resulting low head pressures cause the head pressure control to close off the liquid line between the condenser and the receiver. This forces more refrigerant into the condenser (with a small amount of

discharge gas going into the receiver to maintain pressure until the head pressure is built back up to the rated gauge pressure (220 PSIG), where the valve re-opens the passage between the condenser and the receiver.

CM855R OPERATION

WATER SYSTEM - SCHEMATIC DIAGRAM

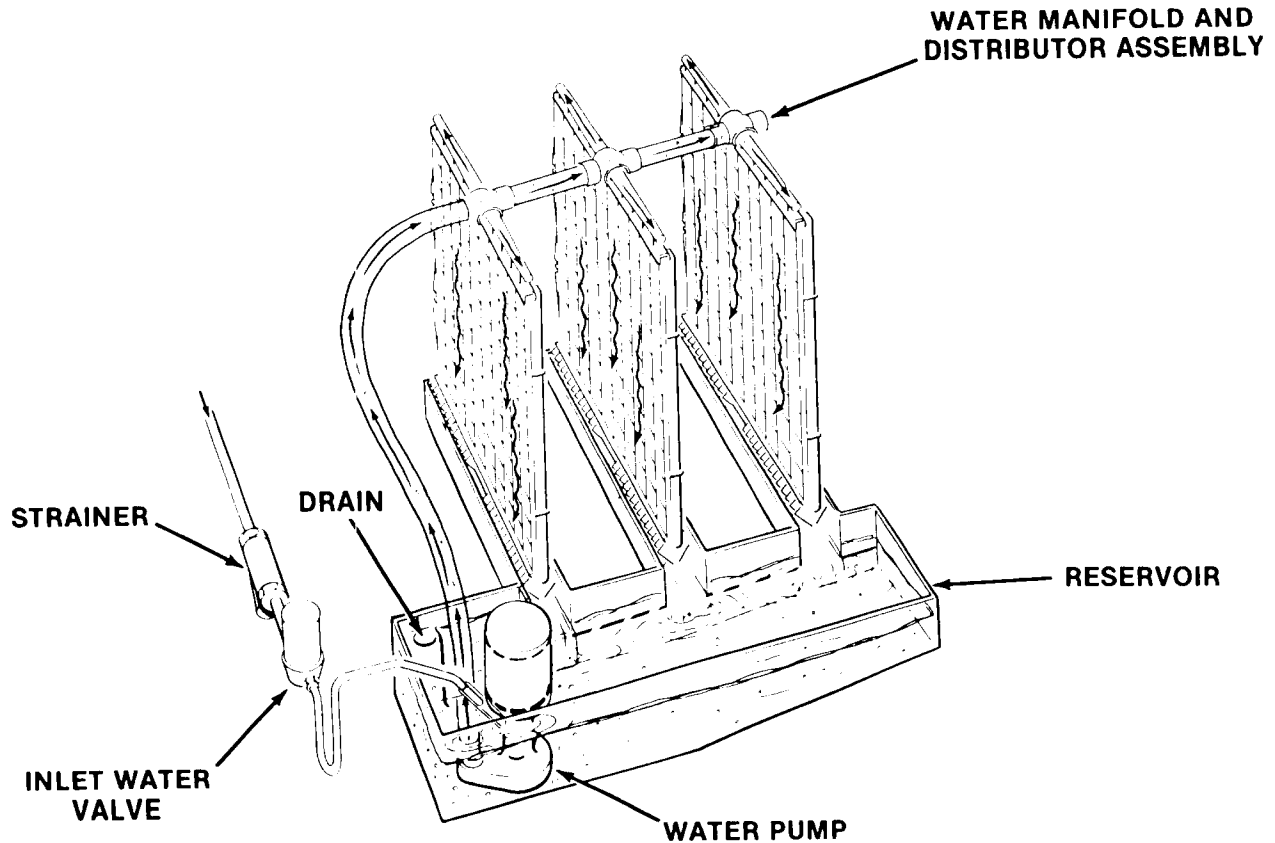

WATER FLOW SCHEMATIC

WATER SYSTEM

FREEZE

The water system during freeze consists of a fixed volume of water being continuously recirculated over the freezing surfaces of the evaporator, by means of a water pump. The pump forces the water to the top of each evaporator, from there it cascades down into the return trough the back to the reservoir where the pump is. As the unit freezes ice, the water level in the reservoir will drop.

HARVEST

The only change is that the inlet water valve has come on, letting in make-up water to fill the reservoir. Once it is full, excess water is drained out the reservoir, via a stand pipe. This excess water dilutes the possible concentration of minerals that can be expected to remain in the water after ice is formed.

CM855R OPERATION - ELECTRICAL SEQUENCE

The following charts illustrate which switches and which components are ON or OFF during a particular phase of the icemaking cycle.

Refer to the wiring diagram for a reference. Remember, the wiring diagram shows the unit as it is in the Timed Freeze Cycle.

BEGINNING FREEZE

ELECTRICAL COMPONENTS (LOADS)	ON	OFF
Crankcase Heater	X	
Compressor	X	
Fan Motor	X	
Hot Gas Valve		X
Inlet Water Valve		X
Liquid Line Valve	X	
P.C. Board Relay Coil	X	
Timer		X
Water Pump	X	

SWITCHES	ON	OFF
Bin Thermostat	X	
Cube Size Thermostat		X
Toggle	X	
L.P. Control	X	
H.P. Control	X	
Timer Micro Switch N.C.		X
Timer Micro Switch N.O.	X	
High Temp Switch	X	

At the beginning of the freeze cycle, the timer is not turning, but the icemaker is refrigerating the water, starting to turn the water into ice.

CM855R OPERATION - ELECTRICAL SEQUENCE

TIMED FREEZE

ELECTRICAL COMPONENTS (LOADS)	ON	OFF
Crankcase Heater	X	
Compressor	X	
Fan Motor	X	
Hot Gas Valve		X
Inlet Water Valve		X
Liquid Line Valve	X	
P.C. Board Relay Coil	X	
Timer	X	
Water Pump	X	

SWITCHES	ON	OFF
Bin Thermostat	X	
Cube Size Thermostat	X	
Toggle	X	
L.P. Control	X	
H.P. Control	X	
Timer Micro Switch N.C.		X
Timer Micro Switch N.O.	X	
High Temp Switch	X	

After the icemaker has cooled the water and formed some ice on the evaporator, the evaporator will have gotten cold enough to have the cube size control close. All this does is start and run the timer.

HARVEST

ELECTRICAL COMPONENTS (LOADS)	ON	OFF
Crankcase Heater	X	
Compressor	X	
Fan Motor	X	
Hot Gas Valve	X	
Inlet Water Valve	X	
Liquid Line Valve	X	
P.C. Board Relay Coil		X
Timer	X	
Water Pump	X	

SWITCHES	ON	OFF
Bin Thermostat	X	
Cube Size Thermostat		X
Toggle Switch	X	
L.P. Control	X	
H.P. Control	X	
Timer Micro Switch N.C.	X	
Timer Micro Switch N.O.		X
High Temp Switch	X	

The timer has now turned far enough so that the micro-switch plunger has dropped into the gap in the cam. This breaks the circuit to the relay in the P.C. Board - and that puts the machine into the Harvest cycle, where the hot gas valve and inlet water valve have opened to harvest the ice.

CM855R OPERATION - ELECTRICAL SEQUENCE

PUMP DOWN - STAGE ONE

ELECTRICAL COMPONENTS (LOADS)	ON	OFF
Crankcase Heater	X	
Compressor	X	
Fan Motor	X	
Hot Gas Valve		X
Inlet Water Valve		X
Liquid Line Valve		X
P.C. Board Relay Coil		X
Timer		X
Water Pump	X	
SWITCHES		
Bin Thermostat		X
Cube Size Thermostat		X
Toggle	X	
L.P. Control	X	
H.P. Control	X	
Timer Micro Switch N.C.	X	
Timer Micro Switch N.O.		X
High Temp Switch	X	

When ice is on the bin control, it will OPEN and at the end of the Harvest Cycle, this will initiate a pump down cycle. The liquid line valve (normally closed) will close and the compressor will pump refrigerant into the receiver.

PUMP DOWN - STAGE TWO

ELECTRICAL COMPONENTS (LOADS)	ON	OFF
Crankcase Heater	X	
Compressor		X
Fan Motor		X
Hot Gas Valve		X
Inlet Water Valve		X
Liquid Line Valve		X
P.C. Board Relay Coil		X
Timer		X
Water Pump		X
SWITCHES		
Bin Thermostat		X
Cube Size Thermostat		X
Toggle (Master and Compressor)	X	
L.P. Control		X
H.P. Control	X	
Timer Micro Switch N.C.	X	
Timer Micro Switch N.O.		X
High Temp Switch	X	

After the low side pressure has dropped under 20 psig, the compressor will be turned off by the low pressure control and the unit will be pumped down, OFF and in a standby mode.

CM855R SERVICE SPECIFICATIONS

In servicing a machine, it is often useful to compare that individual units operating characteristics to those of a normally operating machine. The data that follows give those characteristics. However, be aware that these values are for NEW, CLEAN machines. USE THESE NUMBERS AS A GUIDELINE ONLY.

COMPONENT

Timer - 1 revolution of the cam, in minutes	8
Harvest Time, preset, in minutes	2-1/4
Inlet Water Valve, water flow in g.p.m.	1

	CI	CO
Cube Size Control, Reverse Acting, Temperature range	(+ 15°F. to - 3°F.)	—
Bin Thermostat, Temperature Range	38.5°-43.5°	33.5°-38.5°
Low Pressure Control, (Pump Down) psig	35	20
High Pressure Safety Switch, psig	manual	400

The head pressure regulating valve will maintain a minimum discharge pressure during the freezing cycle, in excess of 200 PSIG.

OPERATING CHARACTERISTICS

The values listed below are representative of values seen at a wide range of air and water temperatures and are for a normal cube size.

FREEZE CYCLE

Average Discharge Pressure	325-220 PSIG
Suction Pressure at the end of the Freeze Cycle	25-21 PSIG
Freeze Time	17-26 Minutes
Total Amp Draw	8-11

HARVEST CYCLE

Average Discharge Pressure	200-100 PSIG
Average Suction Pressure	180-130 PSIG
Harvest Time, assumed to be 2-1/4 minutes. This can be adjusted to suit local conditions.	
Total Amp Draw	9-12

When comparing these figures to field data, allow a variation from each end of the range given.

TO SERVICE REFRIGERATION SYSTEM:
TORQUE REFRIGERATION ACCESS VALVE
CAPS TO 60-75 INCH POUNDS.

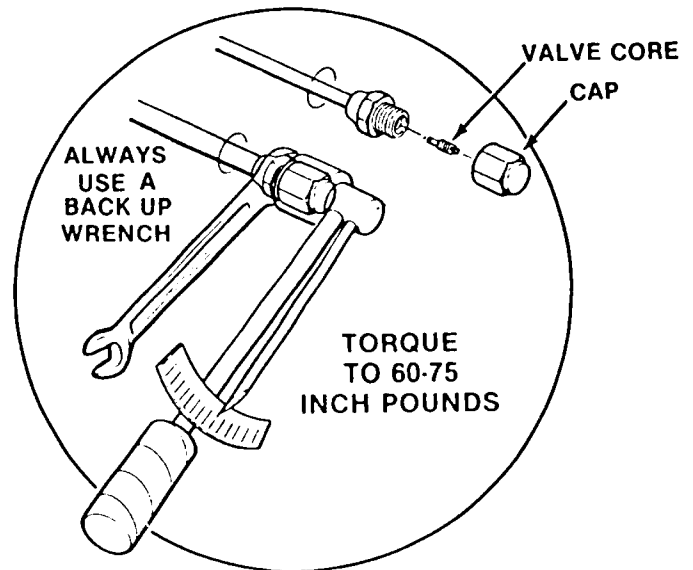

ALWAYS USE A BACK-UP
WRENCH TO AVOID DAMAGE
TO THE REFRIGERANT TUBING.

CM855R MAINTENANCE & CLEANING INSTRUCTIONS

////////////////////////////////////
A Scotsman Ice System represents a sizable investment of time and money in any company's business. In order to receive the best return for that investment, it MUST receive periodic maintenance.

It is the USER'S RESPONSIBILITY to see that the unit is properly maintained. It is always preferable; and less costly in the long run, to avoid possible down time by keeping it clean, adjusting it as needed and by replacing worn parts before they can cause failure. The following is a list of recommended maintenance that will help keep your machine running with a minimum of problems.

Maintenance and Cleaning should be scheduled at a MINIMUM of twice per year.
////////////////////////////////////

ICEMAKER

THE FOLLOWING MAINTENANCE SHOULD BE SCHEDULED AT LEAST TWO TIMES PER YEAR ON THIS ICEMAKER. CALL YOUR AUTHORIZED SCOTSMAN SERVICE AGENCY.

1. Check and clean or service any optional water treatment devices, if any installed.
2. Clean water strainer.
3. Check that the cabinet is level, in the side-to-side and front-to-back directions.
4. Clean the water system, evaporator plate and sump assembly, using a solution of SCOTSMAN Ice Machine Cleaner. Refer to CLEANING - Icemaker.

Cleaning requirements vary according to local water conditions and individual user operation. Continuous check of the clarity of ice cubes and visual inspection of the water system parts, evaporator plates and the sump assembly before and after cleaning will indicate frequency and procedure to be followed in local areas.

5. Check and tighten all bolts and screws.
6. Check for water leaks and make corrections.
7. Check the bin thermostat control bulb to test shut off. Holding ice against bin thermostat control bulb should cause the icemaker to shut off at the end of the harvest cycle.

Within minutes after ice is removed from the bin thermostat control bulb, the icemaker will restart.
8. Check cube size, adjust if required.
9. Check harvest time, adjust if required.

ICE STORAGE BIN

The interior liner of the bin is in contact with a food product, ice, and should be cleaned regularly. Once a week cleaning with soap and water, and after that a hot water rinse with an air dry should be adequate. Commercial food grade sanitizers are available, and may be used.

CM855R MAINTENANCE & CLEANING INSTRUCTIONS

CLEANING - Icemaker

1. Empty bin of ice.
2. Pull out and remove front panel.
3. Switch the master switch to OFF, after the unit shuts off, switch the compressor switch to OFF.
4. Remove the evaporator cover by lifting up, and pulling out.
5. Switch the master switch to CLEAN, pour 8 oz. of Scotsman Ice Machine Cleaner into the water reservoir. Run unit for 30 minutes.

WARNING

SCOTSMAN Ice Machine Cleaner contains Phosphoric and Hydroxyacetic acids. These compounds are corrosive and may cause burns. If swallowed, DO NOT induce vomiting. Give large amounts of water or milk. Call physician immediately. In case of external contact, flush with water. KEEP OUT OF THE REACH OF CHILDREN.

6. Switch the master switch to OFF. Remove the pump hose from the evaporator water manifold, point it into the bin (or a pail) and switch the master switch to ON. This pumps the cleaning solution out of the reservoir. Add fresh water to thoroughly rinse the reservoir.
7. Replace pump hose.
8. Remove control box cover, turn timer shaft clockwise until it appears as illustrated (harvest cycle). Replace cover.

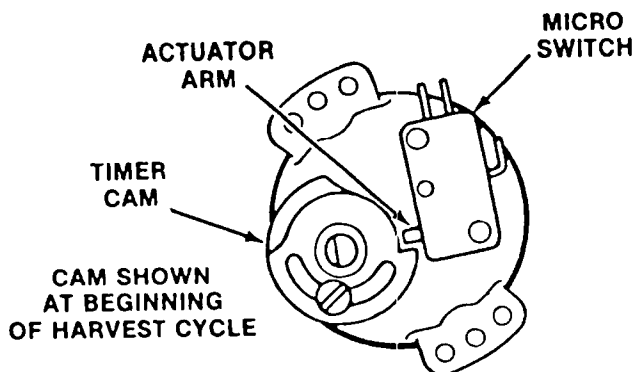

9. Switch the compressor and master switches ON.

CAUTION

DO NOT use ice cubes produced from the cleaning solution. Be sure none remains in the bin.

10. Replace the evaporator cover and front panel.
 11. Check the next batch of cubes to be sure all the cleaner is gone (no sour taste).
 12. Pour hot water into the storage bin to melt the cubes, and to also clean out the bin drain.
- Sanitize the bin, using an approved sanitizing solution, once per week.
- If necessary, the water reservoir can be removed for cleaning by:
- a) Removing the front panel.
 - b) Switching the master switch to OFF.
 - c) Removing evaporator cover.
 - d) Removing thumb screw securing the pump to the lower evaporator brace, unplug pump, pull it up and out of the machine. Remove hose from pump.
 - e) Disconnect drain hose from left rear of the reservoir, lift reservoir up and pull out off machine.
 - f. Reverse to reassemble.

CM855R MAINTENANCE & CLEANING INSTRUCTIONS

REMOTE CONDENSER

Frequent cleaning and inspection of the condenser should be performed to maintain maximum efficiency of Icemaker. A dirty condenser or blocked air flow will greatly decrease icemaking efficiency.

1. With building source electrical power OFF to the icemaker, clean the remote condenser fins, using a vacuum cleaner, whisk broom or brush. **DO NOT USE A WIRE BRUSH.** Instruct customer to clean frequently.

2. Check that fan blade moves freely, is not bent or out of balance; and, the wire guard is properly installed and securely attached.
3. Check that the roof area immediately surrounding the remote condenser is free and clear of any debris that may collect, such as leaves, paper, trash, etc.

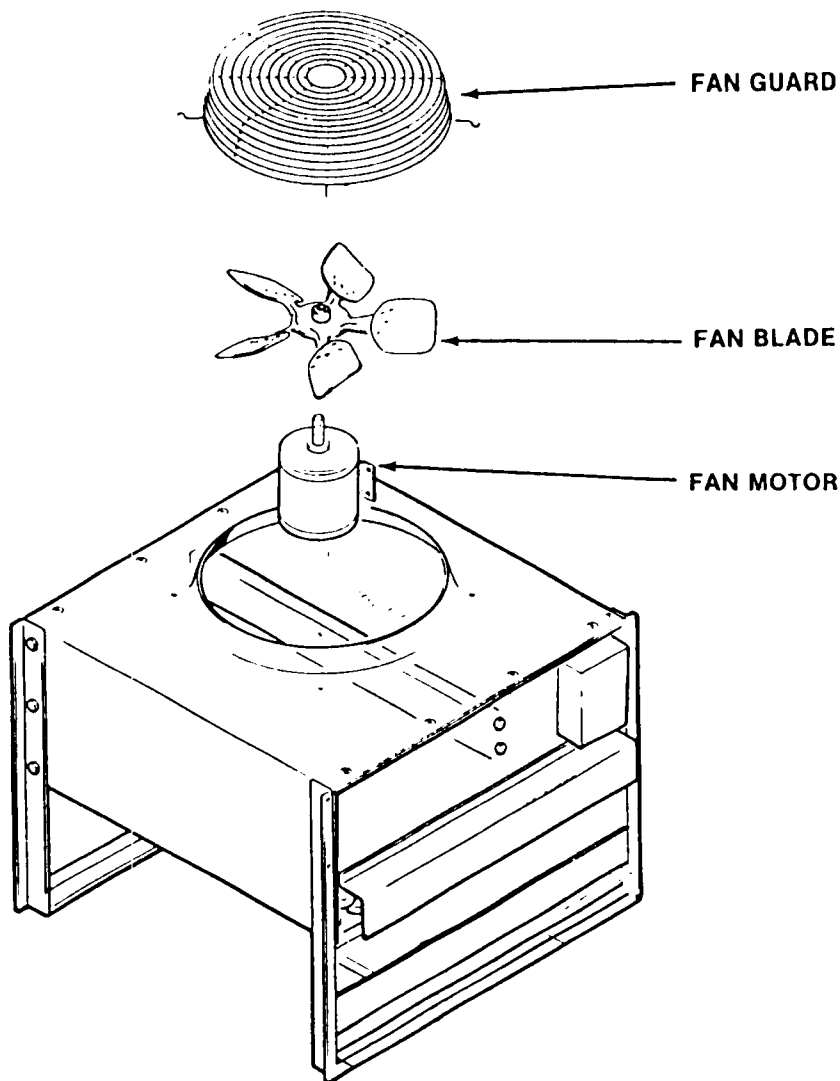

CM855R COMPONENT LOCATION AND DESCRIPTION

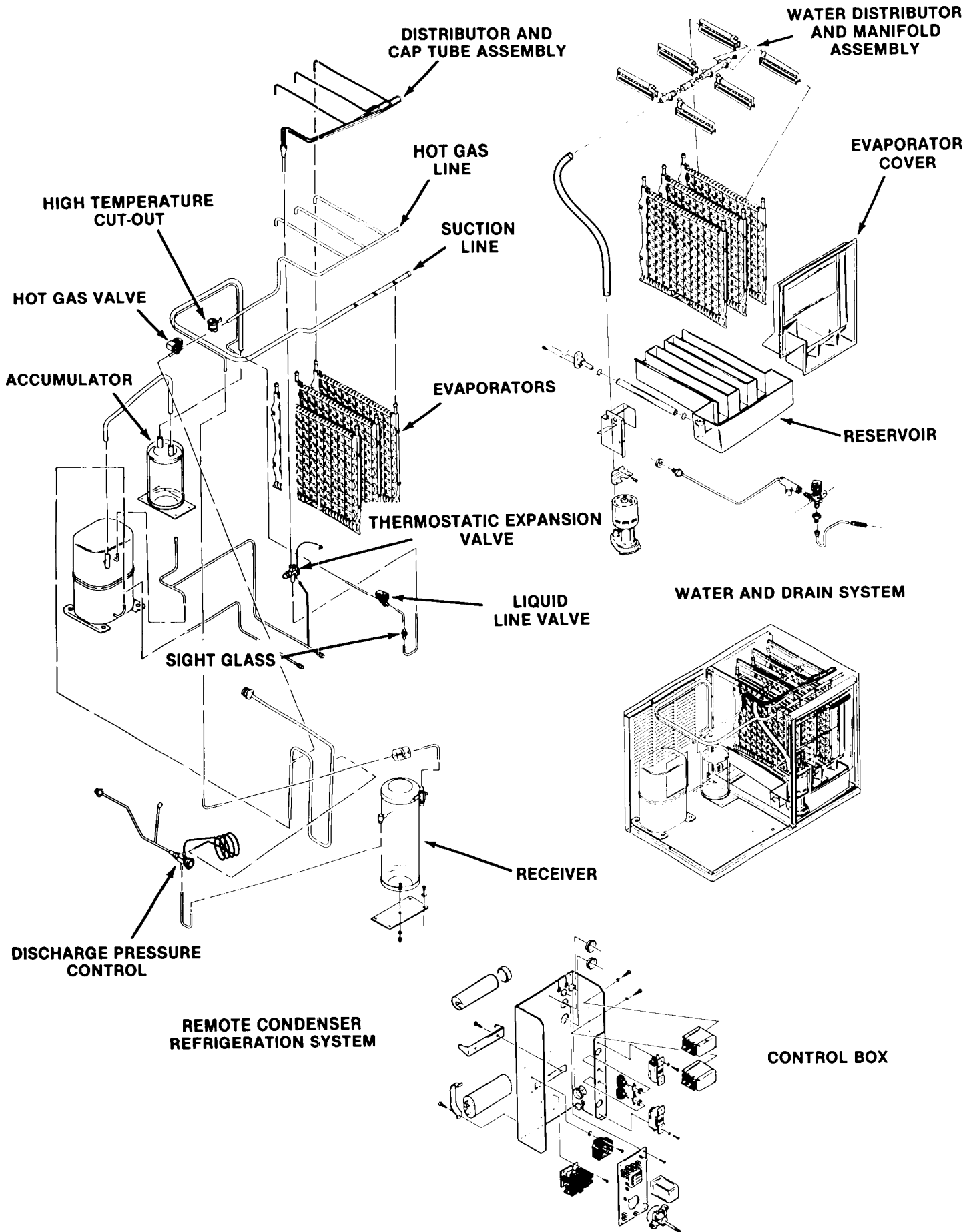

CM855R COMPONENT LOCATION AND DESCRIPTION

WATER SYSTEM

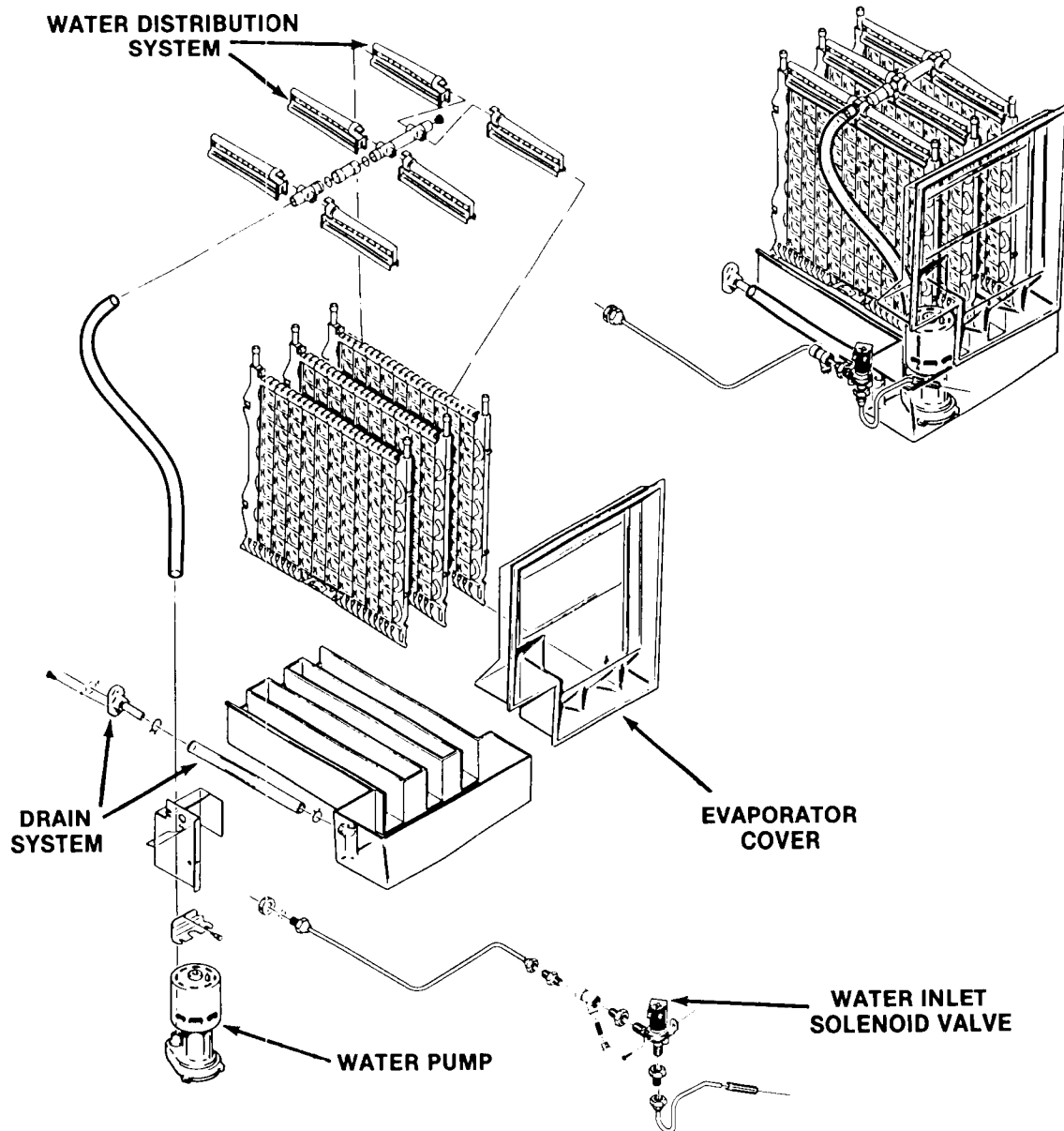

WATER INLET SOLENOID VALVE

The water inlet solenoid valve opens during harvest to fill the sump assembly with water. Excess water overflows through a stand pipe located at the back of the sump to flush minerals from the sump.

WATER PUMP

The water pump picks up water from the base of the reservoir, and forces it up to the top of the evaporators. It remains on throughout the freeze and harvest cycles.

EVAPORATOR COVER

This cover, held in place by shoulder screws, covers the freezing compartment front, keeping any ice and water from splashing the front panel and the water pump.

DRAIN SYSTEM

The drain system functions to allow the excess water brought into the machine during the harvest cycle, to be easily drained away. A standpipe in the back of the reservoir maintains the water level, and is connected to the cabinet drain fitting by tygon tubing.

WATER DISTRIBUTION SYSTEM

The water distribution system functions to evenly supply water to all cells of the evaporator plates. The water pump pumps water from the sump up to the vertical tygon tube to a tee. From there water is channeled through water manifolds to the water distributors, two atop each evaporator plate, and distributed evenly down both sides of each evaporator plate. Gravity flow returns the water to the sump reservoir for recirculation.

CM855R COMPONENT LOCATION

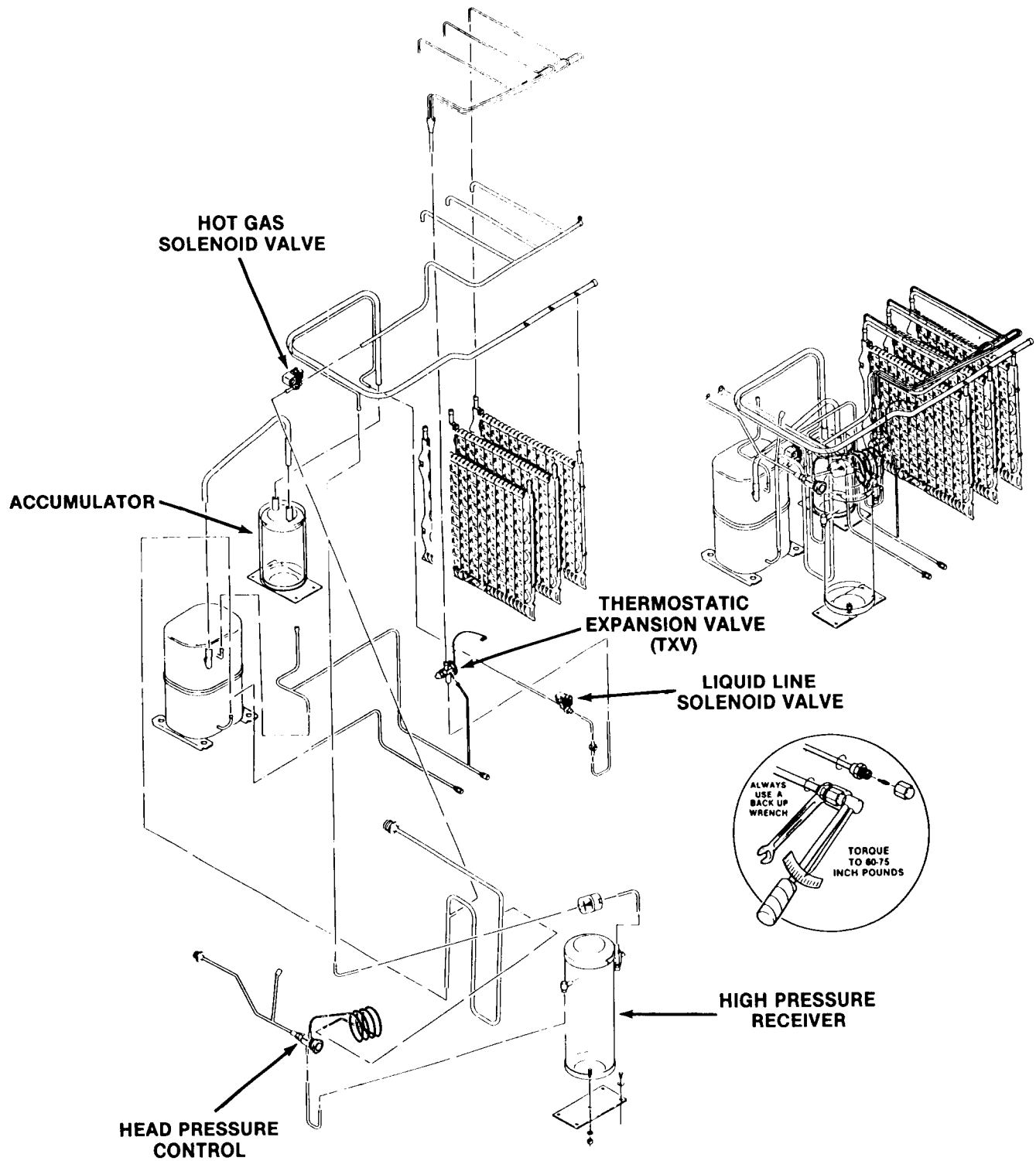

CM855R COMPONENT DESCRIPTION

REFRIGERATION SYSTEM

HIGH PRESSURE RECEIVER

Provides storage volume for refrigerant during cross ambient operation. The high pressure receiver is sized large enough to hold the entire refrigerant charge. During cold operation there is enough liquid in the receiver to maintain a liquid seal to the liquid line.

LIQUID LINE SOLENOID VALVE

The liquid line solenoid valve provides positive shutoff of refrigerant flow for off cycle evaporator pump down.

HOT GAS SOLENOID VALVE

The hot gas solenoid valve opens during the harvest cycle to divert the hot discharge gas from the compressor, directly into the evaporator plates assembly to release ice cubes from the ice cube molds. The hot gas solenoid valve is comprised of two parts, the body and plunger and the coil and frame assemblies. Installed in the discharge line of the compressor, the energized solenoid coil lifts the valve stem within the valve body, to cause the hot discharge gas to be diverted when the finishing timer has advanced to the start of the harvest cycle.

THERMOSTATIC EXPANSION VALVE (TXV)

The thermostatic expansion valve regulates the flow of refrigerant to the evaporator and reduces pressure of liquid refrigerant from condensing pressure to evaporating pressure.

ACCUMULATOR

The accumulator traps liquid overfeed from the evaporator during harvest and meters it into the compressor at a controlled rate.

HEAD PRESSURE CONTROL

This control's function is to maintain the discharge pressure during the freeze cycle. If the condenser air temperature should drop, the head pressure control will block off the liquid line, forcing more refrigeration into the condenser, until the head pressure rises to normal, then the liquid line will be opened.

CM855R COMPONENT LOCATION AND DESCRIPTION

CONTROL BOX

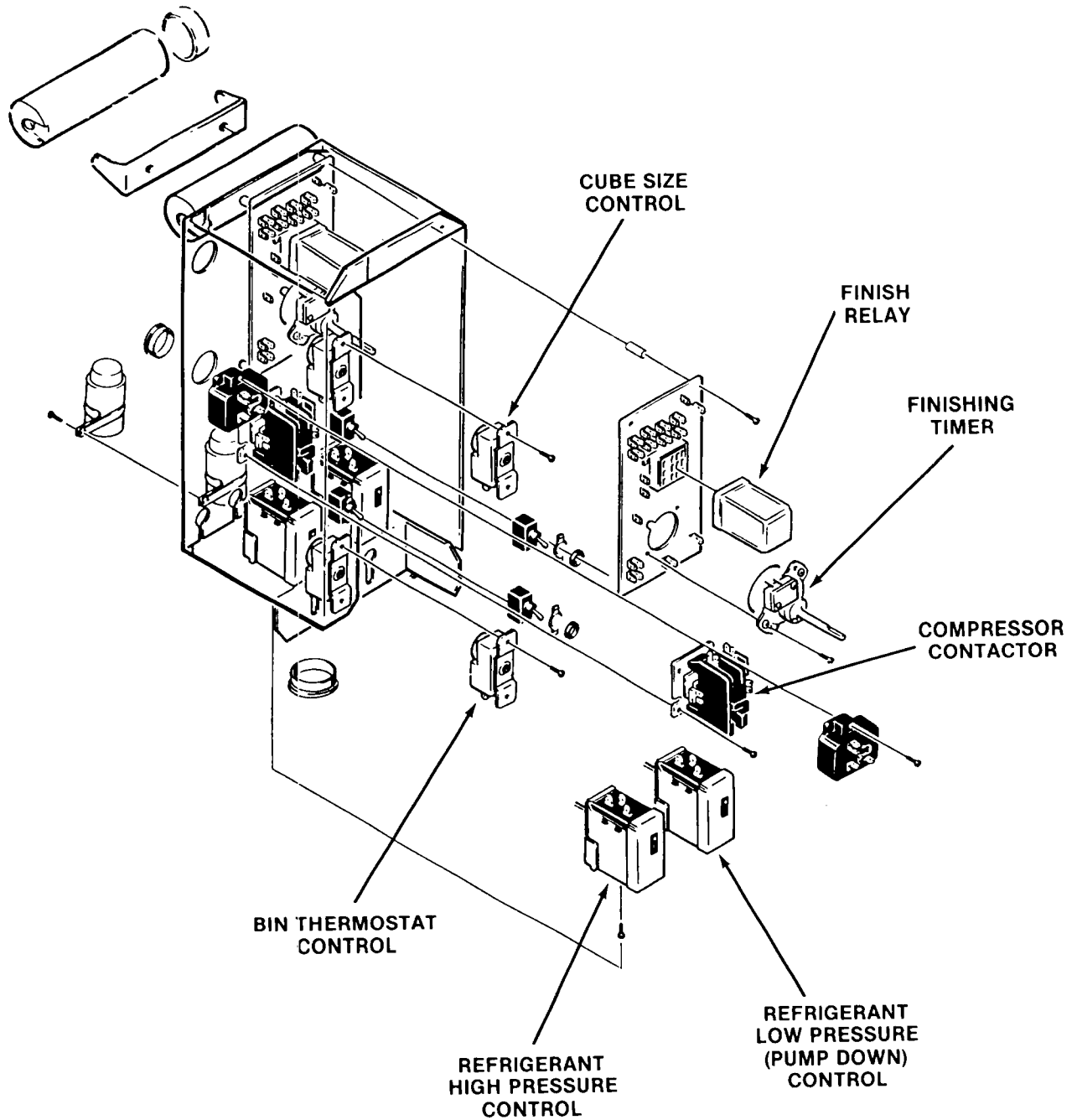

CM855R COMPONENT DESCRIPTION

BIN THERMOSTAT CONTROL

The bin thermostat control is located in the bottom of the control box. The sensing capillary tube of the control is routed from the control box through the inner left wall in the evaporator section to the bin thermostat control bracket hanging in the ice storage bin. The bin thermostat control functions to automatically shut OFF the icemaker when the ice storage bin is filled and ice contacts the capillary tube. It also signals the RESTART of the icemaker when the capillary tube starts to warm up after ice has been removed from the bin.

Bin thermostat control adjustment should ONLY be performed if premature shut off occurs or ice backs up into the freezing section of the cabinet. Adjust only in increments of one eighth turn of a screw at a time.

COMPRESSOR CONTACTOR

The compressor contactor functions to carry the compressor line current. The contactor is wired so any control in the pilot circuit such as the bin thermostat, low pressure and high pressure controls, etc., will cause the contactor holding coil to be de-energized when the control contact OPENS; thereby, breaking the circuit to the compressor through the contactor points.

REFRIGERANT HIGH PRESSURE CONTROL

The purpose of this safety control is to protect the unit from damage due to high refrigerant pressure. It also provides additional protection for the unit in high ambient temperatures. This is a manual reset control connected to the refrigeration system high-side. It is set to stop the unit completely when the high-side pressure reaches the preset limit.

REFRIGERANT LOW PRESSURE (PUMP DOWN) CONTROL

The purpose of this switch is to control the compressor. It keeps the compressor on to pump the refrigerant into the receiver after the liquid line solenoid has closed. It also provides additional protection for the unit in case low ambient temperatures exist. This is an automatic reset control connected to the refrigeration system low side. It is set to stop the compressor when the low-side pressure drops to less than 20 psig.

CUBE SIZE CONTROL

The temperature sensing cube size control affects the length of the freezing cycle prior to initiating the finishing timer. The cube size control closes its contacts when the evaporator reaches a preset temperature starting the finishing timer. A variation in either ambient air or incoming water temperature will affect the efficiency of the refrigeration system. This will vary the length of time it takes the evaporator to reach the temperature at which the cube size control is preset to CLOSE which, in turn, will affect the overall cycle time.

See *Cube Size Adjustment* BEFORE attempting to adjust the control.

FINISH RELAY

The multi-function, three pole, double-throw plug-in relay is installed directly into a receptacle on the printed circuit board in the control box. The relay functions, in part, to by-pass the bin thermostat control to prevent the icemaker from shutting OFF when a filled-bin condition occurs during the freezing cycle. The by-pass action serves to ensure full-sized cubes with each harvest cycle and to prevent short cycling on the bin thermostat control.

FINISHING TIMER — Timer & Switch Assembly.

The function of the finishing timer begins when activated by the cube size control. The outer surface, or large diameter lobe of the timer cam, determines the timer cycle for finish freezing of the ice cubes while the inner surface or small diameter lobe determines the time cycle for the harvest sequence. All electrical circuitry is connected through the printed circuit board and the finishing timer and double-throw microswitch. The microswitch is actuated by a cam assembly directly connected to the timer motor. The timer cam can be adjusted to vary the defrost time required.

CM855R SERVICE DIAGNOSIS

The service diagnosis section is for use in aiding the serviceman in diagnosing a particular problem for pin-pointing the area in which the problem lies, thus an ever available reference for proper corrective action.

The following chart lists corrective actions for the causes of known symptoms of certain problems that can occur in the icemaking-refrigeration system.

ICEMAKING - REFRIGERATION SYTSTEM

SYMPTOM	POSSIBLE CAUSE	CORRECTION
Irregular size cubes	Some distributor holes plugged.	Clean distributor holes. Clean water sump.
	Shortage of water.	See Shortage of water CORRECTION.
	Unit not level.	Level cabinet, as required.
Cubes too large.	Dirty air-cooled condenser.	Clean remote condenser.
	Cube Size Control set too cold.	Rotate Cube Size Control dial toward WARMER.
	Loss of refrigerant.	Check for refrigerant leaks, correct leaks; recharge system.
Cubes too small.	Cube Size Control set too warm.	Rotate Cube Size Control dial toward COLDER.
	Moisture in refrigeration system.	Blow refrigerant charge; replace drier; evacuate system; add proper refrigerant charge.
	Shortage of water.	See shortage of water CORRECTION.
	TXV valve super heat too high.	Replace valve.
Cloudy Cubes.	Shortage of water.	See Shortage of water SYMPTOM.
	Dirty water supply.	Install water filter or treatment system.
	Accumulated impurities.	Use SCOTSMAN Ice Machine Cleaner. See Cleaning Instructions.
Shortage of water.	Short harvest cycle.	Adjust cam of timer and switch assembly.
	Water leak in sump area.	Locate leak and correct condition.
	Partial restrictions in water strainer.	Clean or replace strainer.
	Low water pressure.	Check for incorrect supply line size or blockage. Check for low main pressure. If low, contact water company.

CM855R SERVICE DIAGNOSIS

SYMPTOM	POSSIBLE CAUSE	CORRECTION
Decreased Ice capacity.	High head pressure, result of dirty Condenser or Faulty Fan Motor.	Clean Remote Condenser Fins.
	Non-condensable gas in the system.	Repair or replace Fan Motor. Purge the system and recharge per nameplate requirements.
	Overcharge of refrigerant.	Slowly purge off to correct charge.
	Hot gas solenoid valve leaking.	Replace valve.
	Defective Compressor. Check amp draw of Compressor.	Replace Compressor.
	Leaky inlet water valve.	Replace valve.
	High Ambient temperature for condenser.	If possible, reduce condenser inlet air temperature.
Poor harvests. Icemaker does not harvest.	Too short defrost time.	Check and adjust harvest cycle.
	Restriction in water inlet line.	Check strainer and inlet water valve.
	Hot gas solenoid does not open. Binds or burned out.	Replace solenoid.
	Undercharge of refrigerant.	Charge to nameplate requirements.
	Water pressure too low.	Check for 20 PSI flowing water.
	Head Pressure Regulator valve - low head.	Replace valve.
Compressor cycles intermittently.	Low voltage.	Check for circuit overload. Check building supply voltage, if low, contact power company.
	Cycling on Low Pressure Control.	Cold Ambient at Condenser. Pump down Solenoid Coil Open. Replace it.
Unit Trips on Hi Pressure Cut Out.	Dirty Condenser.	Clean Condenser with vacuum cleaner or brush. DO NOT USE A WIRE BRUSH.
	Defective Fan Motor.	Replace Fan Motor.
	Non-condensable gases in system. Fan Relay of KCMR230 stuck.	Purge the system and recharge per nameplate requirements. Replace Relay.
Frost on Compressor.	TXV Metering too much Refrigerant.	Superheat set too low. Adjust or replace valve.

CM855R SERVICE DIAGNOSIS

SYMPTOM	POSSIBLE CAUSE	CORRECTION
Icemaker will not operate.	Blown fuse in line.	Replace fuse and check for cause.
	Master switch in OFF position.	Set switch to ON position.
	Faulty Master switch.	Replace switch.
	Timer contacts open.	Replace Timer.
	Improperly wired.	Contact electrical contactor for correction.
	Out of refrigerant, off on Low Pressure control.	Correct leak, recharge system
	High Pressure control tripped.	Reset, check condenser.
	Bin control open.	Check Bin Control Unit in coldroom or bin control defective.
Icemaker will not go into the Harvest Cycle automatically.	Liquid Line Solenoid valve not opening - keeps unit pumped down.	Repair or replace valve.
	Hi Temp Switch open.	Determine why Refrigerant Line is too hot.
	Cube size Control will not close.	Replace Size Control.
Water overflows from the sump into the bin.	Timer motor open.	Replace timer.
	Plug in relay contacts open.	Replace relay.
	Cube Size Control may not close if condensing pressure is too high.	Check condenser and discharge pressure.
Icemaker stays in the Harvest Cycle.	Restricted sump drain.	Repair drain.
	Inlet water valve lets in too much water.	Replace inlet valve.
Icemaker stays in the Harvest Cycle.	Plug in Relay Coil open.	Replace Relay.
	Timer Motor open or stuck.	Replace Timer.
	Timer Microswitch N.O. contacts will not close.	Replace Timer.

REFRIGERANT CHARGE DIAGNOSIS

On this model, the refrigerant charge is adequate whenever the sight glass remains full of liquid refrigerant throughout the Freeze Cycle. HOWEVER, the condensing temperature will have a direct bearing on this. A unit with a marginal charge in summer will be undercharged when the outside air temperature drops. The only correct and accurate way to charge this unit is to weigh in the nameplate charge.

CM855R REMOVAL AND REPLACEMENT PROCEDURES

WATER SYSTEM

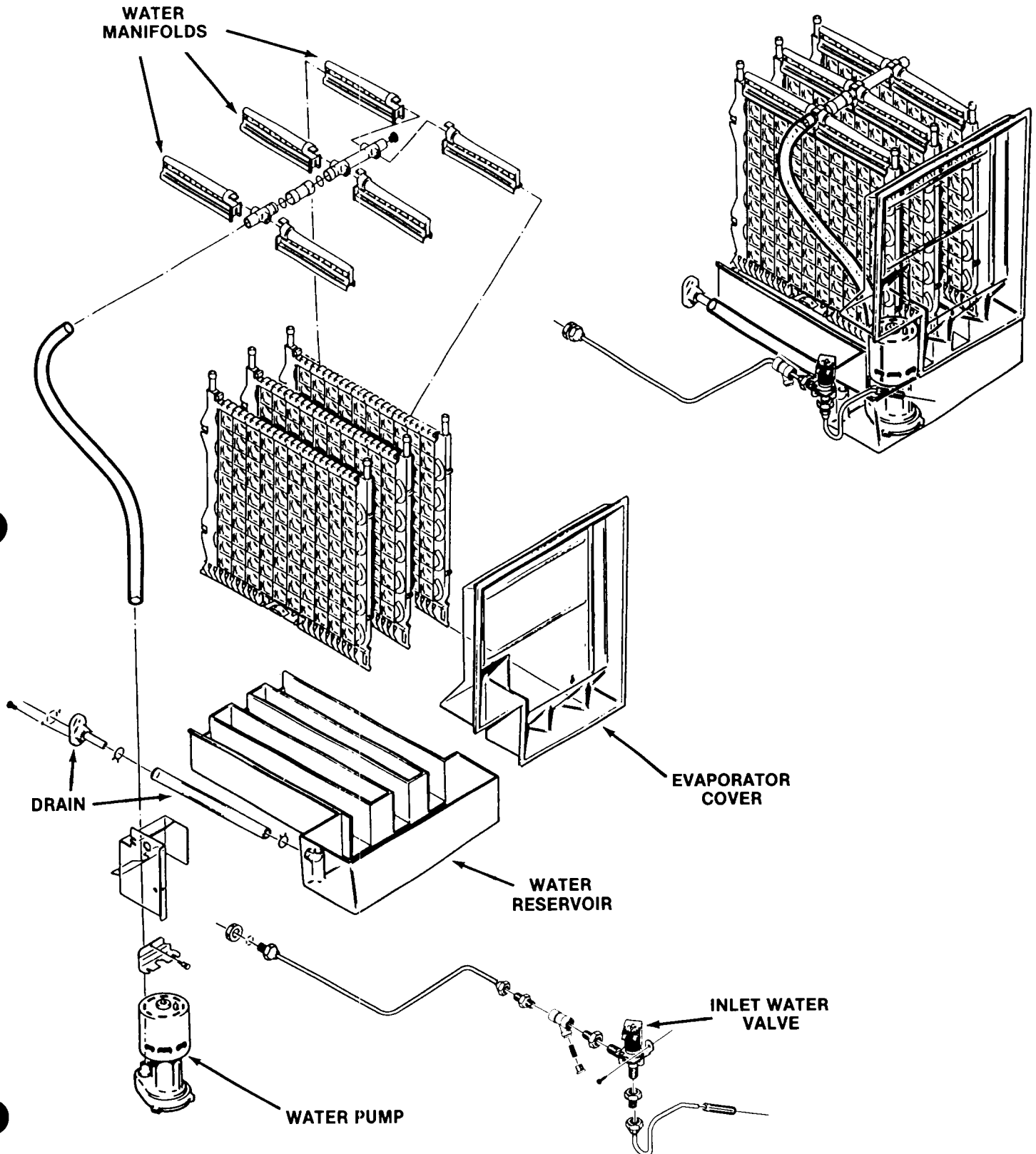

CM855R REMOVAL AND REPLACEMENT PROCEDURES

WATER PUMP

1. Remove front panel.
2. Lift up, and remove evaporator cover.
3. Unplug pump.
4. Remove one screw holding pump bracket to evaporator cross brace.
5. Pull pump forward and lift up.
6. Remove discharge hose from pump outlet.

Reverse to replace.

//////////////////// **WARNING** //////////////////////
Disconnect electrical power before beginning removal and replacement procedures.
////////////////////////////////////

RESERVOIR

1. Perform above steps and remove water pump.
2. Use corbin clamp pliers, push hose clamp of drain hose away from reservoir fitting. Remove drain hose from reservoir.
3. Lift up, and pull forward to remove reservoir.

Reverse to replace.

DISTRIBUTORS/WATER MANIFOLDS

1. Remove front panel.
2. Remove evaporator cover.
3. Pull distributor forward, and lift up in the back, after distributor comes up in back, push back and unsnap distributor from water manifolds.
4. Water manifolds can be pulled away from each other. Check "O" Rings in connectors.

Reverse to replace.

INLET WATER VALVE

1. Remove front panel.
2. Unplug water valve.
3. Remove flare nut securing outlet tube to valve.
4. Remove flare nut from inlet fitting.
5. Remove 2 screws securing valve to bulkhead wall, and remove valve.
6. Remove brass water fitting from old valve to put on new valve.

Reverse to replace.

CM855R REMOVAL AND REPLACEMENT PROCEDURES

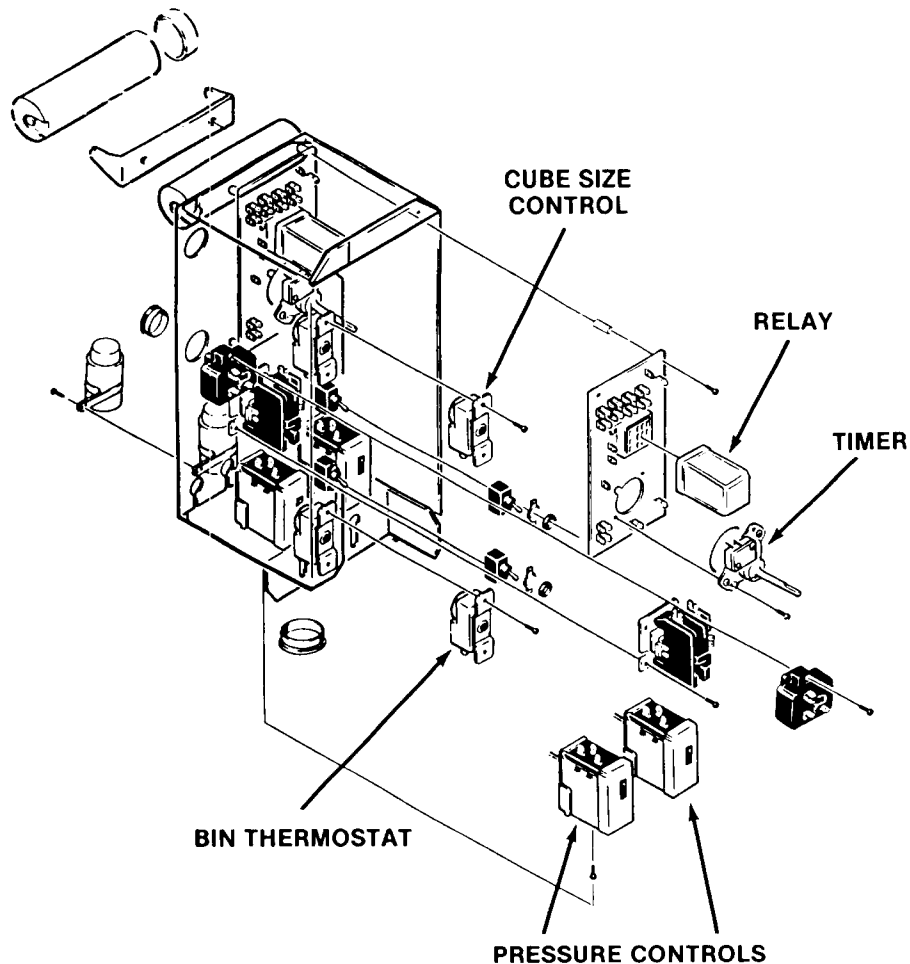

////////////////////// WARNING ////////////////////////

Disconnect electrical power before proceeding with any removal.

CUBE SIZE CONTROL

1. Remove front panel.
2. Remove control box cover.
3. Above and behind control box cover, locate the bulbwell for the cube size control, remove the insulation and the bulb.
4. Disconnect wires, remove knob, and the body of the control from the control box.

Reverse to reassemble.

TIMER

1. Remove front panel.
2. Remove control box cover.
3. Remove wires from P.C. board at posts marked "timer."
4. Unscrew two screws at timer from standoffs, and remove.

Reverse to reassemble.

BIN THERMOSTAT

1. Remove front panel.
2. Pull bin control capillary out of bracket.
3. Remove control box cover.
4. Disconnect wires from thermostat.

Remove two screws, and thermostat from control box.

Reverse to reassemble.

PRESSURE CONTROLS

These are connected to the refrigeration system, and therefore the skills of that trade are required to replace them.

1. Remove front panel.
2. Remove control box cover.
3. Disconnect wires at control.
4. Purge system of refrigerant.
5. Unswear control connection to refrigeration system, and remove control.
6. Reverse to reassemble, install new drier, evacuate and weigh in nameplate charge.

CM855R REMOVAL AND REPLACEMENT PROCEDURES

//////////////////// **WARNING** //////////////////////

Disconnect electrical power supply to icemaker whenever replacement procedures are performed.

////////////////////////////////////

COMPRESSOR

1. Remove top panel (if possible), front panel and left side service panel.
2. Disconnect electrical lines from compressor.
3. Purge system of refrigerant.
4. Remove compressor mounting bolts.
5. Cut or unsweat discharge, process, and suction lines.
6. Remove old filter drier.
7. Remove compressor from unit.

Check or replace starting components. Reverse steps to reassemble.

HOT GAS VALVE OR LIQUID LINE VALVE

1. Remove front, left side service panel, and top panel (if possible).
2. Unplug electrical connection to valve coil.
3. Purge system of refrigerant.
4. Cut out or unsweat valve, remove from machine.
5. To replace, heat sinking of the valve body is **critical**. Wrap the replacement valve in wet rags, and sweat it into place (make sure arrow on valve points in direction of refrigerant flow). Reverse steps 1-3 to reassemble.

THERMOSTATIC EXPANSION VALVE

1. Remove front and top panel (if possible).
2. Purge system of refrigerant.
3. Cut out or unsweat at inlet, equalizer, and outlet.
4. Remove insulation from valve bulb, remove mounting strap and valve from unit.
5. Place new valve bulb in the same place as the old, secure with straps, and reinsulate.
6. When replacing the valve, heat sinking or protecting the valve from damage is **critical**. Wrap the body of the valve in wet rags and sweat into place. Leave the rags on until the joints cool.
7. Remove and replace drier.

HEAD PRESSURE CONTROL VALVE

1. Remove left side service panel.
2. Purge the system of refrigerant.
3. Cut out or unsweat valve.
4. Wrap the new valve in wet rags to prevent damage from heat, and sweat into place.
5. Remove and replace drier.

NOTE

*Always install a replacement drier, any time the sealed refrigeration system is opened. Do not replace the drier until all other repair or replacement has been completed. Evacuate and **WEIGH IN** the nameplate charge.*

CM855R REMOVAL AND REPLACEMENT PROCEDURES

REMOVAL AND REPLACEMENT OF THE EVAPORATOR PLATE ASSEMBLY

1. Remove the front and top panels.
2. Bleed off or blow the refrigerant charge through the Schrader valve.
3. Disconnect Tygon water inlet tube(s), at the water manifold tee(s), above the evaporator plates.
4. Remove reservoir and pump.
5. Slide the water distributor tubes about 1/8-inch along the top of the evaporator plate to be removed, until the left water distributor tube can be lifted upward.
6. Lift the end of the water distributor tube and slide the distributors toward the left along the top of the evaporator plate, until the flexible right notch is cleared.
7. Unsnap and disconnect each left and right water distributor tube from the water manifold section.

//////////////////// CAUTION //////////////////////

Use **EXTRA PRECAUTION** to protect the plastic parts during the next step to unsolder the refrigerant lines, two places, at the top of the evaporator plate. Position wet cloths over top of plates, as well as over the plastic liner at the rear or sides, to prevent accidental heat damage or possible fire from torch flame.

////////////////////////////////////

8. Unsolder and remove the refrigerant lines at the top of the evaporator plate to be replaced.
9. Loosen the braces just enough to remove the evaporator plate. Temporarily replace the braces to support the remaining evaporator plate(s).

Always install a replacement drier, anytime the sealed refrigeration system is opened. Do not replace the drier until all other repair or replacement has been completed.

To replace the evaporator plate, reverse the removal procedures. See Nameplate. Weigh in proper charge of R-502.

Whenever a new charge of refrigerant is placed in the system, the compressor should **NOT BE RUN** until the crankcase heater has been on for 12 hours after re-charging.

CHARGING PROCEDURES

Particular care must be taken when recharging this remote system. No liquid refrigerant may be placed in the system at the compressor. **DO NOT** use the Schrader valves at the front of the machine for weighing in the charge. All liquid R-502 must be weighed into the receiver through the "front seated" King Valve.

