

TABLE OF CONTENTS

Table of Contents	i
List of Illustrations	iii
Specifications	iv
SECTION I- GENERAL INFORMATION & INSTALLATION	1-1
I. Introduction	1-1
II. Unpacking and Inspection	1-1
III. Location and Leveling	1-2
IV. Electrical Connections	1-2
V. Water Supply and Drain Connections	1-2
VI. Final Check List	1-3
SECTION II- START UP OPERATION	2-1
I. Start Up	2-1
SECTION III- PRINCIPLES OF OPERATION - How it Works	3-1
I. Icemaker	3-1
II. Electrical/Refrigeration	3-2
SECTION IV- ADJUSTMENT AND REMOVAL AND REPLACEMENT PROCEDURES	4-1
I. Adjustment of the Bin Thermostat Control	4-1
II. Adjustment of the Leg Levelers	4-2
III. Adjustment of the Water Reservoir Float	4-2
IV. Removal & Replacement of the Auger, Water Seal, Bearings and Coupling	4-2
V. Removal & Replacement of the Compressor Assembly	4-3
VI. Removal & Replacement of the Condenser - Air Cooled Models	4-3
VII. Removal & Replacement of the Drier	4-4
VIII. Removal & Replacement of the Drivemotor Assembly	4-4
IX. Removal & Replacement of the Fan Motor Assembly - Air-Cooled Models	4-4
X. Removal & Replacement of the Freezer Assembly	4-4

TABLE OF CONTENTS (Cont'd)

XI.	Removal & Replacement of the Spout Assembly	4-5
XII.	Removal & Replacement of the Water Pressure Control	4-6
XIII.	Removal & Replacement of the Water Reservoir Assembly.....	4-6
SECTION V-	MAINTENANCE & CLEANING INSTRUCTIONS	5-1
I.	General.....	5-1
II.	Icemaker.....	5-1
III.	CLEANING - Icemaker	5-2
SECTION VI-	SERVICE DIAGNOSIS	6-1
I.	Icemaking - Refrigeration System	6-1
SECTION VII-	WIRING DIAGRAMS	7-1
	Wiring Diagram AF-330 Air-Cooled Model.....	7-2
SECTION VIII -	THE PARTS ILLUSTRATIONS AND PARTS LISTS	8-1
I.	General.....	8-1
II.	How to Use the Illustrations and Parts Lists	8-1
III.	How to Order Parts or Assemblies	8-1

LIST OF ILLUSTRATIONS

	Specifications - Model AF-330	iv
Figure 1-1.	Installation Practice	1-4
Figure 2-1.	Water Schematic	2-1
Figure 3-1.	Refrigeration Cycle	3-1
Figure 4-1.	Adjustment of the Temperature Control	4-1
Figure 4-2.	Removal of the Freezer Assembly	4-6
Figure 4-3.	Removal of the Spout Assembly	4-6
Figure 4-4.	Removal of the Water Reservoir Assembly	4-7
Figure 7-1.	Wiring Diagram - AF-330 Air-Cooled	7-2
Figure 8-A.	Automatic Flaker AF-330 Flow Chart	8-2
Figure 8-1.	AF-330 Cabinet	8-3
Figure 8-2.	Major Assemblies - Air-Cooled	8-7
Figure 8-3.	Compressor Assembly	8-12
Figure 8-4.	Spout Assembly	8-13
Figure 8-5.	Freezer Assembly	8-15
Figure 8-6.	Drivemotor Assembly	8-18
Figure 8-7.	Control Box Assembly	8-22
Figure 8-00.	How to Use the Illustrated Parts List	8-24



This icemaker has been engineered to our own rigid safety and performance standards. The National Sanitation Foundation (NSF) seal, signifies that it is listed with the NSF and that it complies with the materials and construction standards of the NSF. In addition, the Underwriters Laboratories, Inc., (UL) Listing Mark and the Canadian Standards Association (CSA) Monogram, both signify that its construction and design have been inspected and tested by them. NSF, UL and CSA inspectors also periodically examine production icemakers at the factory, to assure continued compliance.

To retain the safety and performance built into this icemaker, it is important that installation and maintenance be conducted in the manner outlined in this manual.

SPECIFICATIONS

MODEL AF330

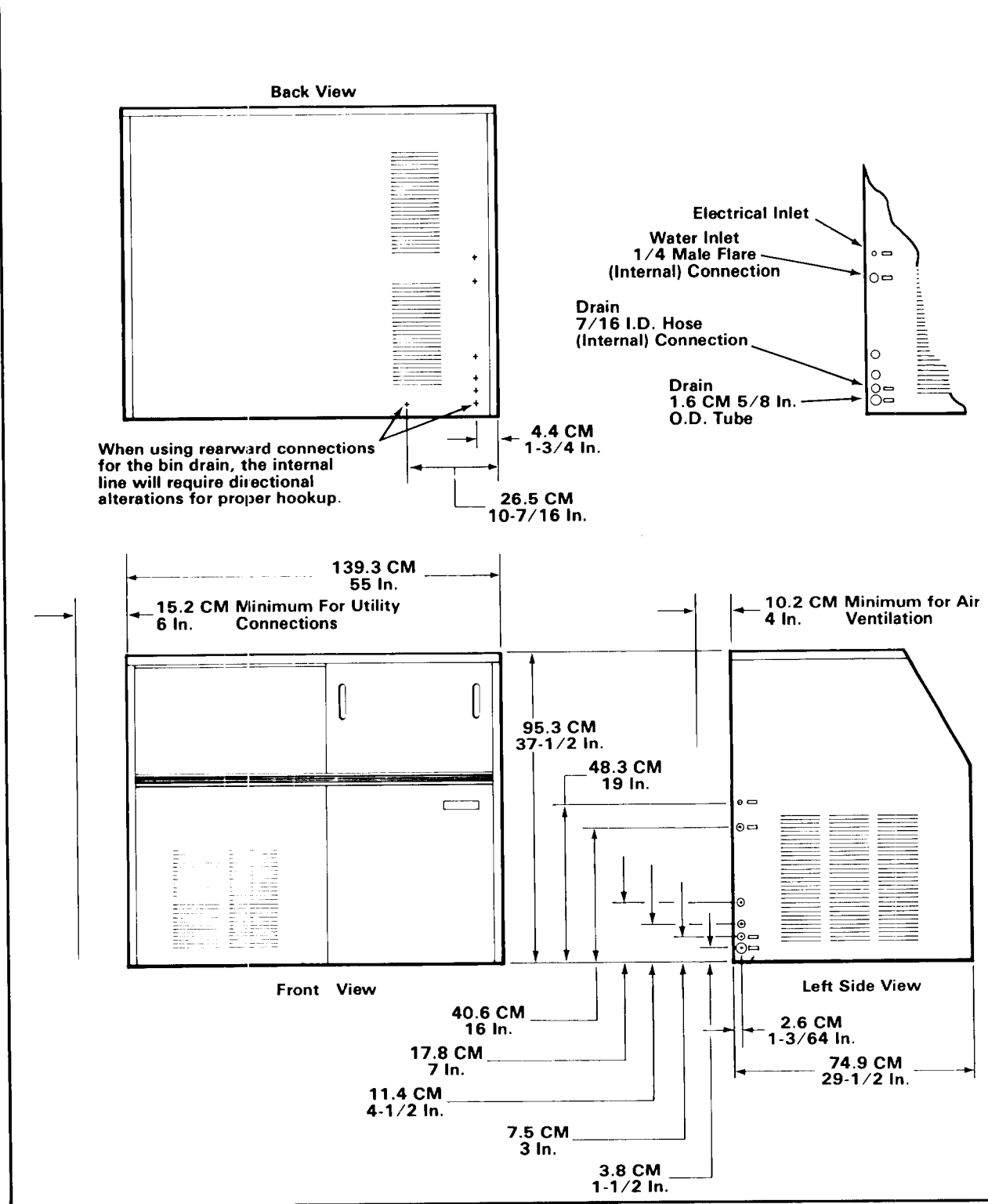

SPECIFICATIONS (Cont'd)

MODEL AF-330

Bin Storage: 377 lbs.*

Air-Cooled: Model AF-330 1A

Electrical: 115/60/1

Est. Ship. Wt.: 350 lbs.

TWO YEARS PARTS WARRANTY

FRONT SERVICE ACCESS PANEL

OPTIONAL LEG KIT

KLP2E - 6-inch metal legs, Black Enamel

KLP2S - 6-inch metal legs, Nickel Plated

OPTIONAL PANEL KIT

SPKAF30 - Stainless Panel Kit

MODEL NUMBER		MOTORS	VOLTS	HP/WATT	F.L.A.	L.R.A.
SERIAL NUMBER		COMP.				
		DRIVE				
REFRIGERANT 12	HEATER	FAN				
OZ	WATTS	OTHER				
TEST PRESSURE 140 LO - 235 HI						
A.C. SUPPLY VOLTAGE			WIRES	CYCLES	PHASE	
MAXIMUM FUSE SIZE	AMPS	MINIMUM CIRCUIT AMPACITY				
QUEEN PRODUCTS DIVISION KING-SEELEY KT THERMOS CO ALBERT LEA, MINNESOTA U.S.A.						

SEE NAMEPLATE for electrical and refrigeration specifications. NAMEPLATE located on rear service panel, near left rear corner of the cabinet. Shown in column at left.

Remove Lower Left Front Panel to locate the Model/Serial Number plate, shown below, on the Chassis frame under the Control Box Cover.

MODEL NUMBER	QUEEN PRODUCTS DIVISION
	KING-SEELEY KT THERMOS CO.
	ALBERT LEA, MINNESOTA U.S.A.
SERIAL NUMBER	

*Storage based on 90-percent of total volume x 34 lb. average density of ice. A.R.I. Standard.

We reserve the right to make product improvements at any time. Specifications and design are subject to change without notice.

SECTION I

GENERAL INFORMATION & INSTALLATION

I. INTRODUCTION

This manual provides the specifications and the step-by-step procedures for the installation, start-up and operation, and the maintenance and cleaning for the SCOTSMAN Model AF-330 Automatic Flakers.

The Model AF-330 Automatic Flakers are quality designed, engineered and constructed, and thoroughly tested icemaking and ice storage systems, providing the utmost in flexibility to fit the needs of a particular user. Separate sections detail more specifically: General Information & Installation; Start Up Operation; Principles of Operation; Adjustment and Removal and Replacement Procedures; Maintenance and Cleaning Instructions; Service Diagnosis; Wiring Diagrams; and, the Illustrated Assemblies and Parts Lists.

One of the outstanding features of this series of Flakers, is the easy access for service. With the front of the cabinet removed, the entire refrigeration system can be removed from the cabinet for on-the-spot repair. When it might become necessary to return the system to the shop, a second unit may be installed in a very short time, so the customer is not without ice. The repaired unit can be re-installed in a matter of minutes.

DESCRIPTION

An attractive compact cabinet of textured metal with a Sandalwood enamel finish, a wood-grain upper left front panel, and a bin access door. Also, an optional stainless steel cabinet finish is available. Both cabinets have up-to-date styling, and easily removable panels for easy access to electrical and mechanical components.

SEALED REFRIGERATION SYSTEM

To provide quiet efficient operation of the Ice-maker, the Compressor motor is internally spring-mounted. The Compressor motor is covered by a five year parts warranty. The Freezer Assembly is powered by a direct-drive, gear motor, Drivemotor Assembly.

SELF-CONTAINED STORAGE BIN

These Automatic Flakers store their own ice supply in a heavily insulated ice storage bin, with a sliding Ice Access Door opening the front of the cabinet.

STANDARD OVERALL DIMENSIONS

The standard overall dimensions of the cabinet depth, counter top height, etc., allows the Automatic Flaker to be installed in harmony with the existing counter equipment.

II. UNPACKING AND INSPECTION

1. Call your authorized SCOTSMAN Distributor or Dealer, for proper installation. He's listed under ICE MAKING EQUIPMENT and MACHINERY in the yellow pages of the telephone book.
2. Visually inspect the exterior of the shipping container and skid and any severe damage noted, should be reported to the delivering carrier; and, a concealed damage claim filed subject to internal inspection, with carrier representative present.
3. BEFORE removal of any panels or packing, carefully lay the cabinet on its back and remove the shipping bolts and the shipping base or skid.
4. When ordered, install the optional leg levelers in the cabinet base sockets; then, raise the cabinet to the upright position.
5. Remove screws and shipping tape, and all doors and service panels from the cabinet, and inspect for any concealed damage. Notify carrier of any concealed damage claims, as stated in step 2 above.
6. Remove all internal support packing, tape and wires in machinery compartment.
7. Check that refrigerant lines do not rub or touch lines or other surfaces, and that fan blades, if any, move freely.
8. Check that the Compressor is snug on all mounting pads.
9. Remove Water Strainer from shipping envelope, for installation in water supply line.
10. Use clean damp cloth or disposable paper wiper to wipe clean the interior surfaces of the ice storage Bin and the exterior surfaces of the cabinet.
11. See NAMEPLATE on the rear service panel, near the left rear corner of the cabinet and

check that the location source voltage corresponds with the voltage specified on the nameplate.

CAUTION

Improper voltage supplied to the Icemaker will void your parts replacement program.

12. Remove the Manufacturer's Registration card from the front of the User's Manual and fill in all spaces including; Model Number and Serial Number taken from the aluminum plate located on the Chassis frame, under the Control Box Cover. Forward the completed, self addressed, registration card to the SCOTSMAN Factory.

III. LOCATION AND LEVELING

WARNING

This Automatic Flaker is NOT designed for outdoor installations where air temperatures are below 50-degrees F., or above 100-degrees F., and the water temperature is below 40-degrees F. or above 100-degrees F. Extended periods of operation at temperatures exceeding these limitations will constitute misuse, under the terms of the SCOTSMAN Manufacturer's limited warranty, resulting in LOSS of warranty coverage.

1. Tilt the Cabinet forward from the rear and safely position support blocks in place, for work access to bottom of the Cabinet.
2. Locate and remove the single Hex-Hd Shipping Screw, Washer and Lockwasher, used to secure the rear of the Chassis base during shipment from the factory. Remove support blocks and lower rear of Cabinet.

NOTE

Retain shipping hardware removed in this step and be sure to re-install the Screw and Washers before transporting the Flaker to a different location.

NOTE

Prior consideration for location site shall include:

1. *Minimum room temperature 50-degrees F. and maximum room temperature 100-degrees F.*
2. *Water inlet temperatures: Minimum 40-degrees F. and Maximum 100-degrees F.*
3. *Well ventilated location for Air-Cooled model, advising user to frequently clean Condenser, located directly behind left front service door.*
4. **SERVICE ACCESS:** *Adequate space for all service connections, through the rear of the*

Cabinet. A six-inch minimum clearance at rear, left and front louvered panels, for routing cooling air drawn into and exhausted out of the compartment, to maintain proper condensing operation on Air-Cooled models.

3. Level the Cabinet in both the left-to-right and front-to-rear directions. The optional leveling legs can be adjusted with an open-end wrench.

IV. ELECTRICAL CONNECTIONS

SEE NAMEPLATE for current requirements to determine wire size to be used for electrical hookup. The Automatic Flaker requires a solid earth ground wire. See wiring diagram.

Be certain the Automatic Flaker is connected to its own electrical circuit and individually fused. The maximum allowable voltage variation should not exceed ten percent of the nameplate rating, even under starting conditions. Low voltages can cause erratic operation and may be responsible for serious damage to the overload switch and motor windings.

All external wiring should conform to the National, State and local electrical code requirements. Usually an electrical permit and service of a licensed electrician will be required.

V. WATER SUPPLY AND DRAIN CONNECTIONS

A. WATER CONNECTIONS: The recommended water supply line is a 1/4-inch O.D. copper tubing. Connect to cold water supply line with standard plumbing fittings, with a shutoff valve installed in an accessible place between the water supply and the Cabinet.

A wire mesh strainer is provided and must be installed with the cleanout plug down. Locate the strainer in the water supply line, next to the Cabinet with the arrow on the strainer, in the direction of the water flow. The strainer protects against large particles of rust, scale, etc., which may be loosened in the water supply pipe, at the time of installation.

In some cases, a plumbing permit and services of a licensed plumber will be required.

WARNING

To prevent damage to the freezer mechanism, DO NOT operate this unit when the water supply is OFF, or is below 20 PSI, the recommended water pressure. Position the master switch to the OFF position, until proper water supply is resumed.

The Icemaker in this Cabinet will not operate when water supply temperatures are below 40-degrees F. or above 100-degrees F.

B. DRAIN CONNECTIONS: All drains are gravity type and must be 1/4-inch per foot on horizontal run. The drains to be installed to conform with local code. The drain receptacle should be an open, trapped or vented construction. See Figure 1-1.

Recommended Bin Drain is 5/8-inch O.D. copper tubing, should be vented and run separately. Connect a drain line to 7/16-inch I.D. tube from the Reservoir Overflow.

WARNING

This Automatic Flaker will NOT operate when water supply temperature is below 40-degrees F., or above 100-degrees F. Requires 20 PSI flowing water pressure, without interruption.

VI. FINAL CHECK LIST

1. Has the single Hex-Hd Shipping Screw, for rear Chassis base, been removed.
2. Is the Cabinet level? (IMPORTANT)
3. Have all electrical and piping connections been made?
4. Has the voltage been tested and checked against the nameplate rating?
5. Is the water supply line shutoff valve installed and electrical wiring properly connected?
6. Have the Bin and Cabinet been wiped clean?
7. Have the Compressor hold down nuts been checked, to be sure the Compressor is snug on the mounting pads?
8. Has the owner/user been given the User Manual and instructed on how to operate the Icemaker?
9. Has the Manufacturer's Registration Card been properly filled out? Check for correct Model and Serial numbers from the Serial nameplate, then mail the completed card to the SCOTSMAN factory.
10. Check all refrigerant lines and conduit lines, to guard against vibration or rubbing and possible failure.
11. Is there at least six inches clearance behind and around Cabinet for proper air circulation?
12. Is the Cabinet in a room where ambient temperatures are a minimum of 50-degrees F. all year around?
13. Has water supply pressure been checked to insure a minimum of 20 PSI?
14. Has the owner been given name and telephone number of the authorized SCOTSMAN Service Agency serving him?

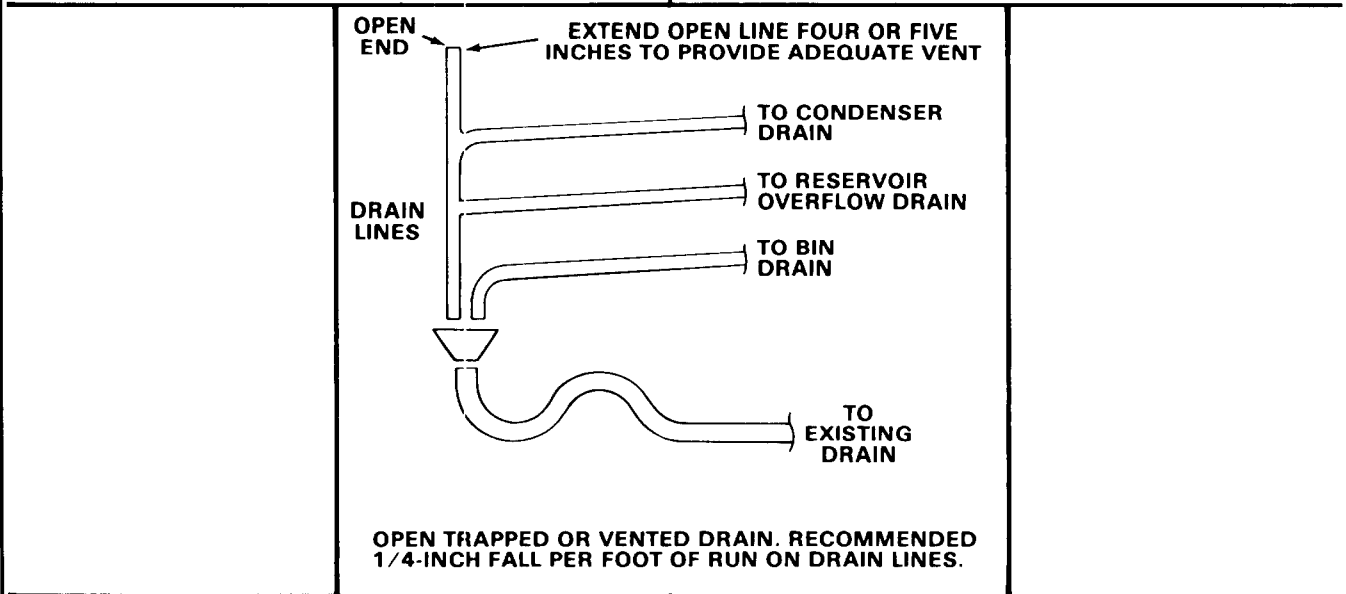
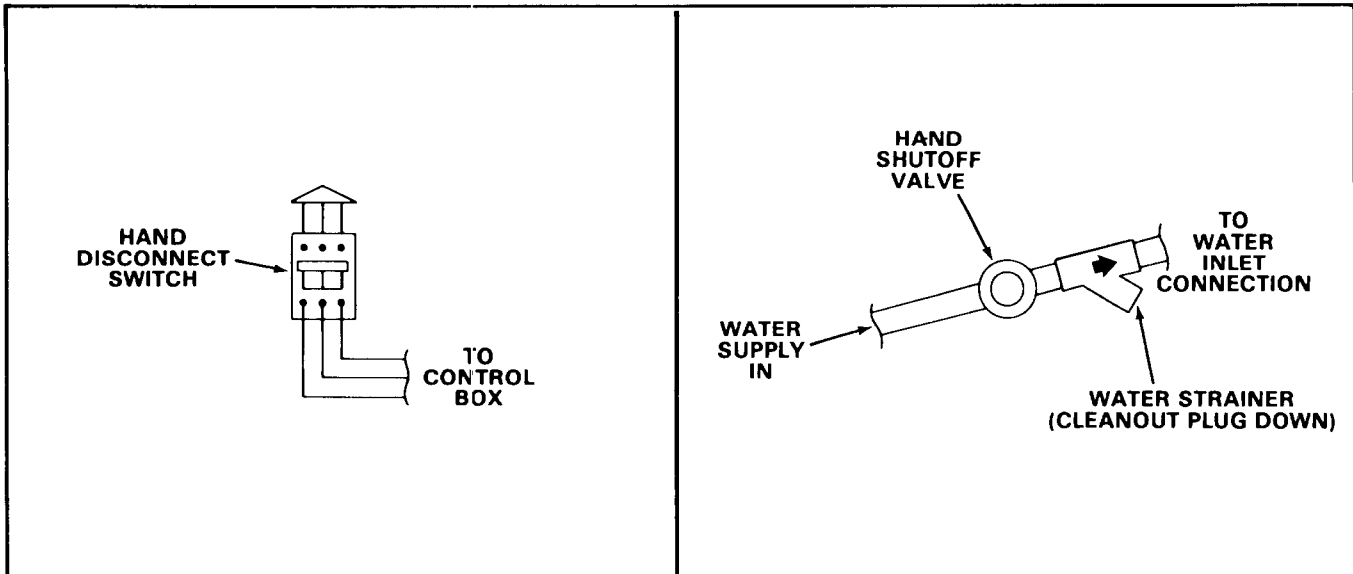

WARNING

THIS ICEMAKER IS NOT DESIGNED FOR OUTSIDE INSTALLATION AND WILL NOT OPERATE IN AMBIENT TEMPERATURES BELOW 50-DEGREES F., NOR ABOVE 100-DEGREES F.

THIS ICEMAKER WILL NOT OPERATE WHEN WATER TEMPERATURES ARE BELOW 40-DEGREES F., NOR ABOVE 100-DEGREES F.

Figure 1-1. Installation Practice

SECTION II OPERATING INSTRUCTIONS

I. START UP

1. Remove screws and the Lower Left Front Panel and the Left Side Panel.
2. OPEN the water supply line shutoff valve.
3. Observe the water filling operation, see Figure 2-1:
 - a. Water flows into Water Reservoir.
 - b. Float moves up as water rises.
 - c. Water flows through water feed line to bottom of Freezer Assembly.
 - d. Float stops water flow, when water level reaches 3/8-inches below the molded horizontal line, on the body of the Water Reservoir.
4. Move the manual ON-OFF toggle switch, on top of the Control Box to the ON position, to

start the automatic icemaker operation.

5. After two or three minutes of operation, observe that flaked ice begins dropping off the Auger and out the Ice Spout, through the Nylobraid tubing and into the Ice Storage Bin.
6. Let the system operate for about 30 minutes or until ice covers the bottom of the Bin. Check for any excess noises beyond normal Compressor noise:
 - a. Fan noises, when Air-Cooled: Blades touch other surfaces; blades bent, out-of-balance.
 - b. Vibrating type from touching lines.
 - c. Chattering: Lack of water in Freezer.
 - d. Compressor loose at one or more hold-down bolts.

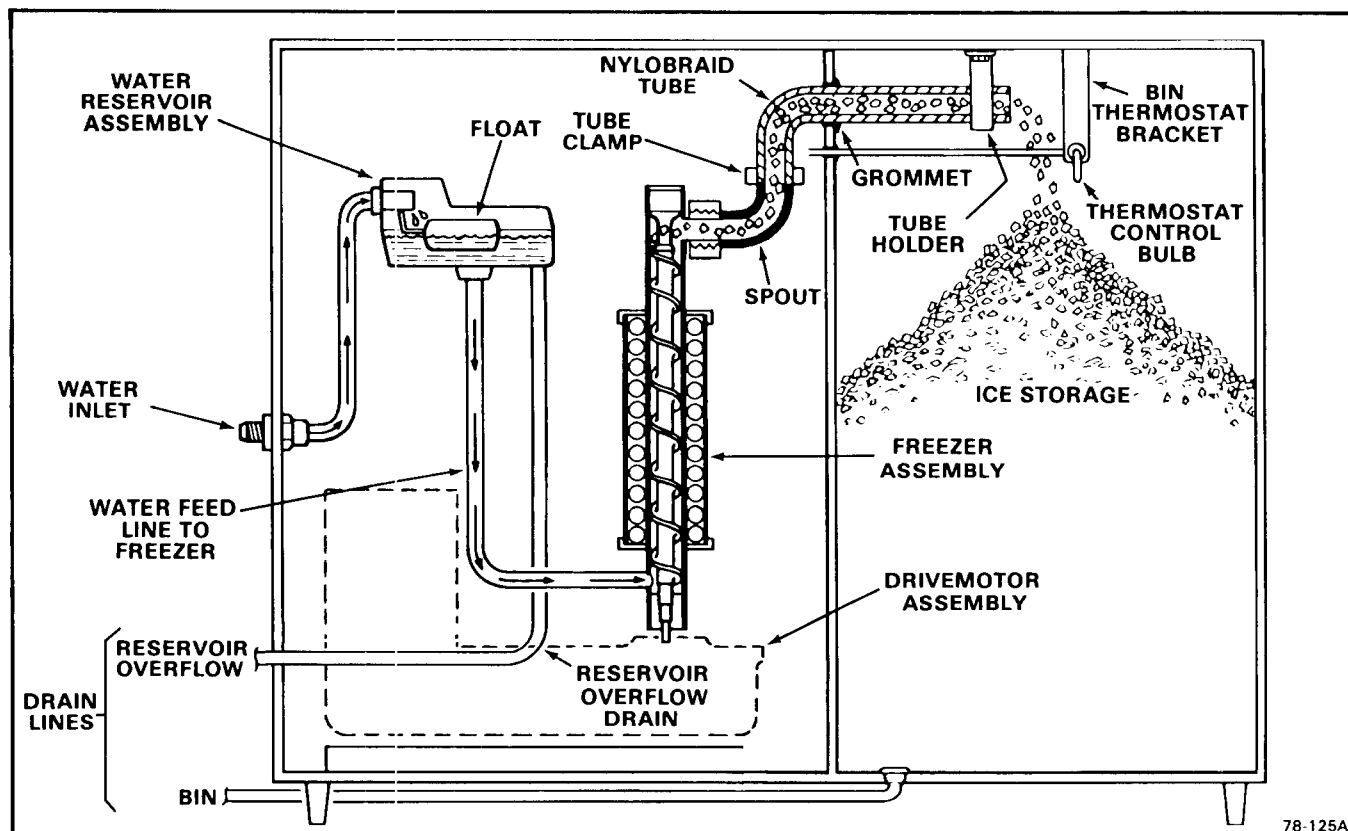

Figure 2-1. Water Schematic

WARNING

DO NOT operate this Icemaker when the water supply is shut OFF, or is BELOW the recommended 20 PSI water pressure. Move the manual ON-OFF toggle switch on the front of the Control Box to the OFF position immediately.

7. Hold a handful of ice around the Ice Storage Bin Thermostat Control Bulb to test shut-off. Less than one minute is about normal for Bulb shutoff function to cause the Compressor to stop.

NOTE

Within minutes after the ice is removed from the sensing bulb, the bulb will warm up and cause the Icemaker to restart. This control is factory set and should not be reset until testing is performed. Normal setting: about 35-degrees F. CUT-OUT and 45-degrees F. CUT-IN, to prevent short cycling.

8. Thoroughly explain to the owner/user the significant specifications of the Icemaker, the start up and operation, going through the procedures in the operating instructions. Answer all questions about the Icemaker, by the owner; and, inform the owner of the name and telephone number of the authorized SCOTSMAN Service Agency serving him.

SECTION III

PRINCIPLES OF OPERATION

How It Works

I. ICEMAKER

The water supply flows from the building source through the inline water strainer, enters at the Cabinet fitting and on to the Water Reservoir. The Water Reservoir functions to maintain a constant water level inside the Freezer Assembly. Water from the Water Reservoir enters at the bottom of the Freezer Assembly and is changed into ice by low temperatures inside the Freezer.

A stainless steel Auger within the Freezer is powered by the Drivemotor Assembly, a direct-drive gearmotor, and the rotating Auger carries the ice upward to the flared end of the Auger, see Figure 3-1, where excess water is pressed out of the ice, as it is extruded or flaked out through the Ice Spout, through the Nylobraid tubing and into the Ice Storage Bin.

Moving the manual ON-OFF toggle switch, on the top of the Control Box, to the ON position starts the automatic and continuous icemaking process. When the Ice Storage Bin has been filled with ice, up to the level of the Thermostat Control Bulb, the sensing bulb shuts off the icemaking process.

As the ice is removed from the Ice Storage Bin, the Thermostat Control Bulb warms up, restarting the automatic icemaking process.

Factory settings are 35-degrees F. CUT-OUT and 45-degrees F. CUT-IN.

Altitude adjustment should ONLY be performed on Icemakers installed at 2000-foot level locations and ABOVE, and adjust only in increments of one-fourth turn of screw at a time.

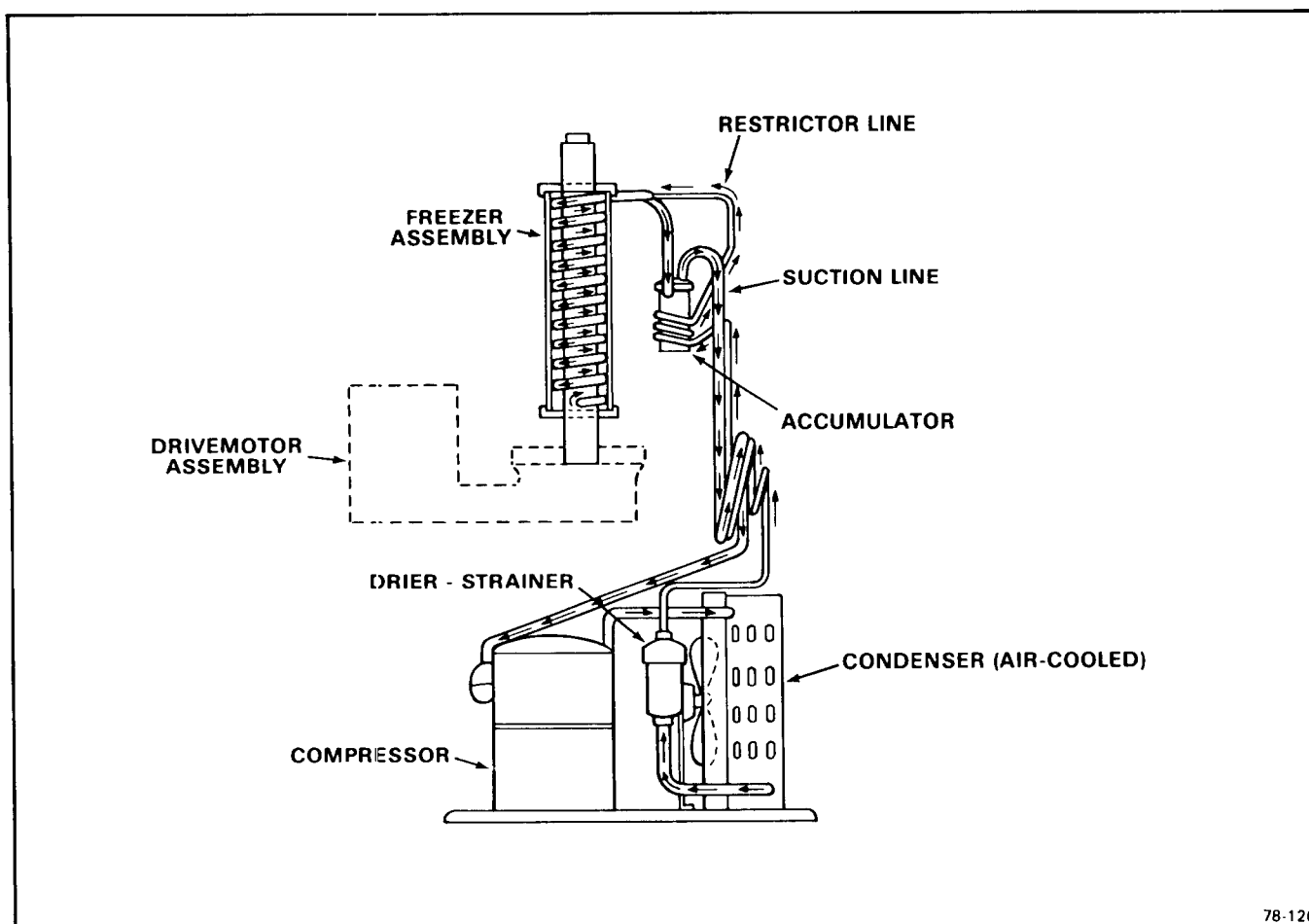

Figure 3-1. Refrigeration Cycle

II. ELECTRICAL/REFRIGERATION

The AF-330 Automatic Icemakers are designed to operate on standard electrical supply 115 volts, 60 Hertz, single phase. Other voltage requirements are available on special order. Therefore, always CHECK NAMEPLATE for electrical information BEFORE proceeding with electrical wiring connections to the Icemaker.

Cold ambient temperatures and interruptions in water supply are conditions that can cause excessively hard ice and overloads within the Freezer Assembly, which is directly transmitted to the Drivemotor; and in turn, will cause speed reduction or ultimate freezeup.

When the Drivemotor is slowed to a pre-determined RPM, a sensing switch mounted on top of the motor is designed to open the electrical circuit to the Compressor. The Compressor stops operating, no more ice is produced, and the Drivemotor continues to operate rotating the Auger to clear the overload and gradually build up to full speed.

At a pre-determined higher RPM Drivemotor speed, the speed sensing switch closes the electrical circuit to the Compressor, causing the normal icemaking process to resume. Refer to specific details in paragraph V-II-9, on centrifugal sensing switch operation.

A Spout Switch is mounted on the side of the Ice Spout and is actuated by the movement of the spring retained spout tube against the switch actuator. The Spout Switch acts as a backup safety switch, should the Thermostat Control Bulb fail and cause ice to jam up in the Ice Spout. The switch will shut off the icemaker only when actuated. It is an immediate and complete shut down of the entire icemaker. The Spout Switch can be manually tested, by plugging the end of the Nylobraid Tube. The switch is also manually reset.

There are two safety controls in the Control Box. The Low Pressure Control, a manual reset, non-adjustable control, is set to electrically open at zero to four PSIG to stop the entire icemaker. The Auger Delay Switch, a single-pole double-throw (SPDT) switch, functions as a control device to allow the gearmotor to rotate the Auger to clear the Freezing Chamber while the compressor circuit is OFF.

Refer to the appropriate Wiring Diagram and trace circuitry and control functions, as described in the following paragraph.

As shown on all SCOTSMAN wiring diagrams, the controls are the ICEMAKING MODE.

Thus, the 1-2 contacts are CLOSED. At STARTUP, the 1-2 contacts are OPEN and the 3-2 contacts are CLOSED. As the icemaker begins to operate, the low side pressure starts to decrease from the stabilized or at-rest pressure. As soon as the pressure is reduced to 20 PSIG, the 3-2 contacts OPEN and the 1-2 contacts CLOSE.

This removes the operating controls, such as the Bin Thermostat, from the gearmotor circuit. If one of the operating controls OPENS, it will SHUT OFF the compressor circuit. The gearmotor will operate until the low side pressure increases to 32 PSIG. Then, the 1-2 contacts OPEN and SHUTS OFF the gearmotor, usually within one to two minutes, depending upon ambient conditions. This brief period of time allows the Auger to transport all the ice out of the Freezing Chamber. Consequently, when called on to STARTUP again, there is no ice load to start up against. Again, on STARTUP, the 1-2 contacts are OPEN and the 3-2 contacts are CLOSED.

On all models, a low-water pressure switch functions to discontinue the Icemaking process whenever incoming water pressure is reduced to below five PSIG. The Switch will automatically restart the Icemaking process when the water pressure is increased to 20 PSIG.

The head pressure is normal about 130 PSIG, however, it will vary depending upon ambient air temperature.

Suction pressure should be 15 PSIG with proper refrigerant charge and the frost line should extend out from the Accumulator to within no closer than eight to twelve inches of the Compressor. Suction pressure will vary about two PSIG plus or minus, depending upon ambient temperatures and incoming water supply temperatures to the Freezer Assembly.

When charging the system with refrigerant, always CHECK NAMEPLATE for specific refrigeration charge for individual Flaker, and charge with refrigerant so the frost line extends out of the Accumulator to within no closer than eight to twelve inches of the Compressor, after 15 minutes of operation, for best capacity and performance.

MODEL	AF330 Refrig. Chg.
Air-Cooled	22 oz. R-12 (Approx.)

SECTION IV

ADJUSTMENT AND REMOVAL AND REPLACEMENT

The procedures provided in this Section are arranged in alphabetical order, to make specific Adjustment and Removal and Replacement information easy to locate.

Read the instructions thoroughly before performing any Adjustment or Removal and Replacement Procedures.

I. ADJUSTMENT OF THE BIN THERMOSTAT CONTROL

The control for the Bin Thermostat is the Temperature Control, located on the upper part of the Control Box Assembly.

See Figure 4-1 for location and direction of rotation, clockwise (CW) or counterclockwise

WARNING

The adjusting screws on the Temperature Control device have very sensitive response to adjustment. **DO NOT** attempt to adjust the screw until after thoroughly reading and understanding the following instructions and illustrations. Over-adjusting or erratic guessing, can foul the instrument and cause ultimate delay and part replacement, **WHICH COULD HAVE BEEN PREVENTED.**

(CCW), of the adjusting screws on the Temperature Control, in the particular Control Box the adjustment is to be performed.

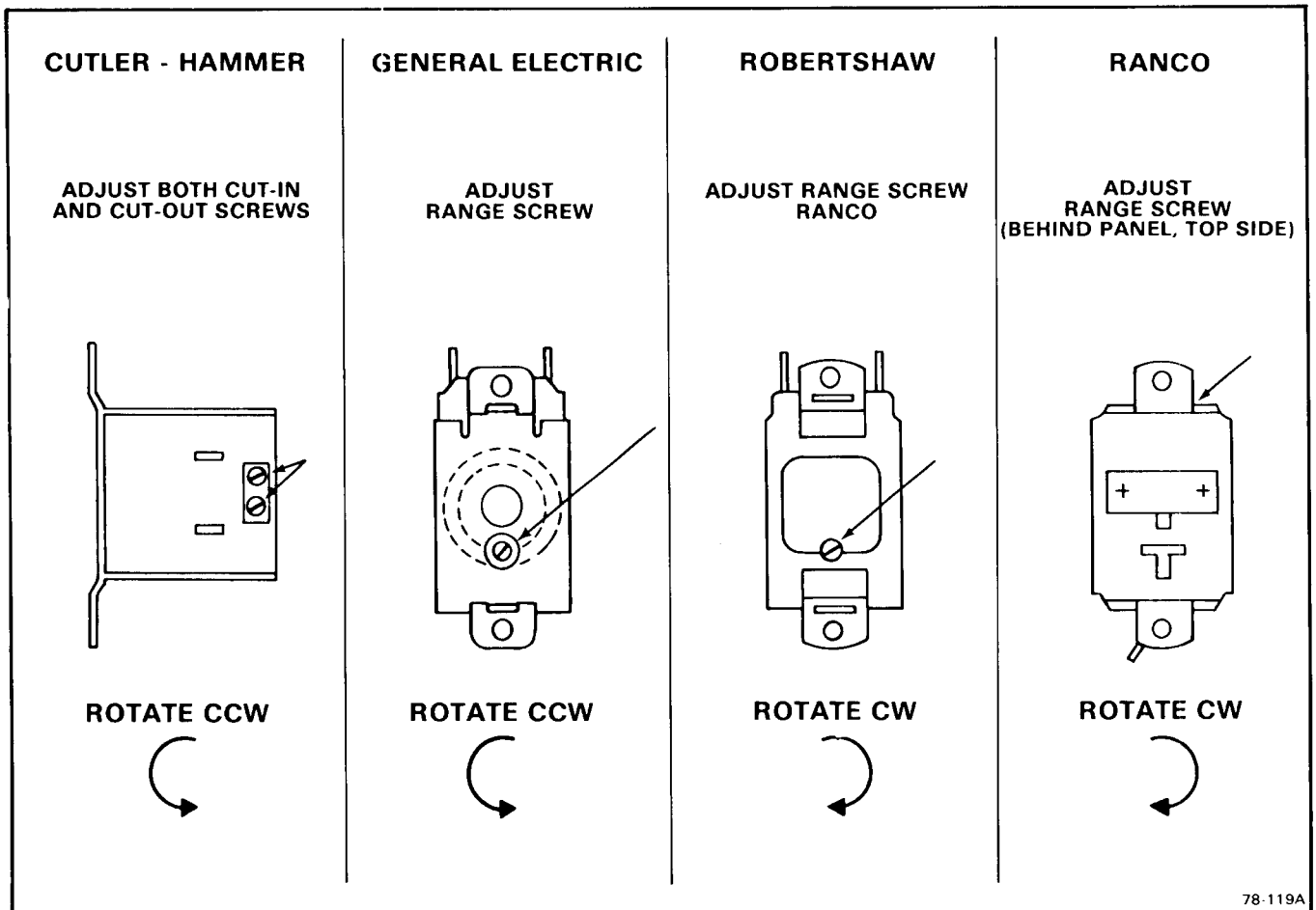

78-119A

Figure 4-1. Adjustment of the Temperature Control.

II. ADJUSTMENT OF THE LEG LEVELERS

When the AF-330 Icemaker is ordered with the optional Leg Levelers, the Cabinet must be leveled in the front-to-rear and side-to-side directions. This adjustment should be performed during initial installation of the Cabinet and anytime the Cabinet is moved from the original location to another site.

- A. Using an open-end wrench, and a carpenter's bubble level, rotate the threaded Leveler in each Leg to RAISE or LOWER the Cabinet until the Cabinet is level in the front-to-rear direction.
- B. Repeat step A, for leveling in the side-to-side direction.
- C. Recheck both the front-to-rear and the side-to-side leveling and repeat adjustments, as necessary.

III. ADJUSTMENT OF THE WATER RESERVOIR FLOAT

The correct water level in the Water Reservoir should be 3/8-inch below the raised molded line, on the side of the body of the Water Reservoir. When the water line level is above or below the raised molded line, adjustment can be performed to raise or lower the water level by raising or lowering the Water Reservoir in the slots on the Mounting Brackets, which in turn will adjust the action of the float.

- A. To RAISE the Water Level: Loosen the two Screws which attach the Water Reservoir Assembly to the Mounting Bracket and RAISE the Water Reservoir Assembly, in the slots, the desired amount; then, tighten the Screws.
- B. To LOWER the Water Level: Loosen the two Screws which attach the Water Reservoir Assembly to the Mounting Bracket and LOWER the Water Reservoir Assembly, in the slots, the desired amount; then, tighten the Screws.

WARNING

Be sure the electrical power supply and the water supply are OFF, before starting any of the following REMOVAL AND REPLACEMENT procedures, as a precaution to prevent possible personal injury or damage to equipment.

IV. REMOVAL AND REPLACEMENT OF THE AUGER, WATER SEAL, BEARINGS AND COUPLINGS

- A. To Remove the Auger, Water Seal, Bearings, and Coupling:
 1. Remove screws and the Left Front Lower Panel and the Left Side Panel.

2. Remove the Freezer Cap from the top of the Freezer Assembly.
3. Perform the steps in procedure IV-XI to remove the Spout Assembly.
4. Grasp the wire Cap Hook at the top of the Freezer Assembly and pull out the Auger and attached Cap, Bearing/Retainer, Bearing and O-Rings, at the top of the Auger; and, the top half of the Water Seal at the bottom of the Auger.

NOTE

When the Auger cannot be pulled out, proceed to steps 12 and 13, to gain access to the bottom of the Auger. Then, with a rawhide mallet or placing a piece of wood on the bottom end of the Auger, tap the bottom of the Auger to break it loose and pull the Auger out, as in step 4 above.

5. Remove the Cap Hook from the Bearing/Retainer.
6. Remove the Retaining Ring and the Cap.
7. Remove the Cap Screw and Washer and remove the Bearing/Retainer from the Auger.
8. Clean away the old grease from the top of the Auger, the Bearing/Retainer, Cap, Cap Screw and Washer, and the O-Ring and Retaining Ring.
9. Inspect the O-Ring at the top of the Bearing/Retainer and the O-Ring at the bottom outside of the Bearing/Retainer, for cuts, tears and general worn condition to determine replacement.
10. Inspect the Bearing pressed into the top of the Bearing/Retainer and, if it is to be replaced, remove the Retaining Ring and press the Bearing out of the Bearing/Retainer.
11. Slide the upper half of the Water Seal off of the bottom of the Auger.

NOTE

1. *Any time the Auger is removed for replacement, or, for the inspection and replacement of the Beariouppling, use extra care in handling the Water Seal parts, so no dirt or foreign matter are deposited on the surfaces of the Seal.*
2. *If there is any doubt about the effectiveness of Water Seal or O-Ring, REPLACE THEM. A dirty, worn or faulty Water Seal or O-Ring will cause a leak and ultimately require a second, time consuming removal and replacement procedure to be performed, that COULD HAVE BEEN PREVENTED.*
12. Remove four screws and lockwashers which attach the Freezer Assembly to the Adaptor on the Drivemotor Assembly.

13. Raise the Freezer Assembly off of the Adaptor, to gain access to the Bearing and Retainer; then, temporarily secure the Freezer Assembly out of the way to allow room to work. Be careful not to damage the gasket.
14. Using a suitable length and size wooden dowel or stick inserted through the top of the open Freezer Assembly, tap the lower half of the Water Seal and the lower Bearing in the Retainer, out of the bottom of the Freezer Assembly.
15. Inspect the lower half of the Water Seal. If reusable, use care to protect it from dirt, etc. prior to replacement procedure.
16. Inspect the lower Bearing in the Retainer; and, if the Bearing is to be replaced, press the Bearing out of the Retainer.
17. Reach through the Adaptor and remove the coupling on the Drivemotor for inspection.
18. Check the Coupling for cracks, chipping and excessive wear.

B. To replace the Auger, Water Seal, Bearings, and coupling, reverse the removal procedure.

NOTE

1. *When installing the Retainer assembled with Bearing, in the bottom of the Freezer Assembly, some Retainers will insert as a slip fit, and some will have to be forced into place because of very tight fit. Carefully tap a piece of wood positioned across the bottom of the Retainer, to evenly seat the Retainer in the chamber of the Freezer.*
2. *After assembling the parts on the upper end of the Auger and BEFORE installing the Cap and Cap Hook, apply an ample coating of shell Alvania 3 Grease, P/N 19-0309-01, to the upper part of the Bearing/Retainer to cover the Retaining Ring and the Cap Screw and Washer. Then, install the Cap and Cap Hook in place.*

V. REMOVAL AND REPLACEMENT OF THE COMPRESSOR ASSEMBLY.

NOTE

Always install a replacement Drier, any time the sealed refrigeration system is opened. Do not replace the Drier until all other repair or replacement has been completed.

A. Remove the Compressor Assembly:

1. Remove screws and the Left Side Panel and the Left Front Lower Panel.

2. Remove two screws and the Cover from the Compressor Junction Box.
3. Disconnect the electrical leads at the Compressor Junction Box, that originate in the Control Box.
4. Bleed off or blow the refrigerant charge through the Schrader valves.
5. Unsolder the suction line and the discharge line from the Compressor.
6. Unsolder the process header tube from the Compressor and retain for installation on the replacement Compressor.
7. Remove four bolts, lockwashers and washers which secure the Compressor to the Chassis mounting base.
8. Slide the Compressor and remove through the left side opening of the Cabinet.

NOTE

Thoroughly evacuate the system to remove moisture and non-condensables.

B. To replace the Compressor Assembly, reverse the removal procedure.

VI. REMOVAL AND REPLACEMENT OF THE CONDENSER — AIR-COOLED MODELS

NOTE

Always install a replacement Drier, any time the sealed refrigeration system is opened. Do not replace the Drier until all other repair or replacement has been completed.

A. To Remove the Condenser:

1. Remove screws and the Left Front Lower Panel and the Left Side Panel.
2. Bleed off or blow the refrigerant charge through the Schrader valve.
3. Unsolder and disconnect the Condenser inlet tube and the outlet tube at the Condenser.
4. Remove three screws, lockwashers and washers securing the Condenser to the Chassis Base.
5. Remove the Condenser out through the front opening of the cabinet.

NOTE

Thoroughly evacuate the system to remove moisture and non-condensables.

B. To replace the Condenser, reverse the removal procedure.

VII. REMOVAL AND REPLACEMENT OF THE DRIER

NOTE

Always install a replacement Drier, any time the sealed refrigeration system is opened. Do not replace the Drier until all other repair or replacement has been completed.

A. To Remove the Drier:

1. Remove screws and the Left Front Lower Panel and the Left Side Panel.
2. Remove screw and Drier Brace attaching the Drier to the Chassis base.
3. Bleed off or blow the refrigerant charge through the Schrader valve.
4. Unsolder refrigeration lines at each end of Drier, remove the Drier and separate the Drier from the Drier Brace.

B. To Replace the Drier:

CAUTION

1. If the factory seal is broken on the replacement Drier, exposing it to the atmosphere more than a few minutes, the Drier will absorb moisture from the atmosphere and lose substantial ability for moisture removal.
2. Be sure the replacement Drier is installed with the arrow positioned in the direction of the refrigerant flow.

1. Remove the factory seals from the replacement Drier and install the Drier in the refrigerant lines with the arrow positioned in the direction of the refrigerant flow.
2. Install the Drier Brace on the Drier.
3. Solder the Drier into the lines, two places.
4. Purge the system and check for leaks.
5. Thoroughly evacuate the system to remove moisture and non-condensables.
6. Charge the system with refrigerant, by weight. SEE NAMEPLATE.
7. Replace the Left Front Lower Panel and the Left Side Panel and attach both with screws removed earlier.

VIII. REMOVAL AND REPLACEMENT OF THE DRIVEMOTOR ASSEMBLY

A. To Remove the Drivemotor Assembly:

1. Perform all steps in procedure IV-X to gain access for removal of the Drivemotor Assembly.
2. Remove bolts, lockwashers and washers which attach the Drivemotor to the Chassis base.

3. Lift the Drivemotor from the Chassis base and out of the Cabinet.

B. To replace the Drivemotor Assembly, reverse the removal procedure.

IX. REMOVAL AND REPLACEMENT OF THE FAN MOTOR ASSEMBLY — AIR-COOLED MODELS

NOTE

Before beginning this procedure, observe the Fan Blade position on the shaft of the Fan Motor and mark the Fan Blade so it will be correctly positioned during reassembly. Direction of air flow should be toward the Fan Motor.

A. To Remove the Fan Motor Assembly:

1. Remove screws and the Left Front Lower Door and the Left Side Panel.
2. Disconnect the electrical lead from the Fan Motor.
3. Remove two screws securing the Motor Bracket to the Chassis Base and remove the Fan Motor and Motor Bracket out through the left side opening of the Chassis.
4. Remove the nut from the end of the Fan Motor shaft and remove the Fan Blade.
5. Remove four screws securing the Fan Motor to the Motor Bracket and separate the Motor from the Bracket.

B. To replace the Fan Motor Assembly, reverse the removal procedure.

X. REMOVAL AND REPLACEMENT OF THE FREEZER ASSEMBLY

NOTE

1. The Cabinet may have to be removed from its permanent location, especially if located in a corner, in order to have access to the left side and rear of the Chassis.
2. In addition to shutting OFF electrical power and inlet water to the icemaker, be sure to disconnect the inlet water line at the rear of the Cabinet BEFORE moving the icemaker from the permanent location.
3. Always install a replacement Drier, anytime the sealed refrigeration system is opened. Do not replace the Drier until all other repair or replacement has been completed.

A. To Remove the Freezer Assembly, see Figure 4-2:

1. Remove screws and left side, front and rear panels.
2. Refer to procedure IV-XI and remove the Spout Assembly.

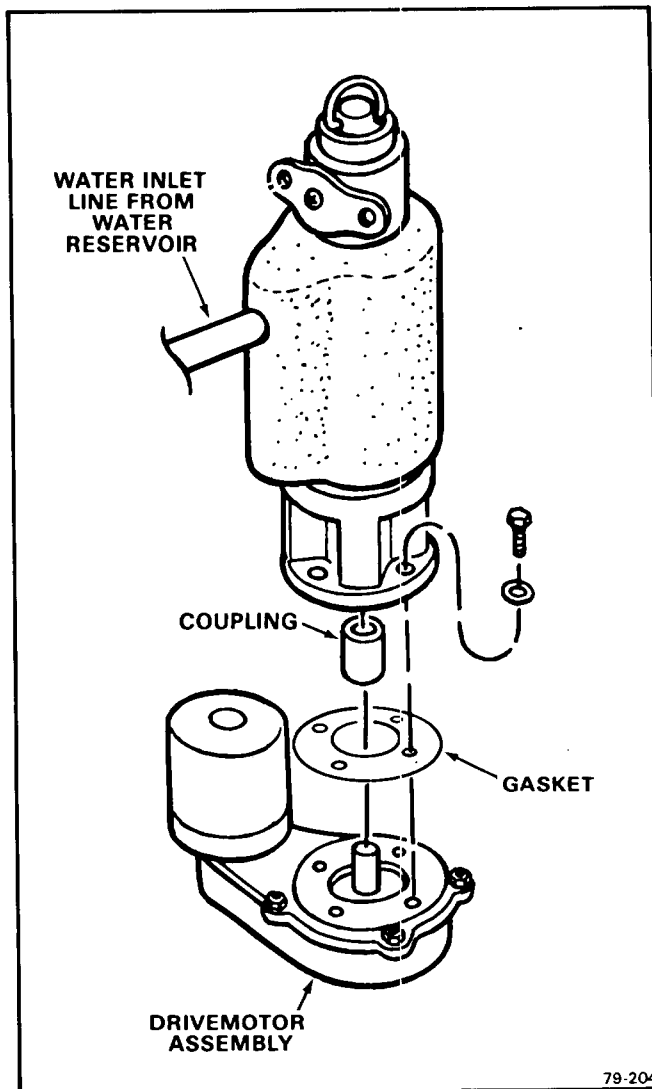

Figure 4-2. Removal of the Freezer Assembly.

3. Remove Corbin clamp and Tygon tube from the Freezer Assembly that connects to the Water Reservoir Assembly.
4. Bleed off or blow the refrigerant charge through the Schrader valve.
5. Unsolder the suction line from the Compressor.
6. Unsolder the capillary line at the Drier.
7. Remove four screws, lockwashers and washers which attach the bottom of the Freezer Assembly to the Adaptor on the Drivemotor Assembly.
8. Lift the Freezer Assembly up and off of the Adaptor and Drivemotor Assembly.

NOTE

Thoroughly evacuate the system to remove moisture and non-condensables.

- B. To replace the Freezer Assembly, reverse the removal procedure.

XI. REMOVAL AND REPLACEMENT OF THE SPOUT ASSEMBLY.

- A. To Remove the Spout Assembly, See Figure 4-3:

1. Remove screws and the Left Front Lower Panel and Left Side Panel.
2. Remove the Hose Clamp and disconnect the Nylobraid tube from the end of the spout.
3. Remove the Freezer Cap from the top of the Freezer Assembly.
4. Disconnect the electrical leads from the Spout Switch.
5. Remove two screws and washers and separate the Spout Assembly from the Spout Plate on the Freezer Assembly.

NOTE

At this time, inspect the Spout Gasket and retain for the replacement procedure. Replace a torn, cut or worn, defective gasket.

- B. To replace the Spout Assembly, reverse the removal procedure.

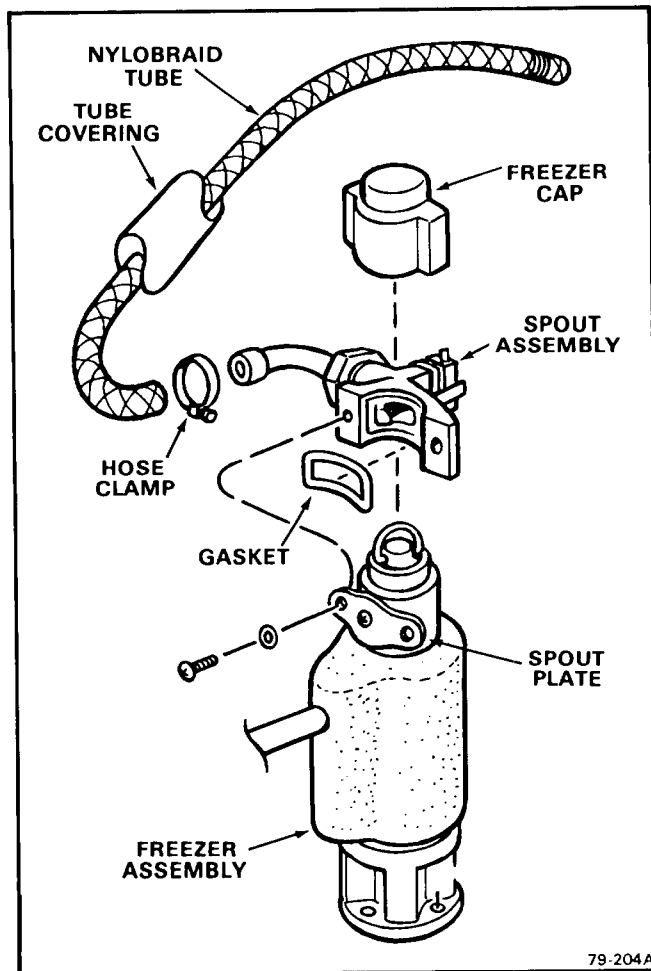

Figure 4-3. Removal of the Spout Assembly.

XII. REMOVAL AND REPLACEMENT OF THE WATER PRESSURE CONTROL

A. To Remove the Water Pressure Control:

1. Remove screws and the Left Front Lower Panel and the Left side Panel.
2. Remove screws and the Control Box Cover.
3. Disconnect the two blue electrical leads of the Water Pressure Control, from the terminals on the Auger Delay Control and the Bin Thermostat device in the Control Box Assembly.
4. Unscrew the flare nut fitting and disconnect the Water Pressure Control from the Utility Bracket and the Tee on the inlet water tubing.

NOTE

At this time, inspect the O-Ring and retain for the replacement procedure. Replace O-ring that is cut, torn or indicates excessive wear.

- ### B. To replace the Water Pressure Control,
- reverse the removal procedure.

XIII. REMOVAL AND REPLACEMENT OF THE WATER RESERVOIR ASSEMBLY

A. To Remove the Water Reservoir Assembly, see Figure 4-4:

1. Remove screws and the Left Front Lower Panel and the Left Side Panel.

NOTE

Be prepared with container or rags, to catch water left in lines, when lines are disconnected in next steps, to prevent draining water on parts, components, electrical lines, etc.

2. Disconnect the water inlet tube from the Water Reservoir Assembly.
3. Remove two Corbin clamps and two tubes from the bottom of the Water Reservoir Assembly.
4. Unscrew and remove the wing nut from the bottom of the Water Reservoir Assembly.

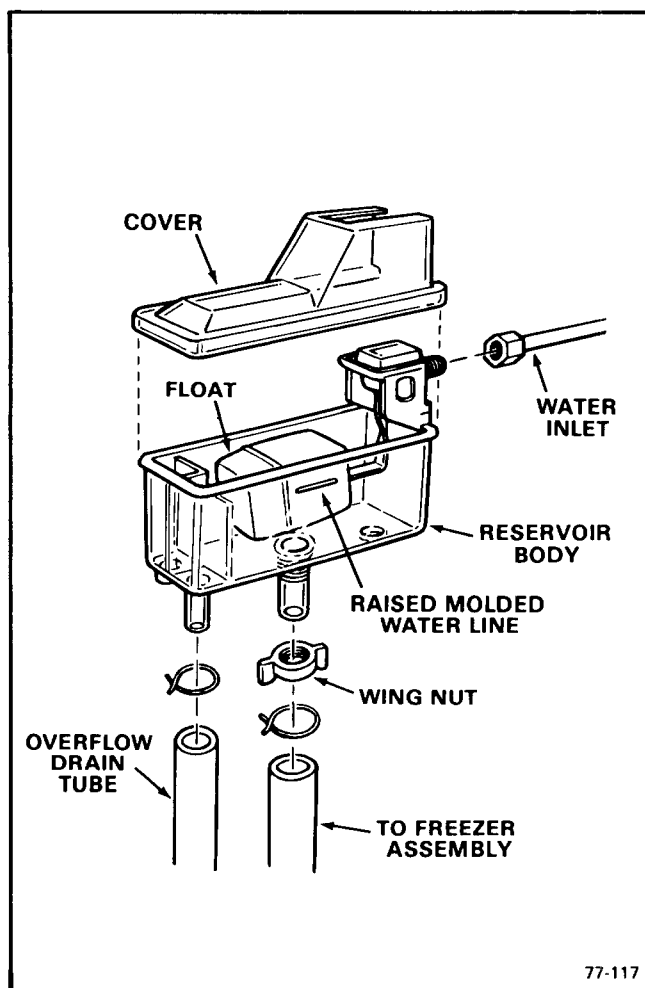

Figure 4-4. Removal of the Water Reservoir Assembly

5. Lift and remove the Water Reservoir Assembly from the mounting bracket.

- ### B. To replace the Water Reservoir Assembly,
- reverse the removal procedure.

NOTE

Check that the installed replacement Water Reservoir Assembly float moves freely. Bend metal arm of float to adjust, as necessary. The correct water level in the Water Reservoir is 3/8-inch below the raised molded line, on the side of the body of the Water Reservoir.

SECTION V

MAINTENANCE AND CLEANING INSTRUCTIONS

I. GENERAL

The periods and procedures for maintenance and cleaning are given as guides and are not to be construed as absolute or invariable. Cleaning especially will vary, depending upon local water conditions and the ice volume produced; and, each Icemaker must be maintained individually, in accordance with its own particular location requirements.

II. ICEMAKER

THE FOLLOWING MAINTENANCE SHOULD BE SCHEDULED AT LEAST TWO TIMES PER YEAR ON THIS ICEMAKER. CALL YOUR AUTHORIZED SCOTSMAN SERVICE AGENCY.

1. Check and clean water line Strainers.
2. Remove cover from Water Reservoir and depress the float to ensure that a full stream of water enters the Reservoir.
3. Check that the Icemaker cabinet is level, in side-to-side and front-to-rear directions.
4. Check that the water level in the Water Reservoir is below the overflow, but high enough that it does not run out of the spout opening.

NOTE

It is not abnormal for some water to emerge from the Ice Spout with flaked ice during normal ice production.

5. Clean the Water Reservoir and interior of the Freezer Assembly, using a solution of SCOTSMAN Ice Machine Cleaner. Refer to procedure V-III, CLEANING-Icemaker.

NOTE

Cleaning requirements vary according to local water conditions and individual user operation. Visual inspection of the Auger before and after cleaning will indicate frequency and procedure to be followed in local areas.

6. When doubtful about refrigerant charge, install refrigerant gauges on Schrader valves and perform steps 6 and 7. Check gauge for Compressor head pressure:

AIR-COOLED MODELS: Varies between 130 and 145 PSIG.

7. Check gauge for Suction line pressure:
Varies between 12 to 16 PSIG, depending upon inlet water temperature and ambient air temperature.
8. Check Drivemotor operation:
Normal operating temperatures are about 160-degrees F., which is hot to touch.
9. Check operation of the centrifugal sensing switch:
AF-330: 1/10 HP Motor.
Switch will OPEN between 400-600 RPM and the Compressor STOPS, with the Drivemotor operating. Switch will CLOSE between 1300-1400 RPM and the Compressor will RESTART, with Drivemotor building back up to normal operating speed.
10. Remove the Freezer Cap, the Retaining Ring and the Hook and Cap from the top of the Freezer Assembly.
11. Inspect the Top Bearing. If moisture is around Bearing, wipe clean of all grease and apply a coating of Shell Alvania 3 Grease, Scotsman P/N 19-0309-01. Replace parts removed in step 10.

NOTE

BEFORE next step, move the manual ON-OFF toggle switch, on top of the Control Box, to the OFF position to stop the Fan Motor and Icemaker.

12. Clean the Air-Cooled Condenser, using vacuum cleaner, whisk broom or brush. Instruct customer to clean frequently and to be sure Icemaker and Fan Motor are OFF.
13. Check that Fan Blades move freely, are not touching any surfaces and are not bent or out of balance.
14. Check for refrigerant leaks and for proper frost line, which should frost out of accumulator to within no closer than eight to twelve inches of the Compressor.
15. Check for water leaks, Tighten drain line connections. Pour water down Bin drain to be sure that drain line is open and clear.

16. Check the quality of ice. Ice flakes should be wet when formed, but will cure rapidly to normal hardness in the Bin.
17. Check the Bin Thermostat Ice Control Bulb.

NOTE

The Bin Thermostat is factory set at 10-degrees F. differential and should keep the entire Icemaker system shut off at least 10 minutes in high ambient temperatures, longer in low ambient temperatures during normal operation. Settings are 35-degrees F. CUT-OUT and 45-degrees F. CUT-IN.

18. Check the Spout Switch.

NOTE

The Spout Switch is manually reset and functions as a safety switch, to automatically stop the icemaking process if the Bin Thermostat Bulb were to fail and cause ice to jam up in the Ice Tube.

III. CLEANING - Icemaker

1. Remove screws and the Lower Left Front Panel.
2. Move the manual ON-OFF toggle switch, on top of the Control Box, to the OFF position.
3. Remove all ice from the Ice Storage Bin.
4. CLOSE the water supply shutoff valve; or block the float in the Water Reservoir.
5. Disconnect the tube between the Water Reservoir and the bottom of the Freezer Assembly and drain water from the Reservoir and tube. Reconnect the tube.

WARNING

SCOTSMAN Ice Machine Cleaner contains Phosphoric and Hydroxycetic acids. These compounds are corrosive and may cause burns if swallowed. DO NOT induce vomiting. Give large amounts of water or milk. Call physician immediately. In case of external contact flush with water. KEEP OUT OF THE REACH OF CHILDREN.

6. Prepare cleaning solution: Mix four ounces of SCOTSMAN Ice Machine Cleaner with one quart of hot water.
7. Remove the Cover to the Water Reservoir.
8. Slowly pour the cleaning solution into the Water Reservoir.
9. Move the manual ON-OFF toggle switch, on top of the Control Box, to the ON position.
10. Continue to slowly pour the cleaning solution into the Water Reservoir, maintain level just below the Reservoir overflow.
11. Continue icemaking, using the cleaning solution, until all the solution is used up and the Water Reservoir is almost empty. DO NOT allow the icemaker to operate with empty Reservoir.
12. Move the manual ON-OFF toggle switch, on top of the Control Box to the OFF position.
13. Wash and rinse the Water Reservoir.
14. OPEN the water supply shutoff valve; or remove the block from the float in the Water Reservoir.
15. Move the manual ON-OFF toggle switch, on top of the Control Box, to the ON position.
16. Continue icemaking for at least 15 minutes, to flush out any cleaning solution. Check ice for acid taste - continue icemaking until ice tastes sweet.
17. Move the manual ON-OFF toggle switch, on top of the Control Box to the OFF position.

CAUTION

DO NOT use ice produced from the cleaning solution. Be sure none remains in the bin.

18. Remove all ice from the Ice Storage Bin.
19. Add hot water to the Ice Storage Bin and thoroughly wash and rinse all surfaces within the Bin.
20. Clean and sanitize the Ice Storage Bin each week.

SECTION VI SERVICE DIAGNOSIS

The Service Diagnosis Section is for use in aiding the serviceman in diagnosing a particular problem for pin-pointing the area in which the problem lies, thus an ever available reference for proper corrective action.

The following charts list corrective actions for the causes of known symptoms of certain problems that can occur in the Icemaking - Refrigeration System.

I. ICEMAKING - REFRIGERATION SYSTEM

SYMPTOM	POSSIBLE CAUSE	CORRECTION
Water Leaks.	Defective water seal. Gravity feed line leaking. Water level in reservoir too high. Storage bin drain and connecting fittings.	Replace Seal. Check hose clamps. Adjust water level to $\frac{3}{8}$ -inch below reservoir overflow, then raise reservoir until water flows out freezer spout, then lower reservoir $\frac{3}{4}$ -inch. Check and repair.
Excessive noise or chattering.	Mineral or scale deposit on auger and inner freezing chamber walls. Intermittent water supply. Water level in reservoir too low. Gear Reducer loose on frame. Motor compressor not solid on rubber mounts. Gearmotor end-play or worn bearing.	For severe deposit, remove and manually polish auger, sand inner chamber walls of freezer barrel. For lighter concentration, use Scotsman Ice Machine Cleaner periodically. Check and clean water strainer. Check gravity feed line for air lock. Remove air lock. See CORRECTION for Water Leaks above. Tighten Gear Reducer. Repair or replace rubber mounts. Repair or replace bearing.
Making wet ice. (Ice melts too quickly, is not cold enough to properly cure in the Bin.)	Surrounding air temperature too high. Under or over-charge of refrigerant.	Correct or move cabinet. Recharge with proper amount. Should frost out of accumulator at least 8-inches. See nameplate for correct charge. See CORRECTION for Water Leaks above.

ICEMAKING - REFRIGERATION SYSTEM (Con't)

SYMPTOM	POSSIBLE CAUSE	CORRECTION
Making wet ice (cont'd)	Back pressure too high. Faulty compressor or valve plate.	Overcharge of refrigerant, Faulty compressor or high head pressure. Lower pressure as indicated. Repair or replace compressor or valve plate.
Low ice production.	Loss of refrigerant. Under or over-charge of refrigerant. Drivemotor weak. Dirty or plugged condenser. Low water level in water reservoir. Partial restriction in capillary tube or drier. Inlet water strainer partially plugged. Corroded or stained auger due to water condition.	Check and recharge. See NAMEPLATE for correct charge Replace Drivemotor. Clean condenser. See CORRECTION for Water leaks above. Moisture in system. Overcharge of oil in system. Remove charge by blowing back through cap tube. Replace drier and recharge. Remove screen and clean. Remove auger and clean, or use Scotsman Ice Machine Cleaner. See Maintenance Section
Gearmotor noise.	Low on oil.	Remove case cover to check for proper oil level. Top of gears should be covered. Use: Sun Oil Company Prestige 50-EP
Icemaker will not operate	Blown fuse in line. Bin thermostat set too high. Loose electrical connection. Switch in OFF position. Inoperative master switch. Off on manual-reset pressure control.	Replace fuse and check for cause of blown fuse. Adjust thermostat. Set at 35-degrees cut-out, 45-degrees cut-in. Check wiring. Set switch to ON position. Replace switch or thermal overload. Reset.
Icemaker continues to operate with full storage bin.	Bin thermostat not properly set or is defective.	Re-set or replace bin thermostat re-set to 35-degrees cut-out, 45-degrees cut-in.
Compressor cycles intermittently.	Low voltage. Dirty condenser. Air circulation blocked. Inoperative condenser fan motor.	Check for overloading. Clean condenser. Remove cause or move unit. Replace motor.

ICEMAKING - REFRIGERATION SYSTEM (Cont'd)

SYMPTOM	POSSIBLE CAUSE	CORRECTION
Compressor cycles intermittently (cont'd)	<p>Non-condensable gases in system.</p> <p>Bin thermostat differential too small causing short cycling.</p> <p>Cycling on ice spout microswitch.</p>	<p>Check for gas leaks, evacuate and recharge.</p> <p>Widen differential 35-degrees cut-out, 45-degrees cut in.</p> <p>Set or replace Bin Thermostat.</p>
Icemaker operates but makes no ice.	<p>Loss or undercharge of refrigerant.</p> <p>Water not entering freezing chamber.</p> <p>Air lock in gravity feed line.</p> <p>Moisture in system.</p> <p>Water seal leaking.</p> <p>Water turned off while unit was operating.</p> <p>Drivemotor or drive coupling stripped.</p>	<p>Check for leaks and recharge See NAMEPLATE for correct charge.</p> <p>Plugged strainer or supply line. Check and clean.</p> <p>Check and remove air lock.</p> <p>Check, evacuate, replace drier. Recharge. See NAMEPLATE for correct charge.</p> <p>Replace seal.</p> <p>Freezer inlet water line froze shut. Unit must be shut OFF and defrosted.</p> <p>Repair or replace drivemotor or drive coupling.</p>

SECTION VII

WIRING DIAGRAMS

This Section is provided as an aid in understanding the electrical circuitry of the Automatic Flaker.

The Wiring Diagram in this Section is: Figure 7-1. Wiring Diagram AF-330 - Air-Cooled.

WARNING

When conducting a continuity check of the Automatic Flaker:

1. Disconnect the main power source.
2. DO NOT use an incandescent lamp or jumper wire, conduct all tests with a volt-ohm-meter.

A28220-001

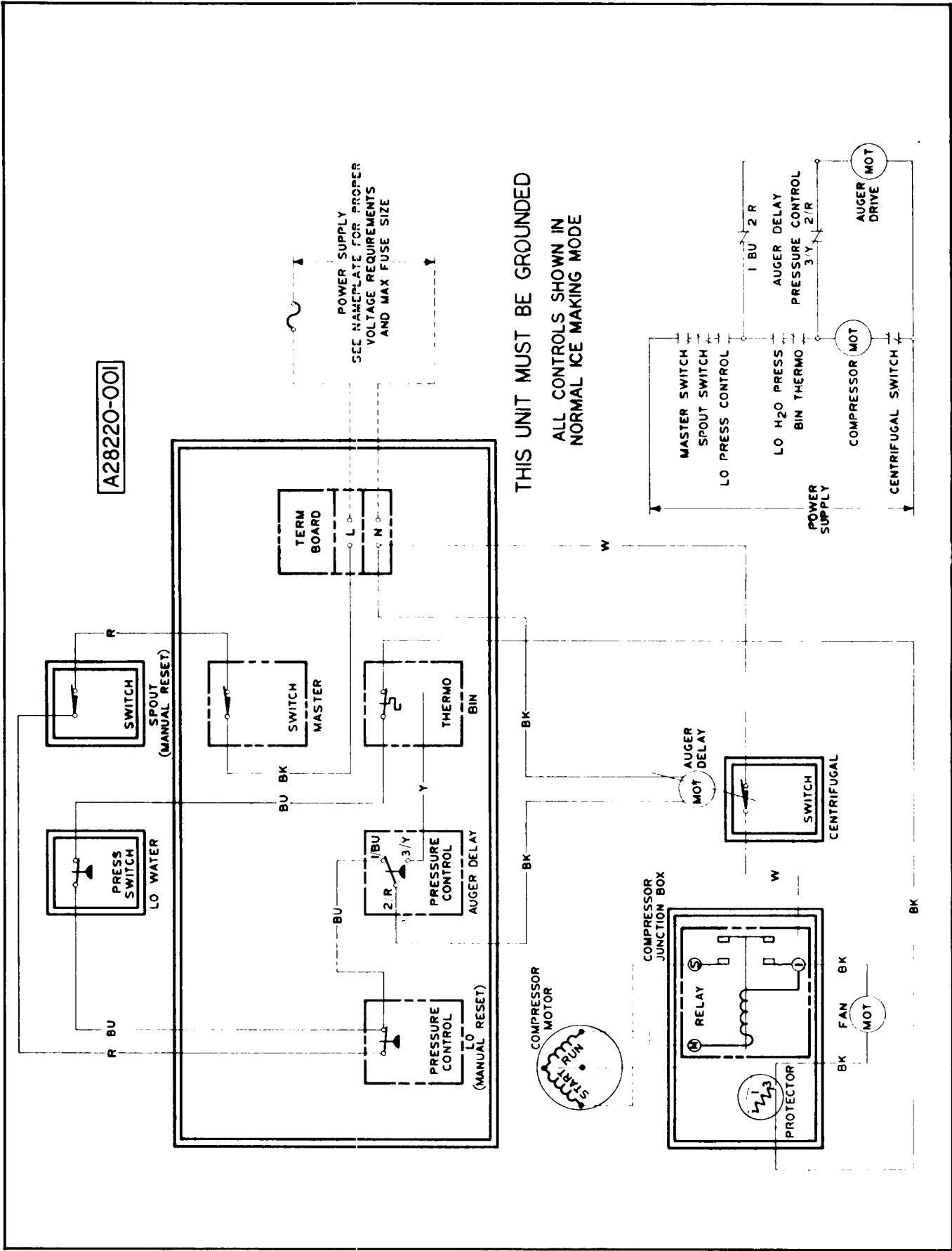

Figure 7-1. Wiring Diagram AF-330 - Air-Cooled.

SECTION VIII

THE PARTS ILLUSTRATIONS AND PARTS LISTS

I. GENERAL

This section contains the Parts Illustrations and the Parts List for each of the major assemblies in the AF-330 Automatic Flaker.

Each Parts Illustration shows an assembly as an exploded view, with an Index Number for each part or sub-assembly, given in disassembly order. These Index Numbers key with the Parts List for the assembly and are found in the Parts List Column headed Index Number. The Description Column gives the identifying nomenclature for the item indexed. The Part Number Column gives the number of item. The Number Required Column gives the number of items required per assembly, but not necessarily the total number of parts required per Flaker.

All assemblies are cross-referenced both from the major assembly listing where they first appear in the parts Listing to their break-down listing, and from the break-down listing, back to the major assembly (next higher assembly) listing.

A *No Number* designation, when used in the Part Number Column indicates the unit is not available from SCOTSMAN as an assembly. This designation is used only for the convenience and clarity of division in cataloging.

When an Index Number is followed by a letter (e.g. la. lb.), the letter indicates the part listed is part of the assembly indexed by the basic Index Number. The number required of the part indexed by the number and letter combination is for only one of the assemblies indexed by the

basic Index Number and not necessarily the total number of parts used in the Flaker. Where the notation *Ref* occurs in the Number Required Column the number of the assemblies or parts required for use in the Flaker will be found under previous Index Number or in the next higher assembly Parts Listing. The next higher listing Figure/Index number is shown in the Description Column immediately following the items description.

II. HOW TO USE THE ILLUSTRATIONS AND PARTS LIST

To find the part number of a required part or assembly, turn to the List of Illustrations and find the page number of the Parts Illustration of the major or sub-assembly containing the part. Turn to the indicated page and locate the part and its Index Number on the specific illustration. Find the Index Number on the required part in the Parts List to determine the complete description of the part.

III. HOW TO ORDER PARTS OR ASSEMBLIES

When ordering parts or assemblies, to avoid costly delays and errors in shipment, give the part number, the complete description shown in the list, and the quantities of each part or assembly required. Also include the Model name, the serial number of the Flaker for which the part is required, and for parts which require color matching, the color of the Cabinet. See Figure 8-00, at the end of this section for detailed ordering instructions.

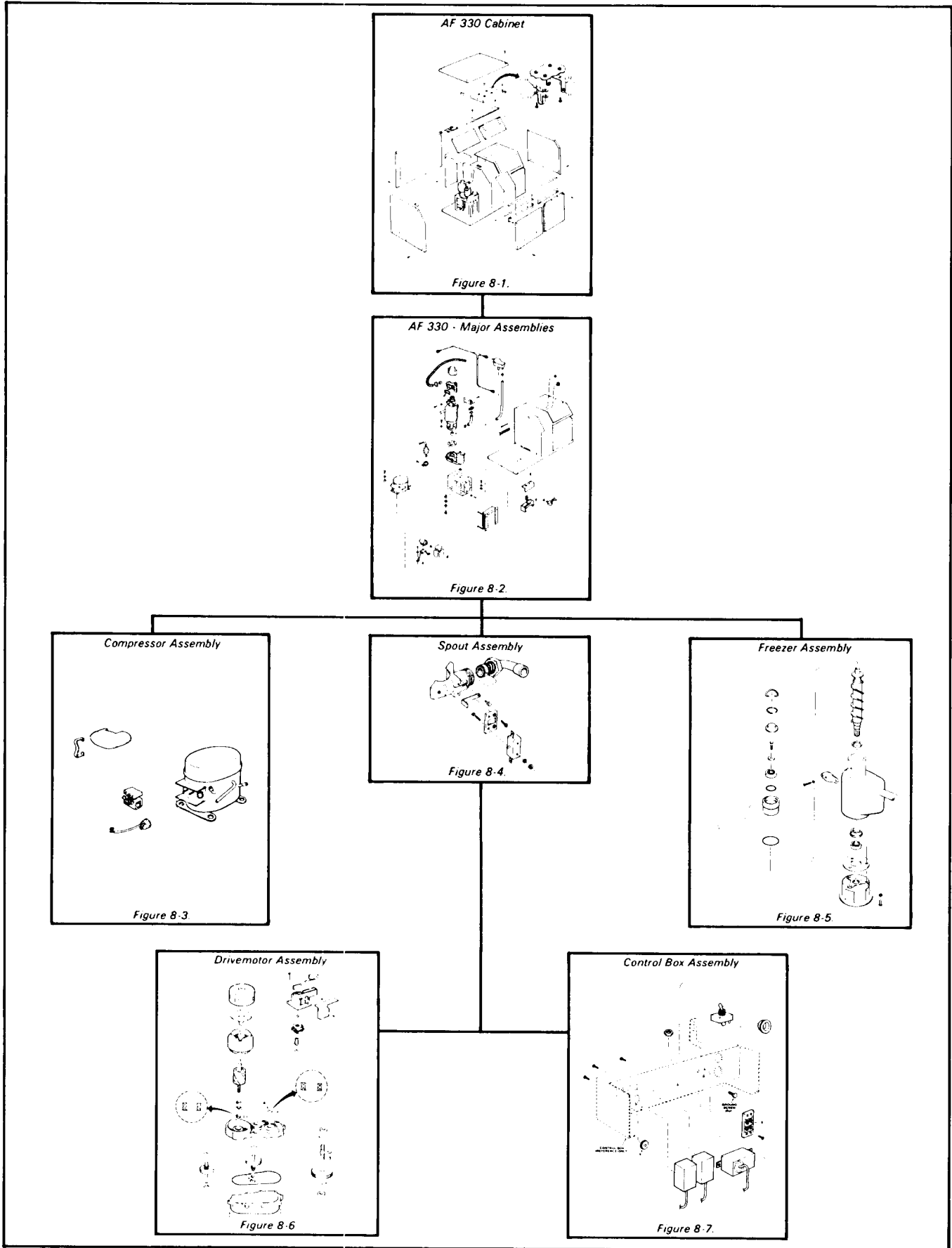
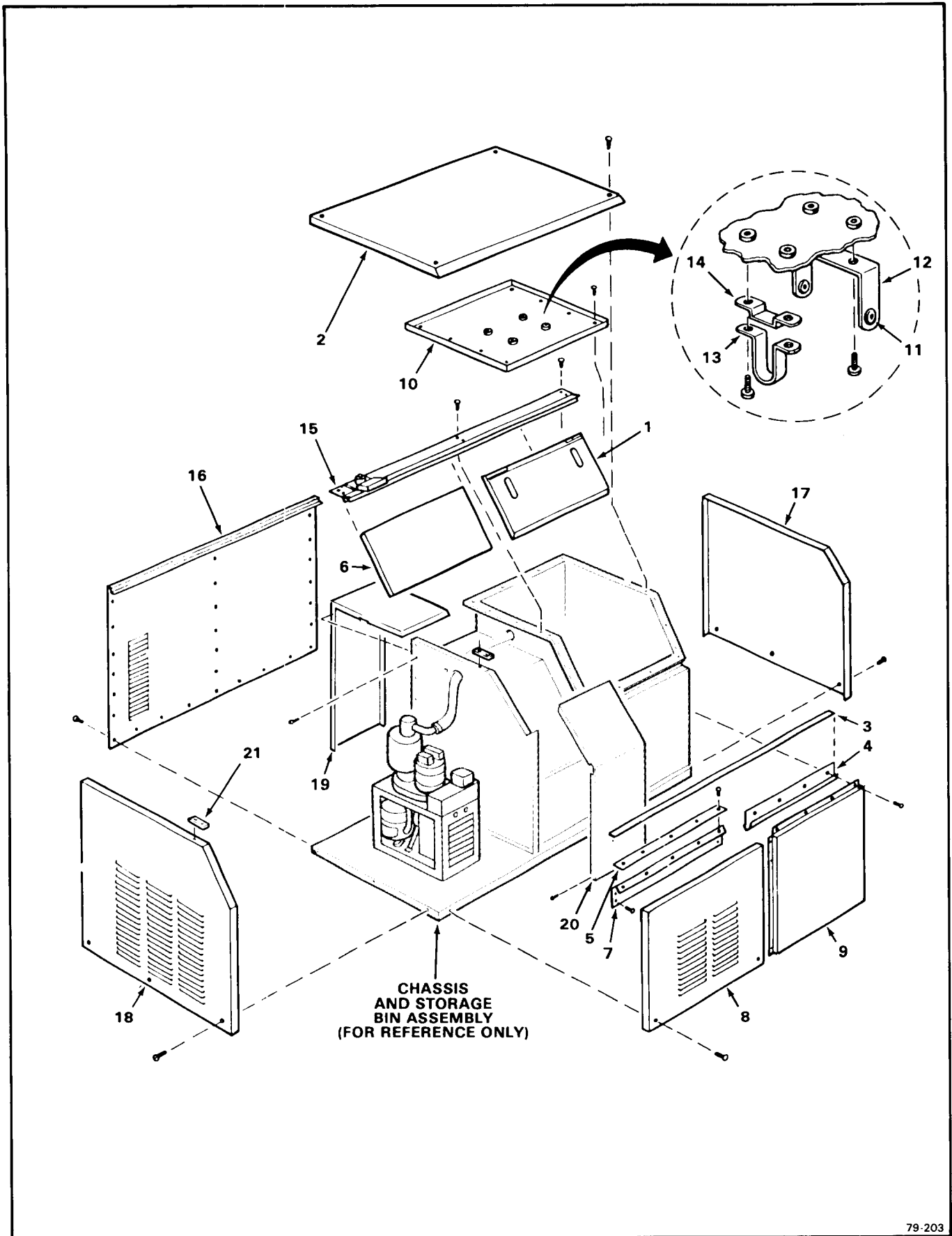

Figure 8-A. Automatic Flaker AF-330 Flow Chart



79-203

Figure 8-1. AF-330 Cabinet

Figure 8-1. AF-330 Cabinet.

INDEX NO.	DESCRIPTION	PART NUMBER	REQ'D NUMBER
	AF-330 Cabinet * * *	No Number	1
1	Door, Ice Access (Orange w/C.R.S. Painted Cabinet) Door, Ice Access (Gray w/Stainless Steel Cabinet) * * *	02-2130-01 02-2130-02	1 1
2	Panel, Top (C.R.S. Painted) Panel, Top (Stainless Steel) attaching parts, Index 2	A24799-003 A24799-002	1 1
	Screw, No. 8 x 1-3/4 S/T Flat Hd * * *	03-1419-19	4
3	Insert, Plastic * * *	15-0324-00	1
4	Strip, Moulding — Right Side attaching parts, Index 4 & 9 Screw, No. 8 x 3/8 S/T Flat Hd * * *	15-0620-01 03-1419-05	1 4
5	Strip, Moulding — Left Side attaching parts, Index 5 to 8 Screw, No. 8 x 3/8 S/T Flat Hd * * *	15-0578-01 03-1419-05	1 5
6	Panel, Upper — Left Front (C.R.S. Painted) Panel, Upper — Left Front (Stainless Steel) * * *	A24795-003 A24795-002	1 1
7	Bracket, Left Front attaching parts, Index 5 & 7 Screw, No. 8 x 1/2 T/F Tap * * *	A28825-001 03-1404-09	1 4
8	Panel, Lower — Left Front (C.R.S. Painted) Panel, Lower — Left Front (Stainless Steel) attaching parts, Index 8 Screw, No. 8 x 1-1/2 S/T Flat Hd	A24796-003 A24796-004 03-1419-16	1 1 2

Figure 8-1. AF-330 Cabinet. (cont'd)

INDEX NO.	DESCRIPTION	PART NUMBER	REQ'D NUMBER
9	Panel, Right Front (C.R.S. Painted)	A24794-003	1
	Panel, Right Front (Stainless Steel)	A24794-002	1
	attaching parts, Index 4 & 9		
	Screw, No. 8 x 3/8 S/T Flat Hd	03-1419-05	Ref.

10	Cover, Storage Bin	A27980-001	1
	attaching parts, Index 10		
	Screw, No. 8 x 1/2 T/F Tap	03-1404-09	10

11	Grommet	13-0557-00	2

12	Bracket, Bin Thermo	A27924-001	1

13	Holder, Tube	A27922-001	1

14	Retainer, Tube	A27923-001	1
	attaching parts, Index 12, 13, 14 to 10		
	Screw, Thumb — No. 10-24 x 1/2 Knurled Hd	03-0727-00	4

15	Track Assembly, Door	A28823-001	1
	attaching parts, Index 15		
	Screw, No. 8 x 1/2 T/F Tap	03-1404-09	6

16	Panel, Back (Galvanized Steel)	A28828-001	1
	attaching parts, Index 16		
	Lockwasher, No. 8 External Tooth — Carbon Steel Zinc Plated	03-1417-03	4
	Screw, No. 8 x 1/2 T/F Tap	03-1404-09	27

17	Panel, Right Side (C.R.S. Painted)	A24800-003	1
	Panel, Right Side (Stainless Steel)	A24800-002	1
	attaching parts, Index 17		

Figure 8-1. AF-330 Cabinet. (cont'd)

INDEX NO.	DESCRIPTION	PART NUMBER	REQ'D NUMBER
	Screw, No. 8 x 1/2 T/F Tap (SS) * * *	03-1404-10	5
18	Panel, Left Side (C.R.S. Painted)	A27034-003	1
	Panel, Left Side (Stainless Steel)	A27034-002	1
	attaching parts, Index 18		
	Lockwasher, No. 8 External Tooth — Carbon Steel Zinc Plated	03-1417-03	2
	Screw, No. 8 x 1/2 T/F Tap (SS) * * *	03-1404-10	3
19	Retainer, Ext. Rear * * *	A28141-001	1
20	Retainer, Ext. Front * * *	A28144-001	1
21	Spacer, Door Track attaching parts, Index 19, 20, 21	A24955-001	2
	Screw, No. 8 x 1/2 T/F Tap (SS) * * *	03-1404-10	A/R

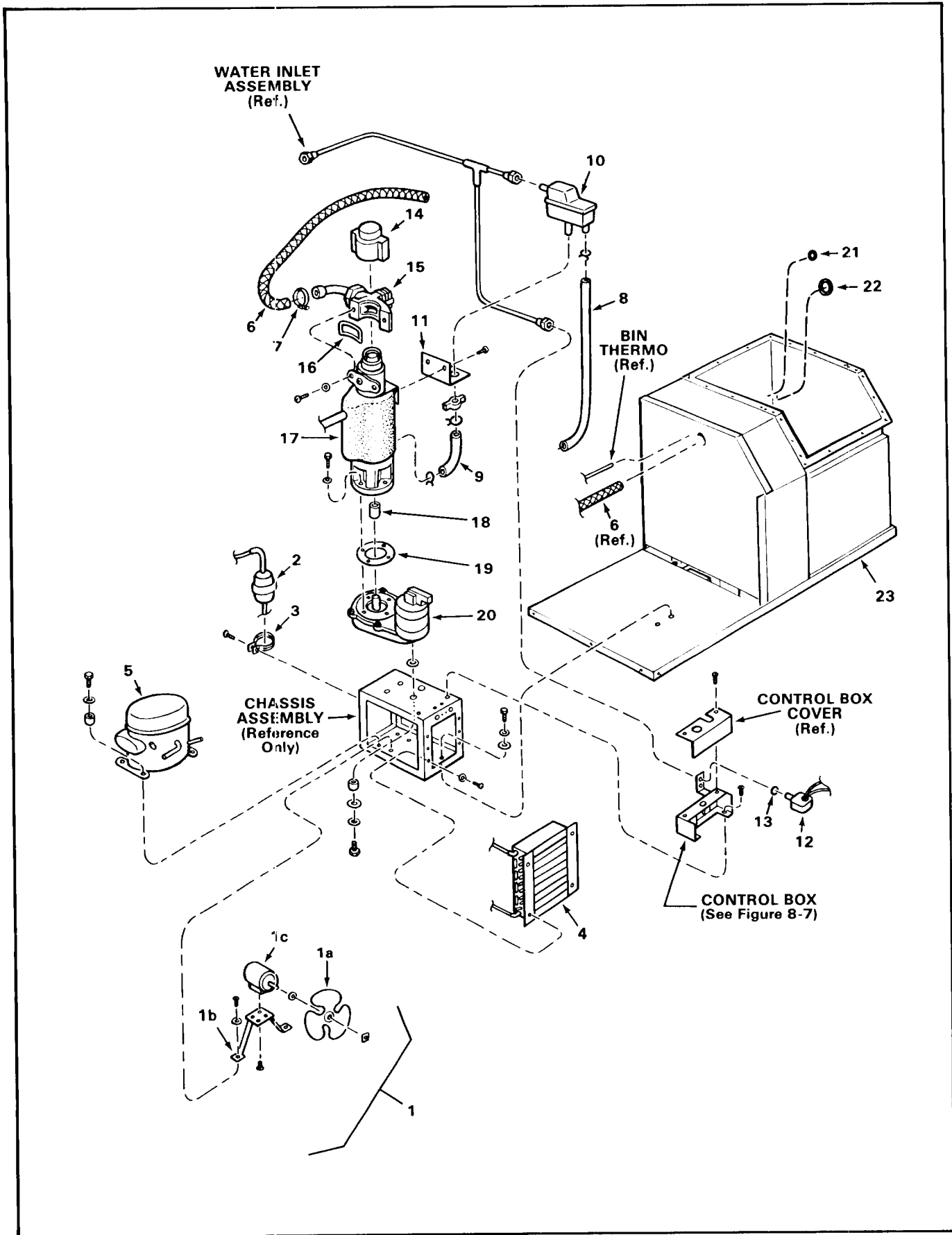

Figure 8-2. AF-330 - Major Assemblies

Figure 8-2. AF-330 - Major Assemblies

INDEX NO.	DESCRIPTION	PART NUMBER	REQ'D NUMBER
	Major Assemblies - AF-330 * * *	No Number	Ref.
1	Bracket Assembly, Fan Motor & Mounting	No Number	1
1a	Blade, Fan	18-3728-01	1
	Pad, Vibration (p/o Fan Motor)	No Number	1
	Nut, Fan Mounting (p/o Fan Motor)	No Number	1
1b	Bracket, Fan Mounting	A25548-001	1
1c	Motor, Fan	12-1575-01	1
	attaching parts, Index 1c to 1b		
	Screw, No. 8-36 (p/o Fan Motor)	No Number	4
	attaching parts, Index 1 to Chassis Base		
	Lockwasher, No. 1/4 External Tooth - Carbon Steel Zinc Plated	03-1417-09	2
	Screw, No. 1/4-20 x 1/2 T/C Hex Hd	03-0571-00	2
	* * *		
2	Drier	02-2426-01	1
	* * *		
3	Brace, Drier	A09386-000	1
	attaching parts, Index 2 and 3		
	Lockwasher, No. 10 External Tooth - Carbon Steel Zinc Plated	03-1417-05	1
	Screw, No. 10 x 3/4 T/F Tap	03-1404-32	1
	* * *		
4	Condenser - Air-Cooled	18-3727-01	1
	attaching part, Index 2		
	Lockwasher, No. 10 External Tooth - Carbon Steel Zinc Plated	03-1417-05	4
	Screw, No. 10 x 3/8 T/F Tap	03-1404-15	4
	* * *		
5	Compressor	18-4700-01	1
	(See Figure 8-3)		
	attaching parts, Index 3		
	Grommet	18-4700-28	4
	Sleeve	18-0108-41	4

Figure 8-2. AF-330 - Major Assemblies (cont-d)

INDEX NO.	DESCRIPTION	PART NUMBER	REQ'D NUMBER
	Lockwasher, No. 5/16 Helical Spring	03-1410-04	4
	Washer, Special	03-1408-29	4
	Screw, No. 5/16 x 1-1/2 Hex Cap	03-1405-20	4
	* * *		
6	Tube, Ice attaching part, Index 6	A248042-004	1
	* * *		
7	Clamp, Hose	02-0179-02	1
	* * *		
8	Tube (Reservoir overflow to Drain)	13-0079-03	1
	* * *		
9	Tube (2-1/2-inch lg.) (Reservoir to Freezer Inlet) (Order tubing by the foot) attaching parts, Index 8 and 9	13-0674-09	1
	Clamp (use with Index 8)	02-0535-00	1
	Clamp (use with Index 9)	02-0694-00	2
	* * *		
10	Reservoir	02-2217-01	1
	Valve Assembly, Float (Not shown) attaching part, Index 10	02-2217-02	1
	Wing Nut (plastic - p/o Reservoir)	No Number	1
	* * *		
11	Bracket, Reservoir attaching part, Index 11	A28240-001	1
	Screw, No. 10-24 x 3/8 Pan Hd	03-1403-26	2
	* * *		
12	Control, Water Low Pressure	11-0296-00	1
	* * *		
13	O-Ring	03-1409-21	1
	* * *		
14	Cap, Freezer	13-0815-01	1

Figure 8-2. AF-330 - Major Assemblies (cont'd)

INDEX NO.	DESCRIPTION	PART NUMBER	REQ'D NUMBER
15	Spout Assembly (See Figure 8-4). * * *	No Number	1
16	Gasket, Spout attaching parts, Index 15 and 16 Lockwasher, No. 1/4 Internal Tooth - Phosphor Bronze Screw, No. 1/4-20 x 1 Soc-Hd Cap S/S * * *	13-0628-00 03-1417-07 03-1544-03	1 2 2
17	Freezer Assembly (See Figure 8-5) attaching parts, Index 17 Lockwasher, No. 5/16 External Tooth - Carbon Steel Zinc Plated Screw, No. 5/16 x 3/4 Hex Cap * * *	No Number 03-1417-12 03-1420-04	1 3 3
18	Coupling * * *	15-0575-01	1
19	Gasket * * *	13-0679-00	1
20	Drivemotor Assembly (See Figure 8-6) attaching parts, Index 20 Grommet Spacer Washer, Special Lockwasher, No. 1/4 Helical Spring Screw, No. 1/4-20 x 7/8 Hex Cap * * *	A28151-021 13-0639-00 A24925-001 03-1408-02 03-1410-03 03-1405-45	1 3 3 6 3 3
21	Grommet * * *	13-0768-01	1
22	Pad, Sealing * * *	13-0806-01	1

Figure 8-2. AF-330 - Major Assemblies (cont'd)

INDEX NO.	DESCRIPTION	PART NUMBER	REQ'D NUMBER
23	Storage Bin NOTE: See Figure 8-7 for replacement parts within the Control Box Assembly.	A28057-001	1

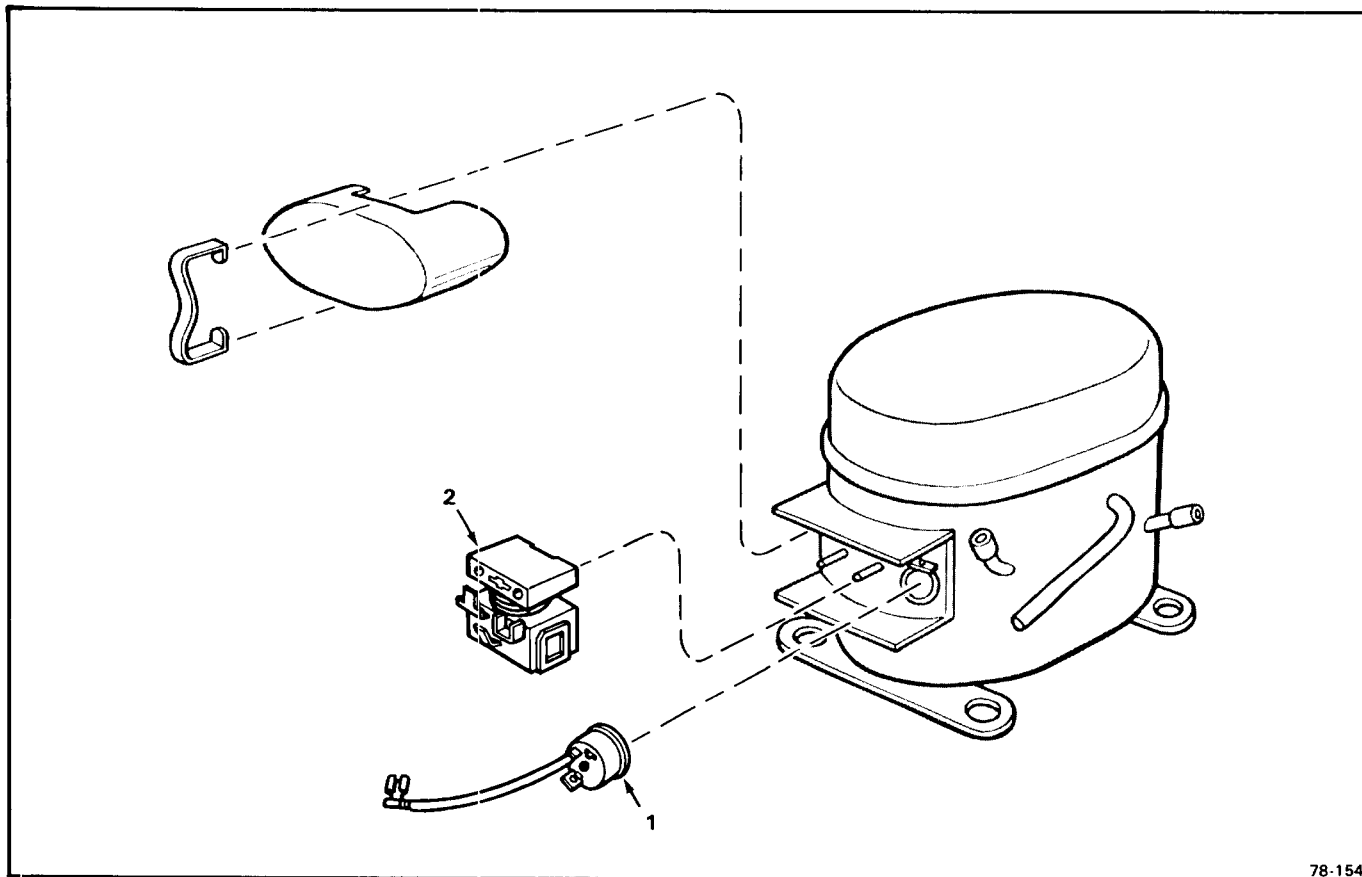

78-154

Figure 8-3. Compressor Assembly

INDEX NO.	DESCRIPTION	PART NUMBER	REQ'D NUMBER
	Compressor Assembly (Tecumseh) (See Figure 8-2/5 for next higher Assembly) * * *	18-4700-01	Ref.
1	Overload * * *	18-4700-20	1
2	Relay * * *	18-4700-30	1

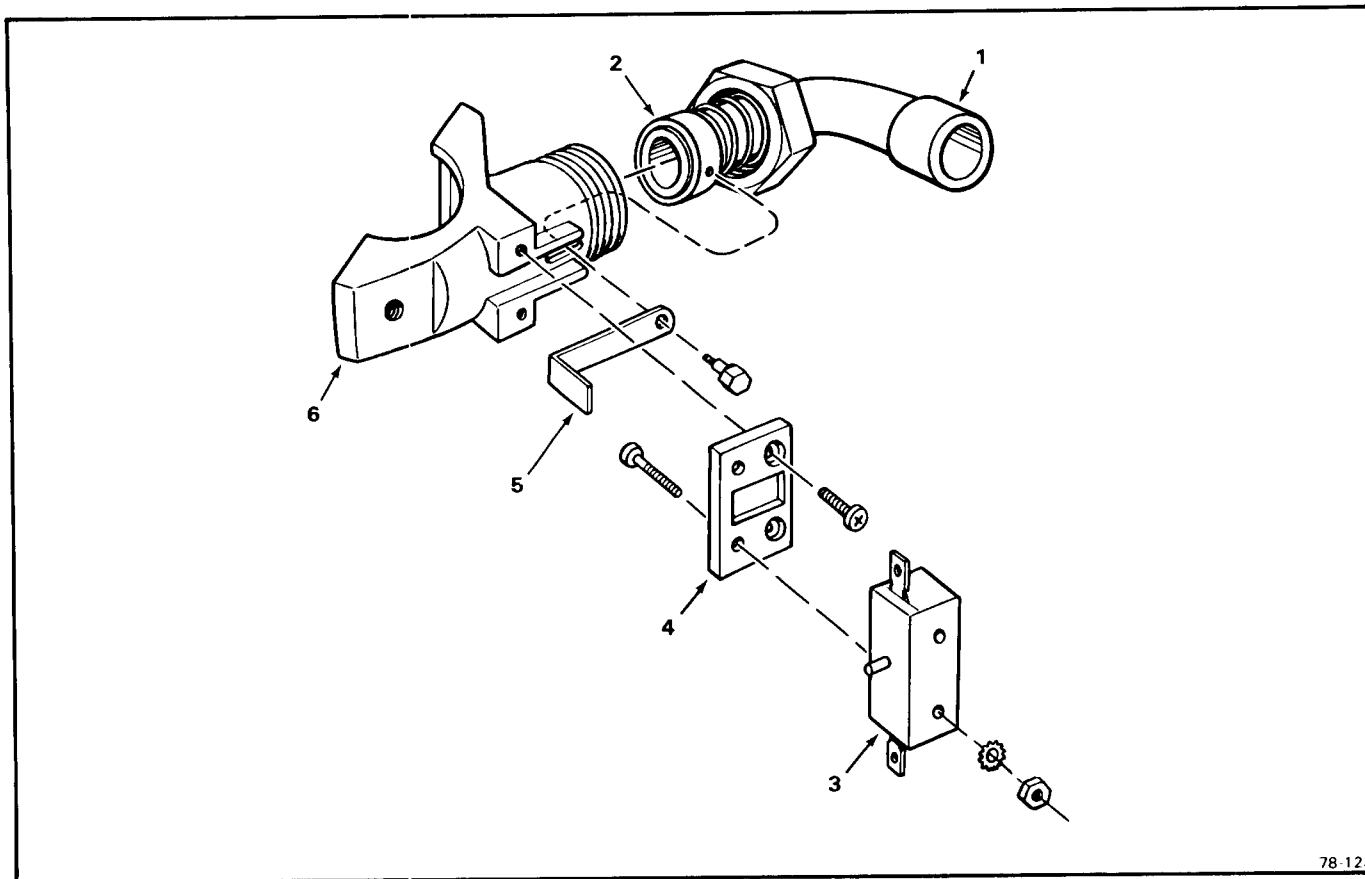

78.123

Figure 8-4. Spout Assembly.

INDEX NO.	DESCRIPTION	PART NUMBER	REQ'D NUMBER
	Spout Assembly (See Figure/Index 8-2/15 for next higher Assembly) * * *	No Number	Ref.
1	Tube, Ice Discharge * * *	A26542-001	1
2	O-Ring * * *	13-0617-41	1
3	Switch attaching parts, Index 3 to 4	12-1664-00	1
	Screw, No. 6-32 x 1 Flat Hd. Mach - Phil Recess	03-1418-38	2
	Lockwasher, No. 6 External Tooth - Phosphor Bronze	03-1417-01	2
	Nut, No. 6-32 Hex Mach Screw * * *	03-1406-01	2

Figure 8-4. Spout Assembly (cont'd)

INDEX NO.	DESCRIPTION	PART NUMBER	REQ'D NUMBER
4	Barrier, Thermal attaching parts, Index 4 to 6 Screw, No. 6-32 x 3/8 Flat Hd Mach - Phil Recess * * *	02-2377-01 03-1418-01	1 2
5	Actuator, Switch attaching parts, Index 5 to 6 Screw, Shoulder * * *	A27511-001 A25305-001	1 1
6	Spout * * *	A24934-001	1

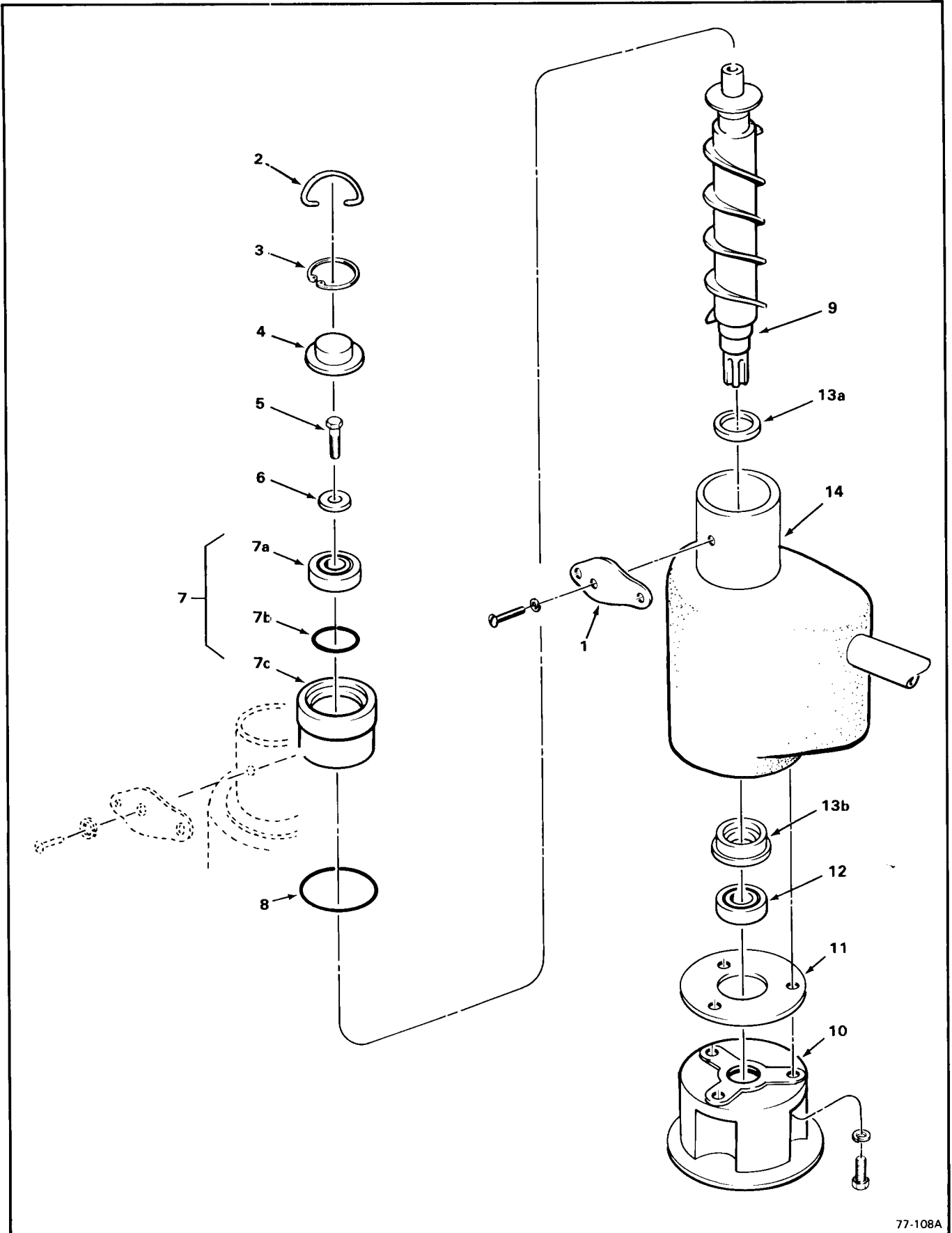

77-108A

Figure 8-5. Freezer Assembly

Figure 8-5. Freezer Assembly

INDEX NO.	DESCRIPTION	PART NUMBER	REQ'D NUMBER
	Freezer Assembly (See Figure/Index 8-2/17 for next higher Assembly) * * *	No Number	Ref.
1	Plate, Spout attaching parts, Index 1 Washer, No. 3/16 Non-Metallic Screw, No. 10-24 x 3/8 Phil Recessed Hd Sealing * * *	A18430-002 03-1409-14 03-1506-01	1 1 1
2	Hook, Cap * * *	A08162-000	1
3	Ring, Retaining * * *	03-1558-03	1
4	Cap * * *	A07701-000	1
5	Screw, Cap * * *	03-0758-00	1
6	Washer * * *	A07699-000	1
7	Bearing/Retainer - w/Bearing	A26707-001	1
7a	Bearing	03-0695-00	1
7b	O-Ring	13-0617-16	1
7c	Retainer, Bearing (Order P/N A26707-001) * * *	No Number	Ref.
8	O-Ring * * *	13-0617-29	1
9	Auger * * *	02-2451-01	1
10	Adaptor attaching parts, Index 10 Lockwasher, No. 5/16 Helical Spring	03-0595-01 03-1410-04	1 3

Figure 8-5. Freezer Assembly (cont'd)

INDEX NO.	DESCRIPTION	PART NUMBER	REQ'D NUMBER
	Screw, No. 5/16-18 x 7/8 Hex Cap * * *	03-1405-42	3
11	Gasket * * *	03-1505-00	1
12	Bearing * * *	03-0417-00	1
13	Seal, Water	A18945-000	1
13a	Seal, Upper (Fits on Index 9)	No Number	Ref.
13b	Seal, Lower (Fits on top of Index 12) * * *	No Number	Ref.
14	Freezer - (Repair Assembly) * * *	A28209-020	1

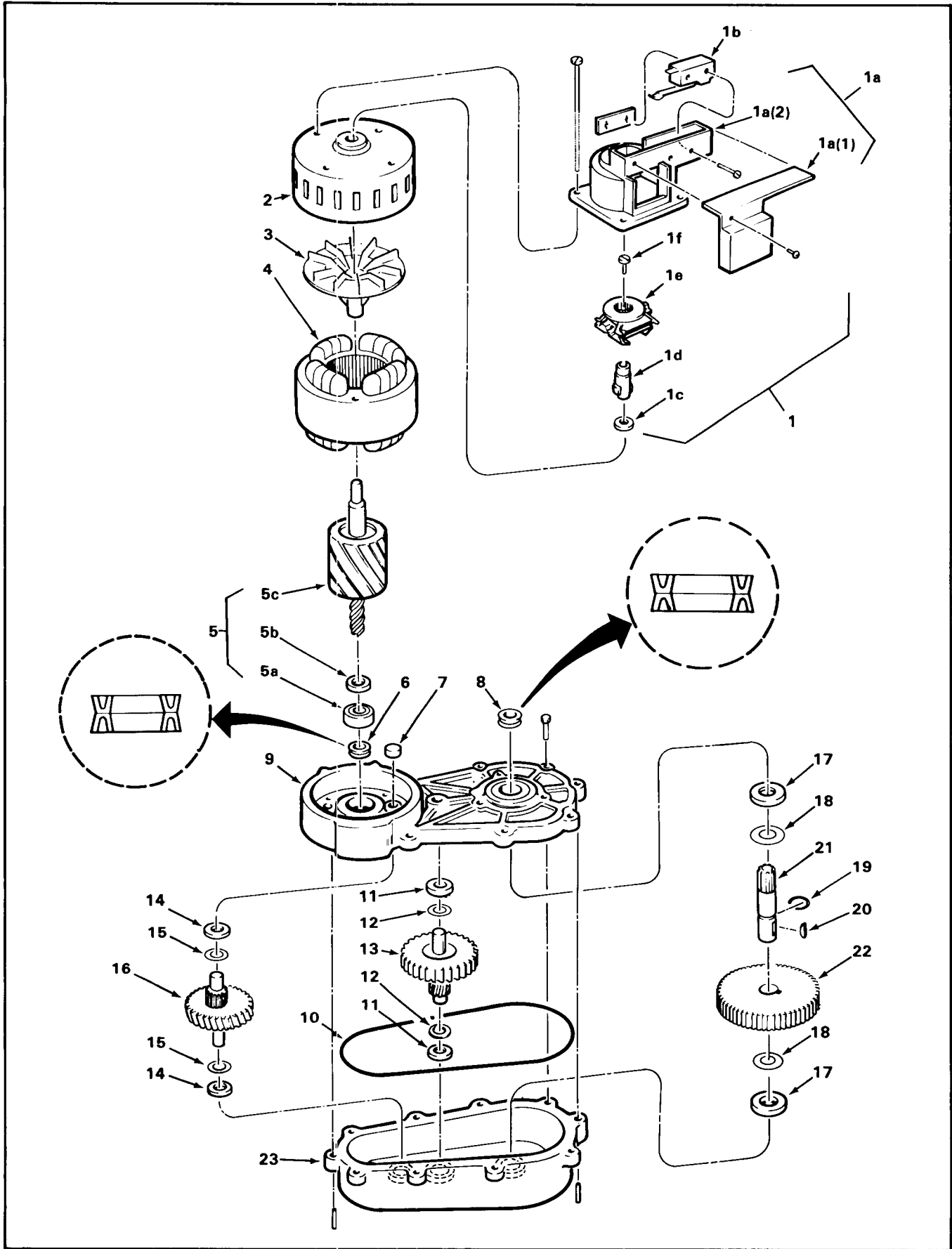

Figure 8-6. Drivemotor Assembly

Figure 8-6. Drivemotor Assembly

INDEX NO.	DESCRIPTION	PART NUMBER	REQ'D NUMBER
	Drivemotor Assembly (1/10 H.P.) (11.53 RPM) (See Figure/Index 8-2/20 for next higher Assembly) * * *	A28151-021	Ref.
1	Kit, Centrifugal Switch attaching parts, Index 1, 2, 4 to 11 Screw, Motor - No. 10-32 x 5-1/4 Phil Recess Pan Hd * * *	A27494-001	1
1a	Kit, Centrifugal Switch Housing	A27895-001	1
1a(1)	Cover, Switch Case	No Number	1
1a(2)	Case, Switch Mounting attaching parts, Index 1a(1) to 1a(2) Screw, No. 6-32 x 1 Pan Hd * * *	No Number	1
1b	Switch attaching parts, Index 1b to 1a(2) Screw, No. 6-32 x 1 Pan Hd Nut, Speed * * *	12-2059-01	1
1c	Washer, Special * * *	03-1403-09	2
1d	Extension, Shaft * * *	03-0886-00	2
1e	Actuator, Centrifugal attaching parts, Index 1d to 1e * * *	03-1408-36	1
1f	Screw, No. 10-32 x 1-5/8 Pan Hd * * *	02-2371-00	1
2	Housing Assembly - Motor * * *	12-2060-01	1
		03-1403-77	1
		A17047-001	1

Figure 8-6. Drivemotor Assembly (cont'd)

INDEX NO.	DESCRIPTION	PART NUMBER	REQ'D NUMBER
3	Fan, Boring attaching parts, Index 3 to 4 Setscrew * * *	A28168-001 03-1246-00	1 2
4	Stator Assembly (115/60/1) * * *	12-1400-01	1
5	Rotor Assembly	A28160-001	1
5a	Bearing	02-1501-00	1
5b	Washer, Special	03-1408-08	1
5c	Rotor (Order P/N A28160-001) * * *	No Number	1
6	Seal, Grease (Install back-to-back) * * *	02-1504-00	2
7	Cap, Insulating * * *	02-2459-01	1
8	Seal, Grease (Instalf back-to-back) * * *	02-1503-00	2
9	Cover Assembly, Gear Case attaching parts, Index 9 to 23 Pin, Roll Screw, No. 1/4-20 x 3/4 Flange Screw, No. 1/4-20 x 5/8 Flange * * *	A28165-001 03-0774-11 03-1252-00 03-1251-00	1 2 2 6
10	O-Ring * * *	02-1505-00	1
11	Washer, Special (Thick) * * *	03-1408-39	2
12	Washer, Special (Thin/Shim) * * *	03-1408-40	A/R
13	Third Pinion Assembly, Second Gear and * * *	02-2439-01	1

Figure 8-6. Drivemotor Assembly (cont'd)

INDEX NO.	DESCRIPTION	PART NUMBER	REQ'D NUMBER
14	Washer, Special (Thick) * * *	03-1408-41	2
15	Washer, Special (Thin/Shim) * * *	03-1408-38	A/R
16	Second Pinion Assembly, First Gear and * * *	02-2438-01	1
17	Washer, Special (Thick) * * *	03-1408-21	2
18	Washer, Special (Thin/Shim) * * *	03-1408-04	A/R
19	Ring, Retaining * * *	03-1515-03	1
20	Key, Woodruff * * *	03-1602-01	1
21	Shaft, Output * * *	02-2445-01	1
22	Gear, Output * * *	02-2444-01	1
23	Case Assembly, Gear * * *	A28166-001	1

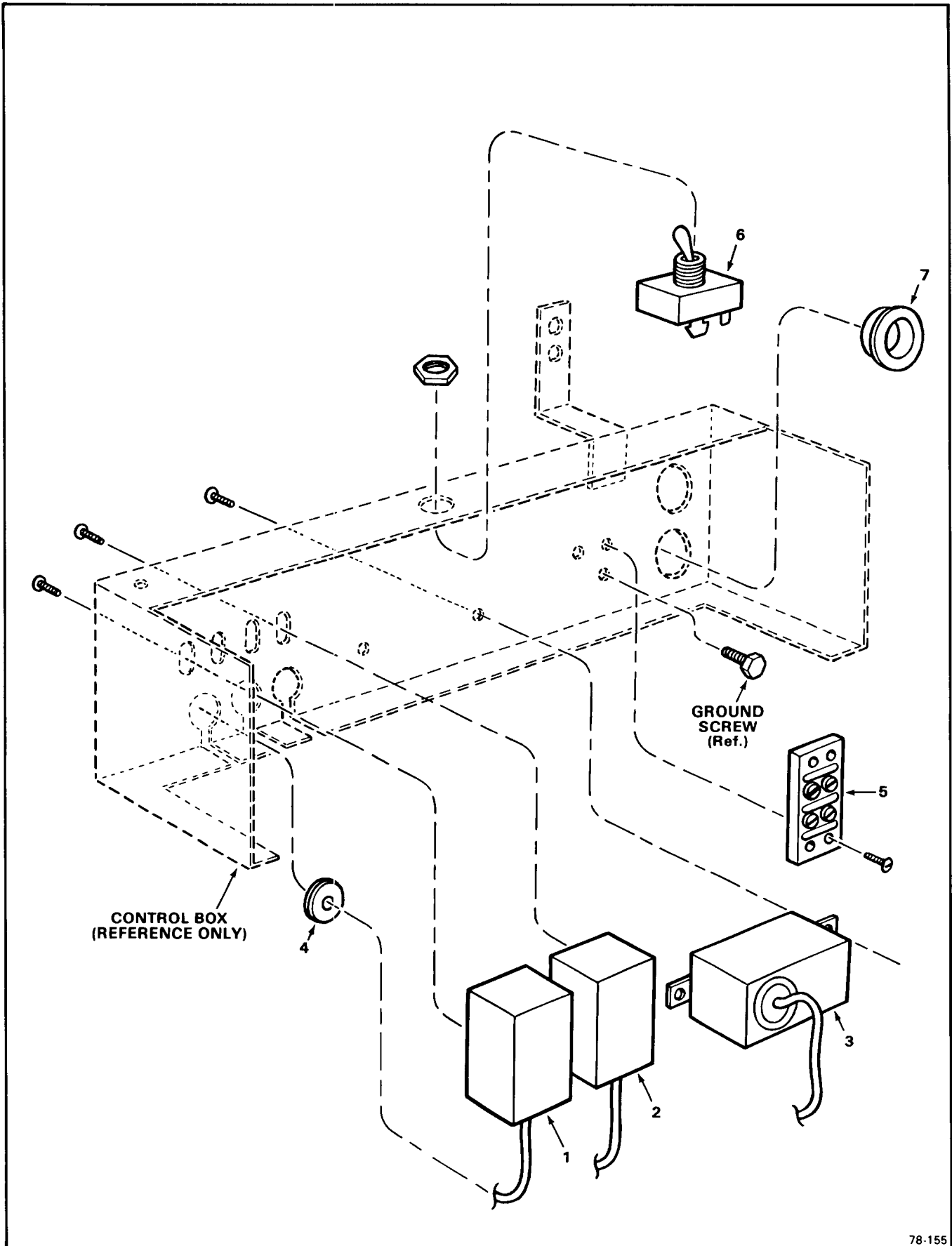

78-155

Figure 8-7. Control Box Assembly

Figure 8-7. Control Box Assembly

INDEX NO.	DESCRIPTION	PART NUMBER	REQ'D NUMBER
	Control Box Assembly (See Figure 8-2 for next higher Assembly) * * *	No Number	Ref.
1	Control, Low-Pressure attaching parts, Index 1 Screw, No. 6-32 x 1/4 Pan Hd * * *	11-0358-01 03-1403-02	1 2
2	Control, Pressure attaching parts, Index 2 Screw, No. 6-32 x 1/4 Pan Hd * * *	11-0402-01 03-1403-02	1 2
3	Control, Bin Thermo attaching parts, Index 3 Screw, No. 8-32 x 3/16 Pan Hd * * *	11-0354-00 03-1403-14	1 2
4	Grommet * * *	13-0557-00	3
5	Board, Terminal attaching part, Index 5 Screw, No. 8-32 x 3/4 Pan Hd * * *	12-0813-04 03-1403-21	1 2
6	Switch, Toggle * * *	12-0426-01	1
7	Bushing, Snap * * *	12-1213-10	1

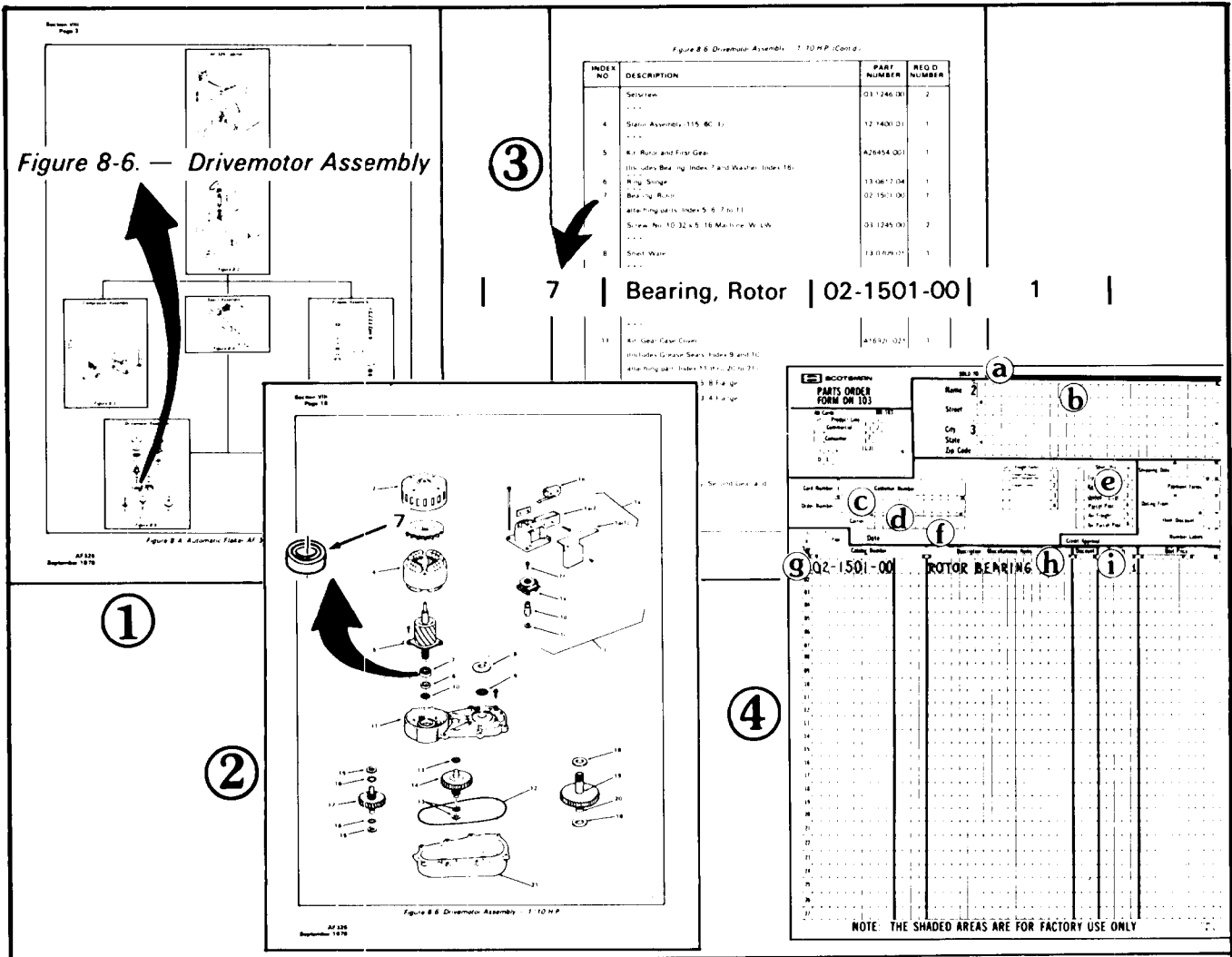

HOW TO USE A SCOTSMAN PARTS MANUAL WHEN ORDERING PARTS FOR ICE SYSTEMS PRODUCTS

IMPORTANT A. All Part Numbers have TEN DIGITS (spaces), required for use in the Computer System. BE SURE to fill in ALL SPACES in the CATALOG NUMBER column, on the Parts Order form as shown above.

B. Enter the QUANTITY of the Parts ordered, in the last digit column under the QUANTITY column heading, the one under the small 55 number, for parts from 1 thru 9. For 10 or more parts use two columns.

To be sure you receive the proper parts in the proper quantities, ALWAYS use the PART NUMBERS and DESCRIPTIONS given in the Parts Manuals.

The figures above illustrate the way a Parts Manual would be used, if the Part being ordered were the ROTOR BEARING that is used in the DRIVEMOTOR ASSEMBLY of an AF325 Automatic Flaker, for example.

PROCEDURE:

1. At the beginning of Section VIII, THE PARTS ILLUSTRATIONS AND PARTS LISTS, in each Parts and Service Manual, is Figure 8-A; which, is a flow chart prepared from exploded views in Section VIII. Use the flow chart to quickly determine which Figure contains the Assembly, Component or Part.

FIGURE 1: Since the Part required in the above example is in the DRIVEMOTOR ASSEMBLY, shown as FIGURE 8-6.

2. Open the Manual to page showing FIGURE 8-6.

3. Locate the PART and its INDEX NUMBER on the exploded view illustration.

FIGURE 2: The INDEX NUMBER for the PART is 7.

4. Check the numerical sequence in the associated Parts List following the illustration.

5. LOCATE the INDEX NUMBER 7, in the INDEX NO. column, the first column on the left side of the Parts List page.

FIGURE 3: INDEX NO. 7 is listed as a BEARING, ROTOR in the DESCRIPTION column. The Part Number for the Rotor Bearing is 02-1501-00 as listed in the PART NUMBER column on the right side of the Parts List page. And, one Rotor Bearing is listed in the REQ'D NUMBER column, or that ONLY one of those parts is required for one Drivemotor Assembly.

6. Write an order for the Part. (Use SCOTSMAN Parts Order Form DN103)

- FIGURE 4:**
- a. Distributor Name.
 - b. (Use for DROP-SHIP order ONLY).
 - c. Distributor Purchase Order Number.
 - d. Carrier
 - e. How shipped (Truck, Rail, UPS, etc.)
 - f. Date ordered
 - g. Part Catalog Number (use full TEN digits (spaces) listed in Parts Manual, including dashes between numbers.)
 - h. Description - as listed in Parts Manual.
 - i. Quantity - number of parts ordered. (use far right column)

Figure 8-00. How To Use The Illustrated Parts List.