

# **TECH - SPEC'S Technician's Handbook**

## **#80050B**

This technicians handbook has 2 sections. The first section covers general information for all Hoshizaki H-Series cuber ice maker models. Additional technical information, full parts, and service manuals are available for review and download on the Tech Support page of the Hoshizaki web site.

The second section covers F/DCM auger products.

See “[www.hoshizakiamerica.com/support](http://www.hoshizakiamerica.com/support)” for manuals, Tech- Tips, and additional technical information on Hoshizaki products.

See Tech-Spec's #80024 purple pocket guide for older models using R-12/502 refrigerant.

See Tech-Spec's #80021 green pocket guide for E-Series models using R-22.

See Tech-Spec's #80045 orange pocket guide for F and early H series ice maker models.

These guides can be downloaded from the Hoshizaki web site or purchased through your local Hoshizaki Distributor. A print out of the guides will be on a 3.5 x 7 format. Set printing preference if larger format is needed.

**FOR FACTORY SUPPORT  
CONTACT HOSHIZAKI TECHNICAL SUPPORT AT:  
1-800-233-1940**

**E-Mail: [techsupport@hoshizaki.com](mailto:techsupport@hoshizaki.com)**

# TABLE OF CONTENTS:

PAGE

<b>Model Number Identification Code</b> .....	8
<b>Serial Code</b> .....	9
<b>Nameplate</b> .....	10
<b>Warranty Information</b>	
Registration.....	11
Coverage.....	11
<b>KM Installation</b>	
General Specs.....	12
Plumbing Requirements (All).....	12
Condensate Drain.....	13
Flow Rates (KM).....	14
Filtration.....	14
Electrical Connections.....	15
Transformer Application (optional).....	16
<b>Remote Applications</b>	
Condenser Chart.....	17
Remote Lines.....	18
Line Set Application Chart.....	18
Remote Cond. Installation Diagram.....	19
Line Set Installation .....	20
Connectors.....	21
<b>R-404A Refrigerant System Information</b>	
System Charge.....	22
Cuber Charge Chart.....	23
URC Charge Chart.....	27
Refrigerant Oil.....	27
Heat Load for AC & Cooling Tower.....	28
Cuber Heat Load Chart.....	28
Condenser Heat Load Chart.....	30
<b>Component Technical Data</b>	
“E” Control Board Adjustment Guide.....	31
“E” Board Dip Switch Settings.....	32
“G” & “H” Board Adjustment Guide.....	33
“G” Board Dip Switch Settings.....	35
Positive Harvest Feature .....	38
“H” Board Dip Switch Settings.....	38
“E” Control Board Functions.....	39
Manual Reset Safeties.....	40
“E” Control Board Label.....	41
“G” Control Board Label.....	42
“H” Control Board Label.....	43
“H” Board Dip Switch Designation.....	44
Compressor Data.....	45
Water-Cooled Head Pressure Controls.....	52
Remote Head Pressure Controls.....	53
High Pressure Safety Switch.....	54
Pressure Switch Chart.....	54
Bin Control - Thermostatic.....	54
Bin Control Extensions.....	56
Mechanical.....	58

	PAGE
<b>KM Cuber Sequence of Operation</b> .....	60
Basic KM Sequence Flow Chart.....	62
KM-251/255 BAH/BWH Sequence Flow Chart.....	63
KM-61~260B & KMD Sequence Flow Chart.....	64
KMS-750~1401MLH Sequence Flow Chart.....	65
KM-10 Minute Check Out.....	66
“G” Board 15 Minute Check Out.....	68
Reservoir Flush System	
Pump-Out Check Valve.....	70
KML Pump-Out.....	70
KM 61/101/151 Drain Cycle.....	71
KM Control Switch.....	72
Control Board Fuse.....	72
Control Board Fuse Label.....	73
<b>Component Checks</b>	
Float Switch.....	74
Thermistor.....	77
Control Board.....	77
Board Checkout.....	78
Bin Control - Thermostatic.....	79
Mechanical.....	80
KM Control Transformer.....	82
Pump Assemblies - KML.....	82
Smaller KM's.....	83
Larger KM's.....	84
Refrigeration Solenoid Valves.....	84
Inlet Water Valve.....	85
CKD Valves.....	86
Invensys, EATON, and other Valves.....	87
Water Valve Coil.....	87
KMS Serenity.....	88
KM Evaporator.....	89
<b>Diagnosing Water Problems</b> .....	91
Freeze Up Check List.....	93
Preventative Maintenance.....	95
Cleaning/Sanitizing Procedure.....	96
KM Production Check.....	98
<b>Cuber Water/Refg Circuit Reference Chart</b> .....	99
<b>Performance Data - Cuber</b>	
AM-50BAE.....	121
KM-61BAH.....	122
KM-101BAH.....	123
KM-151B_H.....	124
KM-201B_H.....	125
KML-250M_H.....	126
KM-251BAH.....	127
KM-255BAH.....	128
KM-260B_H.....	129
KM-280M_H.....	130
KM-280MAH-E.....	131

	PAGE
KM-320M_H.....	132
KM-320MAH-E.....	133
KML-350M_H.....	134
KML-351M_H.....	135
KMD-410M_H.....	136
KML-450M_H.....	137
KMD-450M_H.....	138
KML-451M_H.....	139
KMD-460M_H.....	140
KM-461M_H.....	141
DKM-500B_H.....	142
KM-500MAH-E.....	143
KM-501M_H.....	144
KM-515M_H.....	145
KM-515MAH-E.....	146
KM-600MAH.....	147
KML-600M_H.....	148
KML-600MWH Serial L0-M1.....	149
KM-630M_H.....	150
KM-630MAH-E.....	151
KML-631M_H.....	152
KM-650M_H.....	153
KM-650MAH-E.....	154
KMD-700M_H.....	155
KMS-750MLH & SRK-7H.....	156
KMS-822MLH & SRK10H.....	157
KMS-830MLH & SRK8H & H3.....	158
KMD-850M_H.....	159
KM-900M_H.....	160
KM-900MRH3.....	161
KM-900MAH-50.....	162
KMD-900M_H.....	163
KM-901M_H.....	164
KM-901MRH3.....	165
KMD-901M_H.....	166
KMS-1122MLH & SRK8H & H3.....	167
KMS-1230MLH & SRK-13H.....	168
KM-1300M_H.....	169
KM-1300S_H.....	170
KM-1300S_H3.....	171
KM-1300SAH-E.....	172
KM-1301S_H.....	173
KM-1301SAH-E.....	174
KM-1301S_H3.....	175
KM-1340M_H.....	176
KM-1400SWH-M & 3.....	177
KMS-1400MLH & SRK-14H.....	178
KMS-1401MLH & SRK-14H & H3.....	179

	PAGE
KMS-1401MLJ & SRK-14J & J3.....	180
KM-1600MRH.....	181
KM-1600MRH3.....	182
KM-1600S_H.....	183
KM-1600S_H3.....	184
KM-1601MRH.....	185
KM-1601MRH3.....	186
KM-1601S_H.....	187
KM-1601S_H3.....	188
KM-1800S_H.....	189
KM-1800S_H3.....	190
KM-1900S_H.....	191
KM-1900S_H3.....	192
KM-2000S_H3.....	193
KMH-2000S_H3.....	194
KMS-2000MLH & SRK-20H & H3.....	195
KM-2100S_H3.....	196
KM-2400SRH3.....	197
KM-2500S_H3.....	198
10-Pin Board Connector.....	199
<b>Wiring Diagram Reference Chart.....</b>	<b>200</b>
<b>Remote Condenser Capacitor Chart.....</b>	<b>206</b>
Mechanical Bin Control w/Resistor Harness.....	207
KM Wiring Harness.....	252
<b>F/DCM Products Section.....</b>	<b>253</b>
<b>Nameplate.....</b>	<b>255</b>
<b>Warranty Information</b>	
Registration.....	256
Coverage.....	256
<b>F/DCM Installation</b>	
General Specs.....	257
Plumbing Requirements (All).....	257
Drain .....	258
Flow Rates.....	259
Filtration.....	259
General Installation.....	260
Cubelet on Dispenser.....	260
<b>Remote Applications</b>	
Condenser Chart.....	261
Use of Non-OEM Condensers .....	261
Remote Lines (F/FD/FS).....	262
Line Set Application Chart .....	262

<b>R-404A Refrigerant System Information</b>	PAGE
Flaker/DCM Charge Chart.....	263
Heat Load for AC & Cooling Tower.....	264
Flaker & DCM Heat Load Chart.....	265
<b>Component Technical Data</b>	
Compressor Data.....	266
Water-Cooled Head Pressure Controls .....	269
High Pressure Safety Switch .....	270
Pressure Switch Chart.....	270
Bin Controls.....	271
Flaker Control Boards.....	273
F-A Control Board.....	274
F-A Dip Switch Settings.....	276
F-A Board Label.....	277
F-A Board Voltage.....	278
DCM Control Boards.....	279
Control Switches.....	280
Evaporator Barrel Heaters.....	280
Control Transformer.....	281
Gear Motor protection.....	281
Internal Auger Design.....	282
Flaker Sequence of Operation.....	283
DCM Sequence of Operation.....	284
Flaker Timer Board.....	285
Flaker Fill System.....	286
Flaker Sequence Flow Chart.....	287
F-A Board Sequence Flow Chart.....	289
DCM Sequence Flow Chart.....	291
F-A Board in DCM Flow Chart.....	293
<b>Component Checks</b>	
Dual Float Switch.....	295
Gear Motor Checkout.....	298
Seal Bolts .....	299
Auger Bearings.....	301
Mechanical Seal.....	302
Water Solenoids.....	303
Auger Inspection/Bearing Replacement.....	304
F/DCM Production Check.....	305
<b>Diagnostic Tips</b>	
Water System.....	309
Electrical System.....	309
Refrigeration System.....	310
Leaks.....	310
TXV.....	310
Evaporator frost Test.....	311
<b>Maintenance</b>	
Preventative Maintenance.....	306
Cleaning /Sanitizing Procedures.....	307

	PAGE
<b>Flaker/DCM Water/Refg Drawing</b>	
Drawing Reference Chart.....	312
<b>Performance Data - Flaker/DCM</b>	
C-100BAH.....	331
DCM-270BAH (-OS).....	332
DCM-500B_H(-OS).....	333
DCM-750B_H-OS.....	334
DCM-751B_H-OS.....	335
F-300BAF.....	336
F-330BAH.....	337
DT-400BAH-OS.....	338
F-450MAH-C.....	339
F-500BAF(-C).....	340
FD-650M_H(-C).....	341
F-800M_H.....	342
F-800M_H-C.....	343
F-801M_H.....	344
F-801M_H-C.....	345
F-1001M_H.....	346
F-1001M_H-C.....	347
F-1001M_J.....	348
F-1001M_J(-C).....	349
F-1001MLH (-C).....	350
FS-1001MLH-C.....	351
FS-1022MLH-C.....	351
F-1500M_H.....	352
F-1500M_H-C.....	353
F-1501M_H.....	354
F-1501M_H-C.....	355
FS-1501MLH-C.....	356
F-2000M_H(3).....	357
F-2000M_H-C.....	358
F-2001M_H(3).....	359
F-2001MRH-C.....	360
F-2001MLH (-C).....	361
<b>Flaker/DCM Wiring Diagram Reference Chart.....</b>	<b>362</b>
<b>Notes.....</b>	<b>394</b>

# **HOSHIZAKI MODEL NUMBER:**

## **ID Code - Designation example KM-1301SAH-E**

### **KM - UNIT TYPE**

- AM - "Top Hat" Cuber
- B - Bin
- BD - Bin for 24" depth models
- DB - Dispenser Bin
- DCM - Dispenser Cubelet Maker
- DKM - Dispenser KM Combo
- DM - Counter Top Dispenser
- DT - DCM/F-C Combo
- F - Flaker
- FD - Dispenser Model (24" deep)
- FS - Flaker-C Serenity
- HCD - Bagger Bin
- KM - Crescent Cuber
- KMD - Dispenser model (24" deep)
- KMH - High Capacity KM
- KML - Low Profile Crescent Cuber
- KMS - KM Serenity
- URC - Standard Remote Condenser
- SRK - Serenity KM Condensing Unit

### **1300 - PRODUCTION**

- Approximate production/24 Hours
- @ 70°F Air/50°F Water

### **S - UNIT STYLE**

- B - Self contained with bin
- M - Modular
- S - Stackable

### **A - CONDENSER STYLE**

- A - Air Cooled
- L - Low Side
- R - Remote Air Cooled
- W - Water Cooled

### **H - GENERATION/SERIES**

- Model designation H - R404A latest model

### **E - SPECIAL MODEL DESIGNATION**

- 50 - 50 HZ.
- C - Cubelet
- E - European - 50 HZ.
- OS - Opti-Serve



## Serial Code:

Standard serial number is letter, 5 digits, letter.

Example: D10041A

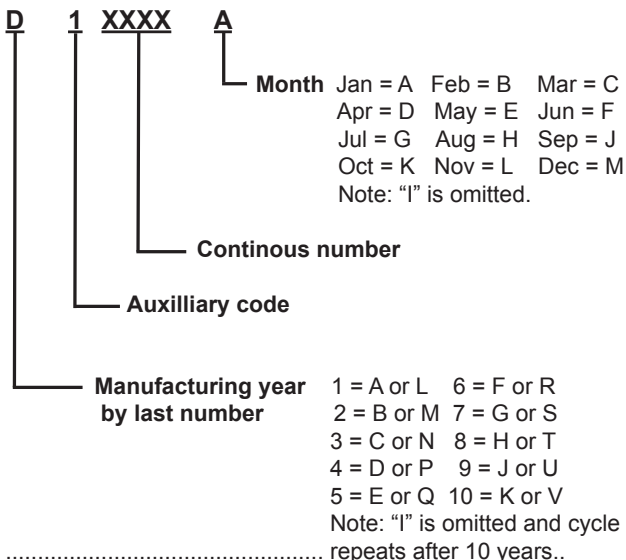

**Example: A10005F was produced in June of 2011,  
B20103B was produced in February 2012,  
C50332M was produced in December 2013.**

## QR Code:



A QR code has been added to icemakers produced in Peachtree City, GA from 2012 with B serial numbers and to future service literature. You will find the QR code label in the compressor compartment of the unit. Scan the code with your smart phone for instant technical information. Ice maker code is model /serial specific and opens a warranty registration page with technical manuals. Service literature Code will open this Tech Support web page.

# Model Nameplate:

## HOSHIZAKI ICE MAKER

MODEL NUMBER	KM-650MAH
SERIAL NUMBER	
AC SUPPLY VOLTAGE	208-230/60/1 (3 WIRE WITH NEUTRAL FOR 115V)
COMPRESSOR	208-230V 6.0RLA 36LRA
PUMP	120V 0.5FLA 10W
FAN	120V 1.0FLA 30W
OTHER	115-120V 0.15A
MAXIMUM FUSE SIZE	15 AMPS
MAX. HACR BREAKER (USA ONLY)	15 AMPS
MAX. CIRC. BREAKER (CANADA ONLY)	15 AMPS
MINIMUM CIRCUIT AMPACITY	15 AMPS
DESIGN PRESSURE	HI - 467PSI LO - 230PSI
REFRIGERANT	404A 1 LB. 8 OZ.

**MOTOR-COMPRESSOR THERMALLY PROTECTED,  
NOT INTENDED FOR OUTDOOR USE!**

**Hoshizaki America, Inc.**  
Peachtree City, GA  
[www.hoshizaki.com](http://www.hoshizaki.com)



See the Nameplate for electrical and refrigeration specifications. This Nameplate is located on the upper right hand side of rear panel. Since this Nameplate is located on the rear panel of the ice maker, it cannot be read when the back of the ice maker is against a wall or another piece of kitchen equipment. Therefore, the necessary electrical and refrigeration information is also on the rating label, found by removing the front panel of the ice maker. We reserve the right to make changes in specifications and design without prior notice.

## Warranty Information:

### Registration:

Warranty registration is available online and a registration card is supplied with the equipment. Registration must be completed to initiate warranty. The warranty begins on the date of installation if registration procedures are followed. If registration is not completed, the warranty date will be the date of sale or date of shipment from the factory, respectively.

### Warranty Coverage:

The warranty will cover defects in material or workmanship under normal and proper use and maintenance service as specified by Hoshizaki. Coverage for parts and labor is limited to the repair or replacement of parts or assemblies that in Hoshizaki's opinion are defective.

### Coverage Chart:

ITEM	PRODUCT	PARTS	LABOR
Total Unit	AM-50B	2 Years	2 Years
	C-101B	2 Years	2 Years
	Standard Bin from Jan 2012	3 Years	3 Years
	DB/DM	3 Year	3 Year
	F/DCM from Sep 2010	3 Years	3 Years
	All KM Cuber Upright Bin	3 Years 5 Years	3 Years 5 Years
Compressor & Air-Cooled Cond Coil	KM Cuber F/DCM	5 Years	3 Years
		5 Years	3 Years
Evaporator Plate	KM Cuber	5 Years	5 Years
Evaporator, Auger Gear Motor Assy.	F/DCM	3 Years	3 Years
Accessory	Drain Pump	1 Year	---
	Other	90 Days	---

See Warranty Statement supplied with the unit for details. Warranty valid in United States, Canada, Mexico, Puerto Rico, and U. S. Virgin Islands.

Contact factory for warranty in other countries, territories, or possessions.

## KM Installation General Specs:

The ice machine is not intended for outdoor use.

Operating Conditions - ALL MODELS

Item	Model	Range
Voltage Range	115V units	104~127V
	208-230V units	187~264V
	220-240 or 230V	198~254V
Ambient Temp.	All	45~100 °F
	Remote Con-denser	-20~122 °F
Water Supply Temp.	All	45~90 °F
Water Supply Pressure	All	10~113 PSIG

In general, allow 6" clearance at rear, sides, and top for proper air circulation and ease of maintenance or service.

## Plumbing Requirements:

**Water Supply:** On KM units, the water supply line size and flow rate is critical due to the water assisted harvest and the use of a ported inlet water valve solenoid.

Model	Line Size	Fitting Size
KM-61 ~ KM-901	1/4" Nominal ID	1/2 FPT
KML/KMD/KMS	1/4" Nominal ID	1/2 FPT
KM-1301 ~ KM-2500	3/8" Nominal ID	1/2 FPT

\*Nominal copper water tubing or equivalent. **ID Not OD!**

\* Note that small connection fittings can restrict water flow.

\*Water cooled condenser units require two separate supplies, sized as per list above.

## Drain Connections:

Model	Line Size	Fitting Size
All Bins	3/4" OD	3/4 FPT
All KM models	3/4" OD	3/4 FPT

\*Some models have 2 drain outlets.

\* Drain lines should never be sized smaller than the factory recommendation. Under sized drains can cause water backup and result in water damage.

**Water Cooled Condenser Outlet:**

KM-151BWH, KM-201BWH, KM-260BWH, KM-1301SWH, KM-1601SWH, KM-1601SWH3, KM-1900SWH, KM-2100SWH3, KM-2500SWH3 have 1/2" FPT outlet.

All other KM, KML, KMD models have 3/8" FPT outlet.

Hoshizaki recommends that the ice machine drain and bin drain be piped separately to the drain connection point allowing 1/4" per foot fall.

**Condensate Drain:**

The condensate drain is generally connected to the ice machine drain for simplicity. It can be piped separately to the drain exit if desired.

A 6" vent tee, as shown in the drawing, is recommended:

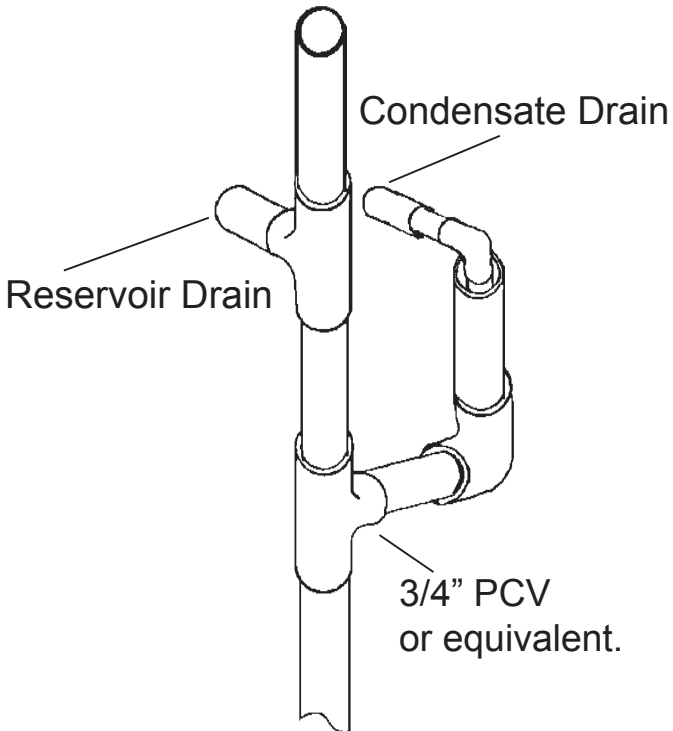

**Note:** Restricting the drain size will cause water to overflow the reservoir or drain pan!

## Flow Rates:

The minimum flow rate requirements for Hoshizaki KM ice maker units are as follows:

Models	GPM
KM-61/101/151/255	0.26~0.32
KM-201B/251B/260B/320M, KML-351MWH, KML-451M	0.53
DKM-500B, KML-250/350/450/631, KML-351MAH, KM-461/501/901M All F/DCM's	0.8
KM-515M-E/650M-E, KMD-410M	1.06
KMD-450/700/900M, KML-600M, KM-500M, KM-515M	1.58
KM-600/630/650/900/1340/1601M, KM- 900M50, KM-630M-E, KMD-850M/901M, KMS-750/1230/1300/1400	2.11
KMS-1122/1401M	2.38
KM-1601S/1801S/1900S/2100S/2500S	2.91
KM-1800S/2000S/2400S	3.34
KM-1300S/1600S, KM-1300S-E, KM-1301S, KM-1301S-E, KMS-2000M	3.96

## Filtration:

Hoshizaki recommends that filtration be installed on our products. The type of filtration will vary with local water quality. In some cases, treatment is needed to address water hardness, or high mineral content. The filtration systems provided by Hoshizaki are considered basic filtration with minimal water treatment capabilities.

There are many possibilities for water treatment: In general, a filter median is used for sediment/dirt and trash. Carbon is used for taste and odor and poly phosphate is used for scale control. There are also other possibilities, such as a water softener or in some cases, reverse osmosis (RO). RO can be aggressive, but is acceptable if the RO output has a neutral pH of 7.

Contact your local Hoshizaki distributor, or a water expert, for the best recommendation for your area.

**Note:** Filtration or treatment, must be sized and applied properly to be effective. Inadequate flow rate will cause problems with production and operation of the ice maker.

# Electrical Connections:

## 115 VOLT/1 PHASE

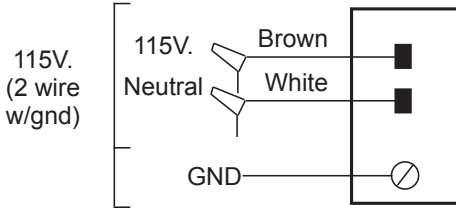

## 208-230 VOLT/1PHASE

208-230V/1 Phase units require a dedicated neutral due to the use of 115V components.

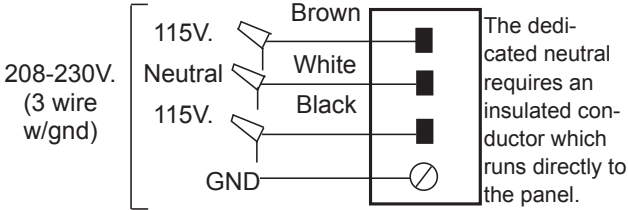

If high leg is present, connect to black wire. A transformer can be used to provide 115V control circuit.

**\*Beginning Dec. 2013, some models include the transformer and are noted as 3 Wire on the carton label. They require a 3 wire circuit... No dedicated neutral.**

## 208-230 VOLT/3 PHASE

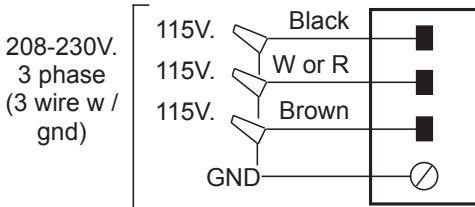

## URC Condenser Connections

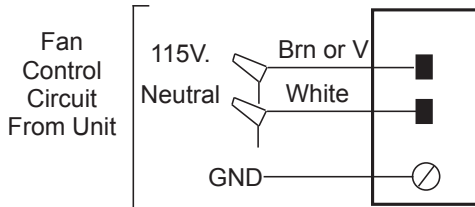

**Note:** All Electrical connections must be made in accordance with all national and local electrical codes.

## Transformer Application (Optional):

All 208V-230V 3 ph models include a 115V power transformer with a 208/230V selector switch. **Be sure to select the position that best matches the incoming voltage prior to supplying power to the unit.** (Voltage from the center tap to case ground will be 67.5V due to the transformer circuit.) 208/230V models include 115V controls and require a 115/208-230V circuit which has 4 wires: L1, L2, dedicated neutral, and ground.

If a dedicated neutral is not available, a step-down transformer can be used at the unit to provide power to the 115V components saving installation time and cost if a dedicated neutral is not present. Transformer #4A0817-01 or equivalent can be used for KM models. The transformer should be mounted inside the compressor compartment and wired using the following generic diagram.

**Beginning Dec. 2013, some models include the transformer and are noted as 3 Wire on the carton label. They require a 3 wire circuit... No dedicated neutral.**

*Note: Transformer 4A0817-01 has 4 wires...  
Connect Unit L1 to incoming L1 if using 446240-01 transformer.*

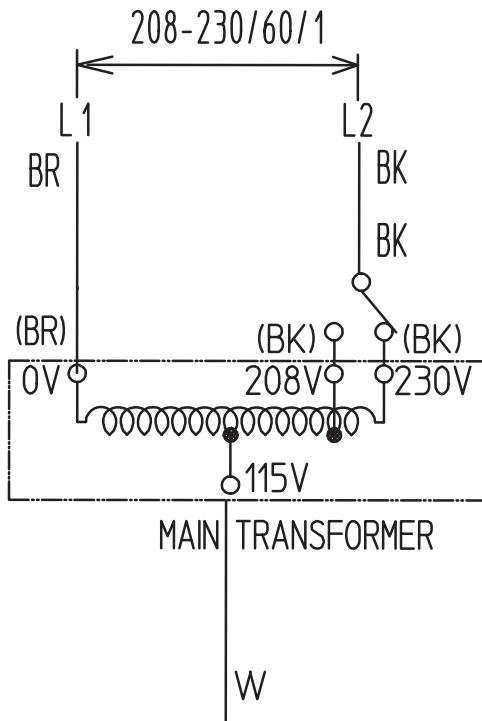



## Remote Applications: Condenser Chart

Condenser Model	Remote Model Number's
URC-5F	KM-461/515M/650M, *F-1001M, FD-1001M
URC-9F	KML-631M, KMD-850/901M
URC-14F	KM-1301S, KM-1340M, F-1500/1501M
URC-22F	KM-1601M/S, KM-1900S, KM-2100S, F-2000/2001M
URC-23F	KM-2500S
SRC-10H	FS-1001MLH
SRC-14H	FS-1500MLH
SRK-7H	KMS-750MLH
SRK-8H/H3	KMS-830MLH
SRK-10H	KMS-822MLH
SRK-12H/H3	KMS-1122MLH
SRK-13H	KMS-1230MLH
SRK-14H/H3	KMS-1400/1401MLH,
SRK-14J	KMS-1401MRJ
SRK-20H/H3	KMS-2000MLH
<b>Out of production:</b> URC-6F, URC-7F, URC-12F, URC-20F, URC-21F, URC-24F	

When installing a remote application the unit/condenser combination must match with the above chart. A non-OEM multi-pass condenser can be used with prior written factory approval. See service bulletin SB99-00019R1.

For out of production models, parts are available. Check unit manual on web for proper model match and parts info.

## Remote Lines:

Hoshizaki has 3 precharged line set lengths available: 20 ft, 35 ft, and 55 ft. The line sets are available in different sizes for different models.

Line Set Identification Code ex. R404 - 35610

R404 - Refrigerant

35 - Length In Feet

6 - Liquid Line Size in 16th's

10 - Discharge Line Size in 16th's

## Line Set Applications

Models	Line Set	LL-DL (Size)
KM-461/500/515/650MRH, KML-600	R404-2046-2 R404-3546-2 R404-5546	1/4" OD-3/8" OD
KM-900/901MRH, KM-1300/1301/1340M/S, KML-631MRH, KMD-700/850/900/901MRH,	R404-2068-2 R404-3568-2 R404-5568-2	3/8" OD-1/2" OD
KM-1600/1601M/S/3 KM-1800/1900/2000S/3 KM-2100S/3 KMH-2000SRH(3) KM-1800SRH(3) KM-2400SRH/(3) KM-2500SRH3	R404-20610 R404-35610 R404-55610	3/8" OD-5/8" OD
KMS-750/1122/1230/ 1400/1401MLH KMS-1401MLJ	R404-20810 R404-35810 R404-55810	1/2" OD-5/8" OD
KMS-822/830MLH *Soldered connections	HS-0251 25' HS-0251 35' HS-0252 55'	1/2" OD-5/8" OD
KMS-2000MLH *Soldered connections	HS-0243 25' HS-0244 35' HS-0245 55'	1/2" OD-3/4" OD
Note: If hard piping or fabricating a line set, insulate both lines separately and use Quick Connect Kit HS-2150 except on solder connection models.		

## Remote Condenser Installation on Roof

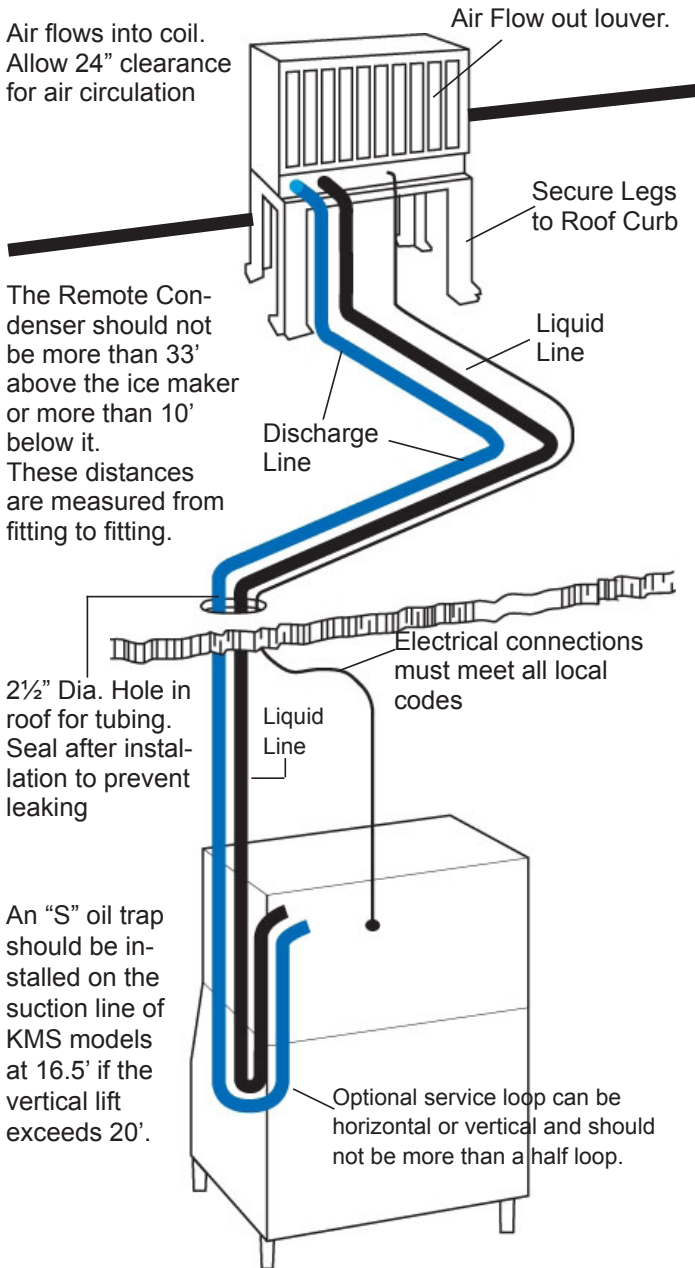

## Line Set Installation:

Universal line set adapter kits (part number HS-2150 for KM and HS-0231 for certain KMS) are available if you need to field fabricate your line set. Both lines should be insulated separately the entire length of run.

The refrigerant charge for a new unit is distributed between the unit head and the URC condenser. The line set has a minimal holding charge of 15 to 30 psig refrigerant vapor.

If you need to field fabricate your line set, or shorten/ lengthen a precharged line set, you can do so by following these steps:

1. Using the correct connector kit, braze the line set connection. (If you shorten or lengthen a pre-charged line set, recover the holding charge, cut/lengthen, and braze the connections.)
2. Pressurize the lines and leak check all braze joints.
3. Evacuate the lines through the service ports on the quick connect fittings.
4. Charge both lines with 15 to 30 psig R-404A vapor.

To make quick connect connections:

1. Lubricate threads and O-rings with clean refrigerant oil.

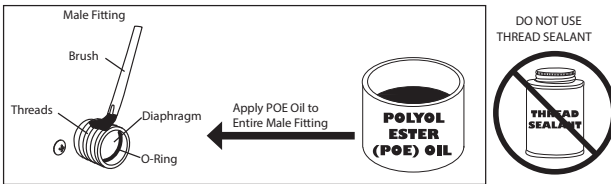

2. Align the male and female couplings straight.
3. Tighten the female connector until it bottoms out.  
**Note:** Always use a back up wrench when tightening these fittings.
4. Once secure, mark a reference line and turn the fittings an additional 1/6 turn to assure a good brass seal.



5. Leak check the joints with soap bubbles or electronic leak detector.

## **Connectors:**

If a remote unit needs to be moved or disconnected for service, it is important to understand the following connector information. The fittings used on pre-charged line sets are one shot couplings. They do not re-seal when disconnected. Always evacuate the system before disconnecting the fittings and replace them with new sealed fittings.

## **Moving a Remote:**

In the event that a remote unit must be moved, the connectors can be replaced or you can use this simple method to save time and effort.

If the existing connectors are leak free:

1. Evacuate and recover the refrigerant.
2. Cut the line set about 6" away from the connectors at the condenser and head and pinch the ends to seal the system.
3. Move the unit to the new location and route new lines between the head and condenser that are properly sized.
4. Cut the pinched ends off the condenser and head and resolder the lines together.
5. Leak check, re-insulate lines.
6. Evacuate and recharge the unit to nameplate rating.

This the quickest method and eliminates the need for new connectors.

## **Excess Line Set:**

Leaving excess line set coiled on the rooftop or in the ceiling is not recommended. It can cause oil traps or be easily crimped and restricted. For installations with excessive line set length, Hoshizaki recommends that you follow these steps to cut out the excess line set before making the connections.

1. Recover the line set holding charge through the access schrader valves on the connectors.
2. Cut out the excess line.
3. Resolder the lines.
4. Leak check, evacuate and charge with 15 to 30 PSI vapor charge using the correct refrigerant.
6. Re-insulate the connection areas.
5. Make the connections to the condenser and head following the standard connection process.

# R-404A Refrigerant System Information

## System Charge:

The ice machine head and URC condenser are shipped with enough refrigerant charge for up to 66 ft. of line set length. The maximum line set length is 100 equivalent feet from the head to the condenser for most remote models. The maximum for KMS models is 66 equivalent feet.

For applications longer than 66 ft. (up to the maximum 100 ft. length), additional refrigerant must be added.

For any length over 66 ft. add 0.4 oz. per foot.

For units utilizing 3/8" L.L. no line size change is needed.

For units utilizing 1/4" L.L. and 3/8" D.L., the line size should be increased to 3/8" L.L. and 1/2" D.L. for the entire length of the run then add 16.5 oz + 0.4 oz. per foot over 66 foot.

### Note:

- (1) Recommended line sizes are the same as listed in the line set application chart.
- (2) Older models utilize R-502 refrigerant or R-22 refrigerant. Always check the unit nameplate for the correct refrigerant type.

**\*DO NOT mix refrigerants!**

**\*DO NOT connect components using different type refrigerants!**

- (3) If refrigerant is added due to extended line set length, mark the correct total charge on the unit nameplate for future reference.
- (4) When routing and installing remote lines, always use standard refrigerant piping practices.
- (5) Hoshizaki recommends eliminating any excess loops in a pre-charged line set application as noted before making the unit connections. This will eliminate oil traps and possible crimps in the excess tubing.
- (6) A service loop can be included behind the unit as shown in the installation illustration to allow the unit to be moved away from the wall if needed.

## Critical Charge Amount:

The total system charge is critical for proper operation according to Hoshizaki specification. Always weigh in the proper charge per the following charge chart. (Remote units show standard charge good for up to 66 ft.) Unit charge information is also found on the unit nameplate.

## Cuber Charge Chart R-404A

Model	Total Charge	Refrigerant
<p>Note that MRH/SRH/MLH models include condenser charge. To convert to grams, multiply oz x 28.35.                      *Always verify total charge with nameplate amount. If listed charge is different, use nameplate amount.</p>		
AM-50BAE	4.2 oz	R134A
KM-61BAH	6.4 oz	R134A
KM-101BAH	7.8 oz	R134A
KM-151BAH	8.5 oz	R134A
KM-151BWH	10.7 oz	R134A
KM-201BAH	12 oz	R404A
KM-201BWH	11 oz	R404A
KM-251BAH	15 oz	R404A
KM-255BAH	1 lb 1 oz	R404A
KM-260BAH	12.7 oz	R404A
KM-260BWH	13.8 oz	R404A
KM-280MAH(-E)	12 oz	R404A
KM-320MAH(-E)	1 lb 4.3 oz	R404A
KM-320MWH	1 lb 0.8 oz	R404A
KM-461MAH	1 lb 11.5 oz	R404A
KM-461MRH	5 lbs 4.7 oz	R404A
KM-461MWH	1 lb 2.5 oz	R404A
KM-500MAH(-E)	1 lb 10 oz	R404A
KM-501MRH	4 lbs	R404A
KM-501/515MWH	15 oz	R404A
KM-501MAH	1 lb 10 oz	R404A
KM-515MAH	1 lb 7.3 oz	R404A
KM-515MAH-E	1 lbs 2.5 oz	R404A
KM-515MRH	4 lbs 4.8 oz	R404A
KM-600MAH	1 lbs 11 oz	R404A
KM-630MAH(-E)	1 lb 6 oz	R404A
KM-630MRH	4 lbs 4 oz	R404A
KM-630MWH	1 lb 4.3 oz	R404A

## Cuber Charge Chart (continued)

<b>Model</b>	<b>Total Charge</b>	<b>Refrigerant</b>
KM-630MWH LO>M1	1 lb 3 oz	R404A
KM-630MWH-M2	1 lb 4.3 oz	R404A
KM-650MAH(-E)	1 lb 6.6 oz	R404A
KM-650MRH	5 lbs 11 oz	R404A
KM-650MWH	1 lb 5.7 oz	R404A
KM-900MAH(-50)	3 lbs 7 oz	R404A
KM-900MRH(3)	9 lbs 14 oz	R404A
KM-900MWH(3)	1 lb 14 oz	R404A
KM-900MWH-L0-M2	1 lb 7 oz	R404A
KM-901MAH	2 lbs 15 oz	R404A
KM-901MRH(3)	9 lbs 4 oz	R404A
KM-901MWH	1 lb 15.4 oz	R404A
KM-1300MAH	4 lbs	R404A
KM-1300MRH	9 lbs 15 oz	R404A
KM-1300MWH	2 lbs 9 oz	R404A
KM-1300SAH(3)(-E)	3 lbs 14 oz	R404A
KM-1300SRH(3)	11 lbs 7 oz	R404A
KM-1300SWH(3)	2 lbs 2 oz	R404A
KM-1301SAH	3 lbs 15.5 oz	R404A
KM-1301SAH-E	3 lbs 9.1 oz	R404A
KM-1301SRH(3)	10 lbs 5.8 oz	R404A
KM-1301SWH(3)	2 lbs 8.2 oz	R404A
KM-1340MAH	4 lbs 11.4 oz	R404A
KM-1340MRH	9 lbs 14.7 oz	R404A
KM-1340MWH	2 lbs 9 oz	R404A
KM-1400SWH-M/3M	2 lbs 2.4 oz	R404A
KM-1600SWH(3)	3 lbs 1 oz	R404A
KM-1600M/SRH(3)	14 lbs 12 oz	R404A
KM-1601MRH(3)	24 lbs 4.0 oz	R404A
KM-1601SAH (3)	3 lbs 12.5 oz	R404A



### Cuber Charge Chart (continued)

<b>Model</b>	<b>Total Charge</b>	<b>Refrigerant</b>
KM-1601SRH(3)	24 lbs 14.6 oz	R404A
KM-1601SWH(3)	3 lbs 1 oz	R404A
KM-1800SAH(3)	4 lbs 7 oz	R404A
KM-1800SRH(3)	15 lbs 7 oz	R404A
KM-1800SWH(3)	3 lbs 2 oz	R404A
KM-1900SAH(3)	4 lbs 10.1 oz	R404A
KM-1900SRH(3)	23 lbs 7.7 oz	R404A
KM-1900SWH(3)	3 lbs 1.4 oz	R404A
KM-2000SRH3	16 lbs 2 oz	R404A
KM-2000SWH3	3 lbs 7 oz	R404A
KM-2100SWH(3)	3 lbs	R404A
KM-2100SRH(3)	16 lbs 2 oz	R404A
KM-2400SRH3	24 lbs	R404A
KM-2500SWH(3) < C1	4 lbs 11.5 oz	R404A
KM-2500SWH3 D0 >	3 lbs 7.6 oz	R404A
KM-2500SRH3	24 lbs 12.3 oz	R404A
KMD-450MAH	1 lb 5.2 oz	R404A
KMD-450MWH	1 lb 0.9 oz	R404A
KMD-460MAH	1 lb 5.2 oz	R404A
KMD-530MAH	1 lb 2.5 oz	R404A
KMD-700MAH	2 lbs 8.6 oz	R404A
KMD-700MRH	10 lbs 0.5 oz	R404A
KMD-700MWH	1 lb 10 oz	R404A
KMD-850MAH	2 lbs 8.2 oz	R404A
KMD-850MRH	9 lbs 4.2 oz	R404A
KMD-850MWH	1 lb 12.6 oz	R404A
KMD-900MAH	3 lbs 8.3 oz	R404A
KMD-900MRH	9 lbs 6 oz	R404A
KMD-900MWH	2 lbs	R404A

### Cuber Charge Chart (continued)

<b>Model</b>	<b>Total Charge</b>	<b>Refrigerant</b>
KMD-901MAH	4 lbs 3 oz	R404A
KMD-901MRH	9 lbs 14.7 oz	R404A
KMD-901MWH	2 lbs 3.3 oz	R404A
KMH-2000SWH(3)	3 lbs 1.4 oz	R404A
KMH-2000SRH(3)	16 lbs 1.5 oz	R404A
KML-250/350MAH	1 lb 2 oz	R404A
KML-250MWH	14.1 oz	R404A
KML-350MWH(-M3)	13.5 oz	R404A
KML-351MAH/MWH	1 lb 2 oz	R404A
KML-450MAH	1 lb 6 oz	R404A
KML-450MWH	15.8 oz	R404A
KML-451MAH T0 & T2	1 lb 13.1 oz	R404A
KML-451MAH T1, U1>	1 lb 8.7 oz	R404A
KML-451MWH < U0	1 lb 2.3 oz	R404A
KML-451MWH U1>	15.2 oz	R404A
KML-600MAH	2 lbs 4 oz	R404A
KML-600MRH	10 lbs 6 oz	R404A
KML-631MAH	2 lbs 10.3 oz	R404A
KML-631MRH	9 lbs 8.4 oz	R404A
KML-631MWH	1 lb 9.6 oz	R404A
KMS-750MLH	10 lbs 11 oz	R404A
KMS-822MLH	14 lb 15.9 oz	R404A
KMS-830MLH	13 lbs 10.5 oz	R404A
KMS-1122MLH	16 lbs 5 oz	R404A
KMS-1230MLH	16 lbs 5 oz	R404A
KMS-1400MLH	16 lbs 5 oz	R404A
KMS-1401MLH/MLJ	16 lbs 5 oz	R404A
KMS-2000MLH	27 lbs 5.4 oz	R404A

\*Always verify total charge with nameplate amount. If listed charge is different, use nameplate amount.

<b>URC Charge Chart</b> (Condenser charge is included in total charge.)		
<b>Model</b>	<b>Factory Charge</b>	<b>Refrigerant</b>
URC-5F/6F	1lb 14oz	R404A
URC-7F	2lbs 5oz	R404A
URC-9F	3lbs 14.8oz	R404A
URC-12F	4lbs 7oz	R404A
URC-14F	4lbs 7oz	R404A
URC-20F	7lbs 11oz	R404A
URC-21F	9lbs 11oz	R404A
URC-22F	7lbs 11.5oz	R404A
URC-23F	9lbs 11oz	R404A
URC-24F	11lbs	R404A
SRC-10H	8lbs 6oz	R404A
SRC-14H	10lbs 12oz	R404A
SRK-7H	10lbs 4oz	R404A
SRK-8H	14lbs 14oz	R404A
SRK-10H	14lbs 8.8oz	R404A
SRK-13H	15lbs 14oz	R404A
SRK-14H	15lbs 14oz	R404A
SRK14J	15lbs 14oz	R404A
SRK-20H	26lbs 14.3oz	R404A

### **Refrigerant Oil:**

All R-404A models use Polyol Ester (POE-EAL) oil. POE oil absorbs moisture easily. Extra care must be taken to reduce the possibility of moisture entering the system during service. If moisture contamination is suspected, the oil should be changed and the liquid line drier must be replaced. Changing the oil requires removal of the compressor so that the oil can be drained and replaced with the correct amount. See compressor data chart for oil amount. Replacement compressors are shipped with POE oil.

## Heat Load for AC & Cooling Tower

The heat of rejection information listed below by model number should be used for sizing air conditioning equipment or water-cooled cooling tower applications.

<b>Cuber Heat Load Chart BTU/hr.</b>		
<b>Model</b>	<b>Air Cooled</b>	<b>Water Cooled</b>
AM-50BAH	1,850	----
KM-61BAH	1,600	----
KM-101BAH	2,320	----
KM-151BAH	3,840	3,840
KM-201BAH	4,120	4,120
KM-251BAH	5,300	5,300
KM-255BAH	4,100	4,100
KM-260BAH	4,313	4.313
KM-280MAH(-E)	8,159	----
KM-320M_H	6700	5,800
KM-320M_H(-E)	5400	----
KM-461M_H	7,800	7,300
KM-500MAH-E	7,371	----
KM-501M_H	9,200	6,800
KM-515M_H	9,600	8,300
KM-515MAH-E	10,400	----
KM-600MAH	9,500	----
KM-630M_H	9,639	8,770
KM-630MAH-E	10,375	----
KM-650MAH	10,600	10,000
KM-650M_H-E	9,800	10,000
KM-900M_H	14,800	13,000
KM-900MAH-50	14,375	----
KM-900M_H	14,800	13,000
KM-900MAH-50	14,375	----
KM-901M_H	15,400	13,500

## Cuber Heat Load Chart BTU/hr. (continued)

Model	Air Cooled	Water Cooled
KM-901M_H	15,400	13,500
KM-1300M_H	19,800	15,185
KM-1300S_H	19,800	15,560
KM-1300S_H3	18,130	15,450
KM-1300SAH-E	20,400	----
KM-1301S_H(3)	20,300	17,600
KM-1301SAH-E	19,000	----
KM-1340M_H	22,600	20,500
KM-1400SWH-M	----	22,800
KM-1600S_H	----	18,220
KM-1600S_H3	----	17,560
KM-1601S_H	----	23,100
KM-1601S_H3	----	23,500
KM-1800S_H	24,720	26,200
KM-1800S_H3	24,150	25,900
KM-1900S_H	23,800	26,800
KM-1900S_H3	23,700	27,100
KM-2000S_H3	----	27,170
KM-2100SWH3	----	31,100
KM-2500SWH3	----	35,500
KM-410M_H	6,000	6,300
KMD-450M_H	7,700	6,800
KMD-460M_H	7,700	----
KMD-530M_H		----
KMD-700M_H	14,590	12,200
KMD-850M_H	13,200	10,400
KMD-900M_H	18,865	13,480
KMD-901M_H	16,300	12,400
KMH-2000SWH	----	22,170

<b>Cuber Heat Load Chart BTU/hr. (continued)</b>		
<b>Model</b>	<b>Air Cooled</b>	<b>Water Cooled</b>
KML-250M_H	5,560	5,000
KML-350M_H	6,550	5,600
KML-350MWH L0~M2	----	5,370
KML-351M_H	6,550	5,500
KML-450M_H	7,480	6,180
KML-451M_H	7,100	6,400
KML-600M_H	11,580	9,850
KML-631M_H	11,600	9,900

<b>Condenser Heat Load Chart BTU/hr.</b>	
<b>Model</b>	<b>BTU/hr.</b>
URC-5F	*9,600
URC-9F	*14,000
URC-14F	*20,800
URC-22F	*30,400
URC-23F	40,600
KMS-822MLH & SRK-10H	16,200
KMS-830MLH & SRK-10H	16,900
KMS-1122MLH & SRK-12H	21,300
KMS-1230MLH & SRK-13H	23,700
KMS-1400MLH & SRK-14H	25,270
KMS-1401MLH & SRK-14H	27,900
KMS-1401MLJ & SRK-14J	28,800
KMS-2000MLH & SRK-20H	37,300

\* Max BTU/hr for largest unit...see performance data by model application. Figures shown are at 90° F air temp. 70° F water temp. conditions.

\*\*Always allow for a pressure differential of 10 psi across the water cooled condenser. This means that the inlet pressure must be at least 10 psi higher than the outlet pressure to allow for proper water flow through the water regulating valve and condenser.

## Component Technical Data

### “E” Control Board Adjustment Guide

The early “E” boards have 8 dip switches. The latest “E” boards have 10 dip switches.

“E” Board Dip Switch Setting Guide					
ADJUSTMENTS	DIP #	Switch Code 1=ON 0=OFF			
DEFROST	1	0	1	0	1
COMPLETION	2	0	0	1	1
TIMER	seconds	60	90	120	180
PUMP OUT	3	0	1	0	1
TIME	4	0	0	1	1
Length of pump out	seconds	10	10	10	20
Min Defrost Time	seconds	150	180	120	180
Inlet Water Valve	status	OFF	OFF	ON	OFF
PERIODIC	5	0	1	0	1
PUMP OUT	6	0	0	1	1
FREQUENCY	cycles	1/1	1/2	1/5	1/10
BIN CONTROL	7	OFF for thermostatic control ON for mechanical control			
TEST	8	ALWAYS OFF			
MAX. FREEZE					Default
TIME	9	1	1	0	0
(Improved E board only.)	10	1	0	1	0
	minutes	75/50hz 60/60hz	70	50	60

**NOTE:**

1. **TO IMPROVE BUILT-IN CLEANING** Adjust switches 1&2 to provide for longer flush and switches 5&6 to every cycle pump-out 1/1. Do not adjust 1&2 on KM150/250 in high ambient area.
2. **DO NOT ADJUST 3, 4, 7, 8, 9 & 10** from factory setting!
3. **DO NOT MAKE CONNECTION to the red K-4 terminal** unless a special bin control / red connector is provided. Dip switch 7 must be ON in this case.
4. Dip-switches 9 & 10 are on improved “E” board only.

### “E” Board S4 Switch Setting Chart

The chart below reflects the factory dip-switch settings for R-404A models using the “E” board.

\* Adjustments may be made to switches 1, 2, 5 & 6 to improve the built-in cleaning ability as per the DIP SWITCH SETTING GUIDE.

\* If you replace a control board, match the cleaning settings with the original board. Switches 3, 4, 7, 8, 9 & 10 must remain in the factory position.

\* Settings are for thermostatic bin control models.

For units with mechanical bin control S7 is “ON”.

\* Models listed as -E or H3 are individual units.

Models listed (3) includes single and 3 phase units.

Factory Dip Switch Settings:	SWITCH CODE 1=ON 0=OFF									
Model / Serial code	1	2	3	4	5	6	7	8	9	10
KM-280MAH	1	0	0	1	1	1	0	0	0	0
KM-280MWH	0	0	0	1	1	1	0	0	0	1
KM-320MA/W	0	0	0	1	1	1	0	0	0	0
KM-320MAH-E	1	0	0	1	1	1	0	0	1	1
KM-461MAH	0	0	0	0	1	1	0	0	1	0
KM-461MRH	1	0	0	0	1	1	0	0	1	0
KM-461MWH KM-501MAH	0	1	0	0	1	1	0	0	1	0
KM-501MW/R KM-600/650MAH	0	0	0	0	1	1	0	0	0	0
KM-500MAH-E KM-515MAH-E KM-515M_H KM-1900SAH(3) KM-1900SWH(3)	0	0	0	0	0	0	0	0	1	0
KM-630MA/R	0	0	0	0	1	1	0	0	1	0
KM-630MWH	0	0	0	0	1	1	0	0	0	0
KM-650MAH-E	0	0	0	0	0	0	0	0	1	1
KM-650MRH	0	0	0	0	1	1	0	0	1	0
KM-650MA/W	0	0	0	0	1	1	0	0	0	0



E Board Continued:	SWITCH CODE 1=ON 0=OFF									
	1	2	3	4	5	6	7	8	9	10
Model										
KM-900MAH-50	0	0	1	0	1	1	0	0	1	0
KM-901M_H(3)	1	0	1	0	1	1	0	0	0	1
KM-900M_H(3) KM-1300MWH KM-1340MWH KM-1600MRH(3) KM-1601MRH(3)	0	0	1	0	1	1	0	0	0	1
KM-1300MAH KM-1300S_H(3) KM-1340MAH KM-1800SA/WH(3) KM-2000SW/RH3	0	0	1	1	1	1	0	0	1	0
KM-1300SAH-E	0	0	1	1	0	0	0	0	1	0
KM-1300MRH KM-1340MRH	0	0	1	0	1	1	0	0	0	0
KM-1600SRH(3)	1	0	1	1	1	1	0	0	0	0
KM-1600SWH(3)	0	0	0	0	0	0	0	0	0	1
KM-1601SWH(3)	0	0	0	0	1	1	0	0	0	1
KM-1601SRH(3)	1	0	1	0	0	0	0	0	0	0
KM-1601SRH350	1	0	0	0	1	1	0	0	0	0
KM-1800SRH(3)	0	1	1	1	1	1	0	0	1	0
KM-1900SRH(3) KM-2100SRH(3) KM-2100SWH350 KM-2100SRH350	1	0	1	1	0	0	0	0	1	0
KM-1900SAH350 KM-2100SWH3	0	0	0	0	0	0	0	0	1	0
KM-2400SRH3	0	0	1	0	0	0	0	0	0	1
KM-2500SW/RH3	0	0	0	0	0	0	0	0	0	1
KMD-410MAH	0	0	0	0	1	1	1	1	0	0
KMD-410MWH	0	0	0	0	1	1	1	1	1	0
KMD-450MA/WH	0	0	1	1	1	1	1	1	0	1
KMD-460MA/WH KMD-530MA/W/R	0	0	0	0	1	1	1	0	0	0

E Board Continued:	SWITCH CODE 1=ON 0=OFF									
Model / Serial code	1	2	3	4	5	6	7	8	9	10
KMD-700MAH KMD-900MA/RH	0	0	0	0	1	1	1	0	0	0
KMD-700MW/RH KMD-900MWH	1	0	0	0	1	1	1	0	0	0
KMH-2000SWH(3) KMH-2000MRH(3)	0	0	0	0	0	0	0	0	1	1
KML-*250MAH KML-351MAH T0>	0	0	0	1	1	1	0	0	1	0
KML-*250MWH KML-*350MA/WH KML-351MAH >S0	0	0	0	1	1	1	0	0	0	1
KML-351MWH	1	0	1	1	0	0	0	0	0	1
KML-*450MA/WH KML-*600MA/WH	0	0	0	0	1	1	0	0	0	1
KML-451MAH	0	0	0	0	0	0	0	0	0	1
KML-451MWH	1	0	0	0	1	1	0	0	0	1
KML-*600MRH	1	0	0	0	1	1	0	0	0	1
KML-631MAH S0,S2	1	1	0	0	1	1	0	0	0	1
KML-631M_H >S2	1	0	0	0	1	1	0	0	0	1

**Remember the following when handling electronic control boards:**

\* You should avoid static shock to the board. Always touch the frame of the unit prior to removing a replacement board from the anti -static plastic bag or handling the board.

\* Make adjustments to the control board with the power off using a small blade screwdriver or other sharp point. Once adjustment is made, turn power back on to initialize the change.

\*Factory settings are for maximum efficiency and proper operation. Adjustments to 1, 2, 5, & 6 will use additional water to flush and improve the built-in cleaning.

## “G” Board S4 “H” Board S1 Dip Switch Adjustment Guide

**NOTE:**

1. G board part number is 2A3792-01
2. Dip switches have different functions from E board.
3. Do not adjust dip switches 3, 4, 7, & 8 from factory setting.
4. Do not adjust 5 & 6 on KM251/255B since they have multiple fill cycles.
5. If G Board is used without a mechanical bin control, a jumper must be installed on the red K4 connector.

**Additional Dip Switches**

“G” Board S5 & “H” Board S2 Dip switches are factory set and SHOULD NOT be adjusted!

ADJUSTMENTS	DIP #	SWITCH CODE: 1=ON 0=OFF				
DEFROST	1	0	1	0	1	
COMPLETION	2	0	0	1	1	
TIMER	seconds	60	90	120	180	
PUMP OUT TIME	3	0	1	0	1	
	4	0	0	1	1	
	Length of pump out	seconds	10	10	10	20
	Min defrost time	seconds	150	180	120	180
	Inlet water valve	status	OFF	OFF	ON	OFF
PERIODIC PUMP OUT FREQUENCY	5	0	1	0	1	
	6	0	0	1	1	
	cycles	1/1	1/2	1/5	1/10	
PUMP @ end of defrost	7	ON - YES		OFF - NO		
TEST	8	ALWAYS OFF				
MAX FREEZE TIME	9	1	1	0	DEFAULT	
	10	1	0	1	0	
	minutes	75/50hz 60/60hz	70	50	60	

<b>“G” Board Factory Dip Switch Settings</b>										
<b>S4 Block</b>	<b>SWITCH CODE 1=ON 0=OFF</b>									
<b>Model</b>	<b>1</b>	<b>2</b>	<b>3</b>	<b>4</b>	<b>5</b>	<b>6</b>	<b>7</b>	<b>8</b>	<b>9</b>	<b>10</b>
KM-251BAH	0	1	0	1	1	1	1	0	0	0
KM-255BAH	0	1	0	1	1	1	1	0	0	0
*KM-320M	1	0	0	1	1	1	0	0	0	0
*KM-320MAH-E	1	0	0	1	1	1	0	0	1	1
*KM-515MAH	0	0	0	0	1	1	1	0	1	0
*KM-515MAH-E *KM-515MW/RH	0	0	0	0	0	0	0	0	1	0
*KM-600MAH	0	0	0	0	1	1	0	0	0	0
*KM-650MAH	1	0	0	0	1	1	1	0	0	0
*KM-650MW/RH	1	0	0	0	1	1	0	0	0	0
*KM-650MAH-E	1	0	0	1	1	1	0	0	1	1
*KM-901MAH	0	0	1	0	1	1	1	0	0	1
*KM-901MW/RH *KM-901MRH3 *KM-901MAH-E	1	0	1	0	1	1	0	0	0	1
*KM-1301SAH(3) *KM-1301SWH(3) *KM-1601SAH(3)	0	0	1	1	1	1	1	0	0	0
*KM-1301SRH(3)	0	0	1	1	1	1	1	0	1	0
*KM-1301SAH-E	0	0	1	1	1	1	1	0	1	1
KM-1340MAH	0	0	1	1	1	1	0	0	0	0
KM-1340MWH	0	0	1	0	1	1	0	0	0	1
KM-1340MRH	0	0	1	0	1	1	0	0	0	0
*KM-1400SWH-M *KM-1400SWH-M3	0	0	0	0	0	0	1	0	0	0
*KM-1601SWH *KM1601SRH(3)	1	0	0	0	1	1	0	0	0	0
*KM-1601SWH3	0	0	0	0	1	1	0	0	0	0
*KM-1900SAH(3) *KM-2500SW/RH3	0	0	0	0	0	0	0	0	0	1

<b>“G” Board Factory Dip Switch Settings</b>										
<b>S4 Block</b>	<b>SWITCH CODE 1=ON 0=OFF</b>									
*KM-1900SWH(3) *KM-1900SAH350 *KM-2100SWH(3)	0	0	0	0	0	0	0	0	1	0
*KM-1900SRH(3) *KM-2100SRH(3) *KM-2100SWH350 *KM-2100SRH350	1	0	1	1	0	0	0	0	1	0
*KML-351MAH	0	0	0	0	0	0	1	0	0	1
*KML-351MWH	1	0	1	1	0	0	0	0	0	1
*KML-451MAH	0	0	0	0	0	0	0	0	0	1
*KML-451MWH	1	0	0	0	1	1	0	0	0	1
*KML-631M_H	0	0	0	0	1	1	1	0	0	1
*KMD-460MA/WH *KMD-530M_H	0	0	0	0	1	1	1	0	0	0
*KMD-850M_H, *KMD-901M_H *KMS-830MLH(3) *KMS-1122MLH(3) KMS-1401MLJ(3)	0	0	0	1	1	1	1	0	0	0
KMS-750MLH, KMS-822MLH(3) KMS-1400MLH	0	0	0	1	1	1	1	0	0	1
KMS-1230MLH	1	0	0	1	1	1	1	0	0	1
KMS-1401MLH(3)	0	0	0	1	0	0	1	0	0	1
KMS-2000MLH(3)	0	0	0	0	1	1	1	1	0	0
<b>S5 Block</b>	<b>IMPORTANT, DO NOT ADJUST!</b>									
<b>Model:</b>	<b>1</b>	<b>2</b>	<b>3</b>	<b>4</b>	<b>5</b>					
All models with *	0	0	0	0	0					
KM-251BAH KMS-1401MLJ	1	1	0	0	1					
KM-255BAH	1	0	1	0	1					
KMS-1230/1400/ 1401MLH	0	1	0	0	0					

## Positive Harvest Feature:

The small KM's, KMS and KM-1301S\_H(3) models include the positive harvest feature. This feature turns off the water valve and turns on the pump motor for the last 0~50 seconds of harvest.

The G Board and additional relays are used to allow the pump to turn in the correct direction during this feature.

A full explanation of the sequence of operation, including these relays, is included in the individual service manual.

The H Board used on small KM's has the same feature however relays are included on the board.

<b>“H” Board Factory Dip Switch Settings</b>										
<b>NOTE:</b> DO NOT adjust S1 - 3, 4, 7, 8, 9, 10 or S2 from the factory setting!										
S1 SWITCHES	SWITCH CODE 1=ON 0=OFF									
Model:	1	2	3	4	5	6	7	8	9	10
*KM-61/151BAH	0	0	1	1	1	1	0	1	0	1
KM-101BAH	1	0	1	1	1	1	0	1	1	0
KM-151BWH	0	0	1	1	1	1	0	1	1	0
KM-201BAH	0	0	0	0	1	1	0	1	0	1
KM-201BWH	0	0	0	0	1	1	0	1	1	0
KM-260BAH	0	0	0	0	1	1	1	0	0	1
KM-260BWH	0	0	0	0	1	1	1	0	1	0
KMD-410MAH KMS-2000MLH(3)	0	0	0	0	1	1	1	1	0	0
KMD-410MWH	0	0	0	0	1	1	1	1	1	0
KMD-450MA/WH	0	0	1	1	1	1	1	1	0	0
S2 SWITCHES	DO NOT ADJUST!									
Model:	1	2	3	4	5	6				
Models with *	0	0	0	0	0	0				
KM-201/260B	1	0	0	0	0	0				
KM-450MA/WH	1	0	0	0	0	1				
KMD-410M_H	1	1	1	0	0	0				
KMS-2000MLH(3)	1	1	0	0	0	0				

## **“E” Control Board Functions:**

An instruction label explaining the “E” board features is included on the unit. It can be found either on the control box cover, inside of the front panel, or under the top panel. A stick-on label is included with the service replacement board. If you are replacing an “E” board, be sure to place the new label over the original label. This will advise anyone performing future service that the original board has been replaced and explain the application switch as outlined below.

The #2A1410-02 replacement board has an application switch between relays X3 & X4 that is not included on the original factory board supplied with the unit. This application switch allows the replacement board to be used on older C and Alpine control board models. The application switch has 2 positions : C & ALP. On R-404A models, this switch must be in the ALP position. If the switch is left in the C position, the compressor contactor will energize as soon as power is supplied to the unit whether the power switch is ON or OFF.

There are 4 green LED's which light in sequence throughout the unit operation.

NOTE: The green LED's are not numbered consecutively. LED1 is located at the edge of the board beside the K-2 transformer connection. The numbering sequence from the outside edge of the board is 1, 4, 3, and 2.

The green LED's are also used for a built-in output test that can be conducted to diagnose a bad board. The label explains the output test procedure. Always assure that dip # 8 is in the OFF position before doing the output test!

The correct lighting sequence for the output test is as follows: When control switch is ON and output test switch S-3 is ON or pressed, after a 5 second delay, LED2 lights up. 5 seconds later LED2 goes out and LED3 lights up. 5 seconds later LED3 goes out and LED4 lights up. 5 seconds later LED4 goes out and LED1 lights up. 5 seconds later LED1 goes out and LED4 lights up to begin the normal sequence of operation.

If the LED's follow this sequence, the board sequence is OK. If any other lighting sequence occurs, the board is bad.

A copy of the “E” board label is included in this handbook. Review the board label thoroughly to understand the “E” board functions.

## Manual Reset Safeties:

The “E” control board can have up to 5 manual reset safeties. They are outlined in the control board function label. These safeties shut the unit down and assist the service technician in diagnosing the problem.

The safeties include the following audible and visual alarms:

1 Beep = 127°F (52.8°C) high evaporator temperature safety.

2 Beeps & orange LED = 2 consecutive 20 minute harvest cycles.

3 Beeps & yellow LED = 2 consecutive maximum freeze cycles.

With Dip Switch #7 ON:(Mechanical Bin control installed)

4 Beeps = Short circuit on mechanical bin control circuit.

5 Beeps = Open circuit on mechanical bin control circuit.

**\*To reset either safety: Press the white reset button on the control board with the power ON.**

Next, proceed to check the items outlined on the function label. The items listed on the function label represent the most common reasons that will trigger the safety.

## Voltage Protection:

Built-in voltage protection for the “E” board will automatically shut the unit down and beep to signify that a high or low voltage problem has occurred:

6 Beeps = Low voltage condition.

7 Beeps = High voltage condition.

A voltage alarm will **automatically reset** when voltage is corrected.

If a voltage alarm occurs, check the power supply circuit to assure an independent circuit is used and that all external connections are secure. If voltage alarm continues, contact an electrician or the power company.

**The high and low voltage protections are the only board alarms that automatically restart the unit.** This occurs when the voltage returns to normal.

If constant voltage fluctuation occurs, additional external voltage protection will be required.



## “E” Board Control Board Lights, Alarms and Test

At startup, a 5 second delay occurs while the control board conducts an internal timer check. A beep occurs when power is turned off. The red LED indicates proper control voltage and remains on unless a control voltage problem occurs. The green LEDs, 1 through 4 energize and sequence from initial startup as listed in the table below. Note that the order of LEDs from the outer edge of the board is 1, 4, 3, 2.

Sequence Step	LED	Energized Components	Time LEDs are on		
			Min.	Max.	Avg.
1-Minute Fill Cycle	4	WV			1 minute
Harvest Cycle	1, 4, 2	Comp, FMR, WV,HGV	2 minutes	20 minutes	
Freeze Cycle	1	Comp, FM/ FMR, PM, LLV	5 minutes	Freeze timer setting	30 to 35 minutes
Pump-out Cycle	1, 4, 3, 2	Comp, FMR, WV*, PM, HGV, SR, DV	10 Seconds	20 Seconds	*pump-out timer setting

The built-in safeties shut down the unit and have alarms as listed below.

No. of Beeps (every 3 sec.)	Type of Alarm	Notes
1	High Evaporator Temp. (Temperature > 127°F / 53°C)	Check for harvest problem (stuck HGV or relay), hot water entering unit, Stuck HM or shorted thermistor.
2	Harvest Backup Timer (harvest > 20 min. for two cycles in a row)	Orange “H TIMER” LED on. Check for open thermistor, HGV not opening, TXV or LLV leaking by, low charge, inefficient Comp, pr WRV leaking by.
3	Freeze Timer (freeze > freeze timer setting for two cycles in a row)	Yellow “ F TIMER” LED on. Check for F/S stuck closed (up), WV leaking by, HGV leaking by, PM not pumping, TXV not feeding properly, LLV not opening, low charge, HM not bypassing or inefficient Comp.
4	Short Circuit (mechanical Bin control models)	Short circuit between the K4 connection on the control board and the bin control. Check connections and replace wire harness is necessary.
5	Open Circuit (mechanical Bin control models)	Open circuit between the K4 connection on the control board and the bin control. Check connections and replace wire harness if necessary.
To reset the above safeties, press the “Alarm Reset” button with the power supply ON.		
6	Low Voltage (92Vac+/- 5% or less)	Red LED turns off if voltage protection operates. The control voltage safeties automatically reset when voltage is corrected.
7	High Voltage (147 Vac +/- 5% or more)	

Legend: **Comp**-compressor; **DV**-drain valve (KMD,KML only); **FM**-Fan motor; **FMR**-fan motor remote; **F/S**-float switch; **HGV**\_hot gas valve; **HM**-headmaster (C.P.R); **LLV**-liquid line valve; **PM**-pump motor; **SR**-service relay (KMD,KML only); **TXV**-thermostatic expansion valve; **WRV**-water regulating valve; **WV**-water valve.

To perform an output test, first move the control switch to the “ICE” position. Press the “OUTPUT TEST” button. The correct LED lighting sequence is none, 2, 3, 4, 1. Components (e.g., compressor) cycle during the test. Following the test, the ice maker resumes operation. The Dip Switches should be adjusted per the chart in the unit’s service manual. S4 dip switch 8 must remain off.

## “G” Board Control Board Lights, Alarms and Test

At startup, a 5 second delay occurs while the control board conducts an internal timer check. A beep occurs when power is turned off. The red LED indicates proper control voltage and remains on unless a control voltage problem occurs. The green LEDs, 1 through 4 energize and sequence from initial startup as listed in the table below. Note that the order of LEDs from the outer edge of the board is 1, 4, 3, 2.

Sequence Step	LED	Energized Components	Time LEDs are on		
			Min.	Max.	Avg.
1-Minute Fill Cycle	4	WV			1 minute
Harvest Cycle	1, 4, 2	Comp, FMR, WV, HGV	2 minutes	20 minutes	3 to 5 minutes
Harvest Pump Timer	1, 3, 2	Comp, FMR, PM, HGV	0 seconds	50 seconds	harvest pump timer setting
Freeze Cycle	1	Comp, FM/ FMR, PM, HGV	5 minutes	Freeze timer setting	30 to 35 minutes
Pump-out Cycle	1, 4, 3, 2	Comp, FMR, WV*, PM, HGV, SR, DV	10 Seconds	20 Seconds	*pump-out timer setting

The built-in safeties shut down the unit and have alarms as listed below.

No. of Beeps (every 3 sec.)	Type of Alarm	Notes
1	High Evaporator Temp. (Temperature > 127°F / 53°C)	Check for harvest problem (stuck HGV or relay), hot water entering unit, Stuck HM or shorted thermistor.
2	Harvest Backup Timer (harvest > 20 min. for two cycles in a row)	Check for open thermistor, HGV not opening, TXV or LLV leaking by, low charge, inefficient Comp, pr WRV leaking by.
3	Freeze Timer (freeze > freeze timer setting for two cycles in a row)	Check for F/S stuck closed (up), WV leaking by, HGV leaking by, PM not pumping, TXV not feeding properly, LLV not opening, low charge, HM not bypassing or inefficient Comp.
To reset the above safeties, press the "Alarm Reset" button with the power supply ON.		
6	Low Voltage (92Vac+/- 5% or less)	Red LED turns off if voltage protection operates. The control voltage safeties automatically reset when voltage is corrected.
7	High Voltage (147 Vac +/- 5% or more)	

Legend: **Comp**-compressor; **DV**-drain valve; **FM**-Fan motor; **FMR**-fan motor remote; **F/S**-float switch; **HGV**\_hot gas valve; **HM**-headmaster (C.P.R); **LLV**-liquid line valve; **PM**-pump motor; **SR**-service relay; **TXV**-thermostatic expansion valve; **WRV**-water regulating valve; **WV**-water valve.

To preform an output test, first move the control switch to the "ICE" position. Press the "OUTPUT TEST" button. The correct LED lighting sequence is none, 2, 3, 4, 1. Components (e.g., compressor) cycle during the test. Following the test, the ice maker resumes operation. The Dip Switches should be adjusted per the chart in the unit's service manual. S4 dip switch 8 must remain off.

## “H” Board Control Board Lights, Alarms and Test

At startup, a 5 second delay occurs stabilize the circuit. The “POWER OK” LED indicates proper control voltage and remains on unless a control voltage problem occurs. The “POWER OK” LED flashes continuously when the bin is full and PM and DV energize for a maximum of 5 minutes to drain the water tank. LEDs 4 through 9 energize and sequence from initial startup as listed in the table below. Note that the order of LEDs from the outer edge of the board is 5, 6, 8, 9, 4, 7. A copy of this table is located on the unit.

Sequence Step	LED	Energized Components	Time LEDs are on		
			Min.	Max.	Avg.
1-Minute Fill Cycle	8	WV1			1 minute
Harvest Cycle	5, 6, 8	Comp, FMR, HGV, WV1	2 minutes	20 minutes	3 to 5 minutes
Harvest Pump Timer	5, 6, 7	Comp, FMR, PM, HGV	0 seconds	50 seconds	harvest pump timer setting
Freeze Cycle	5, 7 (and 9 at refill)	Comp, FM/ FMR, PM, LLV (WV2 at refill)	5 minutes	Freeze timer setting	30 to 35 minutes
Pump-out Cycle	1, 4, 3, 2	Comp, FMR, HGV, DV, PM*	10 Seconds	20 Seconds	*pump-out timer setting

The built-in safeties shut down the unit and have alarms as listed below.

N o . o f Beeps (every 3 sec.)	Type of Alarm	Notes
1	High Evaporator Temp. (Temperature > 127°F / 53°C)	Check for harvest problem (stuck HGV or relay), hot water entering unit, Stuck HM or shorted thermistor.
2	Harvest Backup Timer (harvest > 20 min. for two cycles in a row)	Check for open thermistor, HGV not opening, TXV or LLV leaking by, low charge, inefficient Comp, or WRV leaking by.
3	Freeze Timer (freeze > freeze timer setting for two cycles in a row)	Check for F/S stuck closed (up), WV1 or WV2 leaking by, HGV leaking by, PM not pumping, TXV not feeding properly, LLV not opening, low charge, HM not bypassing or inefficient Comp.
To reset the above safeties, press the “Alarm Reset” button with the power supply ON.		
6	Low Voltage (92Vac+/- 5% or less)	Red LED turns off if voltage protection operates. The control voltage safeties automatically reset when voltage is corrected.
7	High Voltage (147 Vac +/- 5% or more)	

Legend: **Comp**-compressor; **DV**-drain valve; **FM**-Fan motor; **FMR**-fan motor remote; **F/S**-float switch; **HGV**\_hot gas valve; **HM**-headmaster (C.P.R); **LLV**-liquid line valve; **PM**-pump motor; **TXV**-thermostatic expansion valve; **WRV**-water regulating valve; **WV1**-inlet water valve 1; **WV2**\_inlet water valve 2 (if applicable)

To perform an output test, first move the control switch to the “ICE” position. Press the “OUTPUT TEST” button. The correct LED lighting sequence is 5, 6, 7, 8, 9, 4. Components (e.g., compressor) cycle during the test. Each LED stays on for 5 seconds. LED 5 stays on while LED 6 is on. Following the test, the ice maker resumes operation.

Adjust Dip Switches per the chart in the unit's service manual.

## H Board Dip Switch Designation

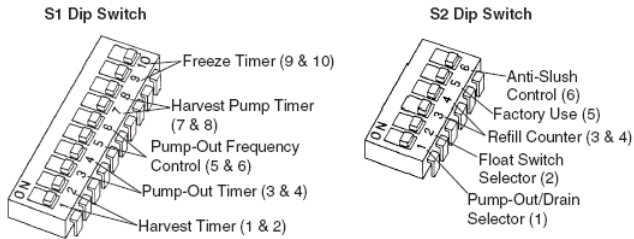

Note: S2 Dips must be set to factory setting by model. DO NOT vary from Factory settings. Dip 5 MUST remain OFF.

### LED's

The H Board can have either 7 or 9 red LED's that light up during the unit operation as indicated by the H Board operation chart.

The LED's are designated as follows:

DS1: Power OK LED

- Comes on 5 seconds after the unit is switched to ICE.
- Indicates proper control voltage (10.5 volts) from the control transformer.
- If the bin control is satisfied (Open), this LED blinks.

DS2: H Timer (Harvest Timer)

- Indicates 2 long (20 minute) harvest back to back
- 2 beep alarm

DS3: F Timer (Freeze Timer)

- Indicated 2 long (time is adjustable) freeze times back to back
- 3 beep alarm

DS4: X6 Relay

- Indicates Drain Valve (DV) is open.
- DV opens for 5 minutes when bin control opens.

DS5: X1 Relay

- Indicates Compressor and Remote Fan Motor are energized.

DS6: X2 Relay

- Indicates Hot gas Valve is energized.
- Energizes the Condenser Fan Motor when OFF.

DS7: Relay X3

- Indicates Pump motor energized

DS8: X4 Relay

- Indicated Harvest Inlet Water Valve is energized.

DS8: X5 Relay

- Indicated Refill/Freeze Water Valve is energized
- Service board only

## COMPRESSOR DATA

Remote units use -02 compressor which has crankcase heater.		LRA = Lock Rotor Amperage		RWR = Run Winding Resistance			
H series models, Models with * use R134A, all others use R404A. -E or 50 = European model / 50 hz.		SWR = Start Winding Resistance		RLA = Running Load Amperage (see performance data)			
Resistance is measured with wheatstone bridge under controlled ambient conditions.							
Model	Part #	Manufacturer #	LRA	SWR (Ohms)	RWR (Ohms)	Oil Type	Oil Chg. (Fl.oz./cc)
*AM-100BAE	464330-01	Panasonic	31	7.51	1.18	POE EAL	8.5/250
*AM-150BAF	4A2272-01	Copeland	39	7.3	1.2	POE EAL	15/444
* KM-61BAH, *AM-50BAE	P00023-01	Panasonic	14.5	9.69	2.41	FREOL	8.5/250
* KM-101BAH	P00024-01	Panasonic	23.1	7.93	1.41	FREOL	8.5/250
KM-151BAH	P00025-01	Panasonic	30.7	7.53	1.06	FREOL	8.5/250
KM-201BAH	P01130-01	Danfoss	28	5.4	1.7	POE EAL	10.8/320
KML-250M/KM-320M	4A2456-01	Copeland	33.6	7.3	1.2	POE EAL	12/355
KM-251BAH, KM-255BAH	4A3677-01	Danfoss	53	2.9	0.7	POE EAL	20.3/600
KM-260BAH	P01081-01	Danfoss	41.9	4.3	1	POE EAL	18.6/550

## COMPRESSOR DATA

Remote units use -02 compressor which has crankcase heater.		LRA = Lock Rotor Amperage		RWR = Run Winding Resistance			
H series models, Models with * use R134A, all others use R404A. -E or 50 = European model / 50 hz.		SWR = Start Winding Resistance		RLA = Running Load Amperage (see performance data)			
Resistance is measured with wheatstone bridge under controlled ambient conditions.							
Model	Part #	Manufacturer #	LRA	SWR (Ohms)	RWR (Ohms)	Oil Type	Oil Chg. (Fl.oz./cc)
KM-280M	4A1812-01	Tecumseh	58.8	4.22	0.59	POE EAL	17.3/512
KM-280MAH-E	4A1924-01	Tecumseh	58.8	4.22	0.59	POE EAL	17.3/512
KM-320MAH-E	4A4426-01	Copeland	15.8	14.15	5.7	POE EAL	12/355
KML-351M, KM-461M, KML-451MAH	4A2300-01	Copeland	51	4.08	0.59	POE EAL	24/710
KMD-410M	P01550-01	Embraco	50	2.62	0.51	POE EAL	15/444
KMD-450M, KMD-460M	4A4479-01	Copeland	54.5	2.66	0.43	POE EAL	15/444
KML-450 MAH, DKM-500B	4A1843-01	Copeland	60	4.2	0.66	POE EAL	24/710
KM-450M, KML-350M	4A2300-01	Copeland	51	4.08	0.59	POE EAL	24/710
KM-500M, KM-501M	4A1820-01	Tecumseh	50	5.95	0.69	POE EAL	17.3/511
KM-500MAH-E	4A1925-01	Tecumseh	26.3	7.149	2.746	POE EAL	17.3/512

## COMPRESSOR DATA

Remote units use -02 compressor which has crankcase heater.		LRA = Lock Rotor Amperage		RWR = Run Winding Resistance			
H series models, Models with * use R134A, all others use R404A. -E or 50 = European model / 50 hz.		SWR = Start Winding Resistance		RLA = Running Load Amperage (see performance data)			
Resistance is measured with wheatstone bridge under controlled ambient conditions.							
Model	Part #	Manufacturer #	LRA	SWR (Ohms)	RWR (Ohms)	Oil Type	Oil Chg. (Fl.oz./cc)
KM-515M, KMD-530M, KM-600M, KML-451MWH	4A4376-01	Copeland	70	2.6	0.4	POE EAL	15/444
KM-515MAH-E, KM-650MAH-E	4A4462-01	Copeland	38	8.31	1.63	POE EAL	15/444
KML-600M, KMD-700M	4A1539-01	Copeland	56	3.044	1.107	POE EAL	45/1331
KM-630MAH Serial MI	4A2302-01	Copeland	37	7.92	1.55	POE EAL	24/710
KM-630MAH-E Serial M2 >	4A2301-01	Copeland	33	7.002	1.82	POE EAL	24/710
KML-631M, KMD-850M	4A4066-01	Copeland	54	3.044	1.107	POE EAL	35/1035
KM-650M_H	4A4072-01	Copeland	40	3.82	3.09	POE EAL	24/710
KMD-901MW/R, KML-600M, KMD-700M	4A1539-01	Copeland	56	3.044	1.107	POE EAL	45/1331
KM-900M, KMD-900M, KM-1300M/S, KM-1340M	4A1412-01	Copeland	61	2.594	0.999	POE EAL	45/1279

## COMPRESSOR DATA

Remote units use -02 compressor which has crankcase heater.		LRA = Lock Rotor Amperage		RWR = Run Winding Resistance			
H series models, Models with * use R134A, all others use R404A. -E or 50 = European model / 50 hz.		SWR = Start Winding Resistance		RLA = Running Load Amperage (see performance data)			
Resistance is measured with wheatstone bridge under controlled ambient conditions.							
Model	Part #	Manufacturer #	LRA	SWR (Ohms)	RWR (Ohms)	Oil Type	Oil Chg. (Fl.oz./cc)
KM-900MAH-50, KM-1300/1301SAH-E	4A1749-01	Copeland	58	2.646	1.346	POE EAL	45/1331
KM-900MIRH3, KM-1300/1301SAH3	4A1484-02	Copeland	55	Line to Line 1.609		POE EAL	45/1331
KMD-901MAH, KM-901M, KM-1301SRW, KM-1400SWH-M	4A4134-01	Copeland	56	3.044	1.107	POE EAL	45/1331
KM-901MRH3	4A4135-02	Copeland	51	Line to Line 1.77		POE EAL	45/1331
KM-1301SW/R3, KM-1400SWH3-M	4A4135-01	Copeland	51	Line to Line 1.77		POE EAL	45/1331
KM-1600MRH/SRH	4A1420-02	Copeland	96	2.333	0.623	POE EAL	45/1331
KM-1600M3/S3	4A1419-02	Copeland	75	Line to Line 1.058		POE EAL	45/1331
KM-1601MRH, KM-1601S, KM-1800S	4A2334-02	Copeland	82	2.82	0.715	POE EAL	45/1331
KM-1601MRH3, KM-1601S3, KM-1800S3	4A2330-02	Copeland	65.5	Line to Line 1.256		POE EAL	45/1331



## COMPRESSOR DATA

Remote units use -02 compressor which has crankcase heater.	LRA = Lock Rotor Amperage	RWR = Run Winding Resistance
H series models, Models with * use R134A, all others use R404A. -E or 50 = European model / 50 hz.	SWR = Start Winding Resistance	RLA = Running Load Amperage (see performance data)

Resistance is measured with wheatstone bridge under controlled ambient conditions.

Model	Part #	Manufacturer #	LRA	SWR (Ohms)	RWR (Ohms)	Oil Type	Oil Chg. (Fl.oz./cc)
KM-1900SAH350	4A4372-01	Copeland	33	Line to Line 4.951		POE EAL	45/1331
KM-1900S, KMH-2000S	4A4581-01	Copeland	73	2.131	0.847	POE EAL	45/1331
KM-1900S3,	4A4582-01	Copeland	66	Line to Line 1.256		POE EAL	45/1331
KM-2000S3, KM-2100S3, KMH-2000S3	4A1419-01	Copeland	75	Line to Line 1.256		POE EAL	45/1331
KM-2100S_H350	4A4730-01	Copeland	40	Line to Line 4.110		POE EAL	45/1331
KM-2400SRH3	4A2043-01	Maneurop	12.5	Line to Line 0.62		POE EAL	61/1804
KM-2500SWH3	4A4486-01	Copeland	105	Line to Line 0.853		POE EAL	45/1331

## COMPRESSOR DATA

Remote units use -02 compressor which has crankcase heater.		LRA = Lock Rotor Amperage		RWR = Run Winding Resistance			
H series models, Models with * use R134A, all others use R404A. -E or 50 = European model / 50 hz.		SWR = Start Winding Resistance		RLA = Running Load Amperage (see performance data)			
Resistance is measured with wheatstone bridge under controlled ambient conditions.							
Model	Part #	Manufacturer #	LRA	SWR (Ohms)	RWR (Ohms)	Oil Type	Oil CHG (Fl Oz./cc)
KM-2500SRH3	4A4782-01	Maneurop	135	Line to Line 0.55		POE EAL	63/1863
SRK-7H	4A4066-01	Copeland	54	3.044	1.107	POE EAL	35/994
SRK-8H	4A1539-03	Copeland	56	3.044	1.107	POE EAL	45/1331
SRK-8H3	4A5339-01	Copeland	51	Line to Line 1.770		POE EAL	45/1331
SRK-12H	4A4134-03	Copeland	56	3.044	1.107	POE EAL	45/1331
SRK-12H3	4A4135-03	Copeland	51	Line to Line 1.77		POE EAL	45/1331
SRK-13H, SRK-14H	4A2334-02	Copeland	82	2.82	0.715	POE EAL	45/1331
SRK-14H3	4A2330-02	Copeland	66	Line to Line 1.168-1.344		POE EAL	45/1331
SRK-14J	4A4582-01	Copeland	66	Line to Line 1.256		POE EAL	45/1331
SRK-14J3	4A4581-01	Copeland	73	2.131	0.847	POE EAL	45/1331
SRK-20H	4A4888-01	Copeland	121	2.302	0.500	POE EAL	45/1331
SRK-20H3	4A4589-01	Copeland	105	Line to Line 0.853		POE EAL	45/1331

## SUBSTITUTE COMPRESSOR DATA

IF ORIGINAL COMPRESSOR SUBS, USE INFORMATION BELOW FOR SUBSTITUTE PART NUMBER OR LOCATE PART NUMBER ON PREVIOUS CHARTS.

Remote units use -02 compressor which has crankcase heater.		LRA = Lock Rotor Amperage		RWR = Run Winding Resistance				
H series models, Models with * use R134A, all others use R404A. -E or 50 = European model / 50 hz.		SWR = Start Winding Resistance		RLA = Running Load Amperage (see performance data)				
Resistance is measured with wheatstone bridge under controlled ambient conditions.								
Original Compressor part number	Part #	Manufacturer #	LRA	SWR (Ohms)	RWR (Ohms)	Oil Type	Oil Charge (Fl.Oz./cc)	
Subs for 4A1272-01, 4A2300-01, 4A1726-07, SA0038, SA0138	4A1726-40	Copeland	RS43C1E-CAA	54.5	2.66	0.43	POE EAL	15/440
Subs for 4A4072-01, SA0043, SA0143	4A5079-01	Copeland	RST61C1E-CAV	36	6.26	1.34	POE EAL	15/440
Subs for 4A2300-01	4A5090-01	Copeland	RST40C1E-CAA	50	2.62	0.51	POE EAL	15/440
Subs for 4A1843-01	4A5158-01	Copeland	RST61C1E-CFA	77	2.391	0.36	POE EAL	15/440
Subs for 4A4066-01, 4A1726-33	3A6900-01	Copeland	RST70C1E-PFV					
Subs for 4A4486-01	4A5093-01	Copeland	CS27K6E-1F5-230	105	Line to Line 0.853		POE EAL	45/1331

## Water-Cooled Head Pressure Controls:

An adjustable (Pressure Modulated) water-regulating valve is installed on the water-cooled condenser **outlet**. This is unique to Hoshizaki water-cooled products and maintains cleaner operation and instant condenser cooling at start-up. A #V46, Johnson Controls Penn valve, is used. The Penn valve is identified by a label on the valve housing.

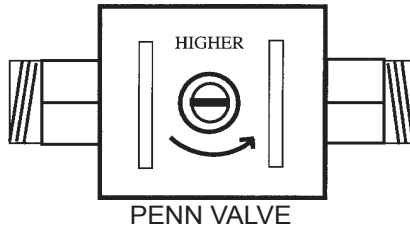

ADJUSTMENT CONTROLS	
CW	lower pressure and outlet water temperature with higher water flow
CCW	higher pressure and outlet water pressure with lower water flow

CONDENSER OUTLET WATER TEMPERATURE RANGE		
Model	Range	High side pressure
All KM	104 ~ 115 °F	270 psig.
All DCM	100 ~ 104 °F	260 psig.
All F	100 ~ 104 °F	260 psig.

If the water-cooled unit has been in operation for a long period of time, adjusting the water-regulating valve may not allow proper pressures.

In this case: the water-cooled condenser likely contains an exorbitant amount of scale and requires cleaning.

An acid based condenser cleaner should be circulated using an acid pump, in reverse flow through the coil until the inner tube is free of scale. Once the scale is removed, the water-regulating valve should be adjusted to maintain the range and pressure listed above

## Remote Head Pressure Control:

All remote condenser units utilize a condensing pressure regulating (CPR/Headmaster) valve to maintain head pressure in low ambient conditions.

Condenser/Unit	Headmaster
SRK-10H/12H/14H/14J	LAC 4-160
URC-5F/9F/14F/21F/22F, SRC-14H, SRK-20H, KM-2500S	LAC 4-190
URC-6F/7F/12F/20F, SRC-10H, SRK-7H/13H	LAC 4-210
KM-2400S	LAC 5-210

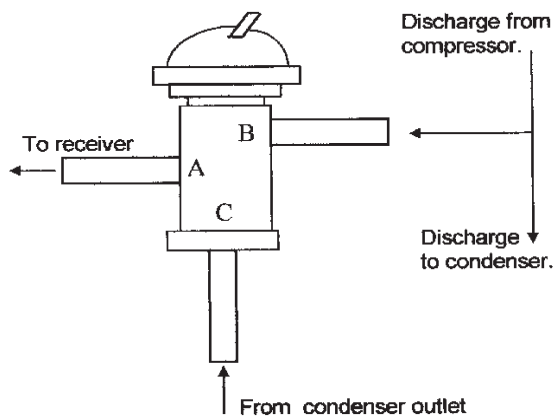

The symptoms of a bad headmaster are similar to those of an undercharged unit. Many valves are changed unnecessarily due to a low charge.

### To diagnose a bad headmaster:

Add additional refrigerant in 2 lb. increments and watch the pressures. If the pressures begin to look normal, the unit was undercharged.

**In this case:** Leak check the system to find the leak.

Use normal refrigeration practices to recover, repair, evacuate and recharge the unit.

**If not:** A bad headmaster is a possibility.

Check to see if the valve is stuck open by conducting temperature checks at the outlet of the headmaster.

Replace the headmaster as necessary.

Use safe refrigeration practices when removing the valve and protect the valve from overheating.

## High Pressure Safety Switch:

An automatic reset high pressure safety switch is utilized on all Hoshizaki ice makers. The typical high pressure switch is an automatic reset switch with a long capillary tube. **In the future, this switch will be changed to a stub style switch with a large diameter pipe instead of a capillary tube.** Look for this stub HP switch on recent and future production.

Pressure switch part numbers & settings are as follows:

<b>Pressure Switch Chart R-404A Models</b>			
<b>Capillary type</b>			
<b>Models</b>	<b>part number</b>	<b>cut out (psig.)</b>	<b>cut in (psig.)</b>
All KM & DCM water-cooled, DCM-270, and Flaker	433441-05	384 ± 21.3	284 ± 21.3
DCM-500/750BAF All KM Air & Remote	433441-07	412 ± 21.3	327 ± 21.3

<b>Stub Type</b>			
<b>Models</b>	<b>part number</b>	<b>cut out (psig.)</b>	<b>cut in (psig.)</b>
KM Air & Remote	463180-04	412 ± 21.3	327± 21.3
KM Water	463180-05	384 ± 21.3	284± 21.3

## Bin Control:

KM cubers will use one of three types of bin controls. The type of bin control will vary depending on the unit style, or model and serial number.

### 1. Thermostatic Bin Control:

The thermostatic bin control (TBC) is the primary control that supplies 115 volts to all major components in the unit, except the compressor. When this control is closed, 115V is supplied to the control transformer and the K1 control board connector (the board switches 115 volts to the components as the sequence dictates).

A thermostatic capillary bulb is mounted in the ice drop zone area or on a drop down bracket which extends into the bin

cavity. The TBC opens on temperature drop and closes on temperature rise. When ice touches the thermostatic bulb, the bulb pressure opens the bin control contacts to shut the unit down. The unit will not operate in the ICE or WASH position, **unless** the TBC switch is closed.

The TBC will shut the unit down at any point in the sequence of operation if ice contacts the control bulb. Shut down time depends on the control adjustment. This adjustment is factory set, however it should **always** be checked at start-up or after replacement to assure proper operation. The factory setting is to shut off within 3~10 seconds after ice contacts the bulb.

**NOTE: High altitude areas require adjustment.**

When ice is moved away from the bulb, the unit will always restart during the 1-minute fill cycle.

Larger M and S models include a drop down bulb bracket. This bracket should be secured to the unit base and the control plug connection **must be made** before the unit will operate. A bin control extension bracket is included with all S models. It is secured to the drop down with a wire tie. Be sure to install the extension bracket. When installing, make sure the bracket points downward, with the elbow joint facing out so that the cubes will easily fall away from the bin control bulb as shown in the following illustration.

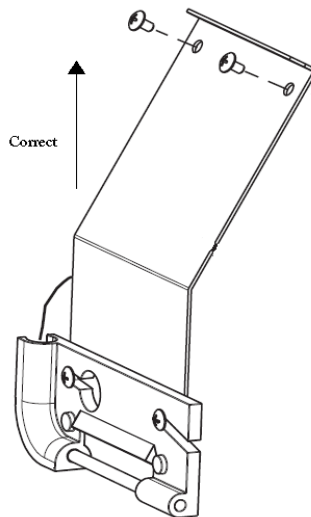

## Bin Control Extension Brackets:

Various bin control extension brackets are available for special applications. These may be necessary in certain applications to reduce ice meltage around the bin control. This can occur in applications with low usage and in dispenser applications. While most are special order parts, some models include an extension bracket specifically for use on dispenser applications.

Application chart for various extension brackets:

Part #	Application	Control Height
1. HS-0239 > Standard on 22" KM models	Dispenser or low usage on bin. For MBC or TBC.	Adjust to 3" below unit. (ABS)
2. 3A7049-01 > Optional for use on KM Modular units.	Longer HS-0239 for dispenser or low usage on bin. For MBC or TBC.	Adjust to 6" below unit. (Stainless)
3. 4A4633-01 or HS-0239 > Optional	For 2 > KM-1340/1601M mounted on upright bin. For TBC only.	Lowers control 3" to reduce ice cavity (4A4633-01 is Stainless)
4. HS-0207 > Standard on certain KMD/KMS models. Optional for DKM and other models.	Dispenser or low usage on bin. For T-stat only. For MBC only.	Adjust to 3" below unit. (Stainless)
5. HS-5062 > Optional	Longer HS-0207 for dispenser or low usage on bin. For MBC only.	Adjust to 6" below unit. (Stainless)
6. HS-0246 / 3A5210-02 KM-901M only.> Optional	Low usage on bin. For MBC only.	Adjust to 6" below unit. (Stainless)
7. 3A8319-01 > Optional	Relocate TBC or MBC for low usage on bin.	Adjustable down to 10"... Hangs on side of bin. (Stainless)

## Illustrations:

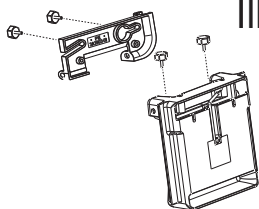

HS-0239 on KM-1340M application.

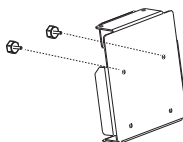

1. HS-0239  
Use with TBC or MBC.

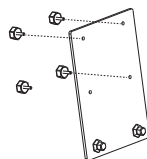

2. 3A7049-01



## Extension Bracket Illustrations:

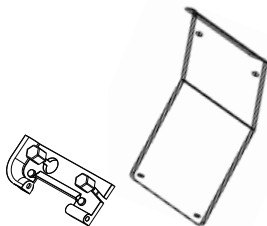

3. 4A4633-01

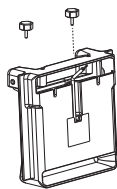

4. HS-0207

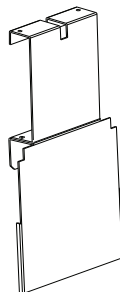

5. HS-5062

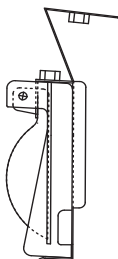

Standard  
KM-901 Bracket.

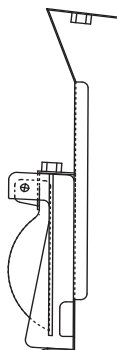

6. HS-0246

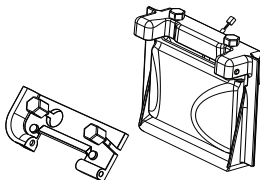

7. 3A8319-01  
Use with TBC or MBC.

### **When replacing a thermostatic bin control:**

Check the operation by holding ice against the thermostatic bulb with the control switch in the wash position.

The pump should stop within 3 to 10 seconds. Adjustment up to 30~45 seconds is acceptable, depending on the application. Adjust the control "CCW" for a faster shut down.

**Note:** Control board dip switch number 7 must be OFF for this control to operate the unit. A TBC may be used on KML models.

## **2. Mechanical Bin Control:**

Currently, KMD/KMS and some M models use a mechanical bin control (MBC). This control includes a proximity switch and actuator paddle assembly. ***MBC is currently being implemented on larger M and S models as well. For S models, 1 MBC will operate both stacked heads through a wiring harness supplied with the unit.***

The MBC assembly mounts in the ice drop zone area and will shut the unit down within 5 to 15 seconds when ice pushes the actuator paddle to the full right position.. Shut down will only occur during the first 5 minutes of the freeze cycle when the paddle closes (magnet pivots away from the switch and the proximity switch opens). If the paddle is closed and held at any other time during the sequence, the unit will continue to run until the next freeze cycle occurs.

This feature allows for a full batch of ice every cycle so that there are no small cubes in the bin.

A resistor wiring harness connects the MBC to the red K4 connector on the E control board. As the proximity switch opens and closes, the resistance value will change to either start up or shut down the unit.

- a) When the control paddle is hanging in the normal position, the resistance at the red K4 connector will be 7.9 K ohms and the unit will start.

### **BIN EMPTY:**

**On E Board** - MBC in the normal position supplies 7.9 K ohms at red K4 connector to start unit.

**On G Board** - No resistance is used. Green LED marked "BC CLOSED" will light.

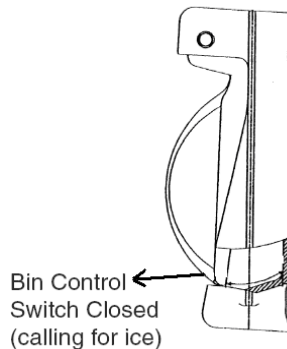

b) When the paddle is held to the right, the resistance at the K4 red connector will be 15.8 K ohms and the unit will shut down within 3 seconds during the first 5 minutes of the freeze cycle. It will not shut down at any other time in the sequence of operation.

**BIN FULL:**

**On E Board** - MBC in full right position supplies 15.8K ohms at red K4 connector to shut unit down.

**On G Board** - No resistance is used. Yellow LED marked "BC OPEN" will light.

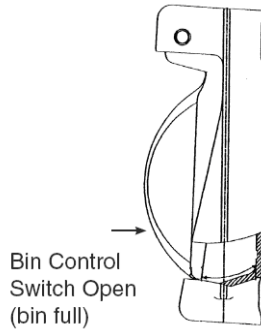

**Note:** On E control board dip switch number 7 must be ON for this control to operate the unit.

**Mechanical Bin Control with G Board**

The "G" board does not require a resistor wiring harness for MBC operation. A wiring harness connector without resistors is required (Part Number 4A2200G05). An open circuit on the red K4 connector will shut the unit down within the first 5 minutes of the freeze cycle. A closed circuit on the red K4 connector will start the unit in the 1 minute fill cycle. The "G" board has LED's that indicate the status of the MBC

**BC OPEN (yellow)** = open bin control, calling for shut down.  
**BC CLOSED (green)** = closed bin control, calling for ice.

When the actuator is in the closed position, the switch will close the K4 connector and the green LED will light. This indicates that the unit should be in the ice making mode.

**Note:** If unit is converted to TBC for any reason, the K4 connector must be jumped in order to start the unit. Use special jumper # 4A4883G01 for K4 red connector.

**Mechanical Bin Control with H Board**

H board has different connectors and does not require resistors to switch the board operation. The mechanical proximity switch will open to shut the unit down when ice fills and pushes actuator over the same as the G board operation. When ice is moved, the switch closes and the unit starts.

## KM Cuber Sequence Of Operation:

**Note:** When power is supplied to the “E” or “G” Control board, a 10 second delay occurs at start-up. The board checks power for 5 seconds and the red “POWER OK” LED lights. The board checks for alarms and 5 seconds later the unit starts.

The general steps in the operation sequence are as follows:

### 1. 1 Minute Fill Cycle:

The unit always starts with the 1 minute fill cycle. When power is applied to the unit, the water, or refill, valve is energized and the fill period begins.

After 1 minute the board checks for a closed float switch. If the float switch is closed the harvest cycle begins.

If not, the unit will not start without adequate water in the reservoir. This serves as a low water safety.

The water valve will remain energized through additional 1 minute cycles, until water enters the reservoir and the float switch closes.

### 2. 1st Harvest Cycle:

The compressor starts, hot gas valve opens, water valve remains open and harvest begins.

As the evaporator warms, the thermistor located on the suction line checks for a 48° F. temperature. When 48° F. is reached, the harvest is turned over to the adjustable control board defrost timer which is factory set for normal conditions. This adjustment can vary the defrost timer from 1 to 3 minutes.

**Note:** This note explains the new **positive harvest feature**.

1. On the “G” board, the pump starts 50 seconds before the end of the harvest. This is factory set by the S5 dip switches. DO NOT ADJUST these dip switches.

2. On H board, the pump starts 30 seconds before the end of harvest.

3. The H board can be adjusted to allow for pump operation 0, 10, 30, or 50 seconds before the end of harvest. This is adjustable with S2 dip switches. Dip switches on S2 should remain at factory settings.

### 3. Freeze Cycle:

After the harvest timer terminates the harvest cycle, the hot gas and water valves close, and the ice production cycle starts. For the first 5 minutes the controller board will not accept a signal from the float switch. This 5 minute minimum freeze acts as a short cycle protection. After 5 minutes, the float switch assumes control.

**Note:** In some newer models, a refill will occur during the freeze cycle. This is controlled by a second float switch and the board settings.

As ice builds on the evaporator, the water level in the reservoir lowers. The freeze continues until the float switch opens and terminates ice production.

### 4. Harvest Pump Out:

When the float switch opens and signals the completion of the freeze cycle, the harvest cycle begins. The hot gas valve opens and the compressor continues to run. The drain timer starts counting the 10/20 second pump out. The water pump stops for 2 seconds and reverses, taking water from the bottom of the reservoir and forcing pressure against the check valve seat, allowing water to go through the check valve and down the drain. At the same time, water flows through the small tube to power flush the float switch. When the drain timer stops counting, the pump out is complete.

On the E & H boards, pump out always occurs on the 2nd harvest after startup. These control boards allow for adjustment, so pump out occurs every cycle, or every 2nd, 5th or 10th cycle from this point.

**Note:** On G board, the first pump out will vary depending on the adjustment of S4 dip switches 5 & 6. It does not occur on the second harvest as mentioned above.

### 5. Normal Harvest Cycle:

The water valve opens to allow water to assist the harvest. As the evaporator warms, the thermistor reaches 48° F. the control board receives the thermistor signal of 3.9 K ohms or less and starts the defrost timer. The water valve is open during harvest (defrost) for a maximum of 6 minutes, or the length of harvest, whichever is shorter. When the defrost timer completes its count down, the defrost cycle is complete and the next freeze cycle starts. The unit continues to cycle through sequence steps 3, 4, and 5 until the bin control senses ice and shuts the unit down.

## Basic KM Sequence Flow Chart and Component Operation

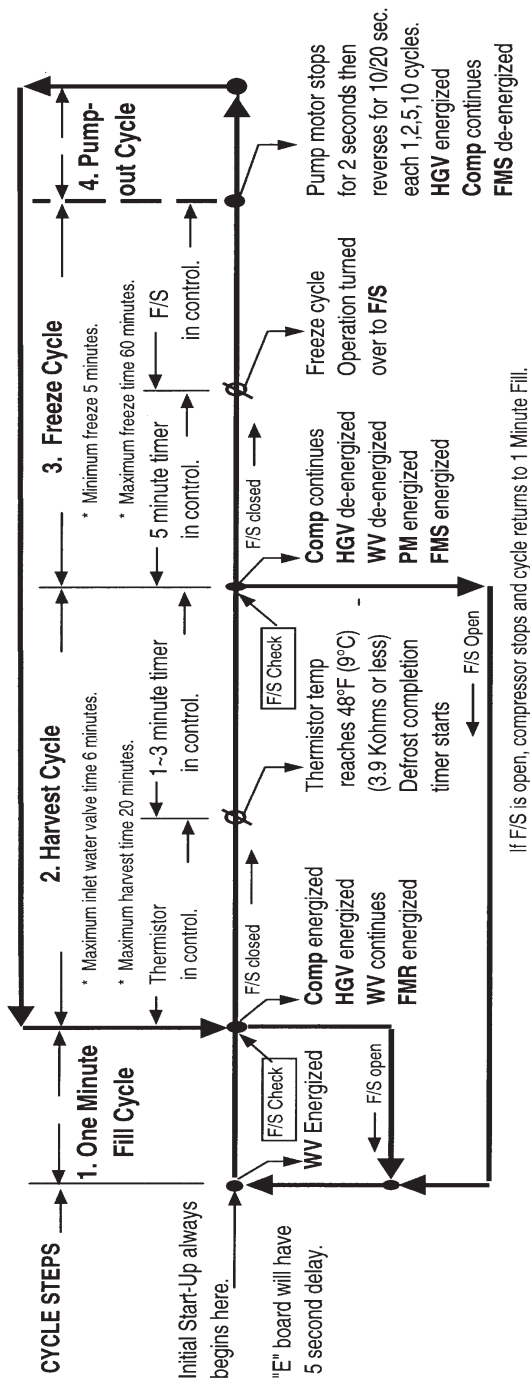

<b>Legend:</b> Comp - compressor	FMS - self-contained fan motor	HGV - hot gas valve	WV - inlet water valve
FMR - remote fan motor	F/S - float switch	PM - pump motor	

# KM-251/255BAH and KM-255BWH Sequence Flow Chart and Component Operation

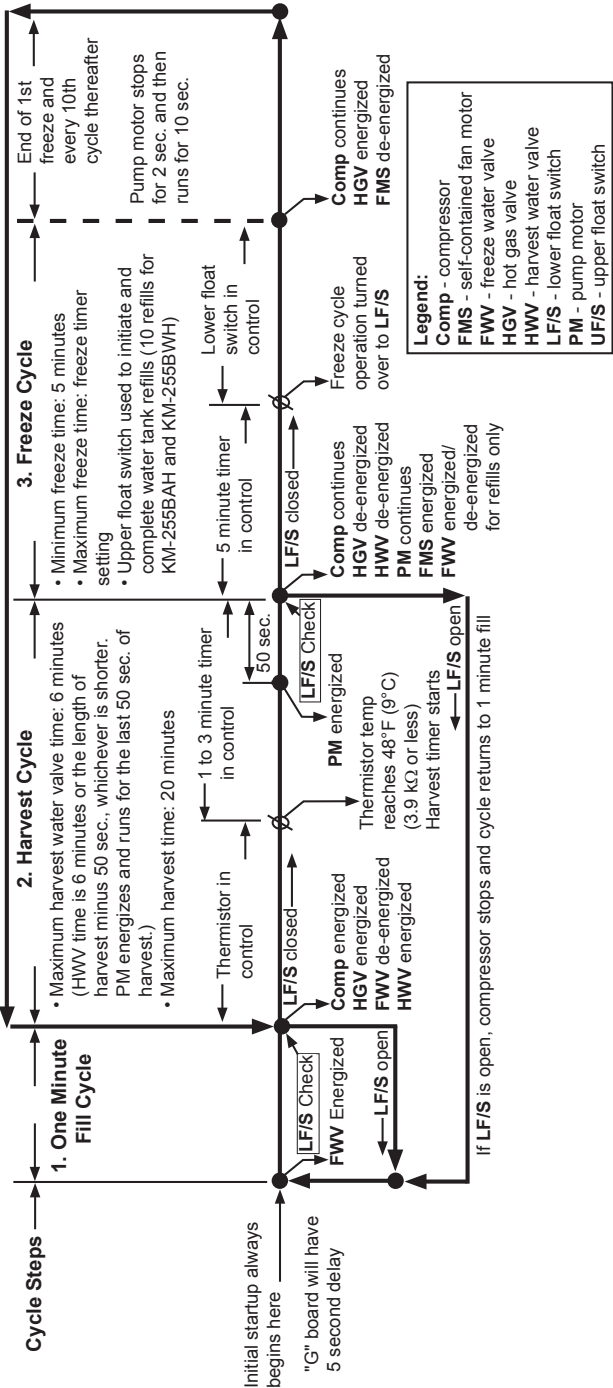

# KM-61~260B and Small KMD with "H" Control Board Sequence Flow Chart

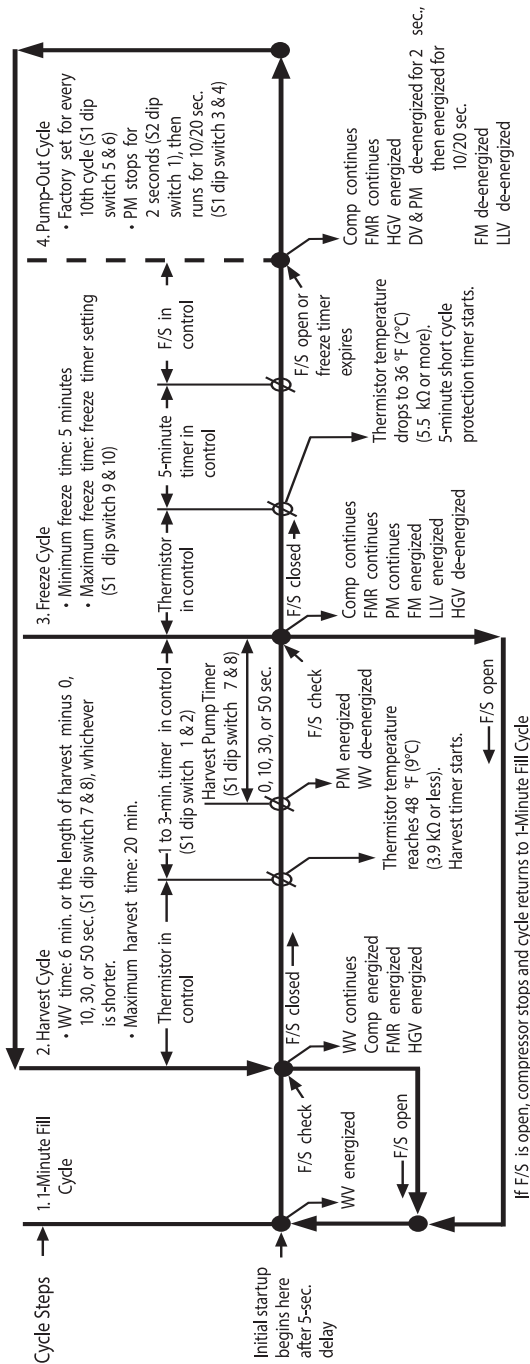

\*

\*NOTE: On KM-61/101/151, pump stops during pumpout and reservoir drains by gravity.



# KMS-750/1230/1400/1401MLH Sequence Flow Chart and Component Operation

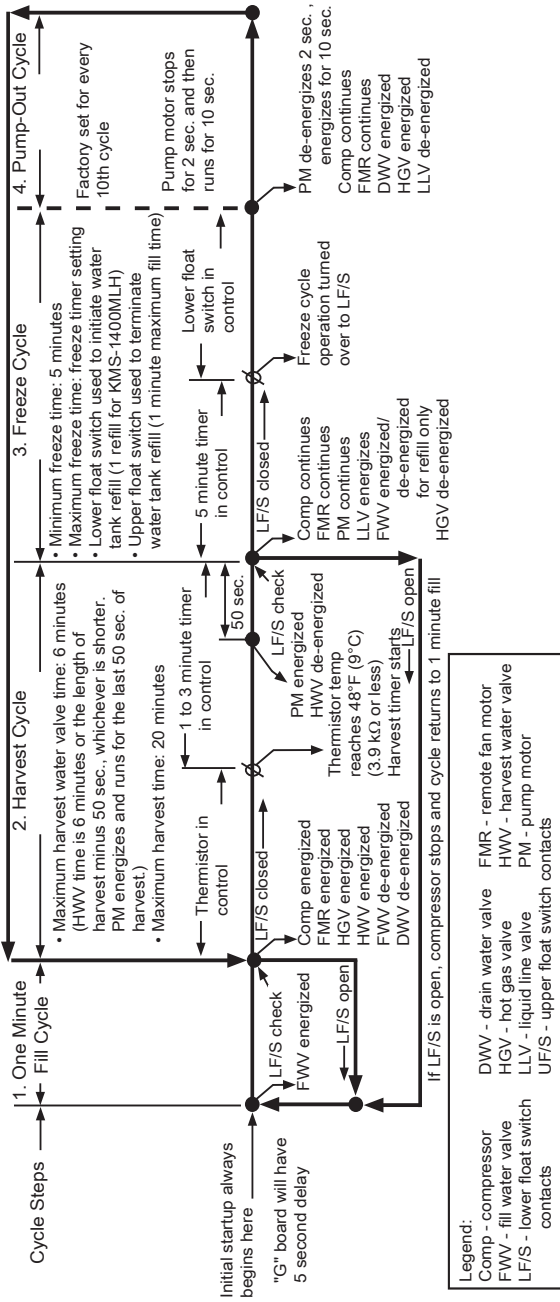

## Basic Check Out Procedure, E & H Boards:

The 10 minute check out procedure is a sequence check that can be used at unit start-up or for system diagnosis. Using this check out procedure will allow you to diagnose electrical system and component failures in approximately 10 minutes (under normal operating conditions of 70°F or warmer air and 50°F or warmer water temperatures).

### Before conducting a 10 minute checkout:

1. Check for correct installation and proper supply voltage.
2. Adequate water supply and clean evaps and condenser.
3. Control board dips 7 & 8 in correct position.

As you go through the procedure, check to assure the components energize and de-energize correctly. If not, those components and controls are suspect.

## 10 Minute Check Out Procedure

1. Turn power OFF - gain access to unit control box.
2. Turn power ON – place control switch in ICE position.

**Note:** A 5 second delay occurs due to board safety checks.

### A) 1 Minute Fill Cycle begins – **WV** energized.

After 1 minute, control board checks **FS**.

If **FS** is closed: unit cycles to harvest. Continue to (B).

If **FS** is open: unit repeats 1 minute fill cycle until water enters and **FS** closes (low water safety protection during initial start up and at the end of each harvest).

#### Diagnosis

If **WV** does not open: check for no supply voltage at **WV** terminals, bad coil, or plugged screen or external filter (no water flow). If unit fails to start harvest: check for open **FS** or bad 1 minute timer in board.

### B) Initial Harvest Cycle – **WV** remains energized

**CC** energizes to start **C**, **HGV**, & energize (**FM**, on remote model).

Evaporator warms, thermistor senses 48°F and turns operation of harvest to control board defrost completion timer. Timer completes counting (1~3 minutes) and the unit cycles in order to freeze. On H models, **WV** stops and pump starts for last 30 seconds of harvest.

#### Diagnosis

Check to see if **C** is running, **HGV** is open, and **WV** is still open. Avg. harvest cycle at factory setting is 2 ~ 3 minutes. How long does initial harvest last? 1.5 minutes after initial harvest begins, touch **C** discharge line. Is it hot? If no, check refrigerant pressures and **C** operation. If yes, touch inlet line to the evaporator. Is it hot? If yes, but unit is not starting freeze cycle, check: defrost completion timer adjustment,

thermistor (for open circuit), discharge line temperature, **C** efficiency, and that **HGV** is fully open.

- C) Freeze cycle** – **C** remains energized, **PM**, (**LV** on **RS** model), and **FM** energize. **WV** & **HGV** de-energize. Unit is held in freeze by 5 minute short cycle protection timer. After 5 minutes, freeze cycle operation is transferred to **FS** for freeze termination. During first 5 minutes of freeze, confirm that evaporator temperature drops. After 7 minutes in freeze, remove black **FS** lead from **K5** connector. Unit should immediately switch to pump out cycle. (Drain water from the reservoir to allow **FS** to open normally to verify **FS** operation.)

#### **Diagnosis**

If evaporator is not cold, check for **HGV** still open, **TXV** not opening properly, **WV** continuing to fill reservoir, improper unit pressures, and inoperative/inefficient **C**. If unit remains in freeze with **FS** removed replace board. \* Normal freeze cycle will last 20 ~ 40 minutes depending on model and conditions. Cycle times and pressures should follow performance data provided in this handbook or unit service manual.

- D) Pump Out Cycle** – In this 10/20 second pump out, **C** remains energized, **HGV** energizes, **FM** de-energizes, **PM** stops for 2 seconds and starts in reverse rotation for 10/20 seconds.

This removes contaminants from the water reservoir, through check valve, down the drain and allows for power flush of **FS**.

Check clear tubing at check valve housing, or unit drain, for water flow.

#### **Diagnosis**

If **PM** does not reverse, check **PM** circuit and capacitor. If water does not pump out, remove housing and check/clean valve assembly.

- E) Normal Harvest Cycle** – This is the same as Initial Harvest Cycle. Return to B) and unit cycles through B), C), & D) until bin control is satisfied or power is switched OFF.

**Note:** Setting can be adjusted to skip D until every 2, 5, or 10 cycles and the unit always restarts at A).

#### **Legend:**

**C** – Compressor, **CC** – Contactor Coil, **FM** – Condenser Fan Motor  
**FS** – Float Switch, **HGV** – Hot Gas Valve, **LV** – Line Valve  
**PM** – Pump Motor, **RS** – Remote System, **WV** – Inlet Water Valve  
**TXV** - Thermostatic Expansion Valve,

## Check Out Procedure for G Boards:

The G Board check out procedure requires additional time due to different features in the sequence. This sequence check can be used at unit start-up or for system diagnosis. Using this check out procedure will allow you to diagnose electrical system and component failures in approximately 15 minutes (under normal operating conditions of 70°F or warmer air and 50°F or warmer water temperatures).

### 15 Minute G Board Check Out Procedure:

1. Turn power OFF - gain access to unit control box.
2. Change S4 Dip switched 5 & 6 OFF for 1/1 pumpout.  
(Note that this is the max cleaning setting...Most G board units are set on 1/10 however this will allow a pumpout to occur after the 2nd freeze cycle and every cycle thereafter for checkout purposes. **After checking, reset to factory setting or leave off for maximum flush/cleaning**)
3. Turn power ON – place control switch in ICE position.

**Note:** A 5 second delay occurs due to board safety checks.

#### A) 1 Minute Fill Cycle begins – WV energized.

After 1 minute, control board checks FS.

If FS is closed: unit cycles to harvest. Continue to (B). If FS is open: unit repeats 1 minute fill cycle until water enters and FS closes (low water safety protection during initial start up and at the end of each harvest).

#### Diagnosis

If WV does not open: check for no supply voltage at WV terminals, bad coil, or plugged screen or external filter (no water flow). If unit fails to start harvest: check for open FS or bad 1 minute timer in board.

#### B) Initial Harvest Cycle – WV remains energized

CC energizes to start C, HGV, & energize (FM, on remote model).

Evaporator warms, thermistor senses 48°F and turns operation of harvest to control board defrost completion timer. Timer completes counting (1~3 minutes) and the unit cycles in order to freeze.

**Note:** For units with the Harvest Assist feature turned on (**harvest relay and S4 # 7 ON**) WV will de-energize 50 seconds before the end of harvest and PM will energize to clear remaining ice.

#### Diagnosis

Check to see if C is running, HGV is open, and WV is still open. Avg. harvest cycle at factory setting is 2 ~ 3 minutes. How long does initial harvest last? 1.5 minutes after initial harvest begins, touch C discharge line. Is it hot? If not, check refrigerant pressures and C operation. If yes, touch inlet line to the evaporator. Is it hot? If yes but unit is not starting freeze cycle, check: defrost completion timer adjustment, thermistor

(for open circuit), discharge line temperature, **C** efficiency, and that **HGV** is fully open.

- C) Freeze cycle** – **C** remains energized, **PM**, (**LV** on **RS** model), and **FM** energize. **WV** & **HGV** de-energize. Unit is held in freeze by 5 minute short cycle protection timer. After 5 minutes, freeze cycle operation is transferred to **FS** for freeze termination. During first 5 minutes of freeze, confirm that evaporator temperature drops.

After 6 minutes in freeze, drain water and allow **FS** to drop (to test **FS** operation) or remove **FS** lead from K5 connector. Unit should switch to **B) Harvest** after 15 seconds.

#### Diagnosis

If evaporator is not cold, check for **HGV** still open, **TXV** not opening properly, **WV** continuing to fill reservoir, improper unit pressures, and inoperative **C**. If unit remains in freeze with **FS** removed replace board. \* Normal freeze cycle will last 20 ~ 40 minutes depending on model and conditions. Cycle times and pressures should follow performance data provided in Tech –Specs.

**Note:** *At this time, you have checked everything but the Pump Out Cycle. You will have to repeat B) and C) to check the pump out feature after the next harvest.*

- D) Pump Out Cycle** – In this 10/20 second pump out, **C** remains energized, **HGV** energizes, **FM** de-energizes, **PM** stops for 2 seconds and starts in reverse rotation for 10/20 seconds.

This removes contaminants from the water reservoir, through check valve, down the drain and allows for power flush of **FS**. Check clear tubing at check valve housing, or unit drain, for water flow.

#### Diagnosis

**Note:** Pump out will occur depending on the setting of S4 # 5 & 6. With 5 & 6 OFF per step 2, it should occur after every harvest cycle from the 2nd harvest. If **PM** does not reverse per this setting, check **PM** circuit and capacitor. If water does not pump out, remove check valve housing and check/clean valve assembly.

- E) Normal Harvest Cycle** – This is the same as Initial Harvest Cycle. Return to B) and unit cycles through B), C), & D) until bin control is satisfied or power is switched OFF.

**Note:** Setting can be adjusted to skip D until every 3, 6, of 11 cycles and the unit always restarts at A).

#### **Legend:**

**C** – Compressor, **CC** – Contactor Coil, **FM** – Condenser Fan Motor  
**FS** – Float Switch, **HGV** – Hot Gas Valve, **LV** – Line Valve  
**PM** – Pump Motor, **RS** – Remote System, **WV** – Inlet Water Valve  
**TXV** - Thermostatic Expansion Valve,

## Reservoir Flush System:

A displacement device (cap or assembly) is positioned over the top of the overflow stand pipe. This device allows sediment to be pulled from the bottom of the reservoir and flush down the drain when overflow occurs. Water should always overflow the stand pipe for a short period, towards the end of harvest to allow this flushing action. To extend this flushing action, adjust dip switches 1 & 2 for longer harvest. If overflow does not occur, you likely have restricted water flow into the unit. Check the inlet water valve screen, incoming water line size or the external filter system. The displacement device must be in position for proper operation. If not, water goes down the drain during freeze and short cycling occurs.

## Pump-Out Check Valve:

On standard KM models, A mechanical spring & seat check valve is located in the pump-out housing. If this check valve sticks open, water flows down the drain during freeze and a 5 minute freeze cycle occurs. In this case, check for a displaced seat, trash, or a weak spring. Replace the spring if it is weak. When reinstalling the check valve, the seat always faces the pump supply. An o-ring seals the housing to the reservoir.

Pump Out Check Valve Parts			
Model	Seat	Spring	O-ring
KM - 320	433468-01	322110-01	7611-G035
KM - 515/600/650/ 900/901/1301/1800 /1900/2000/2100/ 2400/2500	433705-01	322110-01	7611-G035
KM - 1340/1601	433705-01	322685-01	7611-G035

## KML/Small KMD Pump-Out:

The standard KM series has a dual winding pump motor that reverses direction during the pump-out cycle. The reverse rotation pumps sediment down the drain. The KML models have a single winding pump motor that does not reverse. Instead of a pump-out check valve and reversing pump, a drain solenoid and the pump motor are energized by a relay so that sediment is pumped out.

## KM-61/101/151 Drain Cycle:

These small KM's empty the reservoir during the pump out period by gravity. This is called "the drain cycle" on these units. The pump stops for 10 seconds and the drain valve opens to drain mineral laden water out.

## KM Control Switch:

The standard KM unit has a single control switch as shown below.



This is a double pole/double throw, 3 position switch.

1. Placing the switch in ICE will start the ice making process by closing switch contacts to terminals 1 & 2 and 4 & 5.
2. Placing the switch to OFF open's these contacts.
3. Placing the switch in WASH will start the pump by closing switch contacts to terminals 5 & 6. 2 & 3 will also close.

## KML/KMD/KMS Control Switches:

KML/KMD/KMS models have dual control switches.

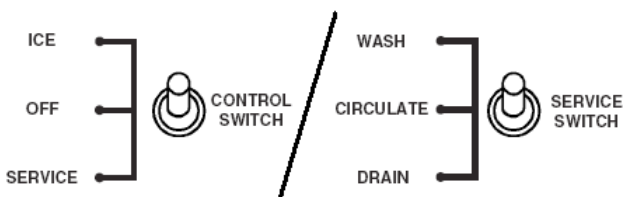

The Service Switch is not in the circuit until the Control Switch is placed in the SERVICE position.

The Control Switch is a double pole/double throw, 3 position switch.

1. Placing the switch in ICE will start the ice making process by closing switch contacts 2 & 3 and 5 & 6.
2. Placing the switch to OFF open's these contacts.
3. Placing the switch in SERVICE will close contacts 1 & 2 and energize the Service Switch and close contacts 4 & 5 to energize the pump.

The Service Switch is a single pole/single throw, 3 position switch.

1. Placing the switch to the DRAIN position will close contacts 1 & 2 to open the drain valve.
2. Placing the switch to the CIRCULATE position will open these contacts and the pump continues to run.
3. Placing the switch to the WASH position will close contacts 2 & 3 and open the water bypass valve.

## Control Board Fuse:

Beginning in May 2002, Hoshizaki introduced a 10 Amp control fuse on KM models. This feature was added to specific models as they were produced. The fuse is located in a fuse holder, which is mounted on the control box and connected in the circuit supplying 115V to the control board 10-pin connector through pins 10 & 7.

The purpose of this fuse is to protect the control board from damage in case of a short circuit in one of the components. This fuse will also offer some protection against external wiring problems, voltage spikes, and surges.

If the fuse is blown, you should isolate each individual component and check for shorts and/or grounded conditions with a good quality ohm meter. It is important that any external wiring connections, including the remote condenser circuit be checked before replacing this fuse.

If the problem is not corrected, the fuse will blow again. It is not recommended to bypass or up size the fuse as this will likely create an overheat condition and could result in a shock hazard or component damage. The defective component would likely overheat, short or fail in this case.

In the event of an accidental short or a burnt trace on a control board connection, you should check the component that connects to the pin on the back side of the board as the first step.

The fuse is a Bussman AGC 10 Amp 250VAC fast acting fuse, Hoshizaki part # **4A0893-07** and should only be replaced with one of identical size and type. A replacement fuse is taped to the control box.

Should you want to add this feature to an existing KM unit in the field, you can order fuse holder # **4A0892-01**, fuse label # **4A2817-01** and fuse # **4A0893-07**, through your local distributor. You should also make a note on the wiring diagram indicating the fuse addition, fuse size and type.

On the following page, you will find a typical wiring diagram showing where the fuse is wired in the circuit and the label that is included on the control box.



A fuse is used on all KM-H models whether a thermostat or mechanical bin control is used.

(Fuse Label)

**CONTROL FUSE (10A)**  
 If fuse blows, look for shorted component before replacing.

4A2817-01

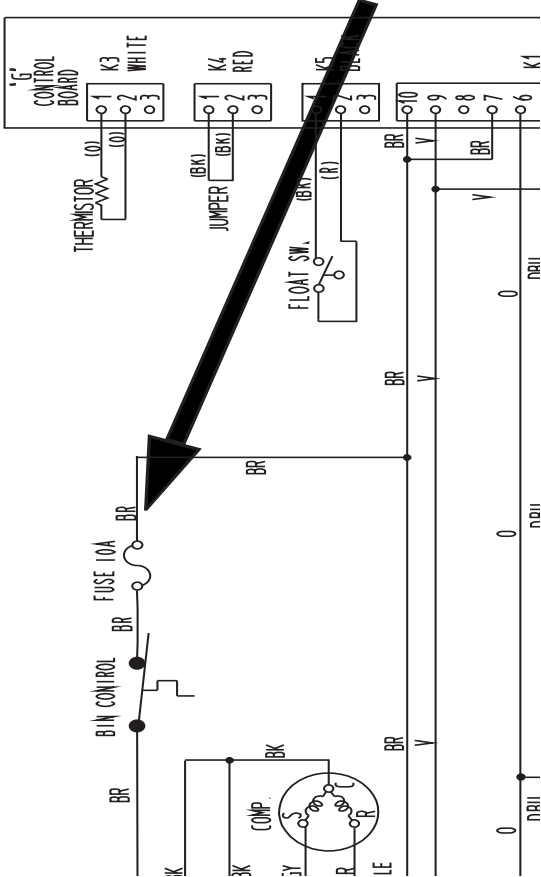

## Component Checks:

### Float Switch:

Check out the float switch with an ohm meter. When the float is up, the switch is closed. When the float is down, the switch is open.

### Sticking Float Switch

It is important to remember that the float switch is in the water circuit and is susceptible to scale buildup. This can cause the float to stick up or down. If the float switch is sticking, it should be cleaned thoroughly with ice machine cleaner and checked for proper operation. If the float switch is defective, it should be replaced. Note that a dirty float switch is not considered a warranty item.

Heavy scale can be difficult to remove from the float. The float is available as a replacement part as well as the float pin. If the housing is defective, replace the complete float switch assembly. The symptoms of a sticking float are:

**UP/CLOSED:** 60 minute freeze cycle, larger cubes, and pump cavitates prior to harvest.

After 2 consecutive maximum freeze cycles, the unit will shut down on a 3 beep safety.

**To reset this alarm, press the Alarm Reset button on the board with power ON.**

**DOWN/OPEN:** Unit shuts down on low water safety and water runs continuously.

Float Number:  
4A3624F02  
Retainer rod number:  
4A1141-01

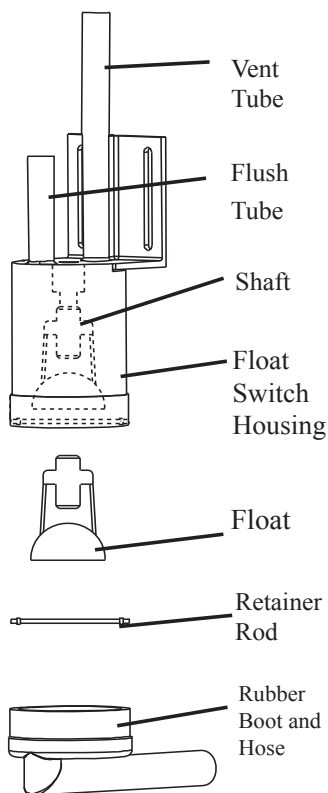

## Universal Replacement Float Switch:

There are two styles of KM float switches. One has no hole in the outside pipe and one has a hole in the outside pipe. Float switch number **4A3624-01** can be used as a universal replacement on any KM unit. Simply seal off the small hole in the outside tube with silicone or a seal cap from 3/8" refrigeration tubing if it is not needed.

This universal replacement cannot be used on some models:  
KM-61/101/151B uses float switch number 4A3624-02.  
KM-201/260B uses a unique float switch number P00816-01.  
KMD-450M uses float switch part number 4A3624-04.  
DKM-500BAH uses float switch part number 4A3624-03.

## Dual Float Switch

Some newer models use a dual float switch to operate the refill water valve. This is necessary because of the size of the reservoir on some designs. The switches can be checked with an ohm meter using the black lead as common and check either the red or blue circuit. When the float is raised up, the switch should be closed.

This is the same float switch used of F/DCM models.

KM-251/255 Float Switch Part # 435490-02 has 2 floats and 2 switches.

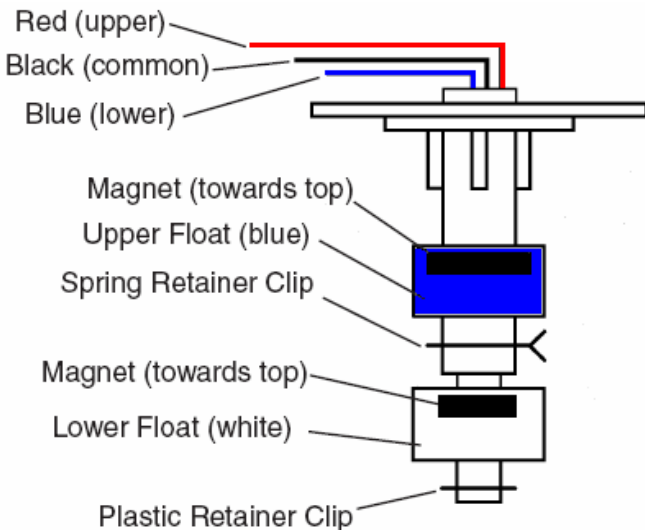

KMS Float Switch Part # 468264-01 has 1 float and 2 switches.

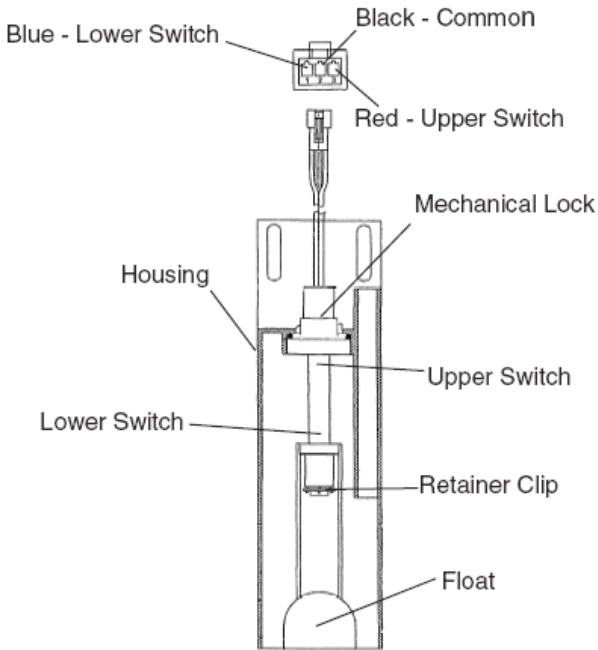

### Connector Boot

The float switch boot will sometimes collect scale deposits since it is in a low area of the water circuit. The boot should be cleaned thoroughly during scheduled maintenance. Due to age and high amounts of chlorine in the local water supply, it can also deteriorate and may cup upward in the middle holding the float up. In this case, the boot should be replaced. Order part number **426799-01** as universal replacement part and cut the tube to length as needed.

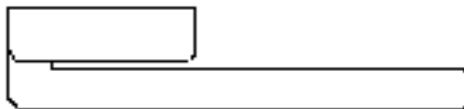

Universal float boot

# 426799-01

(Cut tube to length)

## Thermistor:

Thermistor part number 429006-03, can be used as a universal replacement for all E and G board units, except DKM-500B which uses longer part number 429006-06. H board thermistor P00027-01 has a unique connector. For all KM Thermistors, check out the thermistor mounting and check resistance versus temperature per this chart:

THERMISTOR TEMPERATURE / RESISTANCE	
SENSOR TEMP (F°)	RESISTANCE (K OHMS)
0	14.4
10	10.6
32	6.0
50	3.9
70	2.5
90	1.6

The symptoms of a bad thermistor are:

**OPEN:** 20 minute harvest cycle. The unit will shut down on a 2 beep safety after 2 consecutive 20 minute harvest cycles.

**SHORTED:** Unit locks out on manual reset high temperature 1 beep safety and will not reset in this case.

**High Temperature Safety:** If evaporator reaches 127°F the thermistor signal (500 ohms) shuts down the unit on this manual reset. A 1 beep alarm will occur. **To reset this alarm, press the Alarm Reset button on the board with power ON.** Then check the items listed on the control board label for a 1 beep alarm.

**Note:** The Thermistor must be mounted using a heat sink compound to assure good heat transfer and accurate sensing. Use Hoshizaki Part Number **4A0683-01** or equivalent (Radio Shack #276-1372 or GE Electronics #10-8108, etc.).

## Control Board (E or G Board):

The electronic control board maintains the sequence of operation. There are 3 input connections to the board.

1. The Float switch connects to the control board through the black K5 connector.
2. The thermistor connects to the control board through the white K3 connector.
3. If a mechanical bin control is used, it will connect to the K4 red connector.

The control transformer supplies 10.5 VAC control voltage to the K2 connection. The control board will not operate unless control voltage is present at K2. Proper control voltage is indicated by the Power OK red LED ON.

The final connector on the control board is the K1 10-pin connector. This connector supplies 115 VAC into the control board for switching components or relay contacts and powers the individual components during the sequence of operation.

The control board also has dip switches that allow for board adjustments. These switches are set from the factory for proper operation and maximum efficiency. See control board adjustment chart for factory settings and adjustments.

### **E or G Board Checkout:**

Before replacing a control board that does not show a visible defect and that you suspect is bad, always conduct the following checkout procedure. This procedure will help you verify your diagnosis.

1. Check the dip switch settings to assure that #3,4, 7, 8, 9, & 10 are in the factory setting. Output test switch S3 should also be OFF. Switches 1, 2, 5, & 6 are cleaning adjustments and the settings are flexible.
2. Turn the control switch to ICE and check for proper control voltage. If the Red LED is ON, the control voltage is good. If the Red LED is OFF, check the control transformer circuit. See checking control transformer.
3. Next, check the 115 volt input at the 10-pin connector. Check the brown wire at pin #10 to a white neutral wire for 115 volts. (Always choose a white neutral wire to establish a good neutral connection when checking voltages.) A jumper also feeds 115 volts into pin # 7. If no voltage is present, check the 115 volt supply circuit.
4. Check the board sequence using the S3 output test.
  - a) Turn the control switch to OFF.
  - b) Turn the Control switch to ICE. Press S3. Watch the lighting sequence of the 4 green LED's numbered 1, 4, 3, 2 from the board edge. The Red LED should light in about 5 seconds. **For E Board:**  
About 5 seconds later, LED 2 should light.  
5 seconds later, Led 2 will go out and LED 3 will light.  
5 seconds later, Led 3 will go out and LED 4 will light.

5 seconds later, Led 4 will go out and LED 1 will light.  
5 seconds later, Led 1 will go out and LED 4 will light.  
This sequence completes the output test and the unit is now in the 1 minute fill cycle.

**G Board:** LED's light in the following sequence during the S3 outpost test. 1, 4, 3, 2, back to 4.

**Note:** If the LED's light in a different sequence or the 5-second interval does not occur as explained, the control board is bad and should be replaced. If the test sequence is correct, turn the control switch OFF and switch S3 OFF. The S3 switch must remain in the OFF position during normal operation. The components will cycle during this test.

5. You have checked the board sequence and now need to check the output to each component through the K1 10-pin connector for 115 volts. Follow the wiring color code on the wiring diagram or use the generic drawing in the wiring diagram section to check each component for 115 volts through out the sequence and check from each pin to a white wire.

**Note:** Checking from pin to case ground can give a false reading in some instances. Always choose a white neutral wire to establish a good neutral connection when checking voltages.

## **Bin Control:**

Checkout for the bin control will vary depending on the model and control that is used.

- a) **Thermostatic Bin Control:** The thermostatic bulb is mounted in the ice drop area to sense the ice buildup. **To adjust the bin control**, hold ice against the bulb while the unit is operating. You will find it easier to place the control switch to the wash position to check the bin control operation. It is easy to hear the pump motor stop when the bin control opens. The unit should shut off within approximately 3 to 10 seconds when the control is adjusted properly. If this does not occur, adjust the thermostatic control by turning the screwdriver slot. Adjusting towards warmer will allow the unit to shut down quicker. This adjustment should be checked at installation, when diagnosing a bin control problem, or if a replacement bin control is installed.

KM's from the KM-280~901M and KML units have a bin control mounted in the ice drop zone area. KM-1300M / S and larger units have a drop down bracket that must be dropped down, secured, and plugged in at installation. **The ice must contact the bulb to operate the bin control.** Some bin applications require an optional extension bracket or relocation of the bulb mounting to allow for proper shut down. Check this positioning if the control is adjusted properly and ice continues to back up into the evaporator section. Assure that the extension bracket is installed.

**The symptoms of a bad thermostatic control are:**

**STUCK CLOSED:** The unit continues to operate when the bin is full. This allows ice to back up in the evaporator compartment and generally causes a freeze up condition. This will also occur if the bin control is adjusted too cold or fully "CW". Check the adjustment and bulb location before you diagnose a stuck bin control.

**STUCK OPEN:** The unit will not start in the ice position. An easy method to check for an open bin control is to flip the control switch to WASH. If the pump starts, the bin control is closed.

- b) Mechanical Bin Control:** The mechanical bin control uses a moving actuator paddle to open and close a magnetic proximity switch. The control is connected to the red K5 connector on the control board. For E boards it connects through a resistor harness. On G boards it connects through a wiring harness without resistors. As the proximity switch opens or closes, the switch will open and close, or the resistance will change to signal the control board to start up or shut down. The control board will only respond to this change during the first 5 minutes of each freeze cycle.

There are different styles of mechanical bin controls on various models in the field however they all work basically the same.

- a. When Ice fills the bin and pushes the actuator paddle in or towards the magnetic switch, the switch will open and shut the unit down.
- b. When the ice falls away from the actuator, the switch closes and the unit starts.

**Note: On the E board,** dip switch # 7 must be in the ON position for this control. When dip switch # 7 is ON,



push the control paddle to the full right position and the unit should shut down within 5 seconds for the E board or 15 seconds for the G board.

The following 2 safeties will occur if the mechanical control fails:  
4 Beeps = Short circuit on K5 bin control circuit.  
5 Beeps = Open circuit on K5 bin control circuit.

***To reset either safety, press the white reset button on the control board with the power ON.***

**Checkout:** To check this control with the unit running, you must be in the first 5 minutes of the freeze cycle. Turn the control switch to OFF and back to ICE. Allow the unit to cycle through the 1 minute fill cycle and initial harvest cycle. When LED 1 is on, you will know that the freeze cycle has begun, push the control paddle to the full right position and the unit should shut down within 5 seconds on the E board or 15 seconds for the G board. Another method to check this control is to unplug the wiring harness from the K5 Red connector.

For E board units, check the resistance at the end of the harness with an ohm meter as the proximity switch opens and closes.

- 1) When the control paddle is hanging in the normal position (Bin Empty), the resistance at the red K4 connector will be 7.9 K ohms.
- 2) When the control paddle is held to the full right position (Bin Full), the resistance at the red K4 connector will be 15.8 K ohms.

**Note:** Remember that dip switch # 7 must be ON and the control will have 4 and 5 beep safeties.

### **Mechanical control on G or H board**

It is important to note that dip switch # 7 does not control the red connector on the G or H board. It has a different function and should remain in the factory position.

The G board has LEDs which indicate Bin Control Open (Yellow LED) and Bin Control Closed (Green LED). These LEDs can be used as a visual check for proper bin control operation on a G board unit.

To electrically check a mechanical control on a G board or H board, unplug the connector and use an ohm meter on the control.

- a) Push the actuator/paddle to the bin full position and the switch should be open.
- b) Allow the actuator to hang in the normal position and the switch should be closed.

## KM Control Transformer:

The KM control transformer supplies 10.5 VAC to the control board through the K2 connector. This 115V/10.5V stepdown transformer is a heavy duty component with an internal thermal overload. The primary winding of this transformer will handle higher voltage without damage because the thermal overload will open to protect the winding in the case of improper supply voltage. The control board monitors the output voltage of this control transformer and provides automatic reset high and low voltage protection.

The Power OK LED on the control board will not light if no control voltage is supplied. The 115V transformer primary circuit is supplied through the thermostatic bin control, control switch, high pressure switch, and low pressure switch (if included). If either of these switches are open, there is no control voltage at the transformer connector and the unit will not operate.

On some models, the transformer secondary circuit includes an interlock switch at the cleaning valve. If this switch is open, no control voltage is supplied to the K2 connector so the unit will not operate. Always check the cleaning valve position and interlock switch if the Power OK LED is off.

**Note:** Because of the voltage protection, if the control transformer fails, it is important to use the correct OEM part as a replacement to provide proper control voltage.

## KML & Small KMD Pump Assemblies:

KML units use a vertical shaft, single winding pump assembly. The original assembly did NOT include a capacitor. The most recent pump and service replacement does. The assembly is NOT rebuildable and includes the mounting bracket as shown:

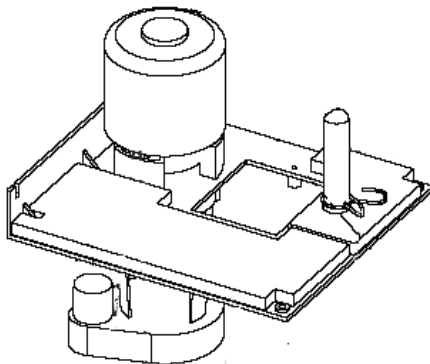

## KM Pump Motor Assembly:

The standard KM pump assembly has a dual winding PSC motor with an internal overload. The motor has a cast housing and sealed stainless steel roller bearings. No lubrication is required for these roller bearings.

All front end parts are available and can be replaced. A cracked housing, broken impeller or leaking mechanical seal are the most common failure items and can be replaced.

A hot pump motor will likely shut down on the internal thermal overload. This can occur if the pump motor runs slow or overheats. In this case, allow the pump motor to cool and check the pump motor capacitor. If the capacitor is good, it is potentially scale, a bad motor or tight bearings.

Always replace the pump motor capacitor if the pump motor fails. See the wiring diagram reference chart for the pump motor capacitor rating. If other failures occur, the front end of the pump assembly is rebuildable. If the motor fails, it is easier to replace the entire assembly.

Following, are the assembly diagram's for two generic pump assemblies. Use these drawings as a guide to reassemble a pump assembly that you are rebuilding.

## Pump Motor Assembly Diagram:

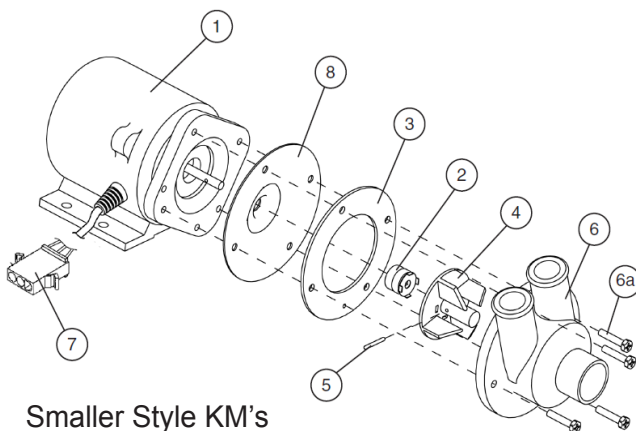

Smaller Style KM's

1	Motor	4	Impeller	7	Connector
2	Mechanical Seal	5	Pin	8	Plate
3	Pump Gasket	6	Housing		

## Larger Style KM's

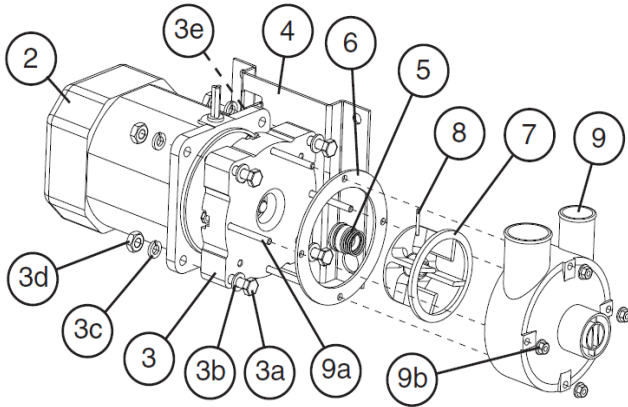

Pump Motor Assembly

2	Motor	5	Mechanical Seal	8	Pin
3	Flange	6	Packing	9	Housing
4	Bracket	7	Impeller		

### Refrigeration Solenoid Valves:

Hot gas valves, liquid line valves, isolation valves etc. are all similar in size, shape and operation. There are however different part numbers for these valves because they are ported differently. It is important to order the correct valve for replacement. Be sure to verify the correct part numbers when ordering replacement valves.

All Hoshizaki KM model refrigeration valves use a 115 volt coil. A good coil will have a magnetic pull when energized. You should be able to hear the valve snap open when voltage is applied. You should also feel the magnetic pull with a small screwdriver. Assure proper voltage and check for resistance in the 260~320 ohm range and replace if the coil is open.

You will also note that there is a bullet style screen in front of the hot gas valves. This screen protects the valve port from debris and should be replaced any time a hot gas valve is replaced. This screen must be ordered separately when the valve body is ordered.

Always take care to protect the valve body and screen from excessive heat from the torch when replacing it.

## Inlet Water Valve:

Hoshizaki uses an inlet water valve solenoid to fill the reservoir for ice making. This constant duty solenoid valve is very reliable however, in areas of hard water and high levels of chlorine, the diaphragm is susceptible to failure. Water quality is constantly changing and local municipalities are now adding higher levels of chlorine, chloramine, and chlorine dioxides to the water. These agents can damage rubber parts and affect the diaphragm life. Newer valve diaphragms use an improved viton material to reduce deterioration.

The diaphragm is made of rubber and ABS, with a bleed port on the inside ABS piece. This port allows the pressure to balance on the top and bottom of the diaphragm so that the valve will open and close properly with the spring pressure. If the rubber becomes dry and brittle or the bleed port is plugged with trash or debris, the valve will leak by. In this case, some valves can be disassembled for cleaning and the diaphragm and inlet screen can be cleaned or replaced. It is important to remember that the warranty covers repair of defects and not cleaning. Should the valve be scaled or dirty, it should be cleaned and billed to the customer.

As noted, some water valves include a replaceable diaphragm. Below you will find an exploded view of the valve assembly and instructions for reassembly of the valve. When replacing the diaphragm and re-assembling the valve, it is important that the plunger is in the correct position. This plunger has a white plastic seal on one end and is metal on the other. The white seal end of the plunger **must** be in contact with the diaphragm in order for the valve to work correctly.

CKD Valve Breakdown

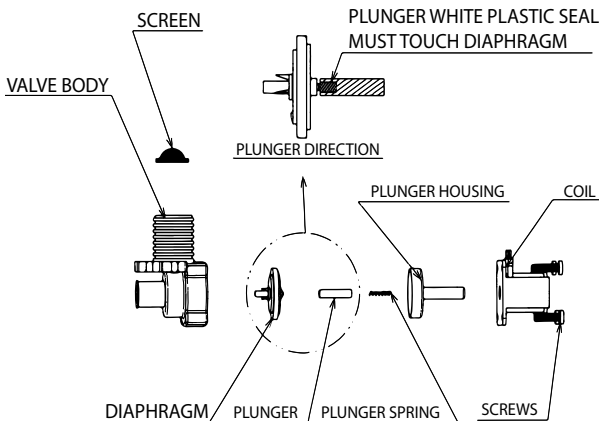

**Note:** Because of the different flow rates, it is important to use the correct OEM water valve when servicing a Hoshizaki ice maker. Use the following chart to identify the correct valve, diaphragm, or inlet screen.

## CKD Valves

Model #'s	Valve #	Vendor #	Diaphragm
KM-251/255B	3U0152-01	J248-662	4A3362-01
KM-201/260B, KM-320M, KML-351MWH, KML-451M, DKM-500BAH	3U0150-01	J248-647	4A3362-01
DKM-500BWH, KML-250/350/351 KML450/631, KML-351MAH, KM-461/501, KM-515/901M	3U0111-04	J248-072	4A3362-01
KMD-300M/450M, KML-600M, KM-500 KMS-830M	3U0111-03	J248-033	4A3362-01
KM-600/650/900M KM-1340/1601M, KMD-850M/901M, KMS-750/822/1230 KMS-1300/1400	3U0111-02	J248-032	4A3362-01
KM-1800/2000S, KM-2400S	3U0136-01	J248-106	4A3362-01
KM-1300S/1600S	3U0111-01	J248-030	4A3362-01

### Replacement Water Valve Gasket

The replacement rubber gasket or packing {valve washer} for all valves is #413854-03. This gasket must be in place or the inlet water valve will leak.

### Replacement Water Valve Screen

Replacement screen for all CKD valves # SP9200010. This is an 80 mesh screen designed to catch debris from the water system. It should be checked during regular maintenance and replaced if damaged.

## Invensys, EATON, and Other Valves

Model #'s	Part #	Vendor #	Diaphragm #
AM-50B	458548-01	V190.8l/m	Non-replaceable
KM-61B	P00463-01	N/A	Non-replaceable
KM-101/151B	P00464-01	N/A	Non-replaceable
KMD-410M	P01559-01	N/A	Non-replaceable
KM-320M-E	4A1176-05	1261860	Non-replaceable
KM-515/650M-E	4A1176-06	1261840	Non-replaceable
KM-500M-E, KMD-700M/900M	4A1176-03	1268160	Non-replaceable
KM-630/M-E, KM-900M50	4A1176-01	126757-0	Non-replaceable
KM-1601/1800S, KM-1900/2100S, KM-2501S	4A1176-04	26144	Non-replaceable
KM-1300S-E, KM-1301S/-E	4A1176-02	126756-0	Non-replaceable
KMS-1122/1401M	4A5251-08	V19	Non-replaceable
KM-1601/1900S, KM-2100/2500S, KMH-2000S	4A5251-04	V19	Non-replaceable
KMS-2000M	4A5251-02	V19	Non-replaceable

\* Replacement screen for valves above is part number SA0019

### Water Valve Coil:

The coil or solenoid for ALL KM water valves operates on 115 volts. The coil is not replaceable on any water valves. Check the coil for proper voltage during the fill cycle.

If the valve energizes and hums but does not open or flow, check water supply, check for sticking valve or plugged screen. The most common problem with a water valve coil is an open winding. If power is supplied (orange wire) and the valve does not energize, check the coil for an open winding (infinity) with an ohm meter.

Check other components using a good quality multimeter and normal electrical diagnostic procedures.

Coil resistance will be as follows:

CKD valves: in the 1430 ohm range +/- 10%.

Invensys/ Eaton valves: in the 1147 ohm range +/- 10%.

Drain Valves: in the 4.52 M ohm range +/- 10%.

HGV Coils: in the 289 ohm range +/- 10%.

## **KMS Serenity:**

The KMS model units are designed for use with the Hoshizaki SRK remote condensers. The purpose of the KMS system is to remove the noise and heat from the unit head location providing less noise for the customer and a better ambient surrounding the ice maker head.

The KMS head is a low side system that gets control voltage via a factory supplied wiring harness connected to the SRK unit. The SRK is a “true” remote condensing unit which includes the compressor and is designed for outdoor, rooftop installation. This condensing unit is specifically for use with the KMS head and cannot be used with a standard KM remote model. Likewise, the standard URC condenser cannot be used with a KMS head.

In general, the KMS unit, like the KMD, was designed for ice on beverage dispenser application. A mechanical bin control is used to avoid temperature shut down issues. The depth of the KMS ranges from 16.5” to 24”. The 24” deep models have a removable reservoir to allow for access to the dispenser bin for cleaning and service.

The KMS series utilizes the G control board and includes the pump harvest assist features to assure that all ice is removed during harvest. It also includes dual control switches. A service switch allows for automatic draining for cleaning and sanitation.

Service shut off valves are used on the head and condenser for ease of installation and to allow for refrigerant pump down during service repairs. These are standard service valves that close when front seated. A hot gas valve and liquid line valve is located in both the head and the condensing unit. These dual valves are used for isolation and to assure proper refrigerant flow. The SRK unit also has a suction line accumulator to protect the compressor from liquid flood back during and after harvest.

A single power supply circuit is connected to the SRK condensing unit on the roof. A 6 lead, color coded wiring harness connects the SRK to the KMS head and supplies control voltage to the head.

The KMS system operation is common to the standard KM models. See the service manual for additional information on operation and diagnosis of the additional KMS components.



## KM Evaporator:

The KM product with its stainless evaporator plates has been in production since 1988. There have been minimal changes in the design however, there are three designs of stainless KM evaporator plates used in this series since production began. The additional plate designs incorporate improvements in manufacturing, durability and efficiency. Recognizing and understanding the evaporator designs and differences will aide you in diagnosing and servicing these plates. Care should be taken to assure that the proper part is used in case evaporator replacement is necessary.

1. **SD** is the initial **S**mall **D**imple plate that has been used since the KM production began. This is the standard KM design. Crescent cubes should form and release separately on this evaporator.

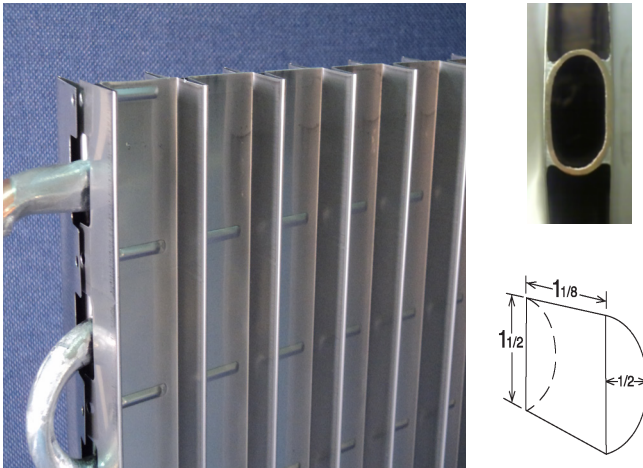

2. **LD** The **L**arge **D**imple plate used on various KM series models is very similar to the **SD** however the cube separator fins on the plate are shorter and the dimple is larger. The larger dimple aides in cube release. Also, the ice cubes form a small bridge across each row horizontally to help the cubes release during harvest. The bridge is not noticeable once the cubes harvest. The LD plates produce a standard crescent cube.

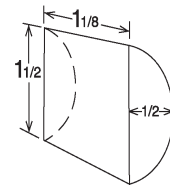

LD

3. The Tree evaporator has a different shape due to the manufacturing process and design. The cubes also bridge across the rows. The cube forms a little differently however it still maintains a similar crescent shape with a barely noticeable taper of the cube. These plates are used on the small KM models up to KM-260B and the KMS-1022MLH Model.

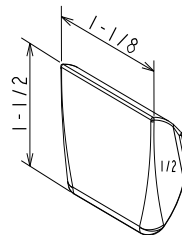
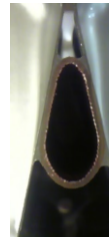
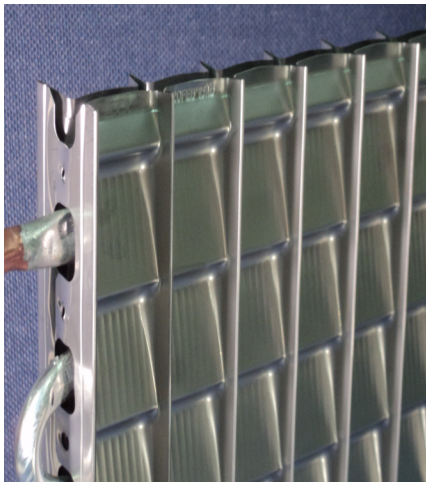

## Diagnosing Water Problems

Many common water related problems will cause cubes to look unnatural. Looking at the ice in the bin will point you towards the problem area. Study these shapes and causes to help you diagnose water related problems.

### 1. Normal cube, No problem.

Average cube size 1/2" thick x 1 1/8" wide x 1 1/2" high.

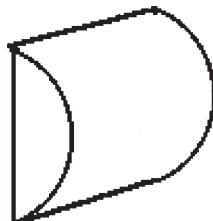

### 2. Larger than normal cube with heavy saddled edges.

**Note:** Normal cube may have slight saddled edge.

If the float switch sticks in the up position, (closed ) the unit will have a consistent 60

minute freeze cycle. This will result in heavy saddled edges and may cause pump cavitation and ice to stick on the evaporator or ice bridging (see #3).

**Note:** *If ice sticks, due to larger edges, a freeze up may occur.*

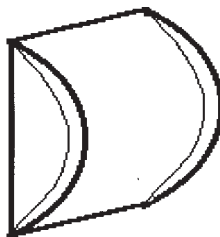

### 3. Bridging/Ice Strips

a) Bridging, that occurs on all ribs of all evaporator plates, is the result of excessive water in the reservoir.

This is caused by the inlet water valve leaking by.

Check for a plugged bleed port in the water valve diaphragm or a defective water valve.

b) May be the result of larger than normal ice cubes (see #2).

c) Bridging can occur on a few ribs if some of the holes in the water distribution tubes are plugged. An inspection of the ice build up on the evaporator will show some ribs with no ice and others with strips.

Clean the water distribution system.

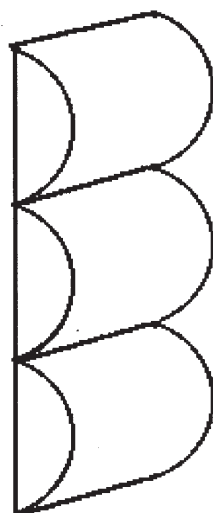

- d) Bridging on 1 or 2 plates of a multiple evaporator unit can result from water distribution problems or a refrigeration system problem. Eliminate water problems first then check TXV, hot gas valve, charge, etc.

**Note:** *Bridging will generally cause a freeze up.*

#### 4. Back of Cube Melted Away

- a) This can occur if the evaporator plate is scaled up. De-scaling is required.  
b) Insufficient water flow during harvest can also cause the flat side of the cube to melt away. Check for a plugged inlet water valve screen, plugged external filter, low water pressure, or a small water line size.

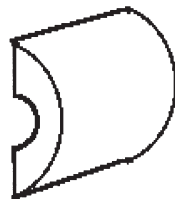

**Note:** *Either, or both, of these problems can cause this symptom.*

#### 5. Small Cube

**Note:** *Size will depend on how much water is in the reservoir.*

- a) Can be caused by a low volume of water at the beginning of freeze. Check for adequate water flow during harvest. See item 4b)  
b) If the pump out check valve is stuck open or has a weak spring, the water left in the reservoir will be pumped out during the first five minutes of freeze. This results in a short cycle and slivers of ice or small cubes.  
c) Any loss of water, whether by leak, water trail, or loose stand pipe can cause this problem.



**Note:** Freeze ups can be caused by #2, #3, or #4 in any combination. Below are the 3 most common causes.

1. The number one cause however, is a dirty (scaled up) water system or evaporator. Scales reduces water flow through the water distribution system, impedes heat transfer and will not allow cubes to harvest from the plates. A thorough cleaning will eliminate most freeze ups. Hard to remove scale will require extra effort and a stronger cleaning solution.

2. The second most common reason for freeze up is low water flow. Always check the evaporator, and water flow first, then go to other checks when diagnosing freeze ups.

3. The third most common cause for freeze ups is a bin control that will not shut the unit off when the bin is full.

# Freeze Up Check List

*Complete When Diagnosing A Freeze-Up, Refrigerant Leak, Or Low Charge.*

MODEL# \_\_\_\_\_ SERIAL# \_\_\_\_\_

INSL DATE \_\_\_\_\_ FAIL DATE \_\_\_\_\_

Single / Stacked

- |   |               |     |
|---|---------------|-----|
| 1. Single unit or stacked equipment?  | [ ]           | [ ] |
|   | <b>YES NO</b> |     |
| 2. Condition of float switch - Dirty float?   | [ ]           | [ ] |
| Are contacts opening when float is down??   | [ ]           | [ ] |
| 3. Confirm... Is water pump always running during freeze cycle?   | [ ]           | [ ] |
| 4. Is thermistor properly mounted?  | [ ]           | [ ] |
| 5. Is the TXV bulb tight and insulated?   | [ ]           | [ ] |
| 6. Is water flow adequate to fill sump to overflow last 60~90 seconds of a normal harvest?                              | [ ]           | [ ] |
| 7. Is the water line sized properly? Small units up to KM-900 3/8", Large units 1/2"? If not _____"                     | [ ]           | [ ] |
| 8. Do some ice cubes remain on evaporator plates when next freeze cycle starts?   | [ ]           | [ ] |
| 9. For stacked or side by side units...are separate water lines supplied?   | [ ]           | [ ] |
| 10. When evaporator plates are dry, do you see scale?<br>Scale color: _____<br>Date evaporators were last cleaned _____ | [ ]           | [ ] |
| 11. Will thermostatic bin control cycle unit OFF within 6 seconds when in contact with ice?                             | [ ]           | [ ] |
| 12. Have you checked the bin control to assure the capillary is not touching a hot or cold source?                      | [ ]           | [ ] |
| 13. Are the evaporator separators, blue hooks and cube guides positioned properly?                                      | [ ]           | [ ] |
| 14. Does Mechanical bin control cycle unit off in 6~15 seconds within first 5 minutes of freeze cycle?                  | [ ]           | [ ] |
| 15. Does the unit have any water filtration?<br>If so, please list the following:                                       | [ ]           | [ ] |

Filter brand: \_\_\_\_\_  
 Filter model: \_\_\_\_\_  
 Filter pressure gauge reading during fill \_\_\_\_\_ psig.  
 Date filter last replaced \_\_\_\_\_

16. Is water inlet valve screen clean? [ ] [ ]
17. Does water valve close completely when de-energized  
 i.e. does it leak by in freeze cycle [ ] [ ]
18. What is inlet water pressure? \_\_\_\_\_ psig  
 What is inlet water temperature? \_\_\_\_\_ °F
19. List the control board dip switch settings. OFF / ON  
 1 \_\_\_\_\_ 2 \_\_\_\_\_ 3 \_\_\_\_\_ 4 \_\_\_\_\_ 5 \_\_\_\_\_  
 6 \_\_\_\_\_ 7 \_\_\_\_\_ 8 \_\_\_\_\_ 9 \_\_\_\_\_ 10 \_\_\_\_\_
20. Is cube size consistent from inlet to outlet of evaporator plates? (full freeze pattern) **YES** **NO**  
 [ ] [ ]
21. Is KM cube normal shape and size? [ ] [ ]  
 If not describe: \_\_\_\_\_
22. Was any refrigerant added to the unit? [ ] [ ]  
 If so, how much? \_\_\_\_\_
23. Was the unit leak-checked? [ ] [ ]  
 Were any leaks found? [ ] [ ]  
 If so, where? (Be specific)  
 \_\_\_\_\_
24. Head pressure Freeze \_\_\_\_\_ Harvest \_\_\_\_\_
25. Suction pressure Freeze \_\_\_\_\_ Harvest \_\_\_\_\_
26. How long is Freeze cycle \_\_\_\_\_ Harvest cycle? \_\_\_\_\_
27. Ambient temperature at unit \_\_\_\_\_ ° F, at cond. \_\_\_\_\_ ° F
28. Water-cooled condenser outlet water temp. \_\_\_\_\_ °F
29. Is the hot gas valve opening? [ ] [ ]
30. List model & manufacturer of bin: \_\_\_\_\_  
 Or Dispenser: \_\_\_\_\_
31. If non-Hoshizaki bin, what modifications have been made to  
 bin control mounting? \_\_\_\_\_
32. Has stainless steel extension bracket been installed on the  
 bin control assembly? [ ] [ ]
33. **ICE DROP BATCH WEIGHT:** \_\_\_\_\_

## **Preventative Maintenance**

Preventative Maintenance is the key to long equipment life and maximum efficiency. Hoshizaki recommends performing the following maintenance steps annually. The PM frequency will depend on the local water quality and operating conditions.

### **Preventative Maintenance Steps**

1. Clean the removable air filter. Hoshizaki air-cooled units include a front accessible and cleanable air filter. This filter collects dirt, dust, and grease. It can be cleaned with warm soapy water. Hoshizaki recommends cleaning the air filter twice a month or more, depending on conditions.
2. Service the external water filter system (if equipped) and check and clean inlet water valve screen.
3. Clean and sanitize the water system and bin. A cleaning label with detailed instructions is usually located on the inside of the front panel.
4. Visually inspect the unit for loose wires, oil spots, water drips, damage etc.
5. Clean & wipe exterior with a soft cloth and neutral cleaner.

### **Stainless Steel Cleaning**

Water quality is constantly changing and local municipalities are now adding higher levels of chlorine, chloramine, and sometimes chlorine dioxides to reduce bacteria in the water. Stainless steel is a durable metal however, it can be susceptible to corrosion due to exposure to chlorine gas.

As ice forms on a cuber evaporator, chlorine outgases and settles to the lowest point in the bin. This gas sticks to wet surfaces and around the door opening of the bin to form hydrochloric acid. If this acid remains on the stainless steel, rust colored corrosion occurs. With enough exposure, the corrosion can pit and damage the stainless.

If rust colored corrosion is found, it should be cleaned thoroughly with a non-abrasive cleaner and protected with a stainless steel polish. Heavy corrosion will require some effort to remove and may require the use of a cleaning agent like "Brasso" or non-abrasive powdered cleaner like "Zud" or "Bon Ami". Care should be taken so as not to scratch the stainless during the cleaning process.

## Cleaning/Sanitizing Procedure

A maintenance label that details the step by step cleaning/sanitizing procedure is located somewhere in the unit. It is generally located on the inside front panel or under the top panel. These instructions are also provided in the Instruction Manual shipped with each unit. Follow these instructions to conduct a thorough cleaning and sanitizing of the water system. Annual cleanings are recommended. More frequent cleanings may be required in bad water areas.

### Cleaners

Hoshizaki recommends “Hoshizaki Scale Away” or a similar ice machine cleaner however, any FDA approved ice machine cleaner with a 28%~30% phosphoric acid solution is acceptable. If you carry a nickel safe cleaner it is important to note that if it contains a citric acid, it is not recommended for Hoshizaki products as citric acid is can affect tin solder. Remember that KM models have larger reservoirs and require more cleaning solution than other ice makers.

Recommended Cleaning Solution Mixture		
Model	Cleaner	Water
AM-50B, KM-61~260B	5.0 Fl oz	1.0 Gal
KML-250M,	6.0 Fl oz	1.0 Gal
KMD-410/460/530M	9.5 Fl oz	1.8 Gal
KMD-450M,	9.6 Fl oz	1.6 Gal
KML-350/351/450/451M	10.5 Fl oz	2.0 Gal
KML-600/631M, KMD-700/850/900/901M, KMS-822/830M	13.5 Fl oz	2.5 Gal
KM-320~901M	16.0 Fl oz	3.0 Gal
KMS-750/1230/1400/1401M	22.0 Fl oz	4.0 Gal
KM-1301S/1340M/1400/1601S/M, KMS-1122/2000M	27.0 Fl oz	5.0 Gal
KM-1800/1900/2000/2100 2400/2500S, KMH-2000S	38 Fl oz	7.0 Gal

**Note:** For KM's, a longer circulation time may be required if heavy scale is present. Additional cleaner may added to provide a stronger solution for KM's with heavy calcium or iron scale. Assure that all scale is thoroughly removed during from the places during the cleaning process



## Additional Cleaning

### Inlet Water Valve Screen

The inlet water valve includes an 80 mesh screen to protect the water system from debris. Always check and clear this screen during the PM cleaning procedure.

### Air filter

A removable, cleanable mesh air filter is included on self-contained air cooled units. A dirty air filter will cause high head pressure and reduce production. Clean the filter twice a month with warm soapy water to assure proper air flow.

### Other cleaning

In addition to cleaning the reservoir and water distribution system, these items should be cleaned with cleaning solution and rinse thoroughly. The float switch and boot should be cleaned. Always drain the reservoir and clean and inspect the float switch housing and float assembly. Also, clean reservoir tube along with the float boot. To assure proper operation, also disassemble and clean the pump-out check valve housing and seat and the mechanical bin control assembly if included in your model. Make sure the reservoir is thoroughly flushed prior to advancing to the sanitizing step.

## Sanitizing

The system should be sanitized using a solution of water and 5.25% sodium hypochlorite (chlorine bleach). Any commercial sanitizer recommended for ice machine application is acceptable.

Recommended Sanitizing Solution Mixture		
Model	Sanitizer	Water
AM-50B, KM-61~260B, KML-250M	0.5 Fl oz	1.0 Gal
KMD-410/460/530M	0.9 Fl oz	1.8 Gal
KML-350/351/450/451M, KMD-450M	1.0 Fl oz	2.0 Gal
KML-600/631M, KMD-700~ KMD-901M, KMS-822/830M	1.25 Fl oz	2.5 Gal
DCM-270B, KM-320M~901M	1.6 Fl oz	3.0 Gal
KMS-750/1230/1400/1401M	2.0 Fl oz	4.0 Gal
KM-1301S/1340M/1601S/M KMS-1122/2000M	2.5 Fl oz	5.0 Gal
KM-1800/1900/2000/2100/2400/ KM-2500S, KMH-2000M	3.5 Fl oz	7.0 Gal

## KM Production Check

The steps for a cuber production check are as follows:

1. Time a complete cycle from the beginning of one freeze cycle to the beginning of the next freeze cycle.
2. Catch all of the ice from this freeze cycle and weigh the total batch. (Use a dish tote, large pan or plastic trash bag to catch all the ice cubes).
3. Divide the total minutes in a 24 hour day (1440 minutes) by the complete cycle time in minutes to obtain the number of cycles per day.
4. Multiply the number of cycles per day by the cycle batch weight for the cuber production per 24 hours.

$$(1440 \cdot \text{Total Cycle Time}) \times \text{Ice Batch Weight} = \text{24 Hour Production}$$

Once you calculate the production, check the incoming water temperature and ambient condensing temperature at the cuber. Cross reference the temperatures to performance data included in this handbook to see if the calculation falls within 10% of the performance data specification.

For the most accurate production check, a normal production cycle should be checked. A production cycle will start at the beginning of the freeze cycle and go until the beginning of the next freeze cycle. (Freeze + Harvest = Production Cycle)

If the evaporator compartment has been opened for service or the unit has been cut off for a long period of time, the first freeze cycle will be longer than normal because the evaporator compartment is warm. Timing this cycle can result in an inaccurate production check.

To avoid this:

1. Start the unit and allow it to operate for 10 minutes in the freeze cycle.
2. Unplug the float switch lead from K5 and cause the unit to cycle into harvest mode.
3. Replug the float switch and start timing as soon as the next freeze begins.

**Note:** Remember that the evaporator compartment **must** be closed during the production check. Removing the front cover to check the ice buildup during a production check will allow heat into the evaporator and will affect the total cycle time and actual production.

## Cuber Water/Refrigeration Circuit Drawing Reference List

*Note: Some drawings have been combined to represent more than one model.*

<b><u>MODEL</u></b>	<b><u>DRAWING</u></b>	<b><u>PAGE</u></b>
AM-50BAE.....	A.....	100
KM-61/101BAH.....	B.....	100
KM-151BAH/BWH.....	C.....	101
KM-201BAH, KM-260BAH, KM-260BWH.....	D.....	102
KM-251 BAH, KM-255 BWH.....	E.....	103
KM-280MAH/MWH & -E, KM-320MAH/MWH & -E.....	F.....	103
KMD-410MAH/MWH.....	G.....	104
KMD-450/460/530MAH/MWH.....	H.....	105
KML-250/350/351/450/451/600MAH/MWH, KML-631MAH/MWH, DKM-500BAH/BWH.....	I.....	106
KML-600/631MRH.....	J.....	106
KM-500MAH-E, KM-461MAH/MWH KM-461/501/515/600/630/900/901MAH/MWH.....	K.....	107
KM-461/501/515/630/650/901MRH, KMD-650/700/900MRH.....	L.....	108
KMD-700/850/900/901MAH/MWH.....	M.....	109
KM-900/901MRH/3.....	N.....	110
KMD-850/901MRH.....	O.....	110
KMS-750MLH w/SRK-7H, KMS-822MLH w/SRK-10H .....	P.....	111
KMS-830MLH w/SRK-8H.....	Q.....	112
KMS-1122MLH w/SRK-12H.....	R.....	113
KMS-1230MLH w/SRK-13H, KMS-1400MLH w/SRK-14H, KMS-1401MLH&J w/SRK-14H & J(3).....	S.....	114
KM-1300/1340MAH/MWH.....	T.....	115
KM-1300/1301SAH/3/SWH/3, KM-1400SWH-M/3 KM-1600SWH/3, KM-1601SWH/3, KMH-2000SWH/3.....	U.....	116
KM-1300/1340MRH KM-1600/1601MRH/3.....	V.....	117
KM-1300/1301/1600/1601SRH/3, KMH-2000SRH/3.....	W.....	117
KM-1800/1900SAH/3/SWH/3, KM-2000SWH3, KM-2100SWH3.....	X.....	118
KMS-2000MLH w/SRK-20H.....	Y.....	119
KM-1800/1900/2000/2100/2400SRH3, KM-2500SWH3/SRH3.....	Z.....	120

## A AM-50BAE

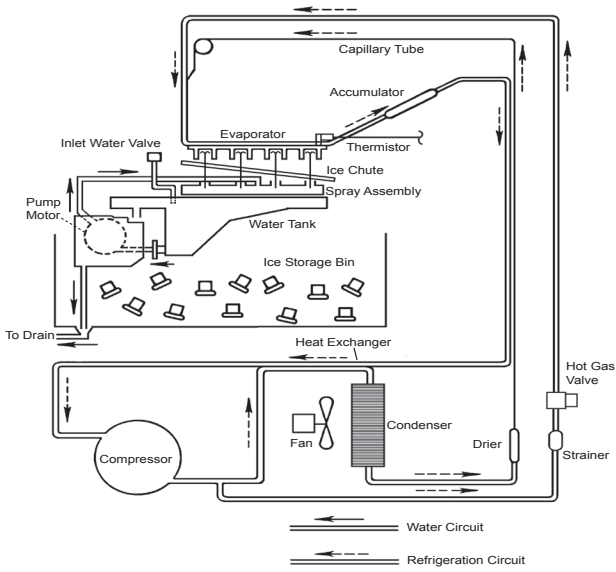

## B KM-61BAH, KM-101BAH

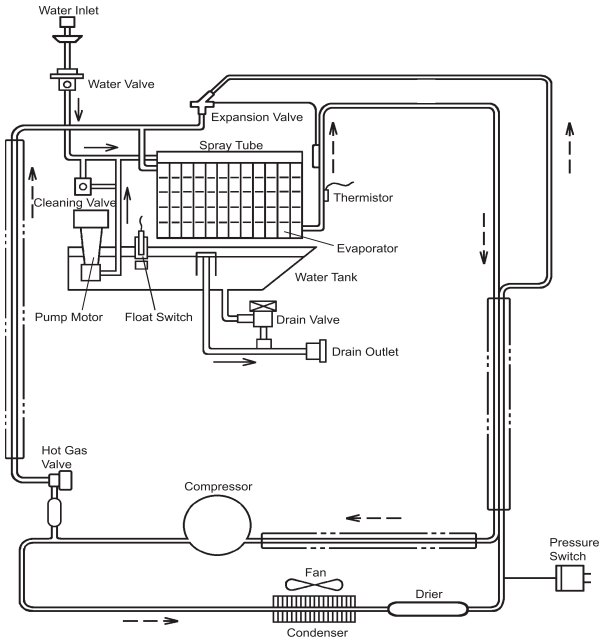

# C

## KM-151BAH/BWH

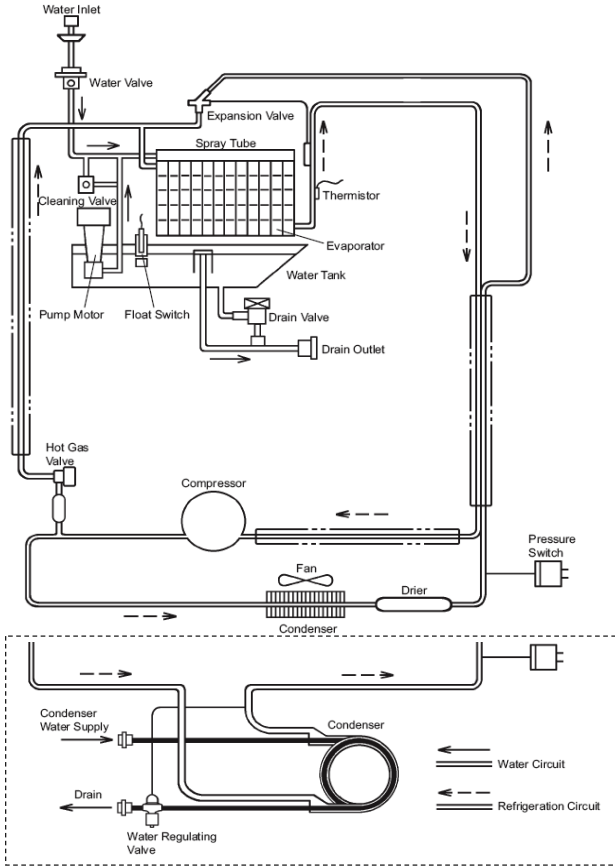

# D

## KM-201/260BAH, KM-201/260BWH

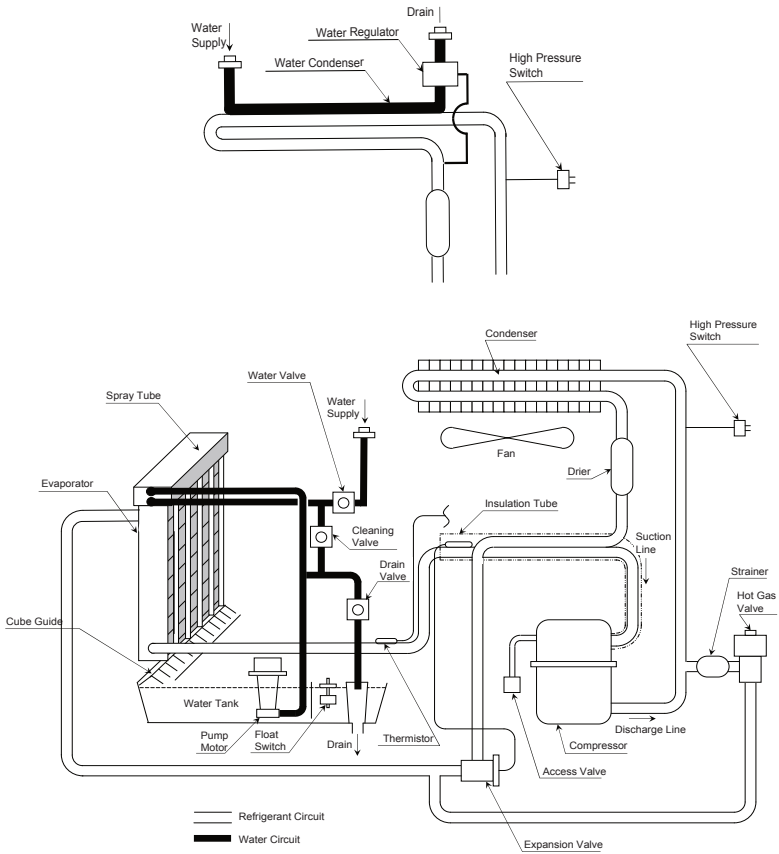

**Note:** Cleaning drain valve piping may vary slightly between models.

**E**  
**KM-251BAH, KM-255BAH**

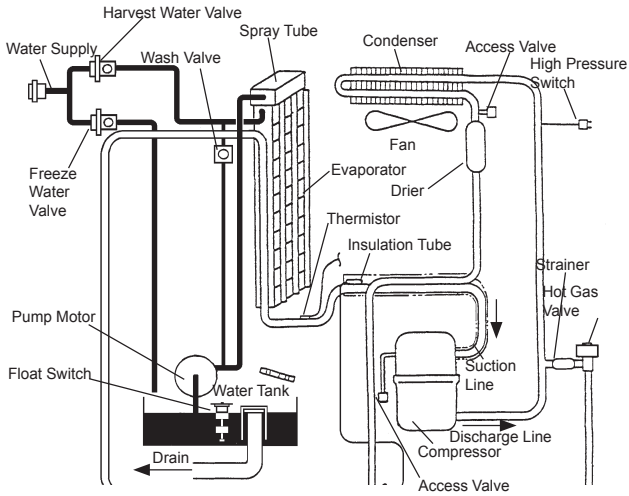

**F**  
**KM-280MAH/MWH, KM-280MAH-E/MWH/-E**  
**KM-320MAH/MWH/-E**

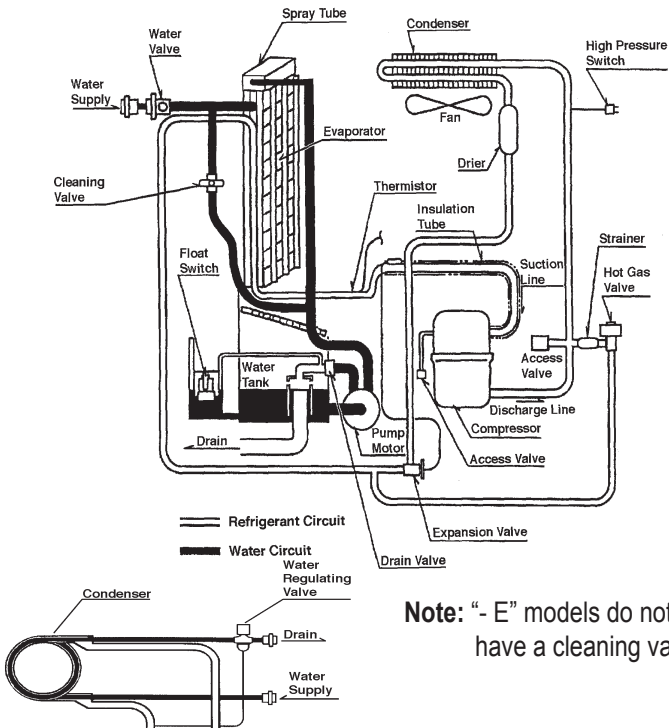

**Note:** "- E" models do not have a cleaning valve.

# G

## KMD-410MAH/MWH,

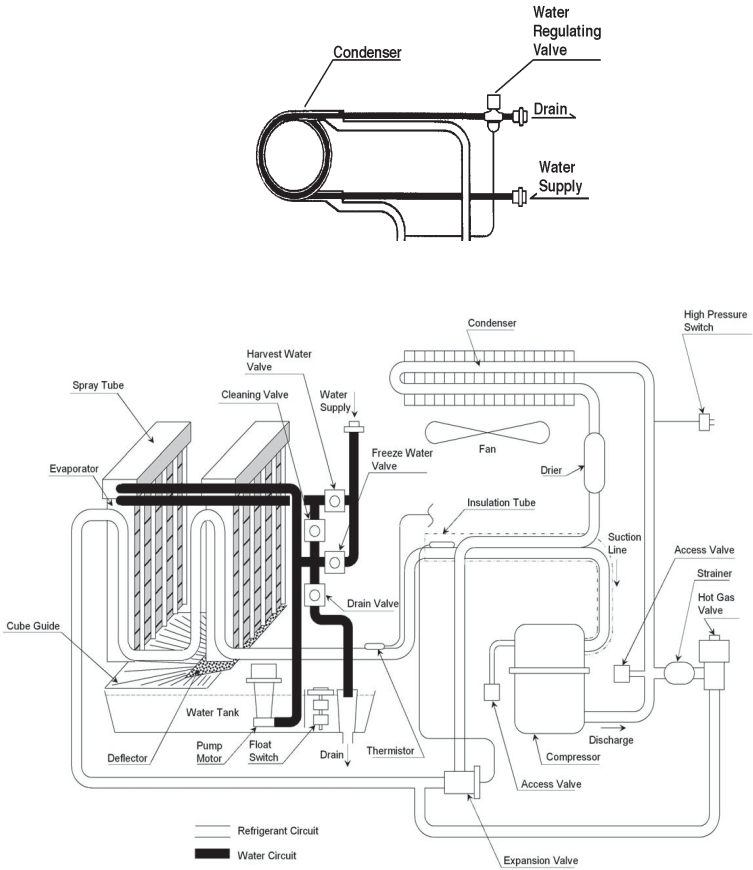



# H

## KMD-450MAH/MWH KMD-460MAH/MWH KMD-530MAH/MWH

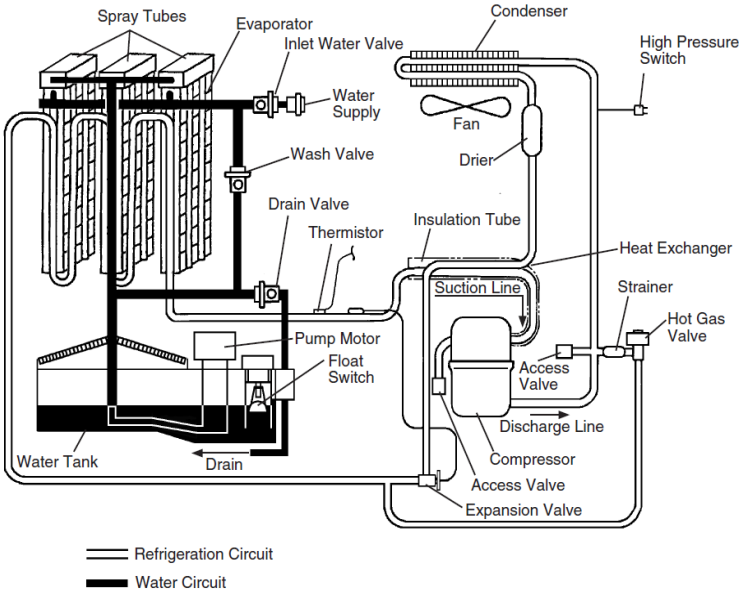
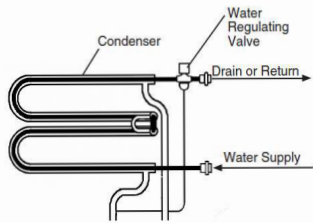

**DKM-500BAH/BWH, KML-250MAH/MWH, KML-350MAH/MWH, KML-351MAH/MWH, KML-450MAH/MWH, KML-451MAH/MWH, KML-600MAH/MWH, KML-631MAH/MWH**

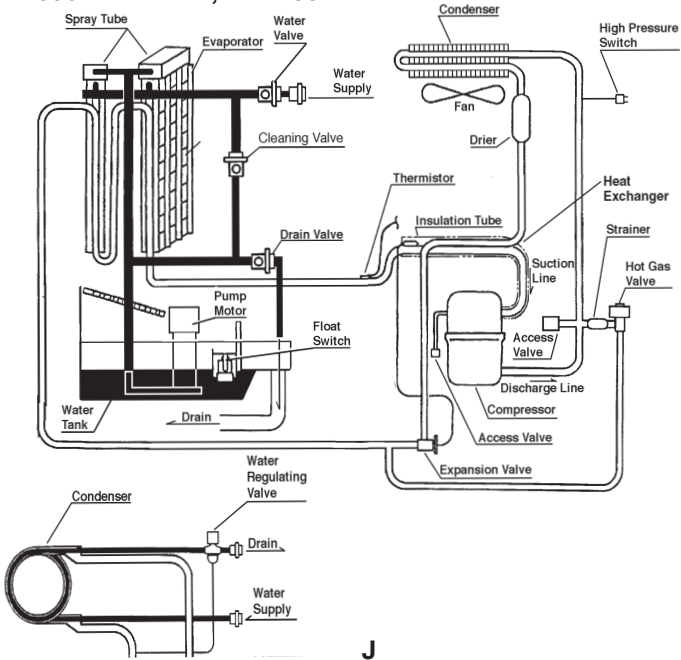

**J**  
**KML-600MRH, KML-631MRH**

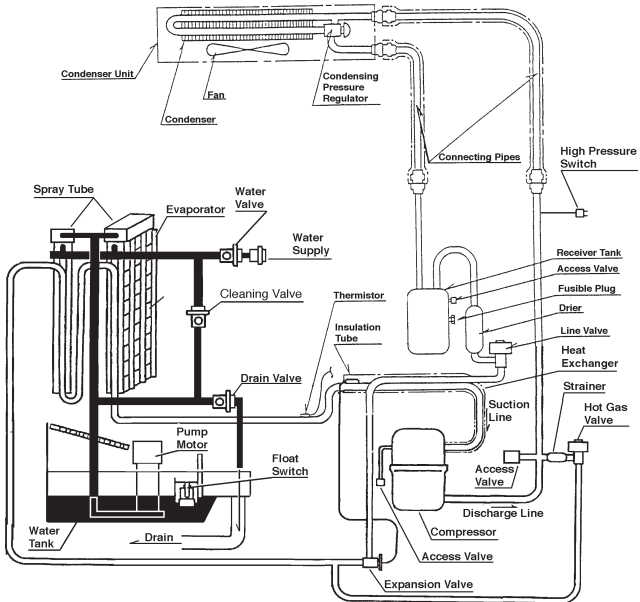

# K

**KM-461MAH/MWH, KM-501MAH/MWH, KM-501MAH-E,  
KM-515MAH/MWH, KM-515MAH-E, KM-600MAH/MWH,  
KM-630MAH/MWH, KM-630MAH-E, KM-650MAH/MWH,  
KM-650MAH-E, KM-900MAH/MWH, KM-900MAH50,  
KM-901MAH/MWH**

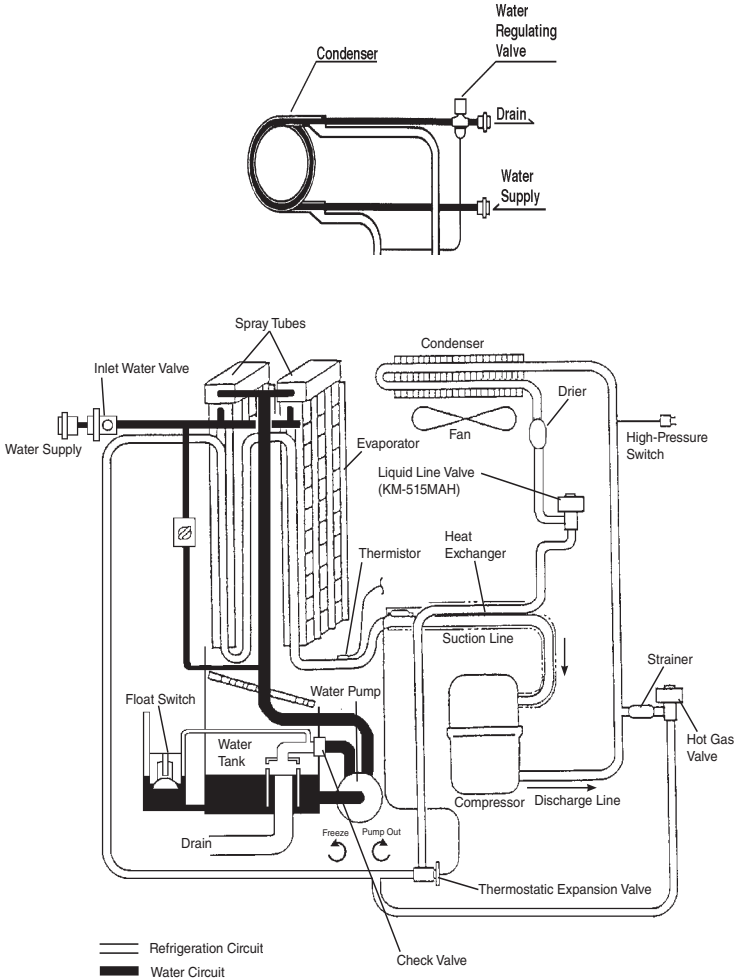

**Note:** KM-901 MAH/MWH has 2 expansion valves and check valves at hot gas valve outlet.

L

**KM-461MRH, KM-501MRH, KM-515MRH, KM-630MRH,  
KM-650MRH, KMD-650MRH, KMD-700MRH,  
KMD-900MRH, KM-901MRH, KMD-900MRH**

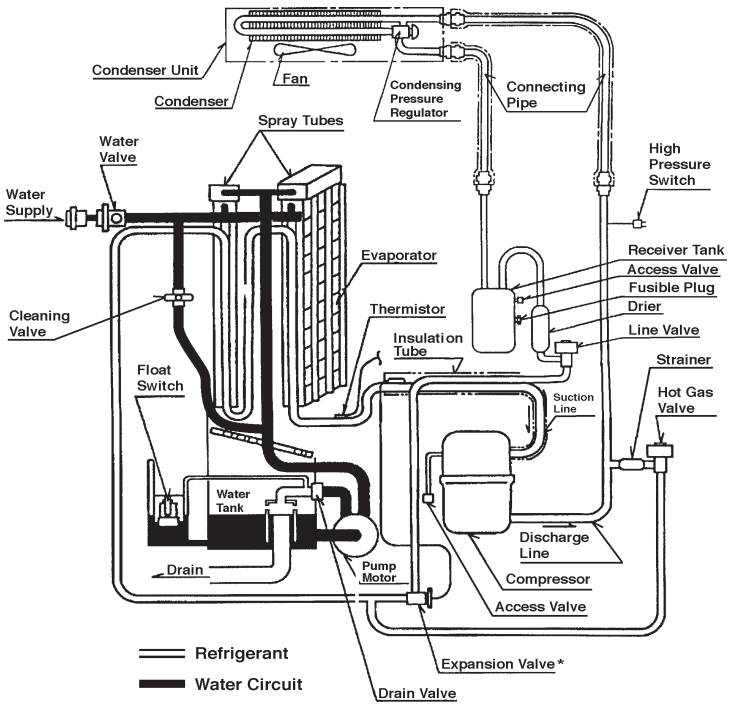

**Note:** KM-901 MRH has 2 expansion valve.

**M**  
**KMD-700MAH/MWH, KMD-850MAH/MWH,  
 KMD-900MAH/MWH, KMD-901MAH/MWH**

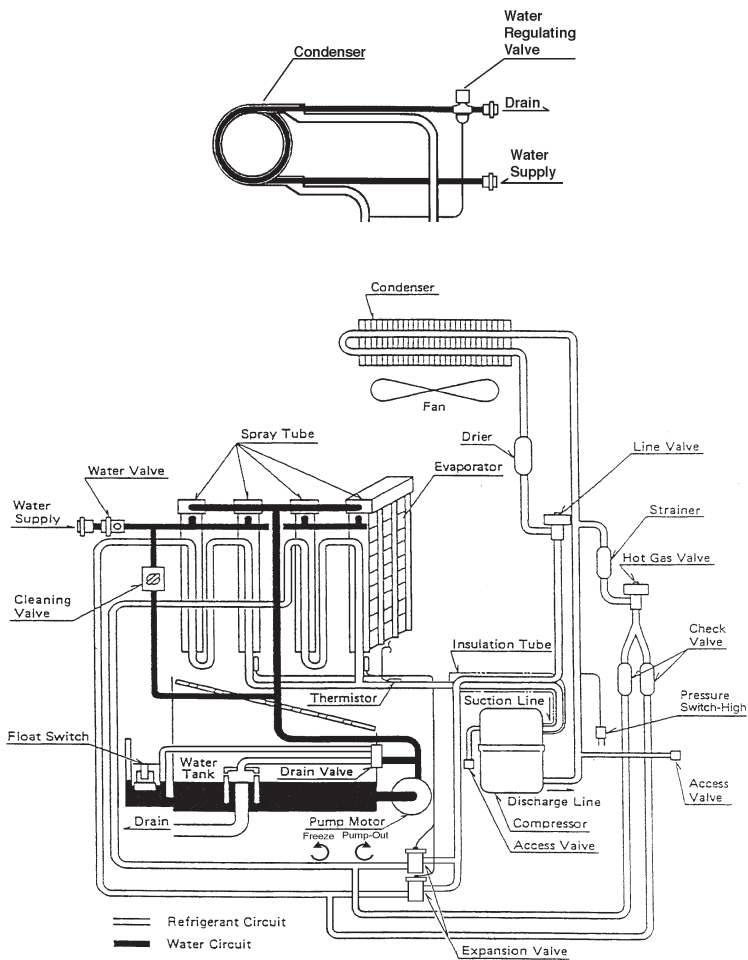

**Note:** KMD-700 MAH/MWH has 1 expansion valve.

**N**  
**KM-900MRH/3, KM-901MRH/3**  
 Condenser

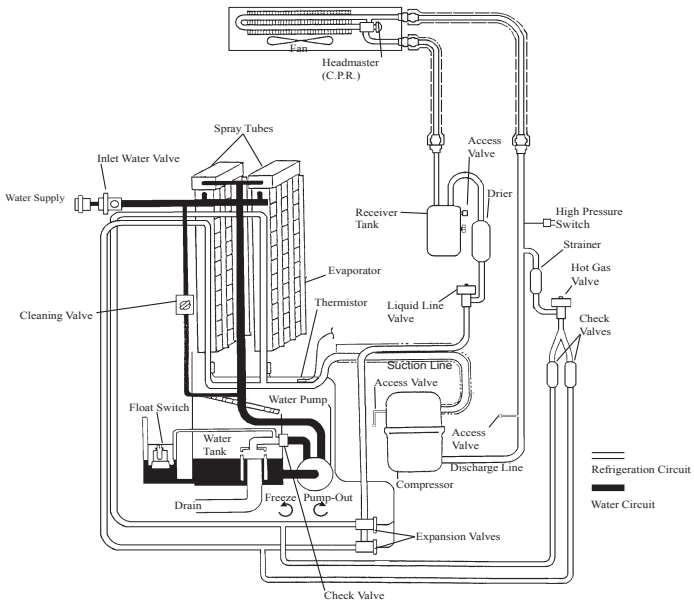

**Note:** KM-900MRH/3 has 1 expansion valve.

**O**  
**KMD-850MRH, KMD-901MRH**

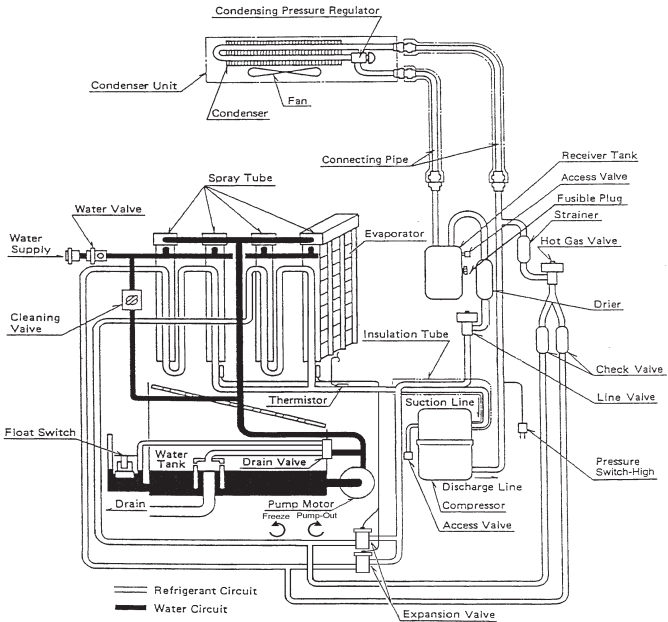

**P**  
**KMS-750MLH w/SRK7H**  
**KMS-822MLH w/SRK-10H,**

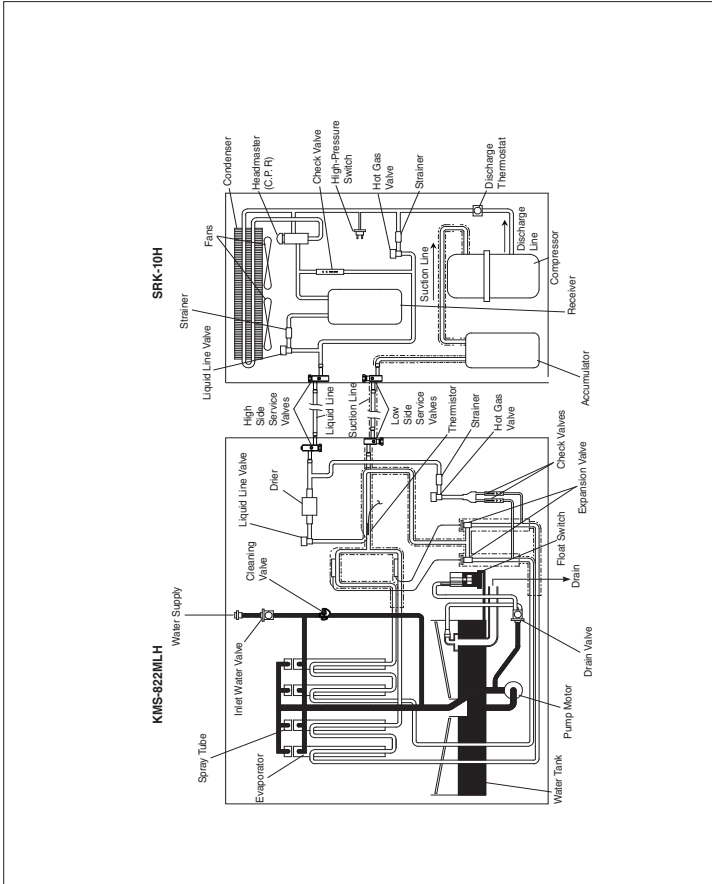

Q

# KMS-830MLH w/SRK8H

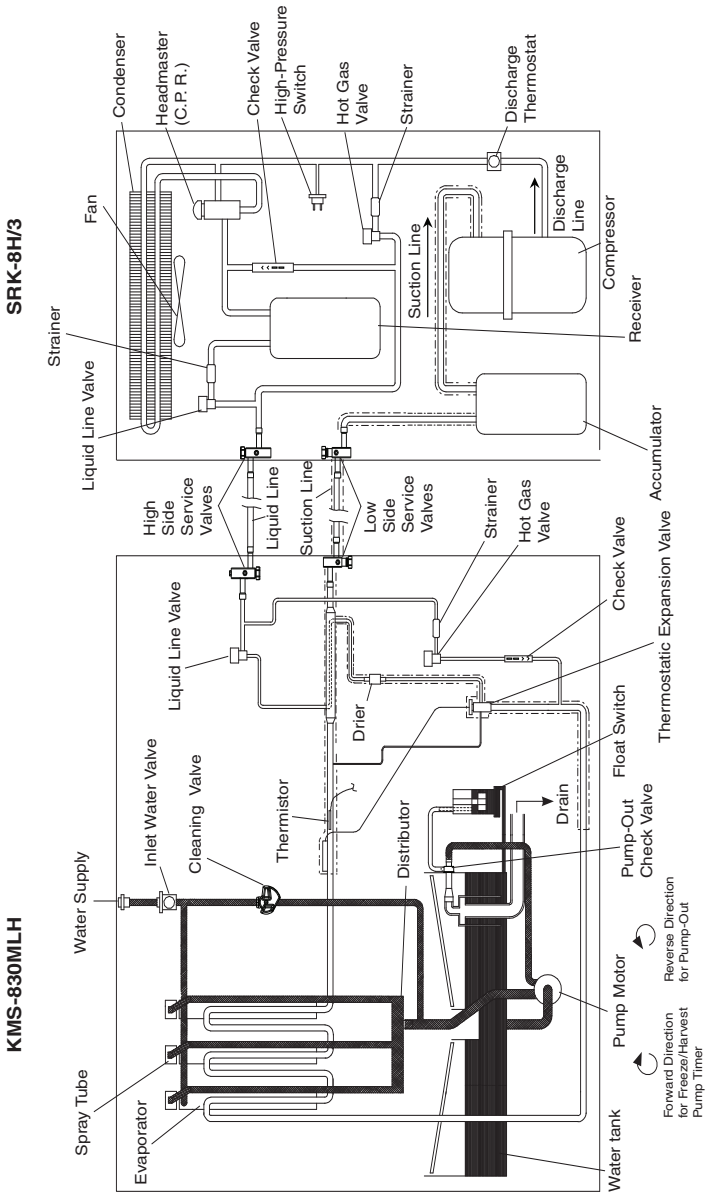



# R

## KMS-112MLH w/SRK12H

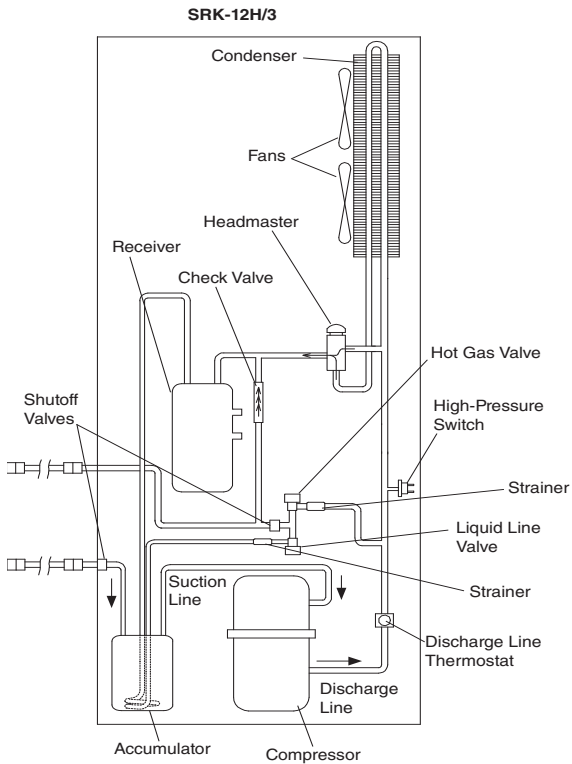
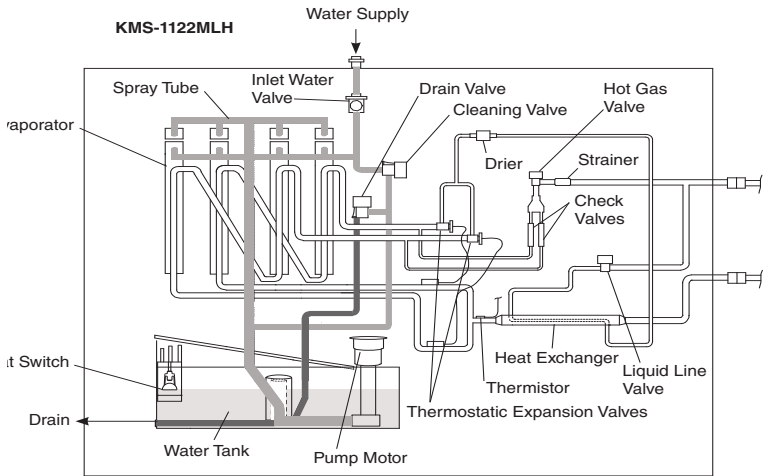

**S**  
**KMS-1230MLH w/SRK13H**  
**KMS-1400MLH w/SRK14H**  
**KMS-1401MLH & J w/SRK14H & J(3)**

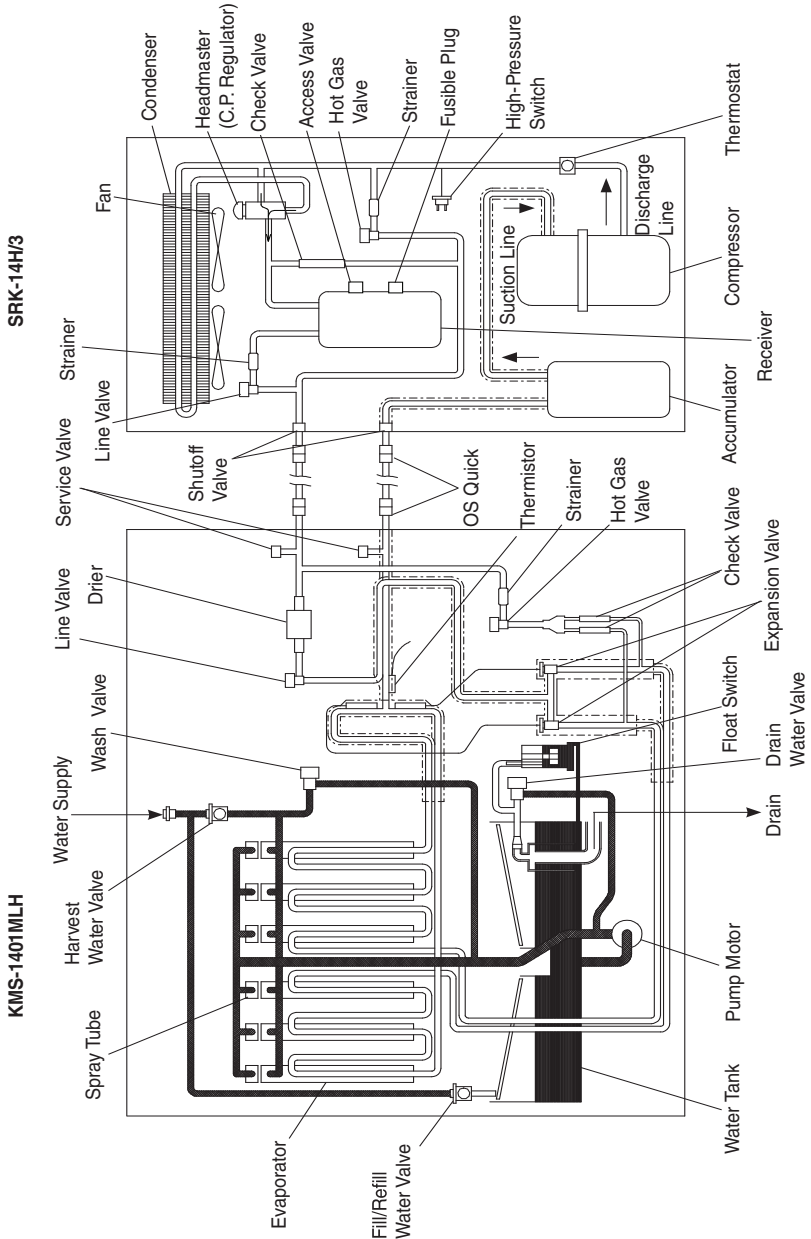

# T

## KM-1300MAH/MWH, KM-1340MAH/MWH

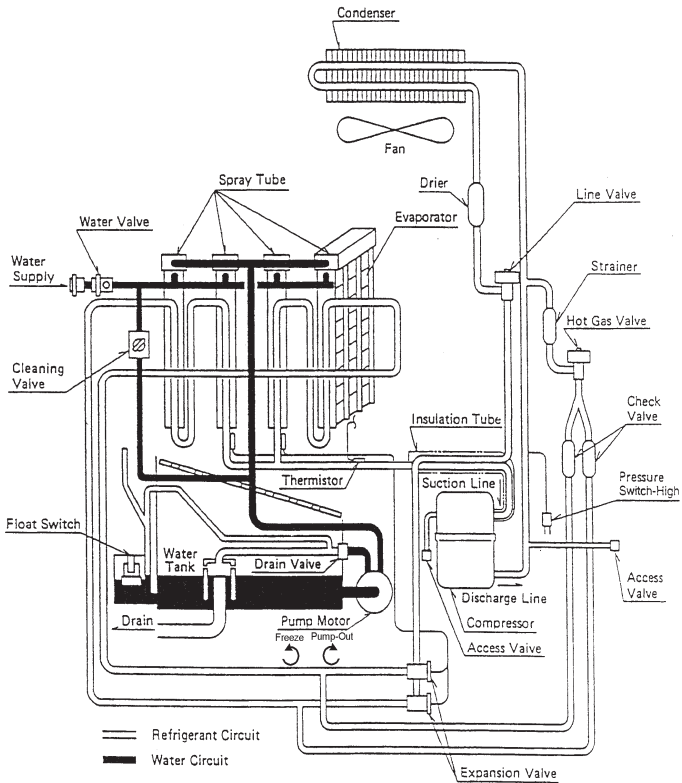
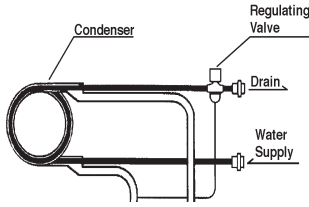

**U**  
**KM-1300SAH/3,SWH/3**  
**KM-1301SAH/3, SAH-E, SWH/3**  
**KM-1400SWH-M/3, KM-1600SAWH/3,**  
**KM-1601SAH/3, SWH/3, KMH-2000SWH/3**

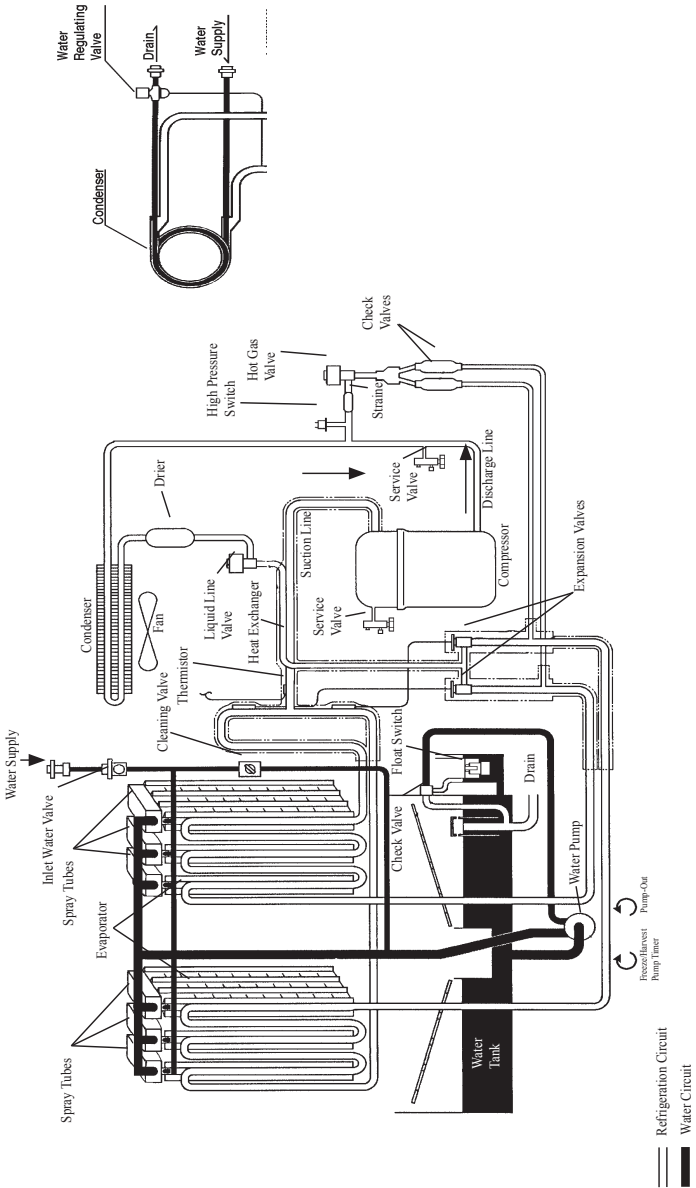

V

**KM-1300MRH, KM-1340MRH  
KM-1600MRH/3, KM-1601MRH/3**

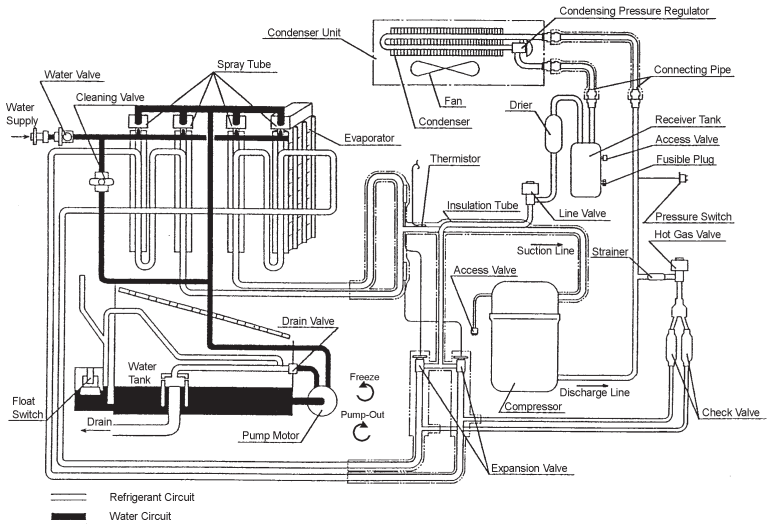

W

**KM-1300SRH/3, KM-1301SRH/3,  
KM-1600SRH/3, KM-1601SRH/3, KMH-2000SRH/3**

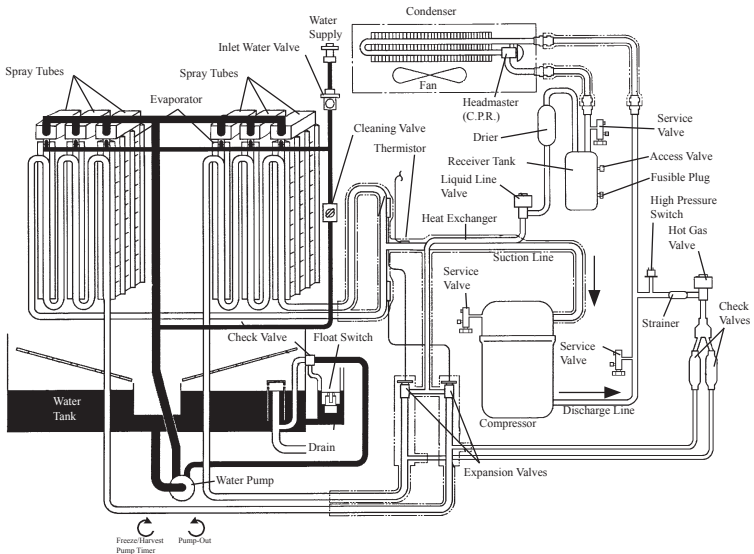

**X**  
**KM-1800SAH/3, SWH/3**  
**KM-1900SAH/3, SWH/3**  
**KM-2000SWH3, KM-2100SWH3**

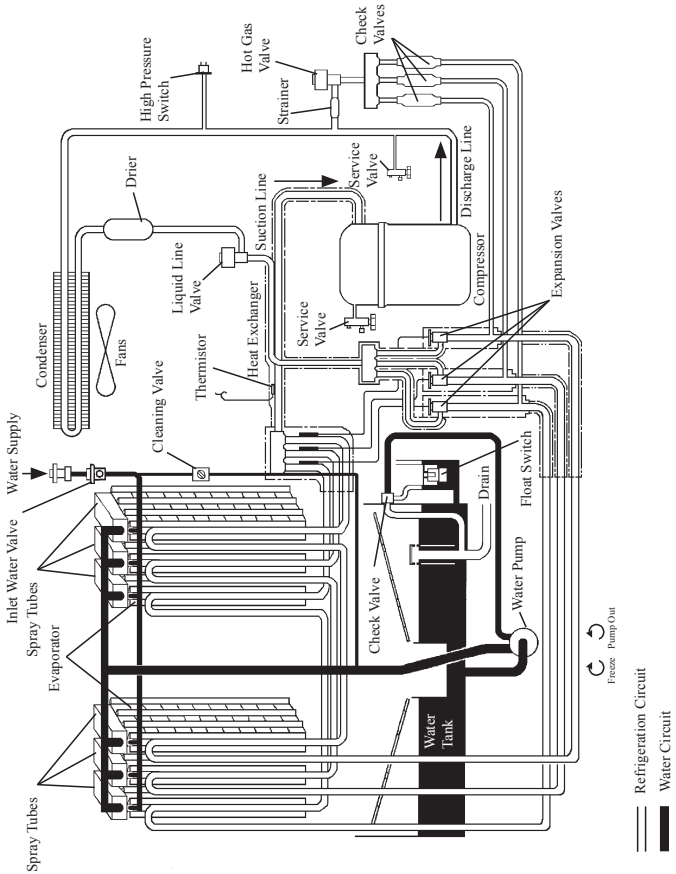
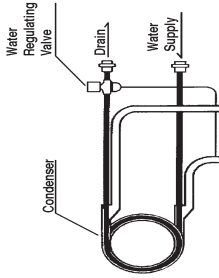

# Y

## KMS-2000MLH w/SRK-20H

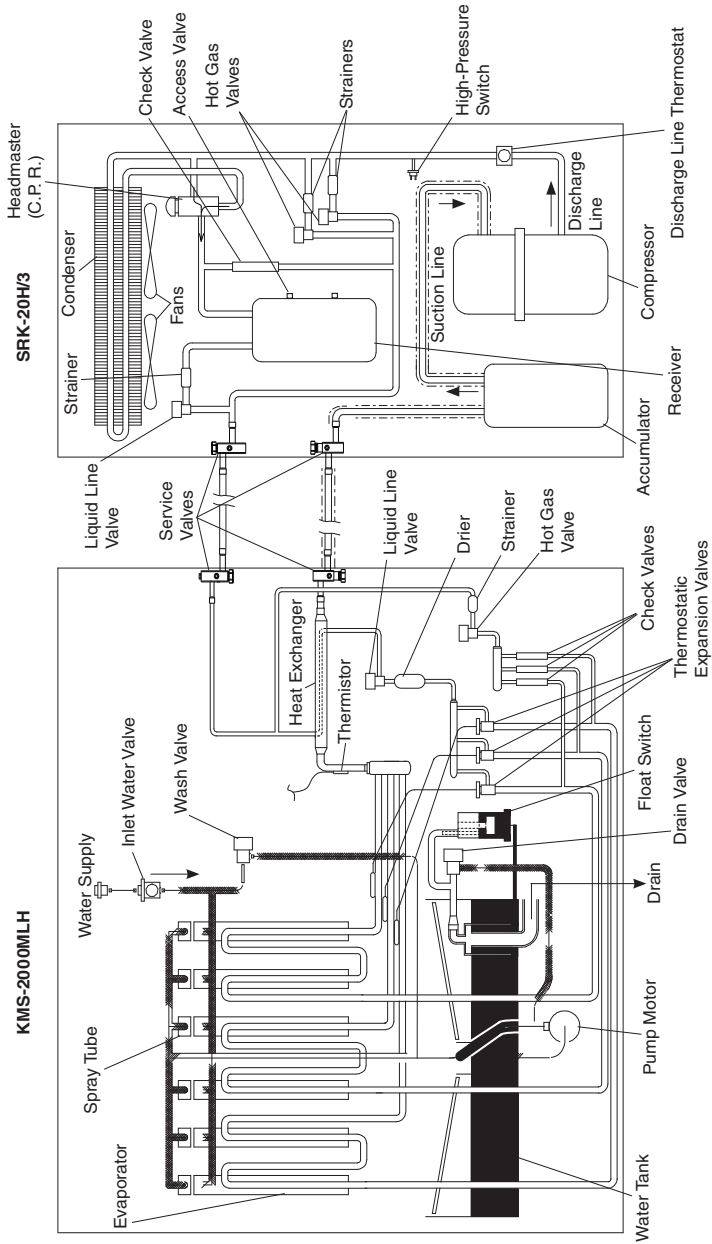

# Z

## KM-1800SRH3, KM-1900SRH3 KM-2000SRH3, KM-2100SRH3 KM-2400SRH3, KM-2500SRH3/SWH3

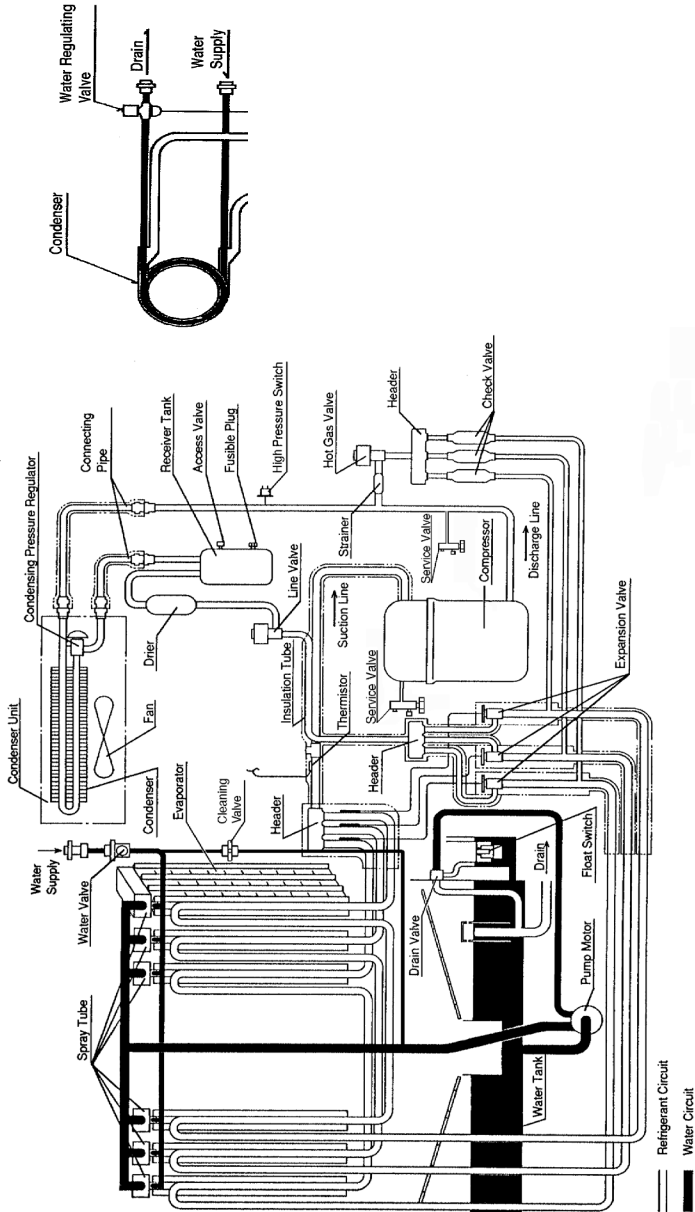



**PERFORMANCE DATA**

MODEL: AM-50BAE

Supply Voltage: 115/60/1      \*\* Refrigerant: R134A

Total Amperage (Compressor RLA):      Air: 3.4A (2.29A)

Ice Production per cycle: 0.65 lbs, 24      pcs

Ambient Temp (F°/C°)	70 / 21	80 / 27	90 / 32	100 / 38
Water Temp F°/C°	Air	Air	Air	Air
<b>Kg=lbs x.454 Production 24 hours (lbs)</b>	55 49 46	50 41 41	49 34 33	42 34 32
<b>Cycle Time Freeze</b>	15 27 20	16 19 23	17 21 25	20 22 29
<b>Cycle Time Harvest</b>	2.5 2.5 2.5	2.5 2.0 2.0	2.0 2.0 2.0	2.0 2.0 2.0
<b>Pressure High Side</b>	145 161 182	157 182 202	161 200 221	165 205 240
<b>Pressure Suction</b>	18 22 25	21 26 28	22 30 33	22 31 35

NOTE: Total Cycle Time = Freeze + Harvest      Pressure data is recorded 5 minutes into the freeze cycle.

**PERFORMANCE DATA**

MODEL: KM-61BAH

Supply Voltage: 115/60/1      \*\* Refrigerant: R134A

Total Amperage (Compressor RLA):      Air: 3.4A (2.29A)

Ice Production per cycle: 1.7 lbs, 80 pcs

Ambient Temp (F°/C°)		70 / 21	80 / 27	90 / 32	100 / 38
<b>Kg=lbs x.454</b> <b>Production</b> <b>24 hours</b> <b>(lbs)</b>	Water Temp		Air	Air	Air
	F°/C°				
	50 / 10	71	66	55	64
	70 / 21	65	56	49	48
	90 / 32	58	51	43	38
<b>Cycle Time</b> <b>Freeze</b>	50 / 10	31	34	34	37
	70 / 21	34	39	43	44
	90 / 32	20	21	51	58
<b>Cycle Time</b> <b>Harvest</b>	50 / 10	2.5	2.4	2.4	2.2
	70 / 21	2.4	2.2	2.0	2.0
	90 / 32	2.0	2.0	2.0	2.0
<b>Pressure</b> <b>High Side</b>	50 / 10	104	115	119	121
	70 / 21	119	139	155	159
	90 / 32	135	153	171	185
<b>Pressure</b> <b>Suction</b>	50 / 10	10	11	14	12
	70 / 21	11	13	15	16
	90 / 32	14	17	18	21

NOTE: Total Cycle Time = Freeze + Harvest      Pressure data is recorded 5 minutes into the freeze cycle.

**PERFORMANCE DATA**

MODEL: KM-101BAH

Supply Voltage: 115/60/1

\*\*Refrigerant: R134A

Total Amperage (Compressor RLA):

Air: 5.2A (3.39A)

Ice Production per cycle: 2.31 lbs, 110 pcs

Water Temp F°/C°	Ambient Temp (F°/C°)		
	70 / 21	80 / 27	90 / 32
Kg=lbs x.454 Production 24 hours (lbs)	Air	Air	Air
	50 / 10	109	107
	70 / 21	97	88
90 / 32	87	78	69
Cycle Time Freeze	50 / 10	28	28
	70 / 21	30	33
	90 / 32	20	37
Cycle Time Harvest	50 / 10	2.7	2.5
	70 / 21	2.5	2.1
	90 / 32	2.0	2.0
Pressure High Side	50 / 10	122	127
	70 / 21	150	170
	90 / 32	148	191
Pressure Suction	50 / 10	14	14
	70 / 21	14	19
	90 / 32	17	23
			100 / 38

NOTE: Total Cycle Time = Freeze + Harvest

Pressure data is recorded 5 minutes into the freeze cycle.

**PERFORMANCE DATA**

MODEL: KM-151BAH

Supply Voltage: 115-60-1      \*\*Refrigerant: R134A

Total Amperage (Compressor RLA):

Air: 7A (6.01A)

Water: 6.8 (5.6A)

Ice Production per cycle: 2.75 lbs, 130 pcs

Water Consumption for MWH Condenser:

70/50 (21/10) 103 Gal/ 24hrs

90/70 (32/21) 181 Gal/24hrs

Ambient Temp (F° /C°)	70 / 21		80 / 27		90 / 32		100 / 38	
	Air	Water	Air	Water	Air	Water	Air	Water
<b>Kg=lbs x.454 Production 24 hours (lbs)</b>	50 / 10	146	140	142	139	141	137	141
	70 / 21	139	129	435	121	130	119	129
	90 / 32	129	136	131	111	125	101	121
<b>Cycle Time Freeze</b>	50 / 10	21	22	26	23	26	23	27
	70 / 21	23	26	28	26	29	27	29
	90 / 32	20	28	30	29	31	31	33
<b>Cycle Time Harvest</b>	50 / 10	3.3	3.5	3.3	2.9	3.2	2.5	2.8
	70 / 21	2.9	3.2	2.8	2.0	2.5	2.0	2.4
	90 / 32	2.0	2.0	2.0	2.0	2.2	2.0	2.0
<b>Pressure High Side</b>	50 / 10	114	150	124	128	151	132	154
	70 / 21	128	151	146	161	152	166	154
	90 / 32	148	157	167	182	160	202	167
<b>Pressure Suction</b>	50 / 10	12	13	13	13	13	13	13
	70 / 21	13	13	14	15	14	15	14
	90 / 32	14	14	15	16	15	17	15

NOTE: Total Cycle Time = Freeze + Harvest      Pressure data is recorded 5 minutes into the freeze cycle.

**PERFORMANCE DATA**

MODEL: KM-201B\_H

Total Amperage (Compressor RLA): Air: 6.1A (5.2A) Water: 6.1A (5.2A)

Supply Voltage: 115/60/1

Ice Production per cycle: 4 lbs, 182 pcs

Water Consumption for MWH Condenser:

90/70 (32/21) 226 Gal/24hrs

Ambient Temp (F°/C°)	70 / 21			80 / 27			90 / 32			100 / 38		
	Water Temp F°/C°	Air	Water	Air	Water	Air	Water	Air	Water	Air	Water	
<b>Kg=lbs x.454 Production 24 hours (lbs)</b>	50 / 10	201	215	193	209	190	207	187	203			
	70 / 21	190	207	177	195	165	186	161	182			
	90 / 32	176	192	162	180	150	171	136	157			
<b>Cycle Time Freeze</b>	50 / 10	25	22	26	23	27	23	28	24			
	70 / 21	27	23	30	25	32	26	33	27			
	90 / 32	30	25	31	27	35	29	39	31			
<b>Cycle Time Harvest</b>	50 / 10	3.2	2.5	2.9	2.4	2.8	2.4	2.5	2.2			
	70 / 21	2.8	2.4	2.4	2.2	2.0	2.0	2.0	2.0			
	90 / 32	2.0	2.0	2.0	2.0	2.0	2.0	2.0	2.0			
<b>Pressure High Side</b>	50 / 10	235	285	250	285	255	285	257	285			
	70 / 21	255	285	281	285	303	285	308	285			
	90 / 32	277	285	300	285	323	285	342	285			
<b>Pressure Suction</b>	50 / 10	51	43	52	44	52	44	53	45			
	70 / 21	52	44	54	46	56	48	56	49			
	90 / 32	54	47	56	49	58	51	59	53			

NOTE: Total Cycle Time = Freeze + Harvest  
Pressure data is recorded 5 minutes into the freeze cycle.

**PERFORMANCE DATA**

MODEL: KML-250M\_H

Supply Voltage: 115/60/1

Total Amperage (Compressor RLA): Air: 8.2A (7A) Water: 7.5A (6.7A)

Ice Production per cycle: 6.6 lbs, 360 pcs

Water Consumption for MWH Condenser: 70/50 (21/10) 226 Gal/24hrs

90/70 (32/21) 349 Gal/24hrs

Ambient Temp (F°/C°)	70 / 21		80 / 27		90 / 32		100 / 38	
	Air	Water	Air	Water	Air	Water	Air	Water
<b>Kg=lbs x.454 Production 24 hours (lbs)</b>	Water Temp F°/C°							
	50 / 10	314	292	307	287	305	260	301
	70 / 21	305	260	294	238	284	234	280
	90 / 32	290	245	277	220	267	204	252
<b>Cycle Time Freeze</b>	50 / 10	27	29	29	29	29	33	29
	70 / 21	29	32	30	35	31	36	31
	90 / 32	32	35	32	38	33	41	35
<b>Cycle Time Harvest</b>	50 / 10	4.7	4.1	3.7	4.0	3.6	3.2	3.4
	70 / 21	4.0	3.6	3.0	2.2	2.5	2.2	2.4
	90 / 32	3.7	3.3	2.8	2.1	2.2	2.0	2.0
<b>Pressure High Side</b>	50 / 10	247	261	280	266	280	295	282
	70 / 21	266	290	280	311	280	318	284
	90 / 32	293	319	286	340	285	366	290
<b>Pressure Suction</b>	50 / 10	58	59	61	59	61	61	62
	70 / 21	59	61	62	62	62	62	62
	90 / 32	60	62	63	63	64	64	65

NOTE: Total Cycle Time = Freeze + Harvest

Pressure data is recorded 5 minutes into the freeze cycle.

**PERFORMANCE DATA**

MODEL: KM-251BAH

Supply Voltage: 115/60/1

Total Amperage (Compressor RLA):

Air: 9A (8A)

Ice Production per cycle: 4 lbs, 204 pcs

Ambient Temp (F°/C°)		70 / 21		80 / 27		90 / 32		100 / 38	
Kg=lbs x.454 Production 24 hours (lbs)	Water Temp F°/C°	Air		Air		Air		Air	
	50 / 10	225	217	214	196	214	196	214	196
	70 / 21	214	201	189	184	189	184	189	184
90 / 32	195	178	168	148	168	148	168	148	
Cycle Time Freeze	50 / 10	20	21	21	24	21	24	21	24
	70 / 21	21	23	25	26	25	26	25	26
	90 / 32	24	26	28	30	28	30	28	30
Cycle Time Harvest	50 / 10	5.3	5	5	4.5	5	4.5	5	4.5
	70 / 21	5	4.5	3.7	3.5	3.7	3.5	3.7	3.5
	90 / 32	4.5	4	3.5	3.2	3.5	3.2	3.5	3.2
Pressure High Side	50 / 10	200	223	231	229	231	229	231	229
	70 / 21	231	271	305	309	305	309	305	309
	90 / 32	254	285	323	340	323	340	323	340
Pressure Suction	50 / 10	33	36	37	37	37	37	37	37
	70 / 21	37	43	48	48	48	48	48	48
	90 / 32	40	44	50	52	50	52	50	52

NOTE: Total Cycle Time = Freeze + Harvest  
Pressure data is recorded 5 minutes into the freeze cycle.

**PERFORMANCE DATA**

MODEL: KM-255BAH

Supply Voltage: 115/60/1

Total Amperage (Compressor RLA):

Air: 9A (8.1A)

Ice Production per cycle: 4 lbs, 204 pcs

Ambient Temp (F°/C°)		70 / 21	80 / 27	90 / 32	100 / 38
Kg=lbs x.454 Production 24 hours (lbs)	Water Temp F°/C°	Air	Air	Air	Air
		50 / 10	235	229	227
	70 / 21	227	216	207	202
	90 / 32	207	191	184	163
Cycle Time Freeze	50 / 10	20	21	22	24
	70 / 21	22	24	25	26
	90 / 32	24	25	27	29
Cycle Time Harvest	50 / 10	4.3	4	4	3.5
	70 / 21	4	3.5	3.1	3
	90 / 32	4	3	3	2.7
Pressure High Side	50 / 10	220	238	243	245
	70 / 21	243	274	300	305
	90 / 32	267	293	321	340
Pressure Suction	50 / 10	35	37	38	38
	70 / 21	38	42	45	45
	90 / 32	40	43	47	48

NOTE: Total Cycle Time = Freeze + Harvest  
Pressure data is recorded 5 minutes into the freeze cycle.



**PERFORMANCE DATA**

MODEL: KM-260B\_H

Supply Voltage: 115/60/1

Total Amperage (Compressor RLA): Air: 7.6A (7A) Water: 7.5A (7A)

Ice Production per cycle: 5 lbs, 238 pcs

Water Consumption for MWH Condenser: 70/50 (21/10) 151 Gal/24hrs

90/70 (32/21) 255 Gal/24hrs

Kg=lbs x.454 Production 24 hours (lbs)	70 / 21			80 / 27			90 / 32			100 / 38		
	Air	Water	Water Temp F°/C°	Air	Water	Water	Air	Water	Water	Air	Water	Water
<b>Cycle Time Freeze</b>	263	268	50 / 10	251	261	261	247	259	259	244	254	254
	247	259	70 / 21	226	247	247	208	237	237	203	233	233
	227	242	90 / 32	207	228	228	189	218	218	171	201	201
<b>Cycle Time Harvest</b>	25	21	50 / 10	27	22	22	27	22	22	28	22	22
	27	22	70 / 21	30	17	17	33	28	28	33	24	24
	30	27	90 / 32	31	29	29	36	29	29	40	28	28
<b>Pressure High Side</b>	3.2	2.6	50 / 10	2.9	2.5	2.5	2.8	2.5	2.5	2.5	2.3	2.3
	2.8	2.5	70 / 21	2.4	2.3	2.3	2.0	2.1	2.1	2.0	2.1	2.1
	2.0	2.0	90 / 32	2.0	2.0	2.0	2.0	2.0	2.0	2.0	2.0	2.0
<b>Pressure Suction</b>	217	285	50 / 10	230	285	285	234	285	285	238	285	285
	234	285	70 / 21	257	285	285	276	285	285	281	285	285
	257	285	90 / 32	279	285	285	299	285	285	320	285	285
<b>Pressure Suction</b>	51	46	50 / 10	52	46	46	52	47	47	53	49	49
	52	47	70 / 21	54	47	47	56	48	48	56	49	49
	54	51	90 / 32	56	53	53	58	53	53	59	58	58

NOTE: Total Cycle Time = Freeze + Harvest  
Pressure data is recorded 5 minutes into the freeze cycle.

**PERFORMANCE DATA**

MODEL: KM-280M\_H

Supply Voltage: 115/60/1

Total Amperage (Compressor RLA):

Air: 11.6A (10.2A)      Water: 10A (9.2A)

Ice Production per cycle: 4.7 lbs, 240 pcs

Water Consumption for MWH Condenser:

70/50 (21/10) 209 Gal/24hrs

90/70 (32/21) 318 Gal/24hrs

Ambient Temp (F°/C°)	70 / 21		80 / 27		90 / 32		100 / 38	
	Air	Water	Air	Water	Air	Water	Air	Water
<b>Kg=lbs x.454 Production 24 hours (lbs)</b>	Water Temp F°/C°							
	50 / 10	271	252	263	247	260	242	259
	70 / 21	247	218	246	194	234	188	232
	90 / 32	219	192	237	166	224	141	215
<b>Cycle Time Freeze</b>	50 / 10	22	24	21	25	21	26	21
	70 / 21	25	21	22	31	23	32	23
	90 / 32	30	22	23	37	24	42	25
<b>Cycle Time Harvest</b>	50 / 10	3.0	2.8	3.3	2.7	3.2	2.5	3.2
	70 / 21	2.7	2.3	2.8	2.0	2.5	2.0	2.5
	90 / 32	2.6	2.4	2.7	2.0	2.3	2.0	2.2
<b>Pressure High Side</b>	50 / 10	236	254	280	259	280	262	281
	70 / 21	259	290	280	316	280	321	284
	90 / 32	285	312	284	339	284	361	287
<b>Pressure Suction</b>	50 / 10	45	49	48	50	48	50	49
	70 / 21	50	56	49	61	50	62	51
	90 / 32	54	60	53	65	54	69	57

NOTE: Total Cycle Time = Freeze + Harvest  
Pressure data is recorded 5 minutes into the freeze cycle.

**PERFORMANCE DATA**

MODEL: KM-280MAH-E

Supply Voltage: 220-240/50/1

Total Amperage (Compressor RLA):

Air: 5.1A (4.3A)

Ice Production per cycle: 4.7 lbs, 240 pcs

Water Temp F°/C°	70 / 21			80 / 27			90 / 32			100 / 38		
	Air			Air			Air			Air		
<b>kg=lbs x.454 Production 24 hours (lbs)</b>	50 / 10	258		237			231			229		
	70 / 21	231		196			166			160		
	90 / 32	204		175			142			120		
<b>Cycle Time Freeze</b>	50 / 10	20		22			23			25		
	70 / 21	23		28			31			33		
	90 / 32	30		35			39			45		
<b>Cycle Time Harvest</b>	50 / 10	3.1		3.1			3.1			3.0		
	70 / 21	3.1		3.0			2.9			2.9		
	90 / 32	3.0		2.5			2.9			2.9		
<b>Pressure High Side</b>	50 / 10	245		262			267			269		
	70 / 21	267		296			320			325		
	90 / 32	290		315			341			360		
<b>Pressure Suction</b>	50 / 10	55		57			58			58		
	70 / 21	58		62			65			66		
	90 / 32	61		64			68			70		

NOTE: Total Cycle Time = Freeze + Harvest  
Pressure data is recorded 5 minutes into the freeze cycle.

**PERFORMANCE DATA**

MODEL: KM-320M\_H

Supply Voltage: 115/60/1

Total Amperage (Compressor RLA): Air: 9.7A (7A)

Water: 9.2A (8.2A)

Ice Production per cycle: 7.2 lbs, 360 pcs

Water Consumption for MWH Condenser: 70/50 (21/10)

327 Gal/24hrs

90/70 (32/21) 528 Gal/24hrs

Ambient Temp (F°/C°)	70 / 21		80 / 27		90 / 32		100 / 38	
	Water Temp F°/C°	Air	Water	Air	Water	Air	Water	Air
<b>Kg=lbs x.454 Production 24 hours (lbs)</b>	50 / 10	325	352	315	349	311	348	304
	70 / 21	311	348	293	342	278	337	272
	90 / 32	287	324	265	309	251	308	226
<b>Cycle Time Freeze</b>	50 / 10	29	27	31	28	31	28	32
	70 / 21	31	28	34	30	37	31	38
	90 / 32	35	30	38	32	41	33	45
<b>Cycle Time Harvest</b>	50 / 10	5.5	5.0	4.8	4.5	4.6	4.4	3.6
	70 / 21	4.6	4.4	3.5	3.5	2.5	2.8	2.5
	90 / 32	4.2	4.0	3.4	3.4	2.3	2.6	2.1
<b>Pressure High Side</b>	50 / 10	216	263	230	263	235	263	237
	70 / 21	235	263	259	263	280	263	285
	90 / 32	255	265	277	265	299	265	317
<b>Pressure Suction</b>	50 / 10	52	53	53	54	53	54	53
	70 / 21	53	54	54	56	55	57	55
	90 / 32	54	55	54	56	56	58	56

NOTE: Total Cycle Time = Freeze + Harvest

Pressure data is recorded 5 minutes into the freeze cycle.

**PERFORMANCE DATA**

MODEL: KM-320MAH-E

Total Amperage (Compressor RLA):

Air: 5.1A (2.9A)

Supply Voltage: 220-240/50/1

Ice Production per cycle: 8 lbs, 360 pcs

Kg=lbs x.454 Production 24 hours (lbs)	Water Temp F°/C°	70 / 21			80 / 27			90 / 32			100 / 38		
		Air			Air			Air			Air		
	50 / 10	293	279	275	273								
	70 / 21	275	252	232	228								
	90 / 32	255	234	213	196								
Cycle Time Freeze	50 / 10	34	36	37	37								
	70 / 21	37	42	47	47								
	90 / 32	39	42	47	48								
Cycle Time Harvest	50 / 10	5.8	5.1	4.9	3.9								
	70 / 21	4.9	3.8	2.8	2.8								
	90 / 32	4.5	3.8	2.7	2.5								
Pressure High Side	50 / 10	210	229	235	233								
	70 / 21	235	268	295	298								
	90 / 32	253	276	308	320								
Pressure Suction	50 / 10	56	57	57	57								
	70 / 21	57	59	60	60								
	90 / 32	58	60	61	62								

NOTE: Total Cycle Time = Freeze + Harvest

Pressure data is recorded 5 minutes into the freeze cycle.

**PERFORMANCE DATA**

MODEL: KML-350M\_H

Supply Voltage: 115/60/1

Total Amperage (Compressor RLA): Air: 11.5A (11.5A) Water: 10.5A (10.5A)

Ice Production per cycle: 7.3 lbs, 360 pcs

Water Consumption for MWH Condenser:

70/50 (21/10) 397 Gal/24hrs

90/70 (32/21) 457 Gal/24hrs

Ambient Temp (F°/C°)	70 / 21		80 / 27		90 / 32		100 / 38	
	Air	Water	Air	Water	Air	Water	Air	Water
<b>Kg=lbs x.454 Production 24 hours (lbs)</b>	350 342 309	352 349 324	344 331 287	349 342 309	342 322 282	348 337 308	328 313 245	337 330 281
<b>Cycle Time Freeze</b>	25 27 30	27 28 30	26 29 33	28 30 32	27 31 35	4.4 2.8 2.6	28 32 38	29 31 35
<b>Cycle Time Harvest</b>	4.0 3.4 3.2	5.0 4.4 4.0	3.6 2.6 2.8	4.5 3.5 3.4	3.4 2.0 2.0	2.8 2.0 2.0	2.6 2.0 2.0	3.6 2.8 2.4
<b>Pressure High Side</b>	240 261 285	263 263 263	256 288 310	263 263 265	261 310 333	263 263 265	284 315 355	264 263 267
<b>Pressure Suction</b>	48 50 53	53 54 55	50 53 56	54 56 56	50 55 59	54 57 58	51 56 62	54 57 59

NOTE: Total Cycle Time = Freeze + Harvest

Pressure data is recorded 5 minutes into the freeze cycle.

**PERFORMANCE DATA**

MODEL: KML-351M\_H

Supply Voltage: 115/60/1

Total Amperage (Compressor RLA):

Air: 13.2A (11.5A) Water: 7.5A (6.7A)

Ice Production per cycle: 7.3 lbs, 360 pcs

Water Consumption for MWH Condenser:

70/50 (21/10) 273 Gal/24hrs

90/70 (32/21) 428 Gal/24hrs

Kg=lbs x.454 Production 24 hours (lbs)	70 / 21			80 / 27			90 / 32			100 / 38			
	Water Temp F°/C°	Air (S-0)	Air (T-0,etc.)	Water	Air (S-0)	Air (T-0,etc.)	Water	Air (S-0)	Air (T-0,etc.)	Water	Air (S-0)	Air (T-0,etc.)	Water
<b>Cycle Time Freeze</b>	50 / 10	334	350	345	312	344	341	312	342	340	28	27	26
	70 / 21	312	342	340	284	331	333	260	322	327	34	31	28
	90 / 32	291	309	318	268	287	303	241	282	300	37	35	31
<b>Cycle Time Harvest</b>	50 / 10	25	25	25	27	26	26	28	27	26	4.4	3.4	4.3
	70 / 21	28	27	26	31	29	27	34	31	28	3.4	2.0	3.4
	90 / 32	31	30	28	34	33	30	37	35	31	3.4	2.0	3.4
<b>Pressure High Side</b>	50 / 10	228.8	240	268.6	247	256	269	253	261	269	257	284	272
	70 / 21	253	261	269	285	288	270	312	310	270	318	315	272
	90 / 32	281	285	275	311	310	279	339	333	278	364	355	285
<b>Pressure Suction</b>	50 / 10	52.4	48	54	53	50	54	54	50	54	54	51	54
	70 / 21	54	50	54	55	53	54	56.2	55	55	57	56	55
	90 / 32	55	53	55	57	56	55	58	59	55	59.6	62	56

NOTE: Total Cycle Time = Freeze + Harvest Pressure data is recorded 5 minutes into the freeze cycle.

**PERFORMANCE DATA**

MODEL: KMD-410M\_H

Total Amperage (Compressor RLA): Air: 8.0A (7.5A) Water: 6.5A (6A)

Supply Voltage: 115/60/1

Ice Production per cycle: 8.5 lbs, 410 pcs

Water Consumption for MWH Condenser: 70/50 (21/10) 120 Gal/24hrs

90/70 (32/21) 89 Gal/24hrs

Kg=lbs x.454 Production 24 hours (lbs)	70 / 21			80 / 27			90 / 32			100 / 38		
	Water Temp F°/C°	Air	Water	Air	Water	Air	Water	Air	Water	Air	Water	Water
<b>Cycle Time Freeze</b>	50 / 10	27	25	28	25	29	26	29	26	29	26	26
	70 / 21	29	26	31	27	34	29	34	29	34	29	29
	90 / 32	32	28	34	30	37	31	40	33	40	33	33
<b>Cycle Time Harvest</b>	50 / 10	3.0	2.3	2.8	2.2	2.7	2.2	2.4	2.2	2.4	2.1	2.1
	70 / 21	2.7	2.2	2.3	2.1	2.0	2.0	2.0	2.0	2.0	2.0	2.0
	90 / 32	2.6	2.2	2.4	2.1	2.0	2.0	2.0	2.0	2.0	2.0	2.0
<b>Pressure High Side</b>	50 / 10	216	239	232	239	237	240	240	240	240	241	241
	70 / 21	237	240	265	240	288	241	293	241	293	242	242
	90 / 32	261	243	287	246	311	246	333	246	333	250	250
<b>Pressure Suction</b>	50 / 10	45	43	47	44	48	44	49	44	49	46	46
	70 / 21	48	44	51	46	54	48	55	48	55	49	49
	90 / 32	52	48	55	51	58	52	62	52	62	60	60

NOTE: Total Cycle Time = Freeze + Harvest  
Pressure data is recorded 5 minutes into the freeze cycle.



**PERFORMANCE DATA**

MODEL: KML-450M\_H

Supply Voltage: 115/60/1

Total Amperage (Compressor RLA): Air: 13.3A (11.6A) Water: 10.6A (9.6A) Ice Production per cycle: 6.6 lbs, 360 pcs

Water Consumption for MWH Condenser: 70/50 (21/10) 355 Gal/24hrs 90/70 (32/21) 614 Gal/24hrs

Ambient Temp (F°/C°)	70 / 21		80 / 27		90 / 70 (32/21)		100 / 38	
	Air	Water	Air	Water	Air	Water	Air	Water
<b>Kg=lbs x.454 Production 24 hours (lbs)</b>	Water Temp F°/C°							
	50 / 10	432	433	429	404	428	390	417
	70 / 21	404	428	422	367	407	332	409
	90 / 32	381	402	385	353	384	302	354
<b>Cycle Time Freeze</b>	50 / 10	20	20	20	22	21	23	21
	70 / 21	22	21	21	24	22	26	22
	90 / 32	23	22	23	25	24	28	25
<b>Cycle Time Harvest</b>	50 / 10	3.0	3.5	3.2	2.8	3.1	2.6	3.2
	70 / 21	2.7	3.1	2.5	2.3	2.0	2.0	2.0
	90 / 32	2.6	2.9	2.6	2.4	2.0	2.0	2.0
<b>Pressure High Side</b>	50 / 10	250	280	280	270	280	276	283
	70 / 21	276	280	280	311	280	340	284
	90 / 32	293	286	289	316	290	350	295
<b>Pressure Suction</b>	50 / 10	42	47	47	45	48	46	50
	70 / 21	46	48	48	52	49	56	50
	90 / 32	49	52	55	52	55	59	60

NOTE: Total Cycle Time = Freeze + Harvest Pressure data is recorded 5 minutes into the freeze cycle.

**PERFORMANCE DATA**

MODEL: KMD-450M\_H

Supply Voltage: 115/60/1

Total Amperage (Compressor RLA): Air: 10.0A (8.6A) Water: 8.5A (7.8A)

Ice Production per cycle: 9.3 lbs, 432 pcs

Water Consumption for MWH Condenser: 70/50 (21/10) 460 Gal/24hrs 90/70 (32/21) 597 Gal/24hrs

Ambient Temp (F°/C°)	70 / 21		80 / 27		90 / 70 (32/21)		90 / 32		100 / 38	
	Air	Water	Air	Water	Air	Water	Air	Water	Air	Water
<b>Kg=lbs x .454 Production 24 hours (lbs)</b>	457 436 398	460 447 415	441 409 365	450 429 389	436 387 344	447 415 377	425 377 304	436 406 343	425 377 304	436 406 343
<b>Cycle Time Freeze</b>	26 29 33	28 28 30	28 32 36	28 29 32	29 34 39	28 30 33	30 35 43	29 31 35	30 35 43	29 31 35
<b>Cycle Time Harvest</b>	3.6 3.1 3.0	2.7 2.5 2.4	3.2 2.5 2.6	2.5 2.2 2.3	3.1 2.0 2.0	2.5 2.0 2.0	2.6 2.0 2.0	2.3 2.0 2.0	2.6 2.0 2.0	2.3 2.0 2.0
<b>Pressure High Side</b>	245 264 288	274 273 279	260 289 311	274 273 281	264 310 333	273 272 279	284 315 355	277 274 281	284 315 355	277 274 281
<b>Pressure Suction</b>	53 55 56	55 56 57	54 57 58	55 56 57	55 59 60	56 57 58	55 59 61	56 57 59	55 59 61	56 57 59

NOTE: Total Cycle Time = Freeze + Harvest Pressure data is recorded 5 minutes into the freeze cycle.

**PERFORMANCE DATA**

MODEL: KML-451M\_H

Supply Voltage: 115/60/1

Total Amperage (Compressor RLA): Air: 9.5A (7.9A) Water: 9.8A (9.0A)

Ice Production per cycle: 7.6 lbs, 360 pcs

Water: Consumption for MWH Condenser: 70/50 (21/10) 319 Gal/24hrs

90/70 (32/21) 548 Gal/24hrs

Ambient Temp (F°/C°)	70 / 21		80 / 27		90 / 32		100 / 38	
	Air	Water	Air	Water	Air	Water	Air	Water
<b>Kg=lbs x.454 Production 24 hours (lbs)</b>	Water Temp F°/C°							
	50 / 10	429	391	402	387	402	377	393
	70 / 21	402	366	399	349	397	340	392
	90 / 32	384	328	373	313	374	279	352
<b>Cycle Time Freeze</b>	50 / 10	23	23	21	23	21	24	22
	70 / 21	23	25	22	29	24	28	23
	90 / 32	25	28	24	30	24	32	25
<b>Cycle Time Harvest</b>	50 / 10	4.5	3.7	3.9	3.6	3.8	3.2	3.2
	70 / 21	3.6	3.1	3.1	2.7	2.6	2.7	2.5
	90 / 32	3.5	3.2	3.1	2.7	2.4	2.7	2.2
<b>Pressure High Side</b>	50 / 10	218	243	260	248	260	253	264
	70 / 21	248	279	261	294	261	311	263
	90 / 32	276	305	271	332	270	357	278
<b>Pressure Suction</b>	50 / 10	45	44	44	45	45	47	46
	70 / 21	45	49	46	53	50	54	48
	90 / 32	51	55	50	59	51	64	55

NOTE: Total Cycle Time = Freeze + Harvest  
Pressure data is recorded 5 minutes into the freeze cycle.

**PERFORMANCE DATA**

MODEL: KMD-460M\_H

Total Amperage (Compressor RLA): Air: 10.0A (9.5A) Water: xxA (xxA)

Supply Voltage: 115/60/1

Ice Production per cycle: 9.6 lbs, 432 pcs

Water Consumption for MWH Condenser: 70/50 (21/10) xxx Gal/24hrs 90/70 (32/21) xxx Gal/24hrs

Ambient Temp (F°/C°)	70 / 21		80 / 27		90/70 (32/21)		90 / 32		100 / 38	
	Water Temp F°/C°	Air	Water	Air	Water	Air	Water	Air	Water	Water
<b>Kg=lbs x.454 Production 24 hours (lbs)</b>	50 / 10	457	N/A	441	N/A	436	N/A	425	N/A	N/A
	70 / 21	436	N/A	409	N/A	387	N/A	377	N/A	N/A
	90 / 32	398	N/A	365	N/A	344	N/A	304	N/A	N/A
<b>Cycle Time Freeze</b>	50 / 10	26	N/A	28	N/A	29	N/A	30	N/A	N/A
	70 / 21	29	N/A	32	N/A	34	N/A	35	N/A	N/A
	90 / 32	33	N/A	36	N/A	39	N/A	43	N/A	N/A
<b>Cycle Time Harvest</b>	50 / 10	3.6	N/A	3.2	N/A	3.1	N/A	2.6	N/A	N/A
	70 / 21	3.1	N/A	2.5	N/A	2.0	N/A	2.0	N/A	N/A
	90 / 32	3.0	N/A	2.6	N/A	2.0	N/A	2.0	N/A	N/A
<b>Pressure High Side</b>	50 / 10	245	N/A	260	N/A	264	N/A	268	N/A	N/A
	70 / 21	264	N/A	289	N/A	310	N/A	315	N/A	N/A
	90 / 32	288	N/A	311	N/A	333	N/A	355	N/A	N/A
<b>Pressure Suction</b>	50 / 10	53	N/A	54	N/A	55	N/A	55	N/A	N/A
	70 / 21	55	N/A	57	N/A	59	N/A	59	N/A	N/A
	90 / 32	56	N/A	58	N/A	60	N/A	61	N/A	N/A

NOTE: Total Cycle Time = Freeze + Harvest Pressure data is recorded 5 minutes into the freeze cycle.

**PERFORMANCE DATA**

MODEL: KM-461M\_H

Supply Voltage: 115/60/1

Total Amperage (Compressor RLA): Air: 12A (10.6A) Water: 12.1A (9.4A) Remote: 10.4A (10.4A) Ice Production per cycle: 10.4 lbs, 480 pcs  
 Water Consumption for MWH Condenser: 70/50 (21/10) 250 Gal/24hrs 90/70 (32/21) 503 Gal/24hrs

Ambient Temp (F°/C°)	70 / 21			80 / 27			90 / 32			100 / 38			
	Water Temp F°/C°	Air	Water	Remote	Air	Water	Remote	Air	Water	Remote	Air	Water	Remote
<b>Kg=lbs x.454 Production 24 hours (lbs)</b>	50/10	452	438	446	438	433	435	434	432	431	423	420	421
	70/21	434	432	431	409	423	412	389	416	396	380	408	387
	90/32	398	404	399	368	385	373	349	382	359	313	350	325
<b>Cycle Time Freeze</b>	50/10	28	29	30	30	29	31	30	30	31	31	30	32
	70/21	30	30	31	33	31	34	35	32	36	36	32	36
	90/32	33	32	34	36	33	37	38	34	39	41	36	41
<b>Cycle Time Harvest</b>	50/10	4.4	4.9	4.7	3.9	4.4	4.1	3.7	4.2	3.9	2.9	3.5	3.1
	70/21	3.7	4.2	3.9	2.8	3.4	2.9	2.0	2.7	2.0	2.0	2.7	2.0
	90/32	3.5	4.0	3.7	2.9	3.5	3.1	2.0	2.6	2.0	2.0	2.5	2.0
<b>Pressure High Side</b>	50/10	238	259	211	255	260	226	260	260	230	262	262	233
	70/21	260	260	230	289	262	255	313	263	276	318	264	281
	90/32	283	265	251	308	268	274	334	269	296	353	274	315
<b>Pressure Suction</b>	50/10	50	52	50	52	53	52	52	53	52	53	55	54
	70/21	52	53	52	55	55	55	58	57	58	59	58	59
	90/32	56	57	57	59	59	61	62	61	63	65	64	68

NOTE: Total Cycle Time = Freeze + Harvest Pressure data is recorded 5 minutes into the freeze cycle.

**PERFORMANCE DATA**

MODEL: DKM-500B\_H

Supply Voltage: 115/60/1

Total Amperage (Compressor RLA):

Air: 13.3A (11.6A)

Water: 10 (10A)

Ice Production per cycle: 7.5 lbs, 360 pcs

Water Consumption for BWH Condenser:

70/50 (21/10) 319 Gal/24hrs

90/70 (32/21) 606 Gal/24hrs

Ambient Temp (F°/C°)		70 / 21		80 / 27		90 / 32		100 / 38	
		Air	Water	Air	Water	Air	Water	Air	Water
<b>Kg=lbs x.454 Production 24 hours (lbs)</b>	50/10	466	455	453	451	448	450	390	390
	70/21	448	450	425	444	406	439	399	430
	90/32	420	419	395	399	376	399	348	363
<b>Cycle Time Freeze</b>	50/10	19	19	19	19	19	19	23	23
	70/21	19	19	21	21	22	22	22	22
	90/32	21	21	23	23	26	24	26	26
<b>Cycle Time Harvest</b>	50/10	3.9	3.9	3.5	3.5	3.3	3.3	2.6	2.6
	70/21	3.3	3.3	2.6	2.6	2.0	2.0	2.0	2.0
	90/32	3.1	3.1	2.7	2.7	2.0	2.0	2.0	2.0
<b>Pressure High Side</b>	50/10	262	267.8	277	268	282	268	284	284
	70/21	282	268	308	267	330	267	335	267
	90/32	305	268	329	268	353	268	374	269
<b>Pressure Suction</b>	50/10	56	43.4	57	44	57	44	57	44
	70/21	57	44	58	44	59	45	60	45
	90/32	58	45	60	46	61	46	62	47

NOTE: Total Cycle Time = Freeze + Harvest  
Pressure data is recorded 5 minutes into the freeze cycle.

**PERFORMANCE DATA**

MODEL: KM-500MAH-E

Supply Voltage: 220-240/50/1

Ice Production per cycle: 9.5 lbs, 480 pcs

Total Amperage (Compressor RLA): Air: 5.5A (5.5A)

Ambient Temp (F°/C°)		70 / 21	80 / 27	90 / 32	100 / 38
<b>Kg=lbs x.454 Production 24 hours (lbs)</b>	Water Temp F°/C°	Air	Air	Air	Air
	50 / 10	480	454	446	438
	70 / 21	446	402	365	355
	90 / 32	403	360	321	281
<b>Cycle Time Freeze</b>	50 / 10	29	31	32	33
	70 / 21	32	36	39	40
	90 / 32	37	41	44	50
<b>Cycle Time Harvest</b>	50 / 10	3.4	3.3	3.3	3.3
	70 / 21	3.3	3.1	2.9	2.9
	90 / 32	3.2	3.0	2.9	2.8
<b>Pressure High Side</b>	50 / 10	250	263	268	273
	70 / 21	268	291	310	316
	90 / 32	23	316	336	360
<b>Pressure Suction</b>	50 / 10	50	52	53	53
	70 / 21	53	56	59	59
	90 / 32	55	57	61	62

NOTE: Total Cycle Time = Freeze + Harvest

Pressure data is recorded 5 minutes into the freeze cycle.

**PERFORMANCE DATA**

MODEL: KM-501M\_H

Supply Voltage: 115/60/1

Total Amperage (Compressor RLA):

Air: 13A (11A) Water: 10A (10A)

Remote: 15A (11A) Ice Production per cycle: 9.5 lbs, 480 pcs

Water Consumption for MWH Condenser:

70/50 (21/10) 390 Gal/24hrs

90/70 (32/21) 670 Gal/24hrs

	70 / 21			80 / 27			90 / 32			100 / 38			
	Water Temp F°/C°	Air	Water	Remote	Air	Water	Remote	Air	Water	Remote	Air	Water	Remote
<b>Kg=lbs x.454 Production 24 hours (lbs)</b>	50 / 10	498	498	482	480	496	476	474	495	475	463	480	458
	70 / 21	474	495	475	442	491	465	416	488	457	406	479	446
	90 / 32	433	465	437	397	447	412	372	449	410	332	413	367
<b>Cycle Time Freeze</b>	50 / 10	26	26	26	27	26	27	28	26	27	29	27	28
	70 / 21	28	26	27	30	27	29	32	27	30	33	27	31
	90 / 32	31	28	30	34	29	32	36	29	33	39	31	36
<b>Cycle Time Harvest</b>	50 / 10	4.5	4.0	4.5	4.0	3.6	4.0	3.9	3.4	3.9	3.2	2.8	3.0
	70 / 21	3.9	3.4	3.9	3.0	2.6	3.0	2.3	2.0	2.3	2.3	2.0	2.3
	90 / 32	3.6	3.2	3.5	3.2	2.8	3.0	2.3	2.0	2.1	2.3	2.0	2.0
<b>Pressure High Side</b>	50 / 10	235	275	220	250	275	231	254	275	235	257	282	241
	70 / 21	254	275	235	279	275	254	300	275	270	305	279	276
	90 / 32	276	289	259	298	296	280	321	293	296	340	310	320
<b>Pressure Suction</b>	50 / 10	45	45	50	47	45	50	47	45	51	47	47	51
	70 / 21	47	45	51	50	45	51	53	45	52	53	46	52
	90 / 32	49	49	52	52	51	53	55	50	54	56	55	55

NOTE: Total Cycle Time = Freeze + Harvest Pressure data is recorded 5 minutes into the freeze cycle.



**PERFORMANCE DATA**

MODEL: KM-515M\_H

Supply Voltage: 115/60/1

Total Amperage (Compressor RLA):

Air: 11.7A (10.3A)    Water: 9.6A (9.2A)    Remote: 11.3A (9.7A) Ice Production per cycle: 10.3 lbs, 480 pcs

Water Consumption for MWH Condenser:

70/50 (21/10) 352 Gal/24hrs    90/70 (32/21) 546 Gal/24hrs

	70 / 21			80 / 27			90 / 32			100 / 38			
	Water Temp F°/C°	Air	Water	Remote	Air	Water	Remote	Air	Water	Remote	Air	Water	Remote
<b>Kg=lbs x.454 Production 24 hours (lbs)</b>	50/10 70/21 90/32	501 482 447	500 493 465	491 480 443	486 456 416	494 483 445	482 465 417	482 435 396	493 475 441	480 452 408	472 426 361	481 467 409	465 442 368
<b>Cycle Time Freeze</b>	50/10 70/21 90/32	26 27 30	29 29 30	26 27 30	27 30 33	29 29 31	27 29 32	27 32 35	29 29 31	27 31 34	28 33 37	30 30 33	28 31 36
<b>Cycle Time Harvest</b>	50/10 70/21 90/32	4.4 3.9 3.8	3.8 3.5 3.4	5.0 4.3 4.1	4.0 3.2 3.4	3.6 3.0 3.1	4.5 3.4 3.6	3.9 2.7 2.7	3.5 2.7 2.7	4.3 2.7 2.7	3.4 2.7 2.7	3.1 2.7 2.7	3.6 2.7 2.7
<b>Pressure High Side</b>	50/10 70/21 90/32	226 250 278	270 271 274	216 234 252	244 282 306	271 272 276	230 257 272	250 308 335	271 273 277	234 277 294	254 314 359	272 274 280	235 281 309
<b>Pressure Suction</b>	50/10 70/21 90/32	45 49 54	50 52 56	47 50 52	48 55 60	51 54 59	49 54 54	49 59 64	52 56 61	50 57 58	50 60 69	53 57 65	50 57 59

NOTE: Total Cycle Time = Freeze + Harvest

Pressure data is recorded 5 minutes into the freeze cycle.

**PERFORMANCE DATA**

MODEL: KM-515MAH-E

Supply Voltage: 220-240/50/1

Total Amperage (Compressor RLA): Air: 7.2A (7.1A)

Ice Production per cycle: 10.2 lbs, 480 pcs

Ambient Temp (F°/C°)	70 / 21	80 / 27	90 / 32	100 / 38
Water Temp	Air	Air	Air	Air
F°/C°				
<b>Kg=lbs x.454</b>				
<b>Production</b>	513	490	482	474
<b>24 hours</b>	482	442	408	398
<b>(lbs)</b>	441	401	366	328
<b>Cycle Time</b>	26	28	28	29
<b>Freeze</b>	28	31	33	34
	32	35	37	40
<b>Cycle Time</b>	3.4	3.3	3.2	3.1
<b>Harvest</b>	3.2	3.0	2.9	2.9
	3.2	3.1	2.9	2.9
<b>Pressure</b>	245	262	267	271
<b>High Side</b>	267	296	320	326
	294	321	346	370
<b>Pressure</b>	50	53	54	54
<b>Suction</b>	54	60	65	65
	57	61	67	69

NOTE: Total Cycle Time = Freeze + Harvest  
 Pressure data is recorded 5 minutes into the freeze cycle.

**PERFORMANCE DATA**

MODEL: KM-600MAH

Supply Voltage: 115-120/60/1

Total Amperage (Compressor RLA): Air: 12A (10.3A)

Ice Production per cycle: 14.3 lbs, 720 pcs

Ambient Temp (F°/C°)	70 / 21		80 / 27		90 / 32		100 / 38	
	Water Temp F°/C°	Air	Air	Air	Air	Air	Air	Air
<b>Kg=lbs x.454</b>								
<b>Production 24 hours (lbs)</b>	50 / 10 70 / 21 90 / 32	592 566 516	572 532 474	566 503 447	551 490 396			
<b>Cycle Time Freeze</b>	50 / 10 70 / 21 90 / 32	33 35 38	34 38 42	35 40 44	36 41 48			
<b>Cycle Time Harvest</b>	50 / 10 70 / 21 90 / 32	4.2 3.6 3.4	3.7 2.7 2.9	3.6 2.0 2.0	2.9 2.0 2.0			
<b>Pressure High Side</b>	50 / 10 70 / 21 90 / 32	238 259 290	254 287 319	259 310 342	266 318 372			
<b>Pressure Suction</b>	50 / 10 70 / 21 90 / 32	55 56 58	56 58 60	56 59 61	57 59 62			

NOTE: Total Cycle Time = Freeze + Harvest  
Pressure data is recorded 5 minutes into the freeze cycle.

**PERFORMANCE DATA**

MODEL: KML-600M\_H

Supply Voltage: 208-230/60/1 (3 wire w/neutral for 115V)

Total Amperage (Compressor RLA):

Air: 9.5A (9.5A)

Water: 8.3A (8.3A)

Remote: 9.5 (9.5A)

Ice Production per cycle: 10 lbs, 480 pcs

Water Consumption for MWH Condenser:

70/50 (21/10) 344 Gal/24hrs

90/70 (32/21) 561 Gal/24hrs

Ambient Temp (F°/C°)	70 / 21			80 / 27			90 / 32			100 / 38		
	Air	Water	Remote	Air	Water	Remote	Air	Water	Remote	Air	Water	Remote
<b>Kg=lbs x.454 Production 24 hours (lbs)</b>	631 599 542	602 590 559	635 613 574	606 556 492	593 573 536	618 585 540	575 513 458	590 546 525	613 550 518	540 506 401	535 552 492	602 551 478
<b>Cycle Time Freeze</b>	20 21 24	21 22 23	20 20 21	21 23 26	21 22 24	20 21 23	22 24 27	22 23 25	20 21 23	24 25 30	22 23 26	21 21 25
<b>Cycle Time Harvest</b>	3.5 3.1 2.9	3.1 2.8 2.7	3.5 3.2 2.9	3.2 2.5 2.6	2.9 2.4 2.4	3.3 2.8 2.6	2.9 2.0 2.0	2.8 2.0 2.0	3.2 2.5 2.2	2.5 2.0 2.0	2.6 2.0 2.0	3.2 2.4 2.0
<b>Pressure High Side</b>	250 271 302	280 280 287	220 232 255	266 298 332	280 280 291	229 247 274	280 320 354	280 280 289	232 260 286	310 328 385	284 282 298	239 266 310
<b>Pressure Suction</b>	38 41 47	40 41 44	32 35 41	40 45 51	40 41 46	34 39 46	41 48 54	41 42 46	35 42 49	43 49 60	42 43 50	37 44 55

NOTE: Total Cycle Time = Freeze + Harvest  
Pressure data is recorded 5 minutes into the freeze cycle.

**PERFORMANCE DATA**

MODEL: KML-600MWH Serial LO-M1

Supply Voltage: 208-230/60/1 (3 wire w/neutral for 115V)

Total Amperage (Compressor RLA):

Water: 8.9A (8.3A)

Ice Production per cycle: 10 lbs, 480 pcs

Water Consumption for MWH Condenser:

70/50 (2.1/10) 412 Gal/24hrs

90/70 (32/21) 712 Gal/24hrs

Ambient Temp (F°/C°)		70 / 21	80 / 27	90/70 (32/21)	100 / 38
Kg=lbs x.454 Production 24 hours (lbs)	Water Temp F°/C°	Water	Water	Water	Water
		50 / 10	572	553	547
	70 / 21	547	515	488	486
	90 / 32	534	513	481	475
Cycle Time Freeze	50 / 10	21	22	22	22
	70 / 21	22	22	23	23
	90 / 32	23	24	25	26
Cycle Time Harvest	50 / 10	3.9	3.6	3.5	3.5
	70 / 21	3.5	2.9	2.5	2.4
	90 / 32	3.2	2.8	2.2	2.0
Pressure High Side	50 / 10	270	272	272	275
	70 / 21	272	275	278	280
	90 / 32	280	285	287	295
Pressure Suction	50 / 10	35	36	36	39
	70 / 21	36	37	38	40
	90 / 32	42	46	46	53

NOTE: Total Cycle Time = Freeze + Harvest  
Pressure data is recorded 5 minutes into the freeze cycle.

**PERFORMANCE DATA**

MODEL: KM-630M\_H

Supply Voltage: 208-230/60/1 (3 wire w/neutral for 115V)

Total Amperage (Compressor RLA):

Air: 7.5A (6A)      Water: 6.5A (6A)

Remote: 9.5A (6A)      Ice Production per cycle: 14.3 lbs, 720 pcs

Water Consumption for MWH Condenser:

70/50 (21/10)      354 Gal/24hrs

90/70 (32/21)      536 Gal/24hrs

Ambient Temp (F°/C°)	70 / 21			80 / 27			90 / 32			100 / 38			
	Water Temp F°/C°	Air	Water	Remote	Air	Water	Remote	Air	Water	Remote	Air	Water	Remote
<b>Kg=lbs x.454 Production 24 hours (lbs)</b>	50 / 10	600	621	603	571	607	580	562	603	573	554	590	564
	70 / 21	562	603	573	512	578	532	470	558	499	459	548	489
	90 / 32	514	563	531	466	532	491	422	514	457	378	473	418
<b>Cycle Time Freeze</b>	50 / 10	31	31	31	33	32	33	34	32	33	35	33	34
	70 / 21	34	32	33	37	34	36	40	35	39	41	36	39
	90 / 32	38	35	37	41	37	40	44	38	43	48	41	47
<b>Cycle Time Harvest</b>	50 / 10	4.4	3.8	4.1	4.0	3.5	3.7	3.8	3.4	3.6	3.1	3.4	3.0
	70 / 21	3.8	3.4	3.6	3.0	2.8	2.9	2.4	2.3	2.4	2.4	2.3	2.4
	90 / 32	3.5	3.1	3.3	2.9	2.7	2.8	2.2	2.1	2.2	2.0	2.0	2.0
<b>Pressure High Side</b>	50 / 10	245	280	232	262	280	238	267	280	240	272	282	249
	70 / 21	267	280	240	296	280	251	320	280	260	327	285	266
	90 / 32	296	286	263	324	288	281	349	288	288	375	295	313
<b>Pressure Suction</b>	50 / 10	43	47	42	44	47	42	44	47	42	44	48	44
	70 / 21	44	47	42	46	48	43	47	48	43	47	48	44
	90 / 32	46	48	45	47	49	47	49	49	47	50	50	50

NOTE: Total Cycle Time = Freeze + Harvest      Pressure data is recorded 5 minutes into the freeze cycle.

**PERFORMANCE DATA**

MODEL: KM-630MAH-E

Supply Voltage: 220-240/50/1

Total Amperage (Compressor RLA): Air: 9A (8.1A)

Ice Production per cycle: 14.3 lbs, 720 pcs

Ambient Temp (F°/C°)	70 / 21	80 / 27	90 / 32	100 / 38
<b>Water Temp</b>	Air	Air	Air	Air
<b>Kg=lbs x.454</b>				
<b>Production</b>	624	587	576	568
<b>24 hours</b>	576	513	460	447
<b>(lbs)</b>	520	463	406	357
<b>Cycle Time</b>	32	35	35	37
<b>Freeze</b>	35	40	44	45
	42	47	51	57
<b>Cycle Time</b>	3	3	3	3
<b>Harvest</b>	3	3	2.9	2.8
	3	3	2.9	2.8
<b>Pressure</b>	270	286	291	291
<b>High Side</b>	291	318	340	344
	309	330	356	370
<b>Pressure</b>	50	50	51	51
<b>Suction</b>	51	51	52	52
	52	53	54	55

NOTE: Total Cycle Time = Freeze + Harvest Pressure data is recorded 5 minutes into the freeze cycle.

**PERFORMANCE DATA**

MODEL: KML-631M\_H

Supply Voltage: 208-230/60/1 (3 wire w/neutral for 115V)

Total Amperage (Compressor RLA):

Air: 7.6A (6.4A)      Water: 6.8A (6.1A)

Remote: 7.8A (6.4A)      Ice Production per cycle: 9.7 lbs, 480 pcs

Water Consumption for MWH Condenser:

70/50 (2.1/1.0)      448 Gal/24hrs

90/70 (32/21)      750 Gal/24hrs

Kg=lbs x.454 Production 24 hours (lbs)	70 / 21			80 / 27			90 / 32			100 / 38		
	Air	Water	Remote	Air	Water	Remote	Air	Water	Remote	Air	Water	Remote
50 / 10	575	632	636	558	632	626	553	631	622	543	611	605
70 / 21	553	631	622	525	631	604	501	630	589	491	618	576
90 / 32	515	593	578	481	572	545	459	579	535	420	532	486
<b>Cycle Time Freeze</b>	19	18	18	20	18	18	20	18	18	20	19	19
	20	18	18	22	19	20	24	20	21	24	20	21
	22	20	20	24	21	22	26	21	23	27	22	24
<b>Cycle Time Harvest</b>	4.9	4.1	4.4	4.3	3.8	3.9	4.2	3.7	3.8	3.3	3.2	3.2
	4.2	3.7	3.8	3.1	3.1	3.1	2.3	2.6	2.5	2.2	2.6	2.4
	3.8	3.4	3.5	3.2	3.0	2.9	2.1	2.4	2.2	2.0	2.2	2.0
<b>Pressure High Side</b>	225	229	202	243	229	214	248	230	217	253	234	221
	248	230	217	279	230	238	305	231	255	311	234	259
	276	239	237	305	245	257	332	244	275	357	255	293
<b>Pressure Suction</b>	42	35	33	44	36	34	45	36	35	47	37	36
	45	36	35	49	37	38	53	37	40.4	54	38	41
	51	38	39	55	40	42	59	40	44	64	43	48

NOTE: Total Cycle Time = Freeze + Harvest      Pressure data is recorded 5 minutes into the freeze cycle.



**PERFORMANCE DATA**

MODEL: KM-650M\_H

Supply Voltage: 208-230/60/1 (3 wire w/neutral for 115V)

Total Amperage (Compressor RLA):

Air: 6.6A (6A)

Water: 5.3A (5.0A)

Remote: 7.1A (5.6A) Ice Production per cycle: 13.5 lbs, 720 pcs

Water Consumption for MWH Condenser:

70/50 (2.1/1.0) 408 Gal/24hrs

90/70 (3.2/2.1) 741 Gal/24hrs

Ambient Temp (F°/C°)	70 / 21			80 / 27			90 / 32			100 / 38		
	Air	Water	Remote	Air	Water	Remote	Air	Water	Remote	Air	Water	Remote
<b>Kg=lbs x.454 Production 24 hours (lbs)</b>	50 / 10	680	615	572	676	601	566	675	597	555	651	583
	70 / 21	566	597	537	668	574	512	662	554	501	647	543
	90 / 32	526	626	556	490	523	467	598	506	426	540	462
<b>Cycle Time Freeze</b>	50 / 10	30	27	29	28	30	32	28	31	33	29	32
	70 / 21	32	28	31	35	33	37	31	34	38	31	35
	90 / 32	35	30	33	38	32	40	33	37	43	35	40
<b>Cycle Time Harvest</b>	50 / 10	4.6	4.7	4.6	4.3	4.0	3.9	4.1	3.8	3.1	3.4	3.0
	70 / 21	3.9	4.1	3.8	3.4	2.8	2.2	2.8	2.0	2.2	2.7	2.0
	90 / 32	3.6	3.7	3.6	3.0	3.1	3.0	2.1	2.5	2.0	2.1	2.0
<b>Pressure High Side</b>	50 / 10	225	231	214	241	229	246	231	233	249	235	235
	70 / 21	246	231	233	275	258	298	231	279	303	233	283
	90 / 32	270	238	254	295	275	320	240	298	341	249	315
<b>Pressure Suction</b>	50 / 10	53	50	51	54	53	55	51	53	56	51	54
	70 / 21	55	51	53	57	56	59	56	58	60	56	59
	90 / 32	58	53	56	61	54	63	56	61	67	57	64

NOTE: Total Cycle Time = Freeze + Harvest Pressure data is recorded 5 minutes into the freeze cycle.

**PERFORMANCE DATA**

MODEL: KM-650MAH-E

Total Amperage (Compressor RLA): Air: 6.8A (5.7A)

Supply Voltage: 220-240/50/1

Ice Production per cycle: 14 lbs, 720 pcs

Ambient Temp (F°/C°)	70 / 21	80 / 27	90 / 32	100 / 38
Water Temp	Air	Air	Air	Air
<b>Kg=lbs x.454</b>				
<b>Production</b>				
<b>24 hours</b>				
<b>(lbs)</b>				
	653	620	610	602
	610	554	507	495
	558	506	456	409
<b>Cycle Time</b>				
<b>Freeze</b>				
	29	31	32	32
	32	34	37	38
	35	38	40	43
<b>Cycle Time</b>				
<b>Harvest</b>				
	3.9	3.7	3.6	3.3
	3.6	3.2	2.9	2.9
	3.5	3.3	2.9	2.9
<b>Pressure</b>				
<b>High Side</b>				
	236	254	259	263
	259	290	315	321
	286	314	341	365
<b>Pressure</b>				
<b>Suction</b>				
	53	55	55	56
	55	58	60	61
	58	60	63	65

NOTE: Total Cycle Time = Freeze + Harvest

Pressure data is recorded 5 minutes into the freeze cycle.

**PERFORMANCE DATA**

MODEL: KMD-700M\_H

Supply Voltage: 208-230/60/1 (3wire w/neutral for 115V)

Total Amperage (Compressor RLA):

Air: 13.5A (10.2A)

Water: 12A (9.8A)

Remote: 13A (10A) Ice Production per cycle: 9.6 lbs, 624 pcs

Water Consumption for MWH Condenser:

70/50 (21/10) 403 Gal/24hrs

90/70 (32/21) 607 Gal/24hrs

Kg=lbs x.454 Production 24 hours (lbs)	70 / 21			80 / 27			90 / 32			100 / 38		
	Air	Water	Remote	Air	Water	Remote	Air	Water	Remote	Air	Water	Remote
Water Temp F°/C°												
50 / 10	696	701	730	661	681	719	650	675	715	641	665	690
70 / 21	650	675	715	589	640	696	539	611	679	526	601	662
90 / 32	593	634	655	536	597	614	483	569	605	432	530	538
<b>Cycle Time Freeze</b>	17 19 20 21	19 20 21	17 18 20 20	18 21 24	19 20 22	18 19 21	19 23 26	20 21 23	18 20 22	19 24 28	20 21 24	18 20 24
<b>Cycle Time Harvest</b>	3.3 2.9 2.0	2.2 2.1 2.0	3.3 2.9 2.0	3.0 2.4 2.0	2.2 2.1 2.0	3.0 2.4 2.0	2.9 2.0 2.0	2.1 2.0 2.0	2.9 2.0 2.0	2.5 2.0 2.0	2.1 2.0 2.0	2.5 2.0 2.0
<b>Pressure High Side</b>	250 273 293	275 276 284	215 222 236	268 304 316	276 277 289	221 232 248	273 330 346	276 278 288	222 240 256	273 334 360	280 280 298	226 244 270
<b>Pressure Suction</b>	45 48 51	40 42 49	35 36 39	47 52 54	41 44 53	36 38 41	48 56 58	42 46 54	36 40 43	48 56 60	45 48 62	37 41 45

Pressure data is recorded 5 minutes into the freeze cycle.

NOTE: Total Cycle Time = Freeze + Harvest

**PERFORMANCE DATA**

MODEL: KMS-750MLH & SRK-7H

Supply Voltage: 115/60/1 supplied by SRK through wiring harness

Total Amperage (Compressor RLA): 13A (7A)

Ice Production per cycle: 15 lbs, 832 pcs

Ambient Temp (F°/C°)		70 / 21	80/27	90/32	100/38	
<b>Kg=lbs x.454 Production 24 hours (lbs)</b>	Water Temp F°/C°	Low Side				Low Side
	50 / 10	770	754	749	706	
	70 / 21	749	722	700	684	
90 / 32	691	647	630	566		
<b>Cycle Time Freeze</b>	50 / 10	25	25	26	28	
	70 / 21	26	27	28	29	
	90 / 32	28	30	31	34	
<b>Cycle Time Harvest</b>	50 / 10	3	3	3	2	
	70 / 21	3	2	2	2	
	90 / 32	3	2	2	2	
<b>Pressure High Side</b>	50 / 10	222	229	231	235	
	70 / 21	231	243	253	257	
	90 / 32	247	261	270	286	
<b>Pressure Suction</b>	50 / 10	46	48	48	49	
	70 / 21	48	50	51	52	
	90 / 32	51	53	54	57	

NOTE: Total Cycle Time = Freeze + Harvest

Pressure data is recorded 5 minutes into the freeze cycle.

**PERFORMANCE DATA**

MODEL: KMS-822MLH & SRK-10H

Supply Voltage: 115/60/1 supplied by SRK through wiring harness

Total Amperage (Compressor RLA): 11.5A (7.7A)

Ice Production per cycle: 13.6 lbs, 624 pcs

Ambient Temp (F°/C°)		70 / 21	80 / 27	90 / 32	100 / 38
Kg=lbs x.454 Production 24 hours (lbs)	Water Temp F°/C°	Low Side			
		50 / 10	839	824	820
	70 / 21	820	795	774	760
	90 / 32	769	730	714	659
Cycle Time Freeze	50 / 10	20	21	21	21
	70 / 21	21	22	23	24
	90 / 32	23	24	25	27
Cycle Time Harvest	50 / 10	3.9	3.6	3.4	2.9
	70 / 21	3.4	2.8	2.2	2.2
	90 / 32	3.2	2.8	2.2	2.1
Pressure High Side	50 / 10	179	189	192	196
	70 / 21	192	209	223	228
	90 / 32	211	229	243	262
Pressure Suction	50 / 10	36	37	37	40
	70 / 21	37	39	41	43
	90 / 32	43	47	48	54

NOTE: Total Cycle Time = Freeze + Harvest

Pressure data is recorded 5 minutes into the freeze cycle.

## PERFORMANCE DATA

MODEL: KMS-830MLH & SRK-8H & H3

Supply Voltage: 115/60/1 supplied by SRK through wiring harness

Total Amperage (Compressor RLA): 9.1A (7.7A) 3 Ph: 7.5A (5.7A)

Ice per cycle: 13.6 lbs, 680 pcs, 3 Ph: 12.7 lbs, 680 pcs

Water Temp F°/C°	70 / 21			80/27			90/32			100/38		
	Low Side	3 Phase	Low Side	3 Phase	Low Side	3 Phase	Low Side	3 Phase	Low Side	3 Phase	Low Side	3 Phase
<b>Kg=lbs x.454</b>												
<b>Production</b>												
<b>24 hours</b>												
<b>(lbs)</b>	820	791	793	768	785	776	751	776	785	751	776	748
	785	761	739	722	700	689	722	689	700	722	689	677
	737	711	691	667	652	607	635	607	652	635	607	585
<b>Cycle Time</b>												
<b>Freeze</b>	20	20	21	21	21	22	21	22	21	21	22	22
	21	21	23	23	24	25	24	25	24	24	25	25
	24	23	25	25	27	29	27	29	27	27	29	29
<b>Cycle Time</b>												
<b>Harvest</b>	4.3	4.5	3.8	3.9	3.7	3.0	3.8	3.0	3.7	3.8	3.0	3.0
	3.7	3.8	2.8	2.8	2.1	2.1	2.1	2.1	2.1	2.1	2.1	2.1
	3.5	3.5	3.0	3.0	2.1	2.1	2.1	2.1	2.1	2.1	2.1	2.1
<b>Pressure</b>												
<b>High Side</b>	200	182	211	197	215	221	202	221	215	202	221	206
	215	202	234	228	250	256	250	256	250	250	256	256
	239	227	260	252	276	300	275	300	276	275	300	298
<b>Pressure</b>												
<b>Suction</b>	41	36	42	38	42	44	38	44	42	38	44	39
	42	38	43	41	44	45	43	45	44	43	45	44
	46	41	49	44	49	54	46	54	49	46	54	49

NOTE: Total Cycle Time = Freeze + Harvest

Pressure data is recorded 5 minutes into the freeze cycle.

**PERFORMANCE DATA**

MODEL: KMD-850M\_H

Supply Voltage: 208-230/60/1 (3wire w/neutral for 115V)

Total Amperage (Compressor RLA):

Air: 9.8A (6.4A)

Water: 8.3A (6.2A)

Remote: 9.8A (6.7A) Ice Production per cycle: 11.8 lbs, 624 pcs

Water Consumption for MWH Condenser:

70/50 (21/10) 565 Gal/24hrs

90/70 (32/21) 1035 Gal/24hrs

Ambient Temp (F°/C°)	70 / 21			80 / 27			90 / 32			100 / 38			
	Water Temp F°/C°	Air	Water	Remote	Air	Water	Remote	Air	Water	Remote	Air	Water	Remote
<b>Kg=lbs x.454 Production 24 hours (lbs)</b>	50 / 10	786	836	833	753	831	803	743	830	793	732	809	782
	70 / 21	743	830	793	686	822	741	639	815	698	625	802	685
	90 / 32	685	786	738	629	759	686	580	759	641	526	708	589
<b>Cycle Time Freeze</b>	50 / 10	19	18	18	20	18	18	21	18	19	21	19	19
	70 / 21	21	18	19	23	19	20	25	20	22	26	20	22
	90 / 32	23	20	21	26	21	23	27	21	24	30	23	26
<b>Cycle Time Harvest</b>	50 / 10	3.2	3.0	2.9	2.9	2.8	2.7	2.8	2.7	2.6	2.5	2.4	2.4
	70 / 21	2.8	2.7	2.6	2.4	2.4	2.3	2.0	2.1	2.0	2.0	2.1	2.0
	90 / 32	2.7	2.6	2.5	2.5	2.4	2.4	2.0	2.0	2.0	2.0	2.0	2.0
<b>Pressure High Side</b>	50 / 10	248	228	205	265	229	219	270	229	223	276	233	229
	70 / 21	270	229	223	300	231	248	324	232	268	331	234	274
	90 / 32	300	237	250	330	241	275	355	241	296	383	250	321
<b>Pressure Suction</b>	50 / 10	43	39	38	46	39	40	47	39	41	49	41	43
	70 / 21	47	39	41	51	40	44	55	40	47	57	41	49
	90 / 32	53	43	47	59	46	53	63	45	55	70	50	62

NOTE: Total Cycle Time = Freeze + Harvest

Pressure data is recorded 5 minutes into the freeze cycle.

**PERFORMANCE DATA**

MODEL: KM-900M\_H

Supply Voltage: 208-230/60/1 (3wire w/neutral for 115V)

Total Amperage (Compressor RLA): Air: 11A (10.2A) Water: 10.2A (9.7A) Remote: 12.5A (10.0A) Ice Production per cycle: 14.3 lbs, 720 pcs

Water Consumption for MWH Condenser: 70/50 (21/10) 491 Gal/24hrs 90/70 (32/21) 916 Gal/24hrs

Ambient Temp (F°/C°)	70 / 21			80 / 27			90 / 32			100 / 38			
	Water Temp F°/C°	Air	Water	Remote	Air	Water	Remote	Air	Water	Remote	Air	Water	Remote
<b>Kg=lbs x.454 Production 24 hours (lbs)</b>	50 / 10	838	846	835	812	836	824	804	833	821	795	814	808
	70 / 21	804	833	821	759	815	802	721	801	786	710	788	776
	90 / 32	759	787	786	715	754	758	676	745	745	634	694	708
<b>Cycle Time Freeze</b>	50 / 10	21	21	21	22	21	22	22	22	22	23	22	22
	70 / 21	22	22	22	24	22	23	26	23	24	27	23	24
	90 / 32	25	23	24	27	25	25	29	25	26	31	27	28
<b>Cycle Time Harvest</b>	50 / 10	4.5	3.9	4.5	4.1	3.6	4.1	4.0	3.5	3.9	3.9	3.5	3.2
	70 / 21	3.9	3.5	3.9	3.1	2.9	3.1	2.5	2.4	2.5	2.4	2.4	2.4
	90 / 32	3.5	3.2	3.5	3.0	2.8	3.0	2.2	2.2	2.2	2.0	2.0	2.0
<b>Pressure High Side</b>	50 / 10	245	280	220	262	280	230	267	280	233	272	284	239
	70 / 21	267	280	233	296	280	251	320	280	265	327	284	270
	90 / 32	296	288	255	324	292	274	349	290	288	375	300	310
<b>Pressure Suction</b>	50 / 10	33	36	32	35	38	34	36	38	34	37	38	35
	70 / 21	36	38	34	39	41	37	42	43	40	43	43	41
	90 / 32	40	39	37	43	41	40	46	44	43	50	44	45

NOTE: Total Cycle Time = Freeze + Harvest Pressure data is recorded 5 minutes into the freeze cycle.



**PERFORMANCE DATA**

MODEL: KM-900MRH3

Supply Voltage: 208-230/60/3

Total Amperage (Compressor RLA): Remote: 6.5A (4.7A)

Ice Production per cycle: 14.3 lbs, 720 pcs

Ambient Temp (F°/C°)	70 / 21	80 / 27	90 / 32	100 / 38
Water Temp				
F°/C°	Remote	Remote	Remote	Remote
<b>Kg=lbs x.454</b>				
<b>Production</b>	842	830	826	811
<b>24 hours</b>	826	806	789	777
<b>(lbs)</b>	784	753	739	694
<b>Cycle Time</b>	22	22	23	23
<b>Freeze</b>	23	23	24	24
	24	26	26	28
<b>Cycle Time</b>	4.5	4.1	3.9	3.2
<b>Harvest</b>	3.9	3.1	2.5	2.4
	3.5	3.0	2.2	2.0
<b>Pressure</b>	225	233	235	241
<b>High Side</b>	235	249	260	265
	254	270	281	300
<b>Pressure</b>	30	32	32	33
<b>Suction</b>	32	35	38	39
	35	38	41	44

NOTE: Total Cycle Time = Freeze + Harvest

Pressure data is recorded 5 minutes into the freeze cycle.

**PERFORMANCE DATA**

MODEL: KM-900MAH-50

Supply Voltage: 220-240/50/1

Total Amperage (Compressor RLA): Air: 10A (9.0A)

Ice Production per cycle: 14.3 lbs, 720 pcs

Ambient Temp (F°/C°)		70 / 21	80 / 27	90 / 32	100 / 38
<b>Kg=lbs x.454 Production 24 hours (lbs)</b>	Water Temp F°/C°	Air	Air	Air	Air
	50 / 10	839	810	801	785
	70 / 21	801	751	710	694
	90 / 32	738	681	641	578
<b>Cycle Time Freeze</b>	50 / 10	23	24	25	26
	70 / 21	25	27	29	30
	90 / 32	28	31	33	36
<b>Cycle Time Harvest</b>	50 / 10	3.8	3.4	3.2	2.8
	70 / 21	3.2	2.6	2.0	2.8
	90 / 32	3.1	2.7	2.9	2.8
<b>Pressure High Side</b>	50 / 10	240	256	261	266
	70 / 21	261	288	310	317
	90 / 32	289	316	339	365
<b>Pressure Suction</b>	50 / 10	40	42	42	43
	70 / 21	42	45	48	49
	90 / 32	46	49	52	55

NOTE: Total Cycle Time = Freeze + Harvest

Pressure data is recorded 5 minutes into the freeze cycle.

**PERFORMANCE DATA**

MODEL: KMD-900M\_H

Supply Voltage: 208-230/60/1 (3 wire w/neutral for 115V)

Total Amperage (Compressor RLA): Air: 15A (11.2A) Water: 14A (11.2A) Remote: 14A (11.2A) Ice Production per cycle: 9.6 lbs, 624 pcs

Water Consumption for MWH Condenser: 70/50 (21/10) 526 Gal/24hrs 90/70 (32/21) 831 Gal/24hrs

Ambient Temp (F°/C°)	70 / 21			80 / 27			90 / 32			100 / 38		
	Air	Water	Remote	Air	Water	Remote	Air	Water	Remote	Air	Water	Remote
<b>Kg=lbs x-.454 Production 24 hours (lbs)</b>	50 / 10	886	906	850	865	885	842	859	878	817	848	857
	70 / 21	842	859	878	799	823	842	793	812	743	782	795
	90 / 32	767	816	814	706	777	763	676	747	596	705	669
<b>Cycle Time Freeze</b>	50 / 10	13	14	13	14	13	14	15	13	14	15	14
	70 / 21	14	15	13	15	14	17	16	15	17	16	15
	90 / 32	15	16	14	17	16	18	17	16	20	18	17
<b>Cycle Time Harvest</b>	50 / 10	3.5	3.2	2.7	3.2	2.6	3.1	3.0	2.5	2.6	2.7	2.3
	70 / 21	3.1	3.0	2.5	2.5	2.2	2.0	2.4	2.0	2.0	2.4	2.0
	90 / 32	2.0	2.5	2.0	2.0	2.4	2.0	2.0	2.3	2.0	2.2	2.0
<b>Pressure High Side</b>	50 / 10	210	275	210	276	219	233	276	222	241	280	226
	70 / 21	233	276	222	264	237	290	278	250	299	281	255
	90 / 32	268	285	240	301	290	326	289	270	360	300	288
<b>Pressure Suction</b>	50 / 10	27	32	26	31	28	32	33	28	33	36	30
	70 / 21	32	33	28	39	34	45	35	34	47	37	35
	90 / 32	39	39	34	46	43	52	43	40	58	50	46

NOTE: Total Cycle Time = Freeze + Harvest Pressure data is recorded 5 minutes into the freeze cycle.

**PERFORMANCE DATA**

MODEL: KM-901M\_H

Supply Voltage: 208-230/60/1

Total Amperage (Compressor RLA):

Air: 11.4A (9.9A) Water: 8.7A (8.1A) Remote: 11.6A (9.4A) Ice Production per cycle: 13.6 lbs, 720 pcs

Water Consumption for MWH Condenser:

70/50 (21/10) 631 Gal/24hrs 90/70 (32/21) 1162 Gal/24hrs

Kg=lbs x.454 Production 24 hours (lbs)	70 / 21			80 / 27			90 / 32			100 / 38			
	Ambient Temp (F°/C°)	Water Temp F°/C°	Water	Remote	Air	Water	Remote	Air	Water	Remote	Air	Water	Remote
	50 / 10	874	912	889	842	895	866	832	889	859	826	878	843
	70 / 21	832	889	859	778	860	818	732	835	785	721	825	771
	90 / 32	785	849	803	736	815	755	687	791	724	646	751	668
Cycle Time Freeze	50 / 10	19	18	18	20	19	19	20	19	20	21	19	20
	70 / 21	20	19	20	22	19	21	24	20	22	24	20	23
	90 / 32	22	20	21	24	21	23	26	21	24	27	22	26
Cycle Time Harvest	50 / 10	4.3	4.1	4.3	4.0	3.9	4.0	3.9	3.8	3.9	3.3	3.4	3.4
	70 / 21	3.9	3.8	3.9	3.3	3.4	3.4	2.8	3.1	2.9	2.7	3.0	2.8
	90 / 32	3.6	3.6	3.6	3.1	3.3	3.2	2.6	2.9	2.7	2.4	2.7	2.4
Pressure High Side	50 / 10	219	227	208	234	229	224	238	230	229	242	234	232
	70 / 21	238	230	229	263	233	256	284	236	279	289	239	284
	90 / 32	261	240	252	284	247	277	306	249	301	327	260	322
Pressure Suction	50 / 10	35	33	35	36	34	37	37	34	37	38	36	38
	70 / 21	37	34	37	39	36	40	41	37	43	42	38	44
	90 / 32	41	38	41	44	40	45	46	41	47	50	45	51

NOTE: Total Cycle Time = Freeze + Harvest Pressure data is recorded 5 minutes into the freeze cycle.

**PERFORMANCE DATA**

MODEL: KM-901MRH3

Supply Voltage: 208-230/60/3

Total Amperage (Compressor RLA): Remote: 7A (5.9A)

Ice Production per cycle: 14.2 lbs, 720 pcs

Ambient Temp (F°/C°)		70 / 21	80 / 27	90 / 32	100 / 38
Kg=lbs x.454 Production 24 hours (lbs)	Water Temp F°/C°	Remote	Remote	Remote	Remote
		50 / 10	899	880	874
	70 / 21	874	842	815	800
	90 / 32	817	772	749	689
Cycle Time Freeze	50 / 10	19	20	20	20
	70 / 21	20	21	22	23
	90 / 32	21	23	24	26
Cycle Time Harvest	50 / 10	4.4	4.0	3.9	3.4
	70 / 21	3.9	3.3	2.8	2.7
	90 / 32	3.6	3.2	2.6	2.4
Pressure High Side	50 / 10	206	220	225	229
	70 / 21	225	249	270	275
	90 / 32	248	272	293	315
Pressure Suction	50 / 10	36	37	38	39
	70 / 21	38	40	42	43
	90 / 32	41	44	46	49

NOTE: Total Cycle Time = Freeze + Harvest  
Pressure data is recorded 5 minutes into the freeze cycle.

**PERFORMANCE DATA**

MODEL: KMD-901M\_H

Supply Voltage: 208-230/60/1 (3wire w/neutral for 115V)

Total Amperage (Compressor RLA):

Air: 10.8A (8.4A)      Water: 7.8A (6.6A)

Remote: 10A (7.9A)      Ice Production per cycle: 12 lbs, 624 pcs

Water Consumption for MWH Condenser:

70/50 (21/10) 593 Gal/24hrs

90/70 (32/21) 1088 Gal/24hrs

	70 / 21			80 / 27			90 / 32			100 / 38		
	Air	Water	Remote	Air	Water	Remote	Air	Water	Remote	Air	Water	Remote
<b>kg=lbs x.454 Production 24 hours (lbs)</b>	Water Temp F°/C°											
	50 / 10	890	876	848	870	875	832	864	874	843	852	805
	70 / 21	864	874	827	830	872	798	801	870	784	856	759
	90 / 32	803	831	768	754	805	723	730	812	665	759	641
<b>Cycle Time Freeze</b>	50 / 10	16	17	17	16	17	18	17	17	17	18	19
	70 / 21	17	17	18	18	18	20	19	18	19	19	21
	90 / 32	18	18	20	20	19	22	23	20	23	21	25
<b>Cycle Time Harvest</b>	50 / 10	3.3	3.3	3.5	3.0	3.1	3.1	3.0	3.0	2.5	2.7	2.6
	70 / 21	3.0	3.0	3.1	2.4	2.7	2.5	2.0	2.4	2.0	2.3	2.0
	90 / 32	2.8	2.8	2.9	2.5	2.5	2.6	2.0	2.2	2.0	2.0	2.0
<b>Pressure High Side</b>	50 / 10	231	232	210	246	233	223	251	233	258	237	231
	70 / 21	251	233	227	276	234	250	298	235	306	237	274
	90 / 32	281	241	248	309	245	270	330	245	360	254	309
<b>Pressure Suction</b>	50 / 10	36	38	36	38	38	38	39	39	41	40	40
	70 / 21	39	39	38	43	39	41	46	40	48	41	45
	90 / 32	45	41	43	51	43	47	53	44	60	57	55

NOTE: Total Cycle Time = Freeze + Harvest      Pressure data is recorded 5 minutes into the freeze cycle.

**PERFORMANCE DATA**

MODEL: KMS-1122MLH & SRK-8H & H3

Supply Voltage: 115/60/1 supplied by SRK through wiring harness

Total Amperage (Compressor RLA): 11.2A (7.7A) 3 Ph: 10.5A (5.7A)

Ice Production per cycle: 17 lbs, 880 pcs

Water Temp F°/C°	70 / 21			80 / 27			90 / 32			100 / 38		
	Low Side	3 Phase		Low Side	3 Phase		Low Side	3 Phase		Low Side	3 Phase	
<b>Kg=lbs x.454</b>												
<b>Production</b>												
<b>24 hours</b>	1100	1120	1074	1066	1093	1066	1085	1085	1066	1085	1046	1064
<b>(lbs)</b>	1066	1085	1022	999	1039	985	967	1000	982	1000	967	982
	90 / 32	1016	943		985	910		923	852		841	852
<b>Cycle Time</b>	19	19	20	20	20	20	20	20	20	20	21	21
<b>Freeze</b>	20	20	22	22	22	22	23	23	23	23	23	23
	22	22	24	24	24	24	25	25	25	25	27	27
<b>Cycle Time</b>	3.5	3.5	3.2	3.5	3.2	3.2	3.1	3.1	3.1	2.7	2.7	2.7
<b>Harvest</b>	3.1	3.1	2.5	3.1	2.5	2.5	2.1	2.1	2.1	2.1	2.1	2.1
	3.0	3.0	2.7	3.0	2.7	2.7	2.1	2.1	2.1	2.1	2.1	2.1
<b>Pressure</b>	178	170	190	193	184	193	188	188	198	192	198	192
<b>High Side</b>	193	188	213	213	213	230	233	233	235	238	235	238
	216	212	237	235	235	253	256	256	275	277	275	277
<b>Pressure</b>	42	40	43	42	42	43	42	42	46	44	46	44
<b>Suction</b>	43	42	45	45	45	47	47	47	49	48	49	48
	49	47	53	51	51	54	53	53	60	59	60	59

NOTE: Total Cycle Time = Freeze + Harvest

Pressure data is recorded 5 minutes into the freeze cycle.

**PERFORMANCE DATA**

MODEL: KMS-1230MLH & SRK-13H

Supply Voltage: 115/60/1 supplied by SRK through wiring harness

Total Amperage (Compressor RLA): 15A (10A)

Ice Production per cycle: 24 lbs, 12488 pcs

Ambient Temp (F°/C°)		70 / 21	80/27	90/32	100/38
Kg=lbs x .454 Production 24 hours (lbs)	Water Temp F°/C°	Low Side	Low Side	Low Side	Low Side
		50 / 10	1115	1117	1118
	70 / 21	1118	1122	1126	1102
	90 / 32	1042	1001	1022	927
Cycle Time Freeze	50 / 10	26	26	26	27
	70 / 21	26	26	27	27
	90 / 32	28	29	29	31
Cycle Time Harvest	50 / 10	6	5	5	4
	70 / 21	5	4	3	3
	90 / 32	5	4	3	3
Pressure High Side	50 / 10	230	231	231	240
	70 / 21	231	233	235	240
	90 / 32	249	260	258	280
Pressure Suction	50 / 10	39	40	40	40
	70 / 21	40	41	42	42
	90 / 32	41	43	44	45

NOTE: Total Cycle Time = Freeze + Harvest

Pressure data is recorded 5 minutes into the freeze cycle.



**PERFORMANCE DATA**

MODEL: KM-1300M\_H

Supply Voltage: 208-230/60/1 (3wire w/neutral for 115V)  
 Total Amperage (Compressor RLA): Air: 13.2A (9.0A) Water: 11.5A (9.5A) Remote: 13.5A (8.0A) Ice Production per cycle: 28.6 lbs, 1440 pcs  
 Water Consumption for MWH Condenser: 70/50 (21/10) 824 Gal/24hrs 90/70 (32/21) 1330 Gal/24hrs

Ambient Temp (F°/C°)	70 / 21			80 / 27			90 / 32			100 / 38			
	Water Temp F°/C°	Air	Water	Remote	Air	Water	Remote	Air	Water	Remote	Air	Water	Remote
<b>Kg=lbs x.454 Production 24 hours (lbs)</b>	50 / 10	1289	1291	1322	1238	1276	1291	1222	1271	1281	1198	1238	1252
	70 / 21	1222	1271	1281	1133	1244	1228	1059	1222	1183	1034	1200	1159
	90 / 32	1120	1193	1193	1026	1138	1121	952	1126	1082	853	1038	989
<b>Cycle Time Freeze</b>	50 / 10	28	29	27	29	30	28	30	30	29	31	30	30
	70 / 21	30	30	29	33	31	31	35	32	32	36	32	33
	90 / 32	33	32	31	37	33	34	39	34	35	43	36	38
<b>Cycle Time Harvest</b>	50 / 10	4.6	4.0	4.4	4.2	3.7	4.0	4.0	3.6	3.9	3.3	3.6	3.0
	70 / 21	4.0	3.6	3.9	3.3	3.0	3.2	2.6	2.6	2.6	2.5	2.6	2.5
	90 / 32	3.6	3.3	3.5	2.5	2.9	3.0	2.3	2.4	2.3	2.0	2.2	2.0
<b>Pressure High Side</b>	50 / 10	247	279	227	264	279	236	269	280	239	272	285	242
	70 / 21	269	280	239	297	281	255	321	282	268	326	286	272
	90 / 32	293	291	255	318	298	271	344	297	285	365	311	300
<b>Pressure Suction</b>	50 / 10	49	47	47	50	48	48	50	48	48	50	48	48
	70 / 21	50	48	48	52	49	49	53	50	50	53	50	50
	90 / 32	52	49	49	53	50	51	55	51	52	56	52	53

NOTE: Total Cycle Time = Freeze + Harvest  
 Pressure data is recorded 5 minutes into the freeze cycle.

**PERFORMANCE DATA**

MODEL: KM-1300S\_H

Supply Voltage: 208-230/60/1 (3 wire w/neutral for 115V)  
 Total Amperage (Compressor RLA): Air: 12.6A (10.2A) Water: 9.7A (9.7A) Remote: 14.5A (10A) Ice Production per cycle: 30.1 lbs, 1440 pcs  
 Water Consumption for SWH Condenser: 70/50 (2.1/1.0) 668 Gal/24hrs 90/70 (32/21) 920 Gal/24hrs

Ambient Temp (F°/C°)	70 / 21			80 / 27			90 / 32			100 / 38		
	Air	Water	Remote	Air	Water	Remote	Air	Water	Remote	Air	Water	Remote
<b>Kg=lbs x.454 Production 24 hours (lbs)</b>	1283 50 / 10 1242 70 / 21 1135 90 / 32	1284 1282 1208	1296 1257 1173	1252 1188 1053	1283 1280 1166	1266 1206 1105	1242 1143 1017	1282 1278 1180	1257 1163 1068	1203 1114 902	1243 1255 1089	1230 1141 980
<b>Cycle Time Freeze</b>	30 32 33 36 35	32 33 35	29 30 33	32 35 39	32 33 36	30 31 36	32 37 41	33 34 37	30 32 36	33 38 44	33 35 39	31 33 40
<b>Cycle Time Harvest</b>	4.5 70 / 21 3.8 90 / 32	4.3 3.7 3.4	5.0 4.2 3.8	4.0 2.9 3.0	3.9 2.9 2.9	4.4 3.1 3.2	3.8 2.2 2.1	3.7 2.3 2.1	4.2 2.2 2.1	3.1 2.2 2.0	3.8 2.3 2.0	3.3 2.2 2.0
<b>Pressure High Side</b>	255 70 / 21 273 90 / 32	275 278 288	220 232 247	268 296 318	277 282 295	229 247 262	273 315 338	278 285 297	232 260 276	277 320 360	282 288 308	235 264 290
<b>Pressure Suction</b>	45 70 / 21 47 90 / 32	47 48 49	45 46 49	46 49 51	47 48 49	46 48 51	47 51 53	48 49 50	46 50 53	47 51 55	48 49 51	47 51 55

NOTE: Total Cycle Time = Freeze + Harvest  
 Pressure data is recorded 5 minutes into the freeze cycle.

**PERFORMANCE DATA**

MODEL: KM-1300S\_H3

Supply Voltage: 208-230/60/3

Total Amperage (Compressor RLA): Air: 7.8A (6.1A) Water: 6.9A (5.8A) Remote: 10.8A (7A) Ice Production per cycle: 30.1 lbs, 1440 pcs

Water Consumption for SWH3 Condenser: 70/50 (21/10) 640 Gal/24hrs 90/70 (32/21) 927 Gal/24hrs

Ambient Temp (F°/C°)	70 / 21			80 / 27			90 / 32			100 / 38			
	Water Temp F°/C°	Air	Water	Remote	Air	Water	Remote	Air	Water	Remote	Air	Water	Remote
<b>Kg=lbs x.454 Production 24 hours (lbs)</b>	50 / 10	1320	1254	1308	1278	1261	1299	1265	1264	1296	1230	1220	1252
	70 / 21	1265	1264	1296	1192	1276	1279	1132	1287	1266	1102	1263	1238
	90 / 32	1153	1191	1203	1060	1157	1145	1006	1186	1148	890	1093	1039
<b>Cycle Time Freeze</b>	50 / 10	30	30	30	32	31	31	32	31	31	33	32	32
	70 / 21	32	31	31	35	32	32	37	33	33	38	33	34
	90 / 32	36	33	33	39	34	35	41	35	36	45	37	39
<b>Cycle Time Harvest</b>	50 / 10	4.0	4.2	4.8	3.6	3.8	4.2	3.4	3.6	4.0	2.8	3.0	3.2
	70 / 21	3.4	3.6	4.0	2.7	2.8	3.0	2.1	2.2	2.2	2.1	2.2	2.2
	90 / 32	3.2	3.3	3.7	2.8	2.9	3.1	2.0	2.1	2.1	2.0	2.0	2.0
<b>Pressure High Side</b>	50 / 10	255	270	230	270	273	239	274	274	242	277	277	246
	70 / 21	274	274	242	299	280	257	320	285	270	325	287	274
	90 / 32	296	284	259	318	291	275	341	295	288	360	305	305
<b>Pressure Suction</b>	50 / 10	47	48	50	48	49	51	48	49	51	49	49	52
	70 / 21	48	49	51	50	50	52	52	51	53	52	51	54
	90 / 32	50	50	53	52	51	55	54	52	56	55	53	58

NOTE: Total Cycle Time = Freeze + Harvest Pressure data is recorded 5 minutes into the freeze cycle.

**PERFORMANCE DATA**

MODEL: KM-1300SAHE

Supply Voltage: 220-240/50/1

Total Amperage (Compressor RLA): Air: 11.5A (9.5A)

Ice Production per cycle: 30.1 lbs, 1440 pcs

Ambient Temp (F°/C°)	70 / 21	80 / 27	90 / 32	100 / 38
<b>Water Temp</b>	Air	Air	Air	Air
<b>Kg=lbs x.454</b>				
<b>Production</b>				
<b>24 hours</b>	1200	1129	1106	1086
<b>(lbs)</b>	1106	983	880	853
	988	871	763	655
<b>Cycle Time</b>				
<b>Freeze</b>	50 / 10 70 / 21 90 / 32	28 33 40	29 37 43	31 38 49
<b>Cycle Time</b>				
<b>Harvest</b>	50 / 10 70 / 21 90 / 32	4 4 4	4 3.5 4	4 4 3.5
<b>Pressure</b>				
<b>High Side</b>	240 268 287	261 304 313	268 335 348	265 338 360
<b>Pressure</b>				
<b>Suction</b>	50 / 10 70 / 21 90 / 32	51 53 56	51 55 58	52 56 60

NOTE: Total Cycle Time = Freeze + Harvest

Pressure data is recorded 5 minutes into the freeze cycle.

**PERFORMANCE DATA**

MODEL: KM-1301S\_H

Supply Voltage: 208-230/60/1 (3 wire w/neutral for 115V)

Total Amperage (Compressor RLA):

Air: 12.4A (10A) Water: 8.2A (8.2A) Remote: 13.5A (9.3A) Ice Production per cycle: 31 lbs, 1440 pcs

Water Consumption for SWH Condenser:

70/50 (21./10) 861 Gal/24hrs 90/70 (32/21) 1561 Gal/24hrs

Ambient Temp (F°/C°)	70 / 21			80 / 27			90 / 32			100 / 38			
	Water Temp F°/C°	Air	Water	Remote	Air	Water	Remote	Air	Water	Remote	Air	Water	Remote
<b>Kg=lbs x.454 Production 24 hours (lbs)</b>	50 / 10	1329	1318	1353	1292	1319	1324	1281	1319	1315	1253	1281	1281
	70 / 21	1281	1319	1315	1217	1321	1264	1164	1323	1222	1140	1301	1196
	90 / 32	1188	1249	1219	1109	1211	1144	1060	1228	1110	965	1141	1008
<b>Cycle Time Freeze</b>	50 / 10	31	31	31	32	31	32	32	31	32	33	32	33
	70 / 21	32	31	32	34	32	33	35	32	35	36	33	35
	90 / 32	35	33	34	37	34	36	38	34	37	41	36	40
<b>Cycle Time Harvest</b>	50 / 10	4.7	4.5	4.1	4.1	4.0	3.7	3.9	3.9	3.6	3.1	3.2	3.0
	70 / 21	3.9	3.9	3.6	2.9	3.1	2.9	2.1	2.4	2.3	2.1	2.4	2.3
	90 / 32	3.7	3.5	3.3	3.1	3.0	2.9	2.2	2.2	2.2	2.1	2.1	2.1
<b>Pressure High Side</b>	50 / 10	255	235	211	269	236	222	273	236	226	278	241	230
	70 / 21	273	236	226	297	237	246	317	238	262	323	241	267
	90 / 32	298	246	246	321	253	265	342	252	282	365	264	301
<b>Pressure Suction</b>	50 / 10	50	50	50	50	50	50	50	50	51	52	51	52
	70 / 21	50	50	51	50	49	51	50	49	52	51	50	53
	90 / 32	53	52	53	55	52	55	55	52	56	59	54	59

NOTE: Total Cycle Time = Freeze + Harvest Pressure data is recorded 5 minutes into the freeze cycle.

**PERFORMANCE DATA**

MODEL: KM-1301SAH-E

Supply Voltage: 220-240/50/1

Total Amperage (Compressor RLA): Air: 11.5A (10.3A)

Ice Production per cycle: 30.1 lbs, 1440 pcs

Kg=lbs x.454 Production 24 hours (lbs)	70 / 21		80 / 27		90 / 32		100 / 38	
	Ambient Temp (F°/C°)	Water Temp F°/C°	Air	Air	Air	Air	Air	Air
Cycle Time Freeze	50 / 10	34	1089	1082	1082	1048	1048	1048
	70 / 21	35	1039	1004	1004	979	979	979
	90 / 32	39	924	897	897	799	799	799
Cycle Time Harvest	50 / 10	4.8	35	35	35	37	37	37
	70 / 21	4.0	38	38	38	40	40	40
	90 / 32	3.7	43	43	44	48	48	48
Pressure High Side	50 / 10	275	4.2	4.2	4.0	3.1	3.1	3.1
	70 / 21	293	3.9	3.9	2.1	2.1	2.1	2.1
	90 / 32	316	3.2	3.2	2.1	2.1	2.1	2.1
Pressure Suction	50 / 10	57	289	293	293	297	297	297
	70 / 21	58	318	318	338	343	343	343
	90 / 32	61	338	338	360	380	380	380

NOTE: Total Cycle Time = Freeze + Harvest

Pressure data is recorded 5 minutes into the freeze cycle.

**PERFORMANCE DATA**

MODEL: KM-1301S\_H3

Supply Voltage: 208-230/60/3

Total Amperage (Compressor RLA):

Air: 9.5A (7.1A)    Water: 6.1A (6.1A)    Remote: 10.7A (6.2A)    Ice Production per cycle: 32.2 lbs, 1440 pcs

Water Consumption for SWH3 Condenser:    70/50 (21/10)    857 Gal/24hrs    80 / 27    90/70 (32/21)    1547 Gal/24hrs

Ambient Temp (F°/C°)	70 / 21			80 / 27			90 / 32			100 / 38			
	Water Temp F°/C°	Air	Water	Remote	Air	Water	Remote	Air	Water	Remote	Air	Water	Remote
<b>Kg=lbs x.454 Production 24 hours (lbs)</b>	50 / 10	1298	1333	1339	1267	1326	1307	1257	1323	1297	1225	1286	1266
	70 / 21	1257	1323	1297	1204	1311	1243	1159	1300	1197	1133	1277	1171
	90 / 32	1162	1246	1203	1086	1198	1127	1049	1201	1088	947	1110	988
<b>Cycle Time Freeze</b>	50 / 10	32	30	31	33	31	32	33	31	32	34	31	33
	70 / 21	33	31	32	35	32	34	36	32	35	37	33	36
	90 / 32	36	32	35	39	33	37	40	34	39	43	35	42
<b>Cycle Time Harvest</b>	50 / 10	4.2	4.5	3.9	3.8	4.0	3.5	3.6	3.8	3.4	2.9	3.1	2.9
	70 / 21	3.6	3.8	3.4	2.8	3.0	2.8	2.1	2.4	2.2	2.1	2.3	2.2
	90 / 32	3.4	3.5	3.2	2.9	3.0	2.8	2.1	2.2	2.1	2.1	2.1	2.1
<b>Pressure High Side</b>	50 / 10	254	237	214	268	238	224	272	238	228	276	244	234
	70 / 21	272	238	228	295	239	246	315	240	261	321	244	267
	90 / 32	296	249	252	319	256	273	339	255	287	361	269	311
<b>Pressure Suction</b>	50 / 10	48	50	50	49	50	50	49	50	51	50	51	52
	70 / 21	49	50	51	50	49	51	51	49	52	52	50	53
	90 / 32	52	52	54	54	53	56	55	52	56	58	55	60

NOTE: Total Cycle Time = Freeze + Harvest      Pressure data is recorded 5 minutes into the freeze cycle.

**PERFORMANCE DATA**

MODEL: KM-1340M\_H

Supply Voltage: 208-230/60/1 (3wire w/neutral for 115V)

Total Amperage (Compressor RLA): Air: 9.7A (8.2A) Water: 9.2A (8.2A) Remote: 9.5A (8A) Ice Production per cycle: 28.1 lbs, 1440 pcs

Water Consumption for MWH Condenser: 70/50 (21/10) 824 Gal/24hrs 90/70 (32/21) 1430 Gal/24hrs

Ambient Temp (F°/C°)	70 / 21			80 / 27			90 / 32			100 / 38			
	Water Temp F°/C°	Air	Water	Remote	Air	Water	Remote	Air	Water	Remote	Air	Water	Remote
<b>Kg= lbs x .454 Production 24 hours (lbs)</b>	50 / 10 70 / 21 90 / 32	1325 1278 1200	1382 1366 1284	1401 1357 1274	1289 1218 1130	1370 1344 1230	1367 1299 1204	1278 1167 1081	1366 1327 1224	1357 1251 1159	1257 1147 1003	1330 1303 1130	1333 1229 1075
<b>Cycle Time Freeze</b>	50 / 10 70 / 21 90 / 32	27 29 31	26 26 29	25 27 29	28 31 34	26 27 30	26 29 31	29 33 36	26 28 30	27 31 33	29 33 38	27 28 33	27 31 35
<b>Cycle Time Harvest</b>	50 / 10 70 / 21 90 / 32	4.9 4.3 3.8	4.8 4.3 3.9	5.5 4.8 4.3	4.4 3.4 3.2	4.4 3.7 3.4	5.0 3.9 3.6	4.3 2.7 2.3	4.3 3.2 2.8	4.8 3.2 2.8	3.4 2.6 2.0	3.7 3.1 2.5	4.0 3.1 2.4
<b>Pressure High Side</b>	50 / 10 70 / 21 90 / 32	251 272 293	237 240 251	208 226 247	267 299 316	239 243 258	221 250 269	272 322 341	240 246 260	226 270 290	274 327 359	244 250 272	229 275 309
<b>Pressure Suction</b>	50 / 10 70 / 21 90 / 32	45 48 50	45 46 49	44 47 49	48 52 53	46 48 51	46 50 51	48 56 57	46 49 52	47 53 54	48 56 58	47 50 55	47 53 55

NOTE: Total Cycle Time = Freeze + Harvest Pressure data is recorded 5 minutes into the freeze cycle.



**PERFORMANCE DATA**

MODEL: KM-1400SWH-M & (3)

Supply Voltage: 208-230/60/1 (3 wire w/neutral for 115V)

Total Amperage (Compressor RLA):

Water: 9.7A (8.2A)      3 Ph: 7.1A (6.5A)

Supply Voltage: 3 Ph: 208-230/60/3

Water Consumption for SWH-M/3M Cond:

70/50 (21/10)    **1479/1570** Gal/24hrs

90/70 (32/21)    **2054/2322** Gal/24hrs Ice per cycle:30.9 lbs, 1440 pcs

Ambient Temp (F°/C°)	70 / 21			80 / 27			90 / 32			100 / 38		
	Water Temp F°/C°	Water	3 Ph	Water	3 Ph	Water	3 Ph	Water	3 Ph	Water	3 Ph	
<b>Kg=lbs x.454</b> <b>Production</b> <b>24 hours</b> <b>(lbs)</b>	50 / 10	1370	1343	1353	1323	1347	1317	1307	1272	1272	1272	
	70 / 21	1347	1317	1318	1283	1293	1255	1265	1224	1224	1224	
	90 / 32	1252	1211	1186	1138	1175	1124	1066	1003	1003	1003	
<b>Cycle Time</b> <b>Freeze</b>	50 / 10	30	31	31	32	31	32	32	33	33	33	
	70 / 21	31	32	32	33	33	34	34	35	35	35	
	90 / 32	33	35	35	37	36	37	39	40	40	40	
<b>Cycle Time</b> <b>Harvest</b>	50 / 10	3.9	4.5	3.7	4.1	3.6	4.0	3.3	3.5	3.5	3.5	
	70 / 21	3.6	4.0	3.2	3.4	2.8	2.8	2.8	2.8	2.8	2.8	
	90 / 32	3.3	3.9	3.3	3.5	2.9	2.8	2.9	2.8	2.9	2.8	
<b>Pressure</b> <b>High Side</b>	50 / 10	220	230	227	233	229	234	236	244	244	244	
	70 / 21	229	234	240	240	250	245	255	251	251	251	
	90 / 32	249	255	265	269	273	271	295	295	295	295	
<b>Pressure</b> <b>Suction</b>	50 / 10	50	48	51	49	51	49	53	51	51	51	
	70 / 21	51	49	53	51	55	53	56	54	54	54	
	90 / 32	55	54	58	57	59	58	63	63	63	63	

NOTE: Total Cycle Time = Freeze + harvest      Pressure data is recorded 5 minutes into the freeze cycle.

**PERFORMANCE DATA**

MODEL: KMS-1400MLH & SRK-14H

Supply Voltage: 115/60/1 supplied by SRK

Total Amperage (Compressor RLA): 15A (10.3A)

Ice Production per cycle: 24 lbs, 1248 pcs

Ambient Temp (F°/C°)		70 / 21	80/27	90/32	100/38
Kg=lbs x.454 Production 24 hours (lbs)	Water Temp F°/C°	Low Side	Low Side	Low Side	Low Side
		50 / 10	1284	1252	1242
	70 / 21	1242	1188	1142	1121
	90 / 32	1164	1097	1054	974
Cycle Time Freeze	50 / 10	22	23	24	26
	70 / 21	24	26	27	27
	90 / 32	25	26	28	29
Cycle Time Harvest	50 / 10	6	5	5	4
	70 / 21	5	4	3	3
	90 / 32	5	4	2	2
Pressure High Side	50 / 10	186	200	204	206
	70 / 21	204	228	247	252
	90 / 32	224	245	266	283
Pressure Suction	50 / 10	39	39	40	40
	70 / 21	40	41	42	42
	90 / 32	41	42	43	45

NOTE: Total Cycle Time = Freeze + Harvest

Pressure data is recorded 5 minutes into the freeze cycle.

**PERFORMANCE DATA**

**MODEL: KMS-1401MLH & SRK-14H & H3**

Supply Voltage: 115/60/1 supplied by SRK through wiring harness

**Total Amperage (Compressor RLA): 15.3A (10.3A) 3 Ph: 13.8A ( 8.8A) Ice Production per cycle: 26 lbs, 1248 pcs, 3Ph: 25 lbs, 1248 pcs.**

Ambient Temp (F°/C°)	70 / 21			80/27			90/32			100/38		
	Water Temp F°/C°	Low Side	3 Phase	Low Side	3 Phase	Low Side	3 Phase	Low Side	3 Phase	Low Side	3 Phase	
<b>Kg=lbs x.454 Production 24 hours (lbs)</b>	50 / 10	1311	1305	1286	1275	1278	1265	1248	1237			
	70 / 21	1278	1265	1236	1213	1200	1170	1177	1146			
	90 / 32	1194	1178	1129	1107	1101	1069	1010	977			
<b>Cycle Time Freeze</b>	50 / 10	24	24	25	25	26	25	26	26			
	70 / 21	26	25	27	27	29	28	29	29			
	90 / 32	28	27	30	29	31	30	33	32			
<b>Cycle Time Harvest</b>	50 / 10	5.5	5.2	4.8	4.7	4.6	4.5	3.7	3.6			
	70 / 21	4.6	4.5	3.5	3.5	2.5	2.7	2.5	2.6			
	90 / 32	4.2	4.1	3.5	3.5	2.4	2.5	2.3	2.3			
<b>Pressure High Side</b>	50 / 10	192	180	204	194	208	198	210	201			
	70 / 21	208	198	229	222	246	242	250	247			
	90 / 32	225	218	244	240	263	261	278	279			
<b>Pressure Suction</b>	50 / 10	40	42	41	43	41	43	42	44			
	70 / 21	41	43	43	45	45	46	45	46			
	90 / 32	43	45	45	47	47	48	49	50			

NOTE: Total Cycle Time = Freeze + Harvest

Pressure data is recorded 5 minutes into the freeze cycle.

**PERFORMANCE DATA**

**MODEL: KMS-1401MLJ & SRK-14J & J3**

Supply Voltage: 115/60/1 supplied by SRK through wiring harness

Total Amperage (Compressor RLA): 13.5A (10.3A) 3 Ph: 11.5A ( 8.8A)

Ice Production per cycle: 25.8 lbs, 1248 pcs, 3Ph: 26.7 lbs, 1248 pcs.

Ambient Temp (F°/C°)	70 / 21			80/27			90/32			100/38		
	Water Temp F°/C°	Low Side	3 Phase	Low Side	3 Phase	Low Side	3 Phase	Low Side	3 Phase	Low Side	3 Phase	
<b>Kg=lbs x.454 Production 24 hours (lbs)</b>	50 / 10 70 / 21 90 / 32	1420 1379 1278	1400 1365 1266	1389 1325 1199	1373 1319 1191	1379 1280 1162	1365 1280 1163	1344 1252 1054	1328 1253 1055			
<b>Cycle Time Freeze</b>	50 / 10 70 / 21 90 / 32	25 26 27	24 25 28	25 26 27	25 28 30	25 27 30	25 28 31	26 28 33	26 29 33			
<b>Cycle Time Harvest</b>	50 / 10 70 / 21 90 / 32	4.6 3.9 3.6	5.3 4.4 4.1	4.0 3.0 3.1	4.6 3.3 3.4	3.9 2.2 2.2	4.4 2.3 2.2	3.1 2.2 2.1	3.5 2.3 2.1			
<b>Pressure High Side</b>	50 / 10 70 / 21 90 / 32	178 197 219	175 197 221	192 221 241	192 226 246	197 242 263	197 250 272	200 247 283	200 255 293			
<b>Pressure Suction</b>	50 / 10 70 / 21 90 / 32	46 47 50	46 48 52	47 49 52	48 51 55	47 51 54	48 53 57	48 52 56	49 54 61			

NOTE: Total Cycle Time = Freeze + Harvest

Pressure data is recorded 5 minutes into the freeze cycle.

**PERFORMANCE DATA**

**MODEL: KM-1600MRH**

Supply Voltage: 208-230/60/1 (3 wire w/neutral for 115V)

Total Amperage (Compressor RLA): Remote: 18A (18.6A)

Ice Production per cycle: 28.6 lbs, 1440 pcs

Ambient Temp (F°/C°)	70 / 21	80 / 27	90 / 32	100 / 32
Water Temp F°/C°	Remote	Remote	Remote	Remote
<b>Kg=lbs x.454</b>				
<b>Production</b>				
<b>24 hours</b>	1486	1454	1444	1411
<b>(lbs)</b>	1444	1389	1343	1317
	1347	1270	1231	1128
<b>Cycle Time</b>				
<b>Freeze</b>	23	24	24	25
	24	26	27	27
	26	28	29	31
<b>Cycle Time</b>				
<b>Harvest</b>	4.5	4.2	4.1	4.0
	4.1	3.5	3.0	2.9
	3.5	3.0	2.5	2.0
<b>Pressure</b>				
<b>High Side</b>	227	236	239	244
	239	254	267	272
	259	277	289	310
<b>Pressure</b>				
<b>Suction</b>	40	41	42	42
	42	44	46	46
	44	46	48	50

Pressure data is recorded 5 minutes into the freeze cycle.

NOTE: Total Cycle Time = Freeze + Harvest

**PERFORMANCE DATA**

MODEL: KM-1600MRH3

Supply Voltage: 208-230/60/3

Total Amperage (Compressor RLA): Remote: 11A (9.5A)

Ice Production per cycle: 28.6 lbs, 1440 pcs

	Ambient Temp (F°/C°)		70 / 21		80 / 27		90 / 32		100 / 38	
	Water Temp F°/C°	Remote	Water Temp F°/C°	Remote	Water Temp F°/C°	Remote	Water Temp F°/C°	Remote	Water Temp F°/C°	Remote
<b>Kg= lbs x.454</b> <b>Production</b> <b>24 hours</b> <b>(lbs)</b>	50 / 10	1524	50 / 10	1486	50 / 10	24	50 / 10	24	50 / 10	25
	70 / 21	1474	70 / 21	1409	70 / 21	24	70 / 21	27	70 / 21	27
	90 / 32	1392	90 / 32	1319	90 / 32	26	90 / 32	29	90 / 32	31
<b>Cycle Time</b> <b>Freeze</b>	50 / 10	4.5	50 / 10	4.2	50 / 10	4.2	50 / 10	4.1	50 / 10	4.0
	70 / 21	4.1	70 / 21	3.5	70 / 21	4.1	70 / 21	3.0	70 / 21	2.9
	90 / 32	3.5	90 / 32	3.0	90 / 32	3.5	90 / 32	2.5	90 / 32	2.0
<b>Cycle Time</b> <b>Harvest</b>	50 / 10	225	50 / 10	234	50 / 10	234	50 / 10	237	50 / 10	244
	70 / 21	237	70 / 21	252	70 / 21	252	70 / 21	265	70 / 21	271
	90 / 32	260	90 / 32	279	90 / 32	279	90 / 32	291	90 / 32	315
<b>Pressure</b> <b>High Side</b>	50 / 10	35	50 / 10	37	50 / 10	37	50 / 10	37	50 / 10	38
	70 / 21	37	70 / 21	40	70 / 21	40	70 / 21	42	70 / 21	43
	90 / 32	40	90 / 32	42	90 / 32	42	90 / 32	45	90 / 32	47

NOTE: Total Cycle Time = Freeze + Harvest

Pressure data is recorded 5 minutes into the freeze cycle.

**PERFORMANCE DATA**

MODEL: KM-1600S\_H

Supply Voltage: 208-230/60/1 (3 wire w/neutral for 115V)

Total Amperage (Compressor RLA):

Water: 15A (14A)

Remote: 21A (14A)

Ice Production per cycle: 30.9 lbs, 1440 pcs

Water Consumption for SWH Condenser:

70/50 (21/10)

1061 Gal/24hrs

90/70 (32/21)

1993 Gal/24hrs

Ambient Temp (F°/C°)		70 / 21		80 / 27		90 / 32		100 / 38	
Kg=lbs x.454 Production 24 hours (lbs)	Water Temp F°/C°	Water	Remote	Water	Remote	Water	Remote	Water	Remote
		50 / 10	1551	1430	1553	1423	1553	1421	1507
	70 / 21	1553	1421	1556	1410	1558	1400	1531	1376
	90 / 32	1468	1343	1422	1295	1443	1299	1338	1207
Cycle Time Freeze	50 / 10	24	25	24	26	25	26	25	26
	70 / 21	25	26	25	27	26	28	26	28
	90 / 32	26	28	28	29	28	30	30	32
Cycle Time Harvest	50 / 10	4.7	5.5	4.3	4.9	4.1	4.8	3.8	3.9
	70 / 21	4.1	4.8	3.8	3.8	2.7	3.0	2.7	2.9
	90 / 32	3.9	4.3	3.5	3.7	2.7	2.7	2.7	2.5
Pressure High Side	50 / 10	271	225	271	233	272	235	273	242
	70 / 21	272	235	272	249	273	260	274	265
	90 / 32	275	256	277	273	277	283	281	305
Pressure Suction	50 / 10	39	38	40	39	40	39	41	40
	70 / 21	40	39	42	41	43	43	44	43
	90 / 32	42	41	44	43	46	45	48	47

NOTE: Total Cycle Time = Freeze + Harvest

Pressure data is recorded 5 minutes into the freeze cycle.

**PERFORMANCE DATA**

MODEL: KM-1600S\_H3

Supply Voltage: 208-230/60/3

Total Amperage (Compressor RLA): Water: 9.5A (9A) Remote: 11A (9.5A) Ice Production per cycle: 30.9 lbs, 1440 pcs

Water Consumption for SWH Condenser: 70/50 (21/10) 1005 Gal/24hrs 90/70 (32/21) 1740 Gal/24hrs

Ambient Temp (F°/C°)	70 / 21		80 / 27		90 / 32		100 / 38	
	Water	Remote	Water	Remote	Water	Remote	Water	Remote
<b>Kg=lbs x.454</b>								
<b>Production</b>	1500	1461	1510	1442	1514	1436	1473	1409
<b>24 hours</b>	1514	1436	1532	1403	1547	1375	1526	1355
<b>(lbs)</b>	1451	1365	1423	1311	1456	1291	1373	1213
<b>Cycle Time</b>	24	25	24	25	25	26	25	26
<b>Freeze</b>	25	26	25	26	26	27	26	27
	26	27	26	29	27	29	28	31
<b>Cycle Time</b>	5.0	5.5	4.4	4.9	4.3	4.8	3.4	3.9
<b>Harvest</b>	4.3	4.8	3.3	3.8	2.5	3.0	2.4	2.9
	3.8	4.3	3.2	3.7	2.2	2.7	2.0	2.5
<b>Pressure</b>	270	225	271	233	271	235	272	240
<b>High Side</b>	271	235	273	249	275	260	276	264
	274	252	276	267	278	278	280	295
<b>Pressure</b>	40	37	41	38	41	38	42	39
<b>Suction</b>	41	38	42	39	43	40	44	41
	43	41	45	43	46	44	48	47

NOTE: Total Cycle Time = Freeze + Harvest Pressure data is recorded 5 minutes into the freeze cycle.



**PERFORMANCE DATA**

MODEL: KM-1601MRH

Supply Voltage: 208-230/60/1 (3 wire w/neutral for 115V)

Total Amperage (Compressor RLA): Remote: 11.6A (8.6A)

Ice Production per cycle: 29.8 lbs, 1440 pcs

	Water Temp		80 / 27		90 / 32		100 / 38	
	F°/C°	Remote	Remote	Remote	Remote	Remote	Remote	Remote
<b>Kg=lbs x .454</b> <b>Production</b> <b>24 hours</b> <b>(lbs)</b>	50 / 10	1508	1489	1483	1449	1443	1449	
	70 / 21	1483	1450	1422	1398	1422	1398	
	90 / 32	1399	1338	1320	1227	1320	1227	
<b>Cycle Time</b> <b>Freeze</b>	50 / 10	23	24	24	24	24	24	
	70 / 21	24	25	27	27	27	27	
	90 / 32	26	27	28	30	28	30	
<b>Cycle Time</b> <b>Harvest</b>	50 / 10	5.3	4.8	4.6	3.7	4.6	3.7	
	70 / 21	4.6	3.6	2.8	2.8	2.8	2.8	
	90 / 32	4.1	3.4	2.5	2.2	2.5	2.2	
<b>Pressure</b> <b>High Side</b>	50 / 10	200	211	215	217	215	217	
	70 / 21	215	234	251	254	251	254	
	90 / 32	231	249	266	281	266	281	
<b>Pressure</b> <b>Suction</b>	50 / 10	35	36	37	37	37	37	
	70 / 21	37	39	41	41	41	41	
	90 / 32	39	41	43	45	43	45	

NOTE: Total Cycle Time = Freeze + Harvest

Pressure data is recorded 5 minutes into the freeze cycle.

**PERFORMANCE DATA**

MODEL: KM-1601MRH3

Supply Voltage: 208-230/60/3

Total Amperage (Compressor RLA): Remote: 8.4A (6.9A)

Ice Production per cycle: 28.0 lbs, 1440 pcs

Kg=lbs x .454 Production 24 hours (lbs)	Ambient Temp (F°/C°)			Ice Production per cycle: 28.0 lbs, 1440 pcs		
	Water Temp F°/C°	70 / 21	80 / 27	90 / 32	100 / 38	Remote
	50 / 10	1471	1453	1448	1408	Remote
	70 / 21	1448	1417	1392	1365	
	90 / 32	1354	1290	1277	1171	
<b>Cycle Time Freeze</b>	50 / 10	23	23	24	24	24
	70 / 21	24	25	27	27	27
	90 / 32	26	27	29	31	31
<b>Cycle Time Harvest</b>	50 / 10	5.7	5.1	4.9	4.0	4.0
	70 / 21	4.9	3.9	3.1	3.0	3.0
	90 / 32	4.4	3.6	2.7	2.3	2.3
<b>Pressure High Side</b>	50 / 10	203	214	218	224	224
	70 / 21	218	237	253	259	259
	90 / 32	242	263	279	303	303
<b>Pressure Suction</b>	50 / 10	38	40	40	40	40
	70 / 21	40	43	45	45	45
	90 / 32	42	44	47	48	48

NOTE: Total Cycle Time = Freeze + Harvest

Pressure data is recorded 5 minutes into the freeze cycle.

**PERFORMANCE DATA**

MODEL: KM-1601S\_H

Supply Voltage: 208-230/60/1 (3 wire w/neutral for 115V)

Total Amperage (Compressor RLA):

Water: 13.4A (12.1A)

Remote: 12.8A (11.3A)

Ice Production per cycle: 30.2 lbs, 1440 pcs

Water Consumption for SWH Condenser: 70/50 (21/10) 1628 Gal/24hrs

90/70 (32/21) 1866 Gal/24hrs

Ambient Temp (F°/C°)	70 / 21		80 / 27		90 / 32		100 / 38	
	Water	Remote	Water	Remote	Water	Remote	Water	Remote
<b>Kg= lbs x.454</b>								
<b>Production</b>								
<b>24 hours</b>								
<b>(lbs)</b>								
<b>Cycle Time</b>								
<b>Freeze</b>								
<b>Cycle Time</b>								
<b>Harvest</b>								
<b>Pressure</b>								
<b>High Side</b>								
<b>Pressure</b>								
<b>Suction</b>								
50 / 10	24	24	24	25	25	25	25	26
70 / 21	25	25	25	27	26	28	26	29
90 / 32	26	27	28	29	28	30	30	32
50 / 10	4.7	5.6	4.3	4.8	4.1	4.6	3.8	3.6
70 / 21	4.1	4.6	3.8	3.4	2.7	2.4	2.7	2.3
90 / 32	3.9	4.2	3.5	3.4	2.7	2.2	2.7	2.0
50 / 10	271	201	271	211	272	215	273	219
70 / 21	272	215	272	233	273	248	274	253
90 / 32	275	235	277	254	277	269	281	288
50 / 10	39	36	40	38	40	38	41	39
70 / 21	40	38	42	41	43	43	44	44
90 / 32	42	41	44	44	46	47	48	50

NOTE: Total Cycle Time = Freeze + Harvest

Pressure data is recorded 5 minutes into the freeze cycle.

**PERFORMANCE DATA**

MODEL: KM-1601S\_H3

Supply Voltage: 208-230/60/3

Total Amperage (Compressor RLA): Water: 9A (7.3A) Remote: 7.9A (6.4A) Ice Production per cycle: 30.2 lbs, 1440 pcs

Water Consumption for SWH3 Condenser: 70/50 (21/10) 1714 Gal/24hrs

90/70 (32/21) 1937 Gal/24hrs

	70 / 21		80 / 27		90 / 32		100 / 38		
	Water Temp F°/C°	Water	Remote	Water	Remote	Water	Remote	Water	Remote
<b>Kg= lbs x.454 Production 24 hours (lbs)</b>	50 / 10 70 / 21 90 / 32	1555 1558 1466	1585 1563 1464	1557 1562 1417	1568 1535 1396	1558 1565 1440	1563 1511 1387	1507 1536 1326	1520 1482 1273
<b>Cycle Time Freeze</b>	50 / 10 70 / 21 90 / 32	24 24 26	24 25 27	24 25 27	25 27 29	24 26 28	25 28 30	25 26 30	26 29 32
<b>Cycle Time Harvest</b>	50 / 10 70 / 21 90 / 32	6.0 4.9 4.4	5.5 4.6 4.1	5.2 3.6 3.6	4.8 3.4 3.4	4.9 2.4 2.2	4.6 2.4 2.2	3.8 2.4 2.0	3.6 2.4 2.0
<b>Pressure High Side</b>	50 / 10 70 / 21 90 / 32	239 241 257	202 215 237	240 244 268	212 233 257	241 246 267	215 247 271	249 251 287	221 253 293
<b>Pressure Suction</b>	50 / 10 70 / 21 90 / 32	41 42 45	37 39 42	42 44 47	38 41 45	42 45 48	39 43 47	43 46 51	40 44 51

NOTE: Total Cycle Time = Freeze + Harvest

Pressure data is recorded 5 minutes into the freeze cycle.

**PERFORMANCE DATA**

MODEL: KM-1800S\_H

Supply Voltage: 208-230/60/1 (3wire w/neutral for 115V)

Total Amperage (Compressor RLA): Air: 18A (13A) Water: 12.4A (10.9A) Remote: 16.5A (10.9A) Ice Production per cycle: 42.9 lbs, 2160 pcs

Water Consumption for SWH Condenser: 70/50 (21/10) 1640 Gal/24hrs 90/70 (32/21) 1998 Gal/24hrs

Kg=lbs x.454 Production 24 hours (lbs)	70 / 21			80 / 27			90 / 32			100 / 38		
	Air	Water	Remote	Air	Water	Remote	Air	Water	Remote	Air	Water	Remote
<b>Cycle Time Freeze</b>	Water Temp F°/C°											
	50 / 10	1756	1816	1817	1708	1812	1780	1810	1768	1590	1801	1723
	70 / 21	1692	1810	1768	1609	1803	1704	1797	1651	1513	1791	1617
<b>Cycle Time Harvest</b>	90 / 32	1589	1789	1643	1496	1774	1546	1770	1504	1326	1746	1369
	50 / 10	31	31	32	33	31	33	31	34	37	31	35
	70 / 21	33	31	34	36	32	36	32	38	40	32	39
<b>Pressure High Side</b>	90 / 32	36	32	37	39	32	39	33	41	45	33	44
	50 / 10	6.0	5.7	5.4	5.4	5.1	5.0	4.9	4.9	4.2	4.0	4.2
	70 / 21	5.3	4.9	4.9	4.3	3.9	4.2	3.5	3.0	3.7	2.9	3.6
<b>Pressure Suction</b>	90 / 32	4.6	4.4	4.4	3.9	3.7	3.8	3.0	3.2	2.5	2.4	2.8
	50 / 10	230	256	220	246	255	226	251	227	255	256	235
	70 / 21	251	255	227	278	253	237	300	252	306	252	250
	90 / 32	277	255	247	303	255	262	326	253	268	254	290
<b>Pressure Suction</b>	50 / 10	50	50	40	51	50	41	51	50	41	50	42
	70 / 21	51	50	41	53	50	43	55	50	45	50	46
	90 / 32	54	50	44	56	50	46	58	50	48	50	50

NOTE: Total Cycle Time = Freeze + Harvest Pressure data is recorded 5 minutes into the freeze cycle.

**PERFORMANCE DATA**

MODEL: KM-1800S\_H3

Supply Voltage: 208-230/60/3

Total Amperage (Compressor RLA): Air: 11A (7.5A) Water: 9.7A (8.2A) Remote: 10.9A (7.5A) Ice Production per cycle: 43.7 lbs, 2160 pcs

Water Consumption for SWH3 Condenser: 70/50 (21/10) 870 Gal/24hrs 90/70 (32/21) 1282 Gal/24hrs

Ambient Temp (F°/C°)	70 / 21			80 / 27			90 / 32			100 / 38		
	Air	Water	Remote	Air	Water	Remote	Air	Water	Remote	Air	Water	Remote
<b>Kg=lbs x.454 Production 24 hours (lbs)</b>	50 / 10	1757	1761	1707	1765	1735	1691	1766	1722	1597	1742	1691
	70 / 21	1691	1766	11604	1773	1658	1532	1778	1595	1509	1765	1568
	90 / 32	1597	1726	1507	1707	1531	1434	1722	1479	1344	1671	1372
<b>Cycle Time Freeze</b>	50 / 10	32	31	34	31	33	34	31	34	38	31	35
	70 / 21	34	31	37	32	37	40	33	39	41	33	39
	90 / 32	37	32	40	32	40	43	33	42	45	33	45
<b>Cycle Time Harvest</b>	50 / 10	6.0	5.7	5.3	5.1	5.3	5.1	4.9	5.1	4.1	4.0	4.3
	70 / 21	5.1	4.9	4.0	3.9	4.3	3.0	3.0	3.6	2.9	2.9	3.5
	90 / 32	4.6	4.4	3.9	3.7	4.0	2.7	2.7	3.2	2.5	2.4	2.8
<b>Pressure High Side</b>	50 / 10	240	253	257	252	231	262	252	232	291	253	234
	70 / 21	262	252	291	250	242	315	249	250	319	249	252
	90 / 32	283	253	306	253	252	333	251	260	350	253	270
<b>Pressure Suction</b>	50 / 10	52	50	53	50	44	53	50	44	54	50	45
	70 / 21	53	50	54	50	46	55	50	48	56	50	48
	90 / 32	55	51	57	51	48	58	51	50	60	52	52

NOTE: Total Cycle Time = Freeze + Harvest

Pressure data is recorded 5 minutes into the freeze cycle.

**PERFORMANCE DATA**

MODEL: KM-1900S\_H

Supply Voltage: 208-230/60/1 (3wire w/neutral for 115V)

Total Amperage (Compressor RLA): Air: 14.4A (11.3A) Water: 12.5A (11.1A) Remote: 14.9A (11.4A) Ice Production per cycle: 47 lbs, 2160 pcs

Water Consumption for SWH Condenser: 70/50 (21/10) 1022 Gal/24hrs 90/70 (32/21) 1832 Gal/24hrs

	70 / 21			80 / 27			90 / 32			100 / 38		
	Air	Water	Remote	Air	Water	Remote	Air	Water	Remote	Air	Water	Remote
<b>Water Temp</b>												
<b>F°/C°</b>												
<b>Kg=lbs x .454</b>												
<b>Production</b>	1867	1876	1915	1798	1870	1848	1777	1868	1827	1744	1800	1786
<b>24 hours</b>	1777	1868	1827	1659	1858	1712	1560	1850	1616	1526	1809	1577
<b>(lbs)</b>	1638	1734	1676	1511	1655	1543	1413	1673	1451	1278	1511	1299
<b>Cycle Time</b>	32	32	31	34	33	33	34	33	33	36	34	34
<b>Freeze</b>	34	33	33	37	34	36	40	35	38	41	35	39
	39	35	37	42	37	40	44	38	43	49	41	46
<b>Cycle Time</b>	4.8	4.6	4.9	4.4	4.2	4.5	4.2	4.1	4.4	3.6	3.5	4.0
<b>Harvest</b>	4.2	4.1	4.4	3.4	3.4	3.9	2.8	2.8	3.4	2.7	2.8	3.4
	4.0	3.9	4.3	3.5	3.4	4.0	2.7	2.7	3.4	2.7	2.7	3.4
<b>Pressure</b>	241	238	212	258	240	224	263	241	228	266	247	231
<b>High Side</b>	263	241	228	291	245	249	315	249	267	321	253	271
	288	254	247	314	263	266	339	265	285	362	279	301
<b>Pressure</b>	49	49	49	50	49	50	50	49	50	51	50	51
<b>Suction</b>	50	49	50	52	50	52	53	50	53	53	50	53
	52	51	52	54	51	54	55	52	55	57	53	57

NOTE: Total Cycle Time = Freeze + Harvest Pressure data is recorded 5 minutes into the freeze cycle.

**PERFORMANCE DATA**

MODEL: KM-1900S\_H3

Supply Voltage: 208-230/60/1 (3wire w/neutral for 115V)

Total Amperage (Compressor RLA): Air: 8.6A (8.4A) Water: 8.4A (7.8A) Remote: 11A (8A) Ice Production per cycle: 45.9 lbs, 2160 pcs

Water Consumption for SWH3 Condenser: 70/50 (21/10) 982 Gal/24hrs 90/70 (32/21) 1796 Gal/24hrs

Kg=lbs x.454 Production 24 hours (lbs)	70 / 21			80 / 27			90 / 32			100 / 38		
	Air	Water	Remote	Air	Water	Remote	Air	Water	Remote	Air	Water	Remote
<b>Cycle Time Freeze</b>	Water Temp F°/C°											
	50 / 10	1825	1823	1786	1823	1897	1763	1822	1876	1738	1754	1827
	70 / 21	1763	1818	1636	1818	1758	1530	1814	1660	1499	1774	1617
<b>Cycle Time Harvest</b>	90 / 32	1633	1693	1507	1619	1566	1398	1642	1474	1277	1484	1304
	50 / 10	32	32	34	33	33	34	33	33	35	34	34
	70 / 21	34	33	37	34	36	40	34	38	41	35	39
<b>Pressure High Side</b>	90 / 32	38	35	41	37	40	44	38	42	48	41	46
	50 / 10	4.5	4.7	4.1	4.2	4.5	4.0	4.1	4.4	3.4	3.5	4.0
	70 / 21	4.0	4.1	3.3	3.4	3.8	2.7	2.7	3.4	2.7	2.7	3.4
<b>Pressure Suction</b>	90 / 32	3.8	3.9	3.4	3.5	4.0	2.7	2.7	3.4	2.7	2.7	3.4
	50 / 10	237	239	255	241	215	260	241	219	262	248	220
	70 / 21	260	241	291	244	241	317	246	259	322	250	263
<b>Pressure Suction</b>	90 / 32	284	255	311	264	255	339	264	275	359	280	289
	50 / 10	50	50	51	50	49	51	50	50	52	51	50
	70 / 21	51	50	53	50	50	54	50	51	55	50	51
<b>Pressure Suction</b>	90 / 32	53	51	55	52	53	57	52	53	59	53	55

NOTE: Total Cycle Time = Freeze + Harvest Pressure data is recorded 5 minutes into the freeze cycle.



**PERFORMANCE DATA**

MODEL: KM-2000S\_H3

Supply Voltage: 208-230/60/3

Total Amperage (Compressor RLA):

Water: 9.5A (8.5A) Remote: 12A (9A)

Ice Production per cycle: 46.3 lbs, 2160 pcs

Water Consumption for SWH3 Condenser: 70/50 (21/10) 964 Gal/24hrs

90/70 (32/21) 1435 Gal/24hrs

Ambient Temp (F°/C°)		70 / 21		80 / 27		90 / 32		100 / 38	
Kg=lbs x.454 Production 24 hours (lbs)	Water Temp F°/C°	Water	Remote	Water	Remote	Water	Remote	Water	Remote
		50 / 10	1891	1865	1885	1839	1883	1831	1851
	70 / 21	1883	1831	1873	1786	1864	1748	1844	1725
	90 / 32	1817	1746	1776	1679	1740	1649	1701	1558
Cycle Time Freeze	50 / 10	30	30	30	31	31	31	31	32
	70 / 21	31	31	31	33	32	34	32	34
	90 / 32	32	33	33	35	34	36	35	38
Cycle Time Harvest	50 / 10	5.0	5.0	4.5	4.6	4.3	4.4	4.0	4.4
	70 / 21	4.3	4.4	3.4	3.6	2.7	3.0	2.6	2.9
	90 / 32	3.9	3.8	3.3	3.2	2.4	2.5	2.2	2.0
Pressure High Side	50 / 10	275	233	275	241	275	243	276	249
	70 / 21	275	243	276	257	276	268	276	273
	90 / 32	276	263	277	280	277	290	278	310
Pressure Suction	50 / 10	48	45	48	45	48	46	48	46
	70 / 21	48	46	49	46	49	47	49	47
	90 / 32	49	47	49	48	50	49	50	50

NOTE: Total Cycle Time = Freeze + Harvest

Pressure data is recorded 5 minutes into the freeze cycle.

**PERFORMANCE DATA**

MODEL: KMH-2000S\_H3

Supply Voltage: 208-230/60/3

Total Amperage (Compressor RLA): Water: 7.7A (6.8A) Remote: 9.9A (7.9A) Ice Production per cycle: 46.9 lbs, 2160 pcs

Water Consumption for SWH3 Condenser: 70/50 (21/10) 1567 Gal/24hrs 90/70 (32/21) 2191 Gal/24hrs

Water Temp F°/C°	70 / 21		80 / 27		90 / 32		100 / 38	
	Water	Remote	Water	Remote	Water	Remote	Water	Remote
<b>Kg=lbs x.454 Production 24 hours (lbs)</b>	1843 1842 1723	1929 1855 1719	1842 1841 1657	1872 1757 1602	1842 1840 1681	1855 1675 1525	1779 1830 1535	1816 1640 1388
<b>Cycle Time Freeze</b>	50/10 70/21 90/32	32 34 37	33 34 37	34 36 40	33 34 37	34 37 41	34 35 40	35 38 45
<b>Cycle Time Harvest</b>	50/10 70/21 90/32	4.6 4.1 3.9	4.2 3.4 3.5	4.6 4.4 4.4	4.1 2.8 2.8	4.6 4.3 4.3	3.5 2.8 2.7	4.4 4.3 4.3
<b>Pressure High Side</b>	50/10 70/21 90/32	243 244 259	244 246 268	220 241 254	244 248 267	223 255 269	252 253 285	225 258 282
<b>Pressure Suction</b>	50/10 70/21 90/32	47 48 49	45 45 46	47 48 50	45 45 46	48 49 51	45 45 47	48 49 52

NOTE: Total Cycle Time = Freeze + Harvest

Pressure data is recorded 5 minutes into the freeze cycle.

**PERFORMANCE DATA**

**MODEL: KMS-2000MLH & SRK-20H & H3**

**Supply Voltage: 115/60/1 supplied by SRK through wiring harness**

**Total Amperage (Compressor RL(A): 21.3A (17.5A) 3 Ph: 11A ( 9.5A)**

**Ice Production per cycle: 27.9 lbs, 1560 pcs, 3Ph: 27.4 lbs, 1560 pcs.**

Ambient Temp (F°/C°)	70 / 21			80/27			90/32			100/38		
	Water Temp F°/C°	Low Side	3 Phase	Low Side	3 Phase	Low Side	3 Phase	Low Side	3 Phase	Low Side	3 Phase	
<b>Kg=lbs x.454 Production 24 hours (lbs)</b>	50 / 10 70 / 21 90 / 32	1861 1839 1722	1910 1850 1767	1844 1810 1645	1864 1772 1687	1839 1786 1639	1850 1706 1620	1786 1752 1504	1833 1686 1541			
<b>Cycle Time Freeze</b>	50 / 10 70 / 21 90 / 32	19 19 21	18 19 20	19 20 22	19 20 21	19 21 22	19 21 22	20 21 24	19 21 24	20 21 24	19 21 24	
<b>Cycle Time Harvest</b>	50 / 10 70 / 21 90 / 32	4.2 3.7 3.4	4.2 3.7 3.3	3.8 3.0 2.9	3.8 3.0 2.9	3.7 2.4 2.2	3.7 2.4 2.2	3.0 2.4 2.0	3.0 2.4 2.0	3.0 2.4 2.0	3.0 2.4 2.0	
<b>Pressure High Side</b>	50 / 10 70 / 21 90 / 32	200 212 224	203 214 233	209 229 238	211 229 250	212 242 253	214 241 261	213 245 263	219 246 280	213 245 263	219 246 280	
<b>Pressure Suction</b>	50 / 10 70 / 21 90 / 32	41 43 44	40 41 44	42 45 46	41 43 46	43 45 49	41 44 47	43 47 50	42 45 50	43 47 50	42 45 50	

NOTE: Total Cycle Time = Freeze + Harvest

Pressure data is recorded 5 minutes into the freeze cycle.

**PERFORMANCE DATA**

MODEL: KM-2100S\_H3

Supply Voltage: 208-230/60/3

Total Amperage (Compressor RLA): Water: 10.5A (9A) Remote: 12.5A (9.2A) Ice Production per cycle: 46.8 lbs, 2160 pcs

Water Consumption for SWH3 Condenser: 70/50 (21/10) 1121 Gal/24hrs 90/70 (32/21) 1948 Gal/24hrs

Ambient Temp (F°/C°)	70 / 21		80 / 27		90 / 70 (32/21)		90 / 32		100 / 38		
	Water Temp F°/C°	Water	Remote	Water	Remote	Water	Remote	Water	Remote	Water	Remote
<b>Kg=lbs x.454 Production 24 hours (lbs)</b>	50 / 10	2096	2034	2086	1984	2083	1968	2005	1908	2005	1908
	70 / 21	2083	1968	2065	1882	2050	1810	2003	1764	2003	1764
	90 / 32	1927	1800	1834	1670	1848	1613	1662	1432	1662	1432
<b>Cycle Time Freeze</b>	50 / 10	28	29	29	30	29	30	30	32	30	32
	70 / 21	29	30	30	33	31	35	31	36	31	36
	90 / 32	31	34	33	37	33	38	36	42	36	42
<b>Cycle Time Harvest</b>	50 / 10	4.9	5.4	4.5	5.0	4.4	4.9	3.8	4.3	3.8	4.3
	70 / 21	4.4	4.9	3.7	4.2	3.2	3.6	3.1	3.5	3.1	3.5
	90 / 32	4.0	4.6	3.6	4.2	2.9	3.5	2.7	3.4	2.7	3.4
<b>Pressure High Side</b>	50 / 10	244	217	247	229	248	233	255	236	255	236
	70 / 21	248	233	254	253	258	270	263	274	263	274
	90 / 32	264	252	275	271	278	289	296	306	296	306
<b>Pressure Suction</b>	50 / 10	48	45	48	46	48	46	49	46	49	46
	70 / 21	48	46	49	48	49	49	49	49	49	49
	90 / 32	49	48	50	49	50	51	51	51	51	52

NOTE: Total Cycle Time = Freeze + Harvest Pressure data is recorded 5 minutes into the freeze cycle.

**PERFORMANCE DATA**

MODEL: KM-2400SRH3

Supply Voltage: 208-230/60/3

Total Amperage (Compressor RLA): Remote: 17A (15A)

Ice Production per cycle: 44 lbs, 2160 pcs

Ambient Temp (F°/C°)		70 / 21	80 / 27	90 / 32	100 / 38
Water Temp F°/C°		Remote	Remote	Remote	Remote
<b>Kg=lbs x.454 Production 24 hours (lbs)</b>	50 / 10	2301	2305	2307	2231
	70 / 21	2307	2315	2321	2278
	90 / 32	2172	2100	1980	1968
<b>Cycle Time Freeze</b>	50 / 10	23	23	24	24
	70 / 21	24	24	25	26
	90 / 32	26	27	28	30
<b>Cycle Time Harvest</b>	50 / 10	5.7	5.2	5.0	4.8
	70 / 21	5.0	4.1	3.4	3.4
	90 / 32	4.7	4.2	3.3	3.2
<b>Pressure High Side</b>	50 / 10	237	244	247	253
	70 / 21	247	259	270	275
	90 / 32	267	283	292	313
<b>Pressure Suction</b>	50 / 10	52	53	53	54
	70 / 21	53	54	55	56
	90 / 32	55	57	58	60

NOTE: Total Cycle Time = Freeze + Harvest

Pressure data is recorded 5 minutes into the freeze cycle.

**PERFORMANCE DATA**

MODEL: KM-2500S\_H3

Supply Voltage: 208-230/60/3

Total Amperage (Compressor RLA): Water: 14.2A (12.2A) Remote: 17.7 A (15.4A)

Ice Production per cycle: 46.3 lbs, 2160 pcs

Water Consumption for SWH3 Condenser: 70/50 (21/10) 1430 Gal/24hrs

90/70 (32/21) 1430 Gal/24hrs

	70 / 21		80 / 27		90 / 32		100 / 38		
	Water Temp F°/C°	Water	Remote	Water	Remote	Water	Remote	Water	Remote
<b>Kg=lbs x.454 Production 24 hours (lbs)</b>	50 / 10	2408	2424	2398	2385	2395	2373	2327	2301
	70 / 21	2395	2373	2379	2306	2365	2250	2323	2200
	90 / 32	2256	2196	2172	2069	2184	2035	2018	1837
<b>Cycle Time Freeze</b>	50 / 10	24	25	24	26	24	26	25	27
	70 / 21	24	26	27	27	26	27	26	28
	90 / 32	26	28	30	28	28	30	30	32
<b>Cycle Time Harvest</b>	50 / 10	5.0	5.0	4.6	4.5	4.4	4.3	25	3.6
	70 / 21	4.4	4.3	3.7	3.5	3.1	2.8	26	2.8
	90 / 32	4.1	4.1	3.6	3.6	2.9	2.7	30	2.7
<b>Pressure High Side</b>	50 / 10	245	214	249	227	250	231	259	236
	70 / 21	250	231	256	253	261	271	267	277
	90 / 32	272	255	287	277	289	296	314	319
<b>Pressure Suction</b>	50 / 10	39	35	39	36	40	36	41	37
	70 / 21	40	36	40	38	41	39	42	39
	90 / 32	42	38	44	40	44	41	47	43

NOTE: Total Cycle Time = Freeze + Harvest

Pressure data is recorded 5 minutes into the freeze cycle.

## 10-PIN CONNECTOR FOR E & G BOARDS:

**NOTE:** This connector diagram shows the standard color code and component layouts. Use it as a guide for circuit diagnosis.

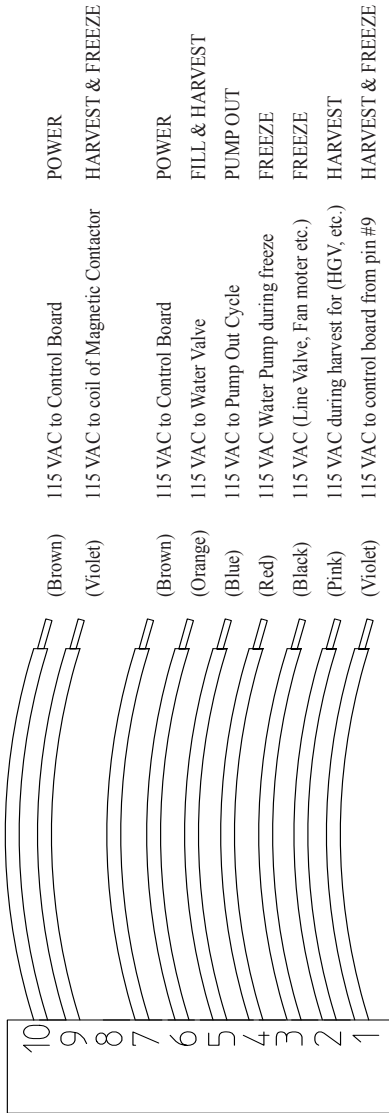

## KM Wiring Diagrams

The wiring diagrams on the following pages are generic in some cases because they can represent several models. Hoshizaki provides a specific wiring label on every unit for electrical diagnosis. You will also find wiring diagrams in the service manual by model. See the following wiring diagram chart for your model and capacitor information.

## KM Wiring Diagram Reference Chart:

Note: All capacitor values are in MFD.

Model	Wiring Diagram	Page	Start Capacitor	Run Capacitor	Pump Capacitor	Fan Capacitor
Mechanical Bin Control		207				
AM-50BAE	A	208	(PTC relay)	None	1	None
AM-50BAE	B	209	(PTC relay)	None	1	None
KM-61BAH	C	210	(PTC relay)	None	1	None
KM-101BAH, KM-151BAH	C	210	100	None	1	None
KM-201BAH, KM-260BAH	D	211	260	None	1	6
KML-250MAH/MWH	E	212	72~88	20	None	None
KM-251BAH/BWH, KM-255BAH/BWH	F	213	410	None	1	5
KM-280MAH/MWH	G	214	378~445	None	5.5	5
KM-280MAH-E, KM-500MAH-E	H	215	72~86	15	5.5	2.5
KM-320MAH/MWH	I	216	72~86	20	5.5	5
KML-350MAH/MWH	E	212	243~292	15	None	None
KML-351MAH/MWH Serial S & Before	E	212	72~88	20	None	5



## KM Wiring Diagram Reference Chart:

Note: All capacitor values are in MFD.

Model	Wiring Diagram	Page	Start Capacitor	Run Capacitor	Pump Capacitor	Fan Capacitor
KML-351MAH/MWH Serial T & After, KML-451MAH/MWH	E	212	243~292	15	None	5
KMD-410MAH	J	217	243~292	35	2.5	5
KML-450MAH/MWH	E	212	189~277	25	None	5
KMD-450MAH/MWH	K	218	243~292	35	2.5	6
KMD-460M_H, KMD-530M_H	M	220	243~292	35	2.5	6
KM-461MRH	N	221	243~292	15	5.5	10
KM-461MAH/MWH	I	216	243~292	15	5.5	5
DKM-500BAH Serial UxxxxxA and Before	L	219	189~227	25	None	5
DKM-500BAH Serial UxxxxxJ and After	L	219	243~292	35	2.5	5
KM-501MAH/MWH	I	216	72~86	25	5.5	5
KM-515MAH/MWH, KM-600MAH	I	216	243~292	35	5.5	5
KM-501MRH	N	221	77~86	25	5.5	5
KM-515MRH	N	221	243~292	35	5.5	5

## KM Wiring Diagram Reference Chart:

Note: All capacitor values are in MFD.

Model	Wiring Diagram	Page	Start Capacitor	Run Capacitor	Pump Capacitor	Fan Capacitor
KML-600M_H, KML-631MAH/MWH	O	222	145~174	30	None	5
KM-630MAH/MWH	P	223	88~108	15	5.5	5
KM-630MRH	Q	224	88~108	15	5.5	10
KM-650MAH/MWH	P	223	175~216	25	5.5	5
KM-650MRH	Q	224	175~216	25	5.5	10
KM-630MAH-E, KM-650MAH-E	R	225	88~108	None	5.5	2.5
KMD-700MAH/MWH, KMD-850MAH/MWH, KMD-901MAH/MWH	S	226	145~174	30	10	5
KMD-700MRH, KMD-850MRH, KMD-901MRH	T	227	145~174	30	10	10
KMS-750MLH w/SRK-7H	U	228	145~174	30	10	10
KMS-822MLH w/SRK-10H	V	229	145~174	30	10	10
KMS-830MLH w/SRK-8H(3)	W	230	145~174(Non)	30(Non)	10	10
KM-900MAH/MWH	P	223	145~174	35	5.5	5
KM-900MRH3, KM-901MRH3	X	231	None	None	5.5	10

## KM Wiring Diagram Reference Chart:

Note: All capacitor values are in MFD.

Model	Wiring Diagram	Page	Start Capacitor	Run Capacitor	Pump Capacitor	Fan Capacitor
KM-901MAH/MWH	P	223	145~174	30	5.5	5
KM-900MRH	Q	224	145~174	35	5.5	10
KM-901MRH	Q	224	145~174	30	5.5	10
KMD-900MAH/MWH	S	226	145~174	35	10	5
KMD-900MRH	T	227	145~174	35	10	10
KMS-1122MLH w/SRK-12H(30)	Y	232	145~174(None)	35(None)	10	10
KMS-1230MLH w/SRK13H, KMS-1400MLH w/SRK14H(3)	U	228	145~174(None)	35(None)	10	10
KMS-1401MLJ w/SRK-14J/3	U	228	189~227 (None)	35(None)	10	10
KM-1300SAH, KM-1300SWH KM-1300MWH, KM-1340MAH/MWH, KM-1601SWH	Z	233	145~174	35	10	5
KM-1300SAH3, KM-1300SWH3	AA	234	None	None	10	5
KM-1300SRH3	BB	235	None	None	10	10
KM-1301SAH	CC	236	145~174	35	10	5
KM-1301SWH	CC	236	145~174	30	10	None

## KM Wiring Diagram Reference Chart:

Note: All capacitor values are in MFD.

Model	Wiring Diagram	Page	Start Capacitor	Run Capacitor	Pump Capacitor	Fan Capacitor
KM-1301SAH3, KM-1301SWH3	Serial U0 and Before	237	None	None	10	5
KM-1301SAH3, KM-1301SWH3	Serial U1 and After	238	None	None	10	5
KM-1301SRH	Serial U0 and Before	239	145~174	30	10	10
KM-1301SRH	Serial U1 and After	240	145~174	30	10	10
KM-1301SRH3	Serial U0 and Before	241	None	None	10	10
KM-1301 SRH3	Serial U1 and After	242	None	None	10	10
KM-1300SRH, KM-1340MRH, KM-1601SRH, KM-1601MRH	JJ	243	145~174	35	10	10
KM-1300MAH, KM-1800SAH, KM-1900SAH	MM	246	145~174	35	10	5
KMS-1400MLH w/SRK-14H(3)	KK	244	None	None	10	10
KM-1600SRH3, KM-1600SWH3	LL	245	None	None	10	10
KM-1600MRH3, KM-1601MRH3						
KM-1600SWH	Z	237	189~227	40	10	none

## KM Wiring Diagram Reference Chart:

Note: All capacitor values are in MFD.

Model	Wiring Diagram	Page	Start Capacitor	Run Capacitor	Pump Capacitor	Fan Capacitor
KM-1600SRH, KM-1600MRH	JJ	243	189~227	40	10	10
KM-1600MRH3/SRH3, KM-1601MRH3/SRH3 KM-1800SWH3/SRH3, KM-1900SWH3/SRH3 KM-2000SWH3/SRH3	NN	247	None	None	10	10
KM-1800SWH, KM-1800SRH	OO	248	145~174	35	10	10
KM-1800SAH3, KM-1900SAH3	PP	249	None	None	10	5
KM-1900SAH	MM	246	189~227	35	10	5
KM-1900SWH, KM-1900SRH	OO	248	189~227	35	10	10
KMS-2000MLH w/SRK-20H(3)	QQ	250	189~227(Non)	40(Non)	10	10
KM-2000SWH3/SRH3, KM-2100SWH3/SRH3	RR	251	None	None	10	10
KM-2400SRH3	RR	251	None	None	15	15
KM-2500SWH/SRH (3)	RR	251	None	None	10	10
KMS WIRING HARNESS	SS	252	N/A	N/A	N/A	N/A

## Remote Condenser Capacitor Chart

Note: All capacitors values are in MFD.

Model	Start Capacitor	Run Capacitor	Fan Capacitor	Number of Fan Capacitors
URC-5F/6F/7F/9F	-	-	10	1
URC-12F/14F/20F/21F/22F/23F	-	-	10	2
URC-24F	-	-	15	4
SRK-7H	145~174	30	10	2
SRK-8H(3)	145~174(None)	30(None)	10	1
SRC-10H	145~174	30	10	2
SRK-12H(3)	145~174(None)	30(None)	10	1
SRK-13H/14H	145~174	35	10	2
SRK-14J	189~227	35	10	2
SRK-14H3, SRK-14J3	None	None	10	2
SRK-20H(3)	189~227(None)	40(None)	10	2

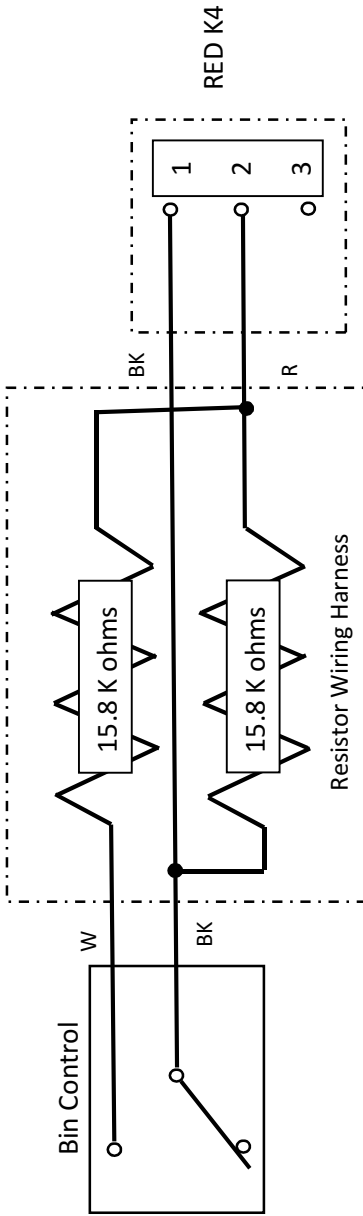

**MECHANICAL BIN CONTROL OPERATION:**

The mechanical bin control is included on some models. The mechanical assembly is located in the ice drop zone area .

When the actuator paddle is in the normal (Bin Empty) position, the bin control proximity switch will close. On E board models,

1. When the switch contacts close, 7.6 K Ohms of resistance is supplied to the K4 board connector.

2. When ice pushes the paddle to the full right position (Bin Full), the proximity switch opens as shown above and will supply 15.8 K Ohms to the K4 board connector.

For G Board models, resistors are not used. The switch will close to start the unit and open to stop the unit.

# A AM-50BAE

## Original control board, serial C-0 and earlier.

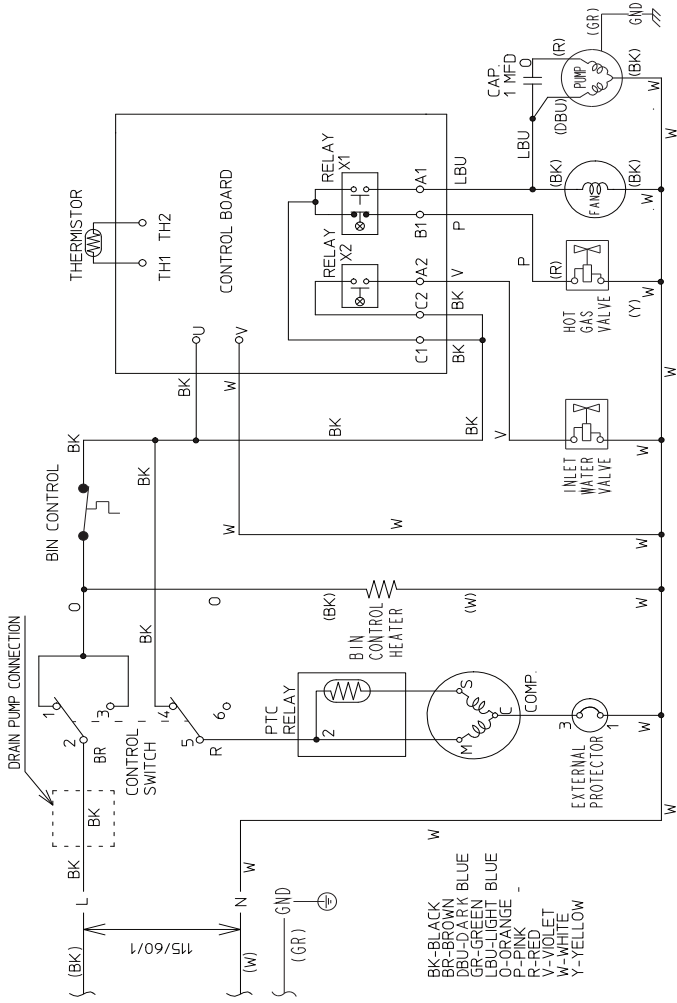



# B

## AM-50BAE

### New control board, serial C-1 and after.

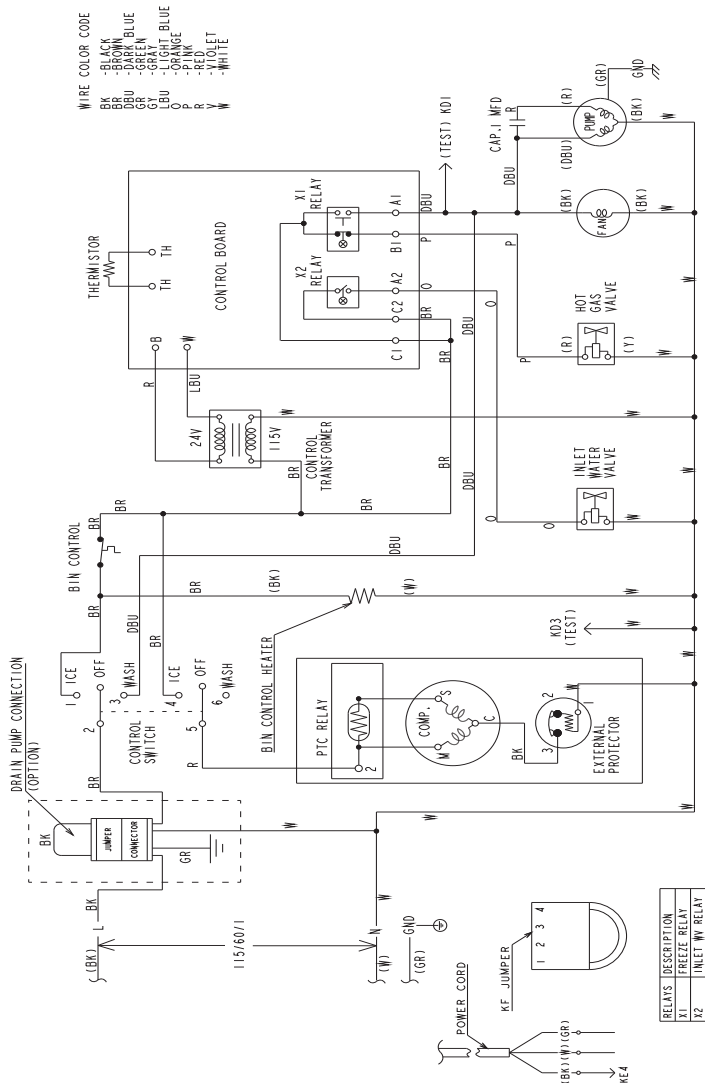

# C

## KM-61BAH, KM-101BAH, KM-151BAH

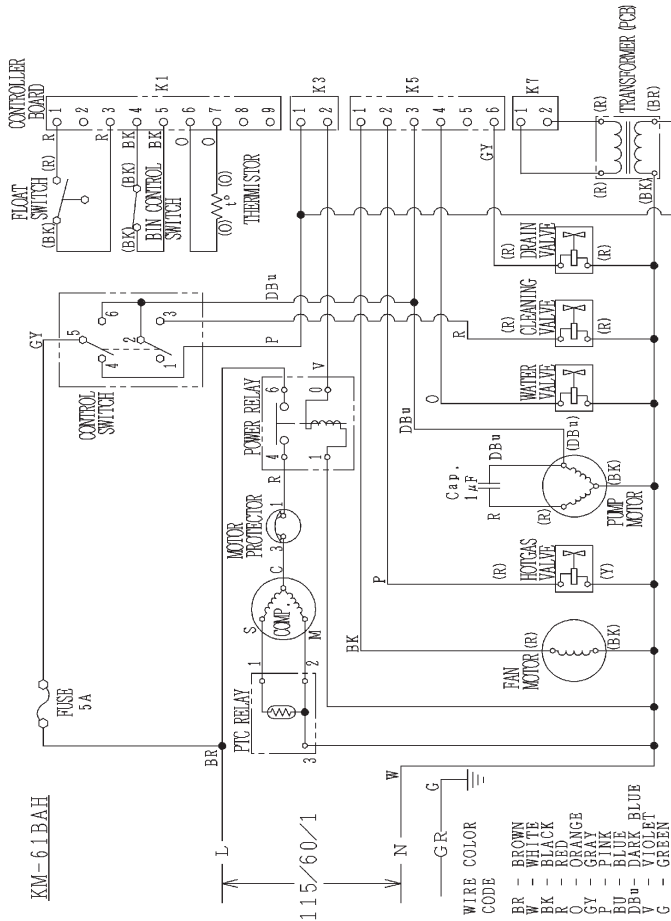

**Note:**

1. KM-61BAH uses PTC Relay for compressor.
2. Pressure switch used on KM-151BAH model only.  
Cut-out: 355+/-21 psig  
Cut-in: 270+/-21 psig
3. See wiring diagram chart for capacitor ratings.

# D

## KM-201BAH, KM-260BAH

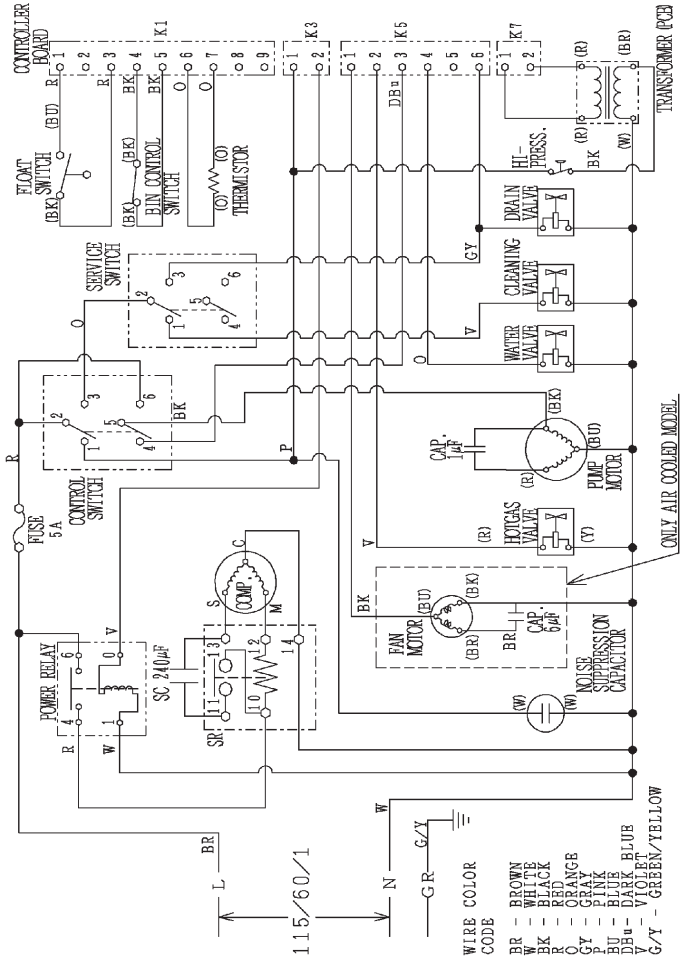

# E

## KML-250MAH/MWH, KML-350MAH/MWH, KML-351MAH/MWH, KML-450MAH/MWH, KML-451MAH/MWH

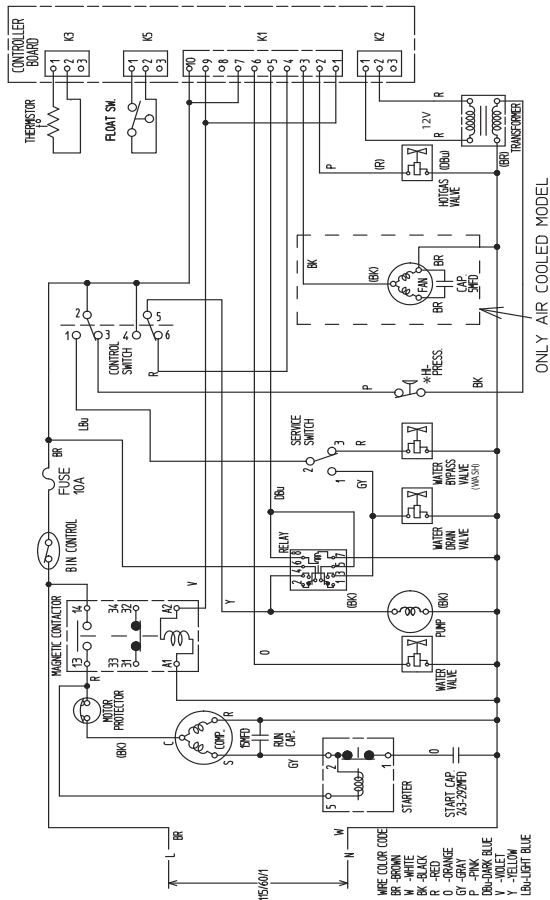

* Pressure Switch		
	Air-Cooled Model	Water-Cooled Model
Cut-out	412± <sup>21.3</sup> <sub>0</sub> PSIG	384± <sup>21.3</sup> <sub>0</sub> PSIG
Cut-in	327±21.3 PSIG	284±21.3 PSIG

- Note:**
1. Some models use mechanical bin control instead of thermostatic bin control with fuse as shown.
  2. Generic Diagram: See unit service manual or wiring diagram chart for capacitor ratings by model.

# F

## KM-251BAH/BWH, KM-255BAH/BWH

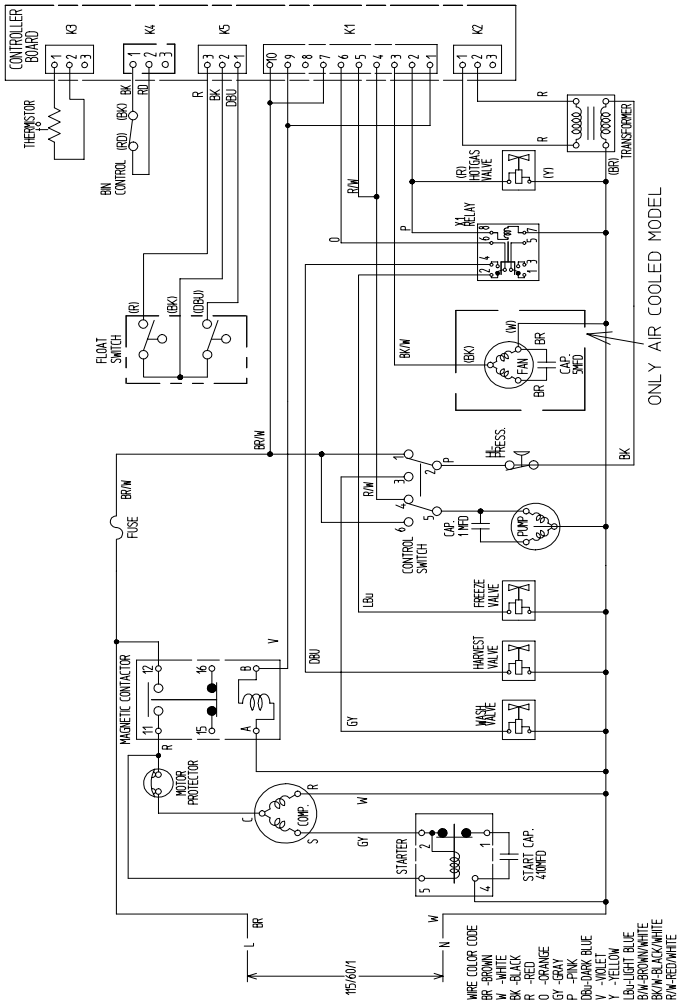

3A3443-011

# G

## KM-280MAH/MWH

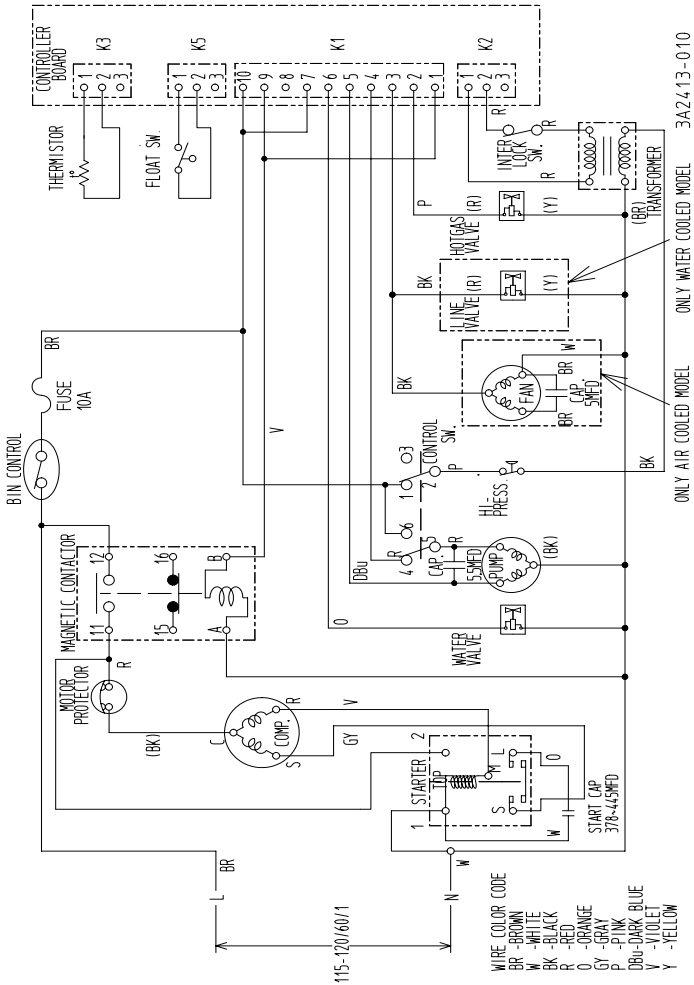

- Note:**
1. Some models use mechanical bin control instead of thermostatic bin control with fuse as shown.
  2. Generic Diagram: See unit service manual or wiring diagram chart for capacitor ratings by model.

# H

## KM-280MAH-E, KM-500MAH-E, KM-630MAH-E

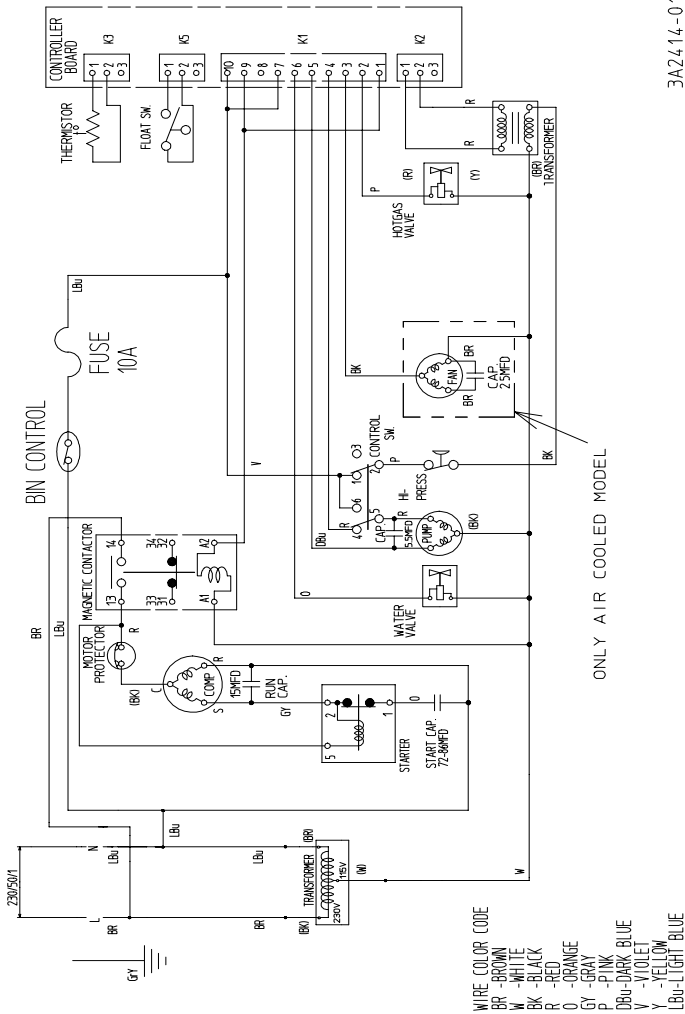

WIRE COLOR CODE  
 BR - BROWN  
 N - WHITE  
 BK - BLACK  
 R - RED  
 O - ORANGE  
 GY - GRAY  
 P - PINK  
 DBU - DARK BLUE  
 V - VIOLET  
 Y - YELLOW  
 LBU - LIGHT BLUE

- Note:**
1. Some models use mechanical bin control of thermostatic bin control with fuse as shown.
  2. Generic Diagram: KM-630MAH-E Has 88~108MFD start capacitor and no run capacitor.

# I

## KM-320MAH/MWH, KM-461MAH/MWH, KM-501MAH/MWH, KM-515MAH/MWH, KM-600MAH

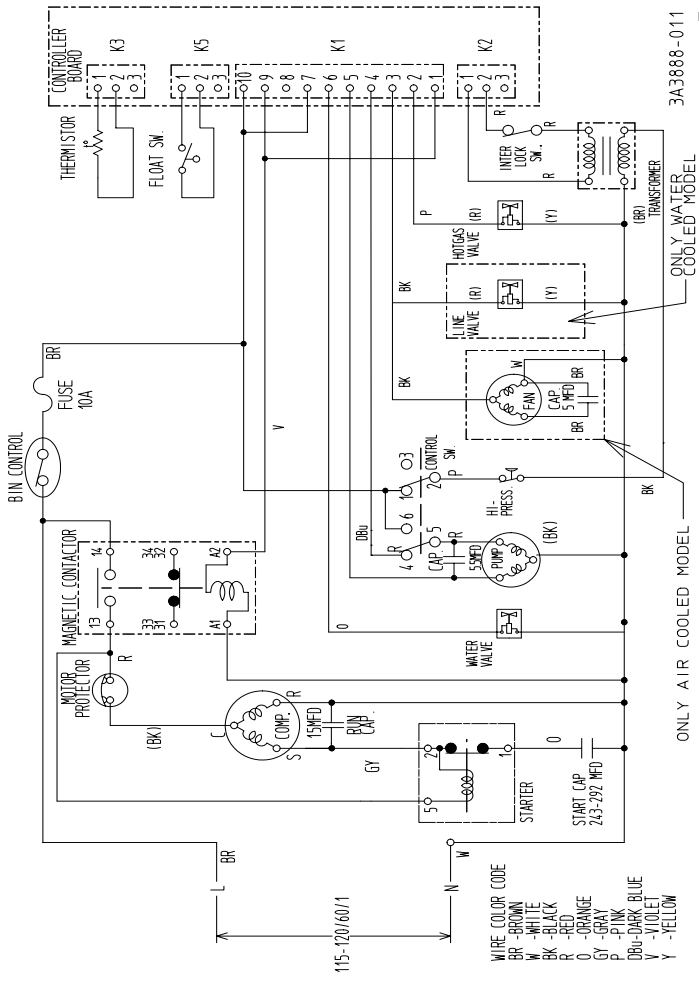

- NOTE: 1. Generic diagram: See unit serv manual or wiring diag chart for cap ratings by model.  
 2. Production of KM-320/515M after Feb 09 uses G board and mechanical bin control with no resistors in wiring harness.  
 3. Line Valve is also used on KM-461/515 air and KM501/515 remote.



# J KMD-410MAH/MWH

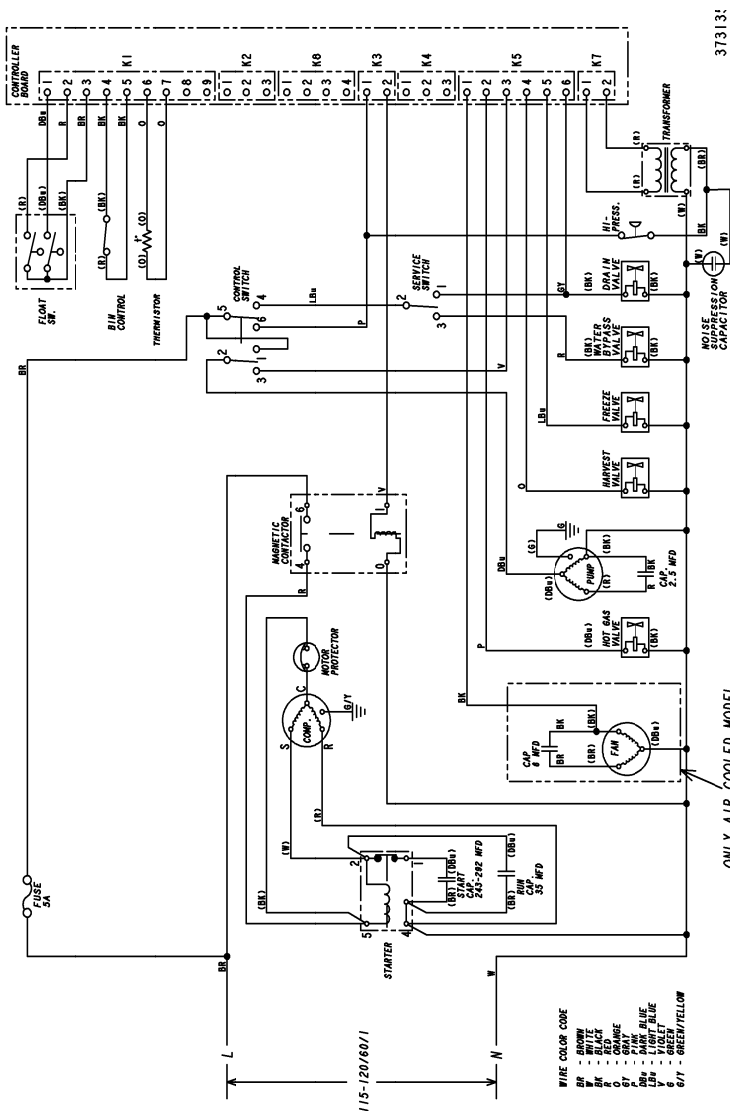

# K KMD-450MAH/MWH

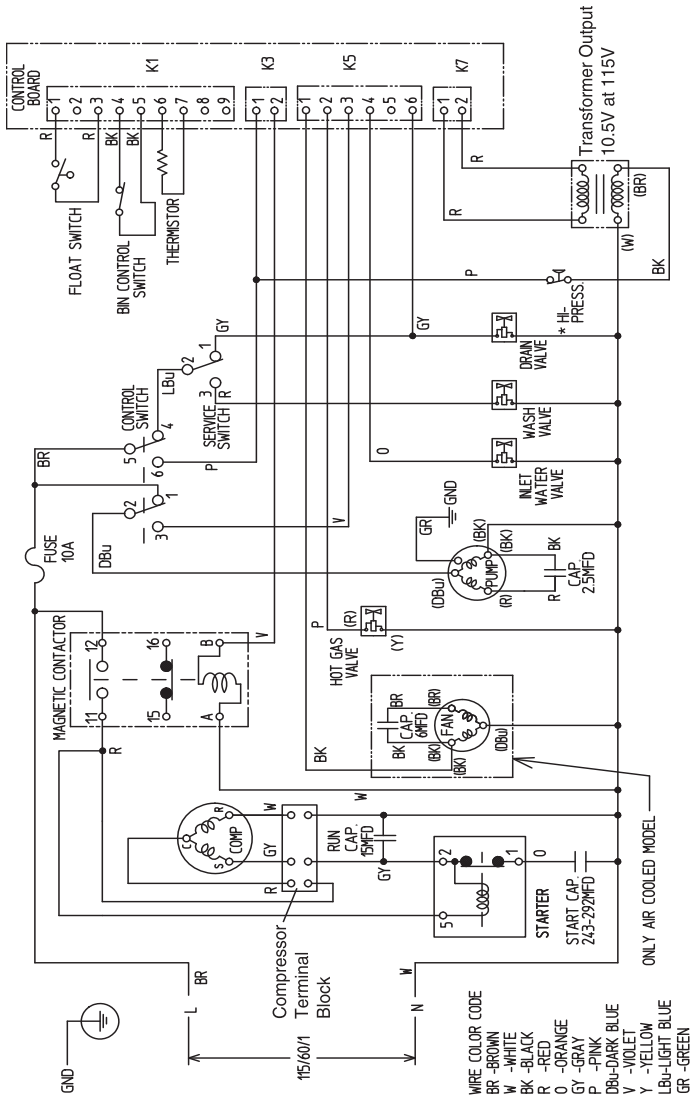

# L DKM-500BAH

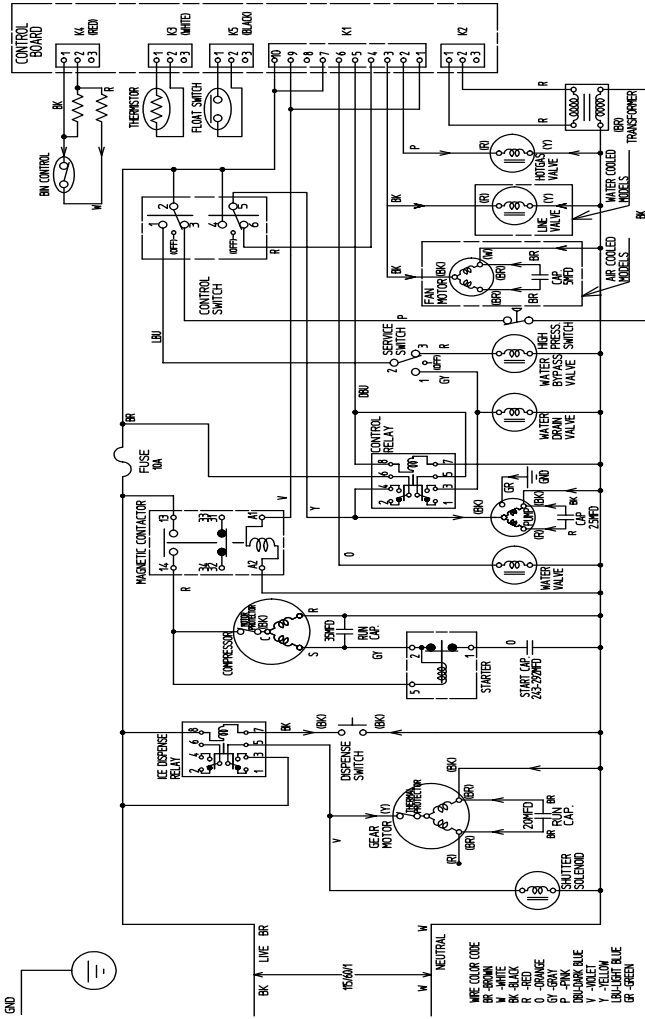

**Note:** DKM-500BAH units with serial UxxxxxA and before have a single winding pump motor without a capacitor, 189~227MFD start and 25MFD run capacitor.

M  
**KMD-460MAH/MWH, KMD-530M\_H**

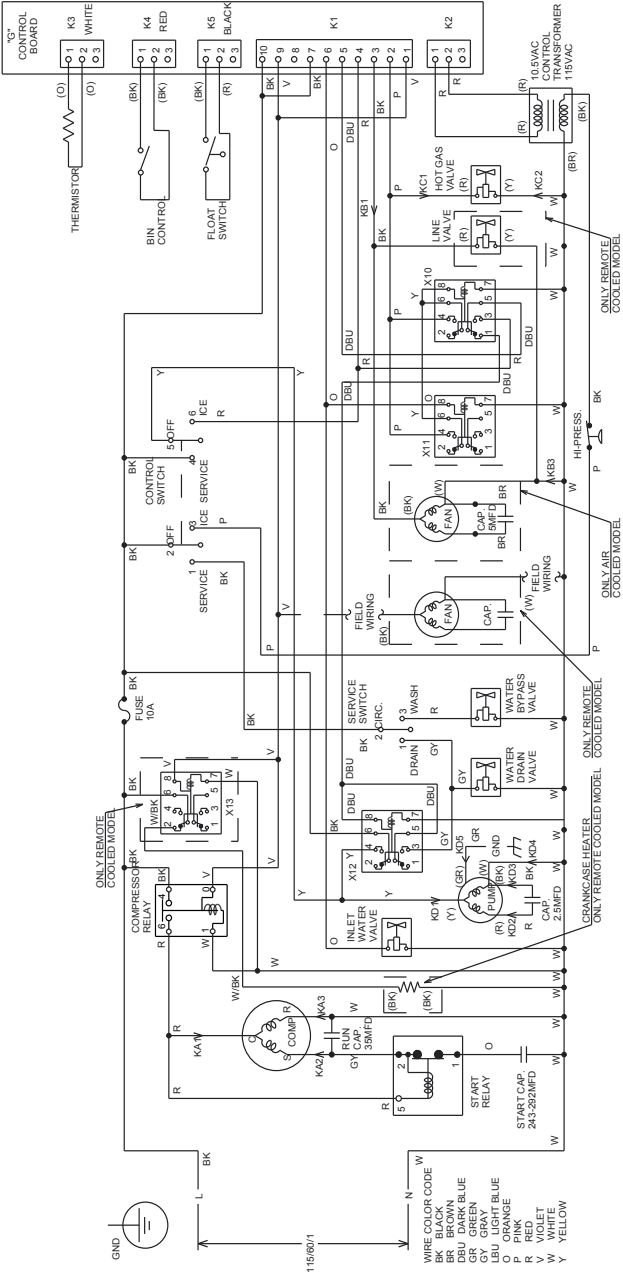

# N

## KM-461MRH, KM-501MRH, KM-515MRH

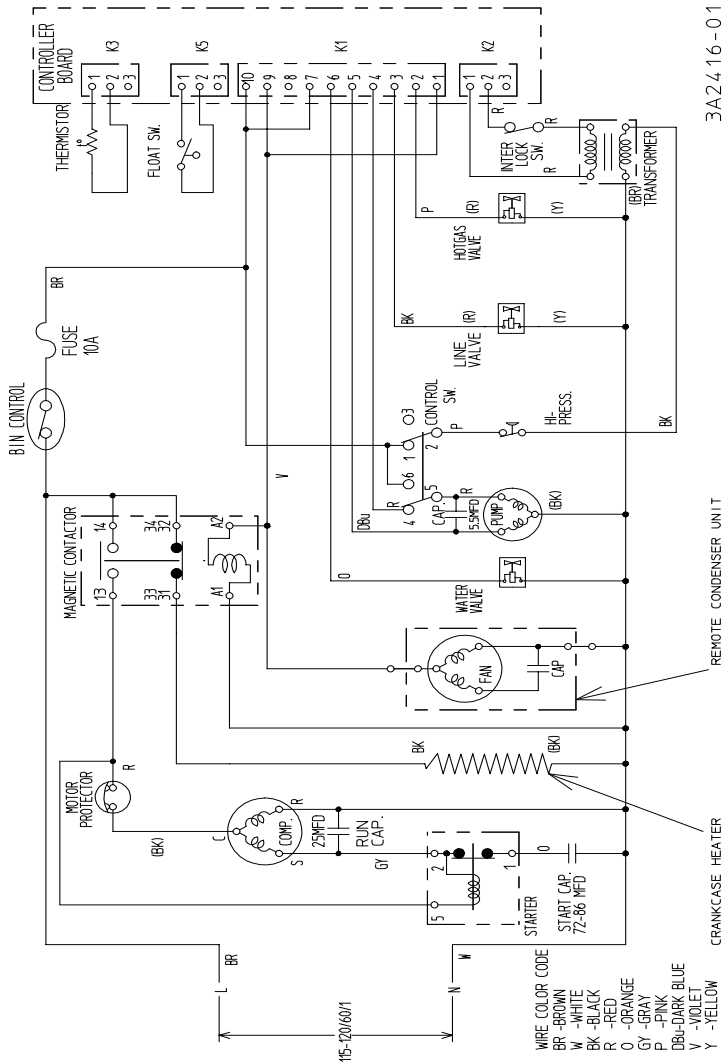

NOTE: Generic diagram.  
 KM-501MRH has 25MFD run capacitor.  
 KM-501 has 243~292MFD start and 35 MFD run capacitor.

# O

## KML-600MAH/MWH/MRH, KML-631MAH/MWH

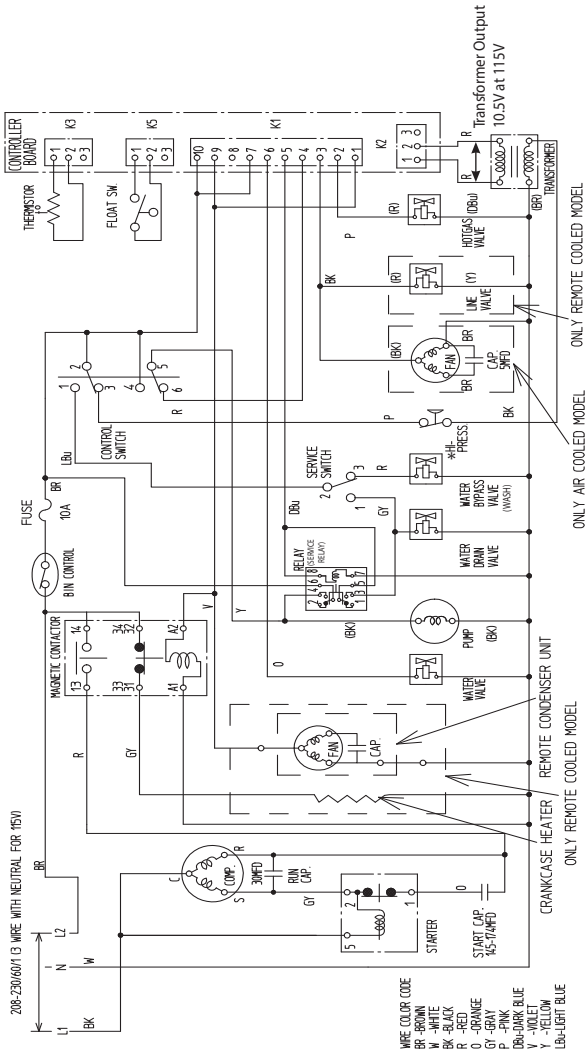

- Note:** 1. Some models use mechanical bin control instead of thermostatic bin control with fuse as shown.
2. Generic Diagram: See unit service manual or wiring diagram chart for capacitor ratings.

# P

## KM-630MAH/MWH, KM-650MAH/MWH, KM-900MAH/MWH, KM-901MAH/MWH

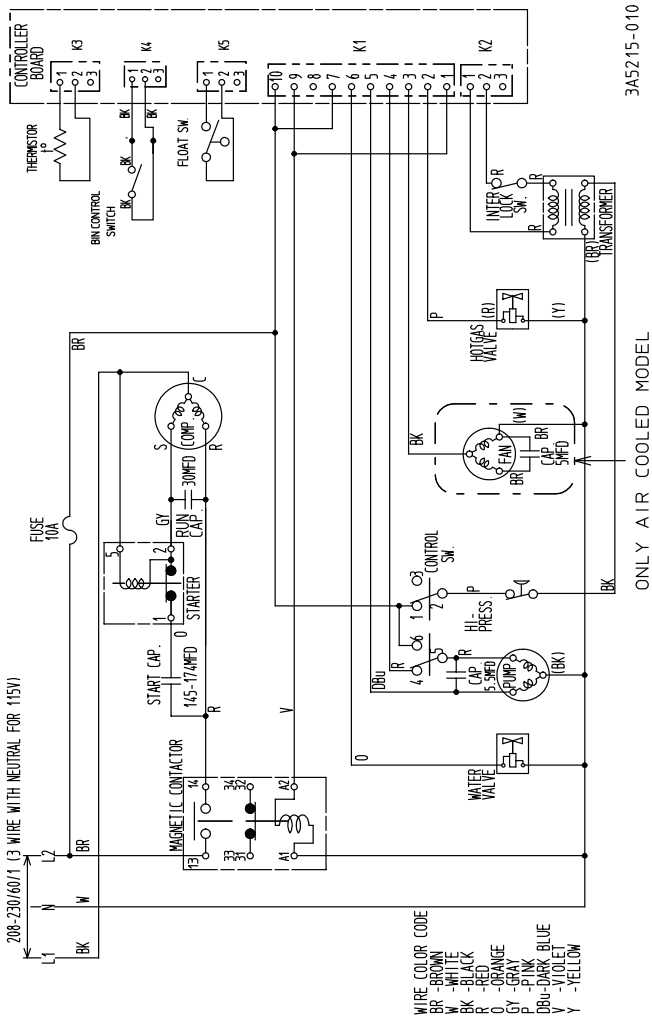

- Note:**
1. Some production models will include thermostatic bin control with fuse instead of mechanical bin control as shown.
  2. Generic diagram: See unit, service manual or wiring diagram chart for capacitor ratings by model.
  3. Production after February 09 uses G board and mechanical bin control with no resistors in wiring harness.

# Q

## KM-630MRH, KM-650MRH, KM-900MRH, KM-901MRH

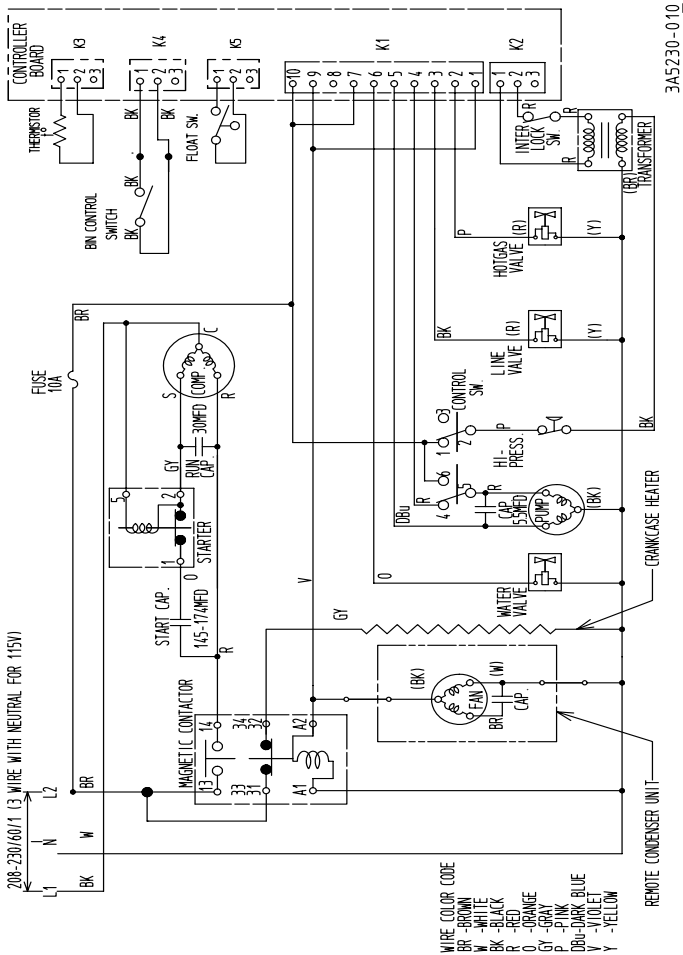

- Note:**
1. Generic diagram: See unit, service manual or wiring diagram for capacitor ratings by model.
  2. Some production models will include mech BC instead of thermostatic BC.
  3. Later production after February 09 uses G board and mech BC with no resistors in wiring harness.
  4. KM-900MRH before M2 have different numbering on contactor but wiring remains the same.



# R

## KM-630MAH-E, KM-650MAH-E

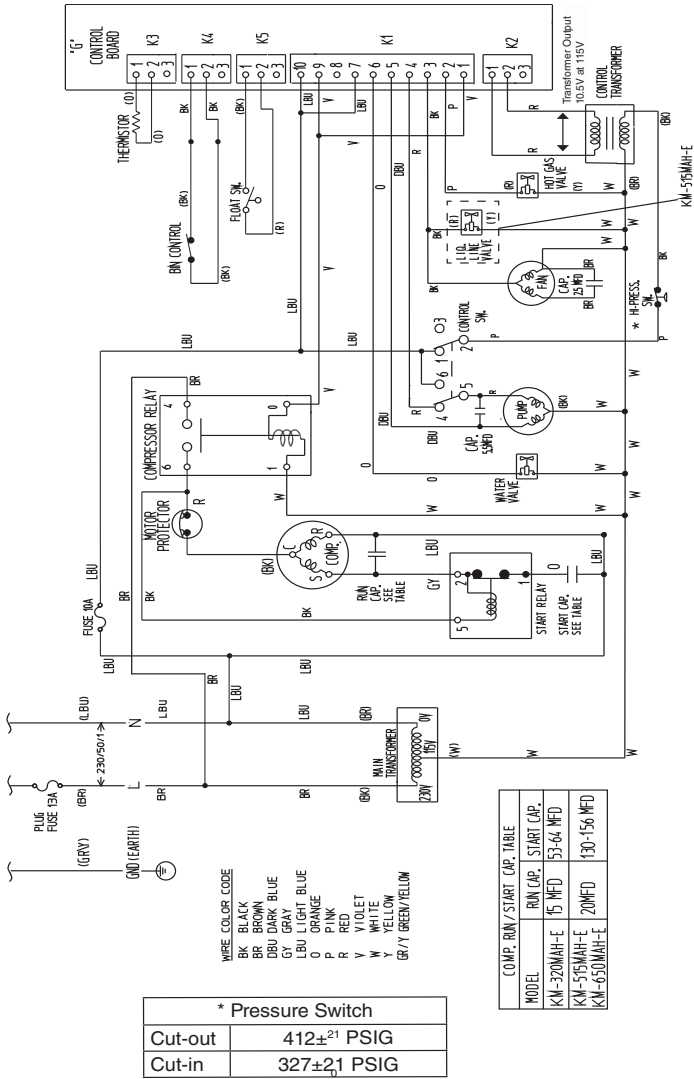

Note: KM-650MAH-E G board diagram.

1. Prior production may have thermostatic bin control in series with fuse.
2. KM-630MAH-E uses E Board and resistor wire on mechanical control K4 connector.

# S

## KMD-700MAH/MWH, KMD-850MAH/MWH, KMD-900MAH/MWH, KMD-901MAH/MWH

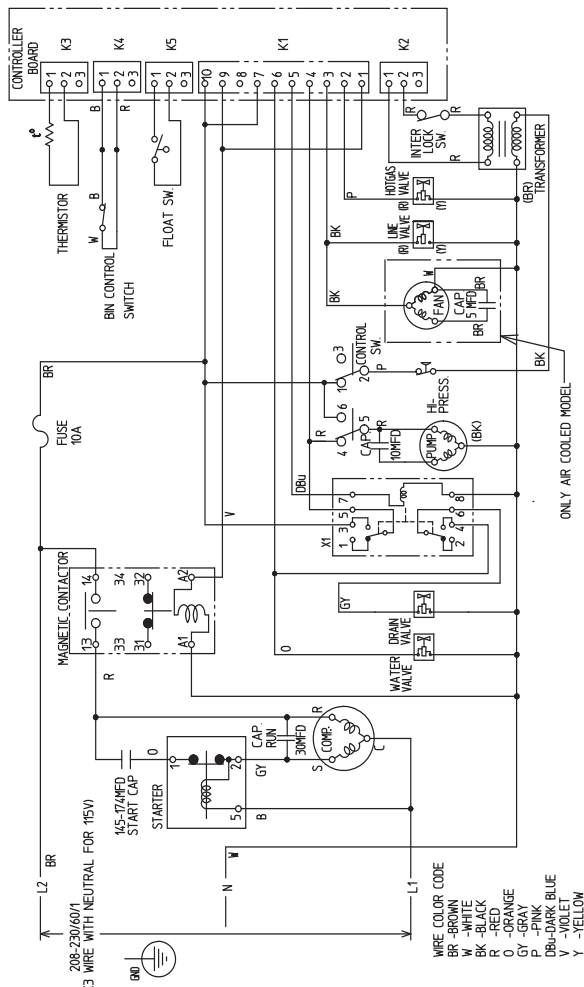

- Note:** 1. Generic diagram: KMD-900M has 35MFD run capacitor.  
 2. Line valve only used on KMD-901M  
 3. KMD-700/900M use E board and resistor wiring harness.

# T

## KMD-700MRH, KMD-850MRH, KMD-900MRH, KMD-901MRH

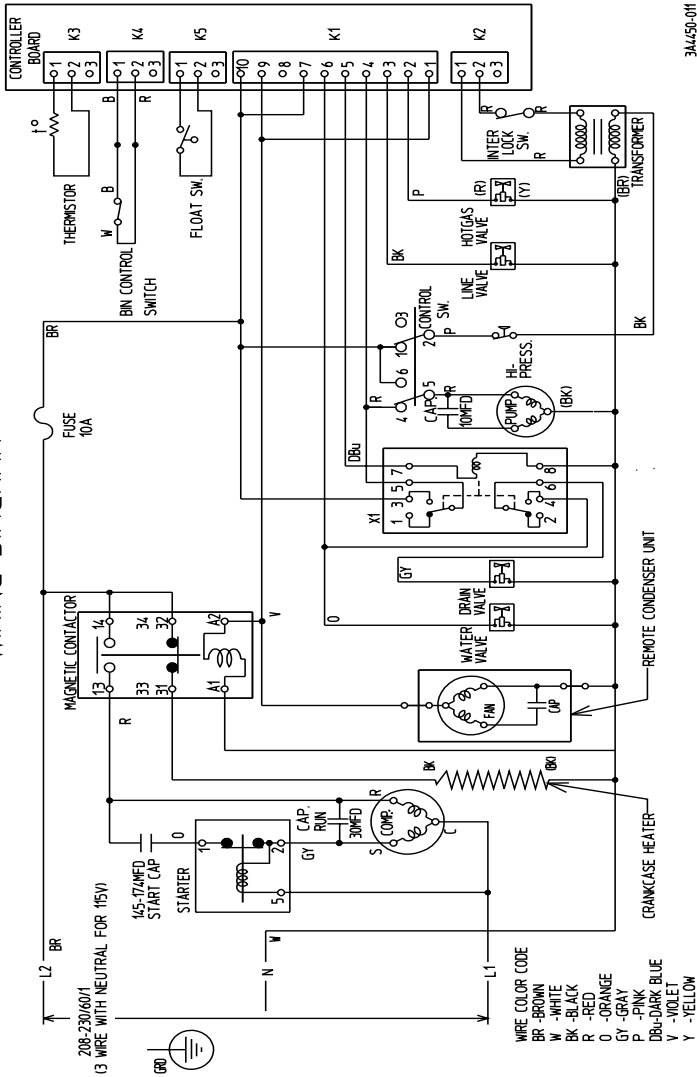

104750-01

**Note:** Generic diagram:

1. KM-900MRH has 30MFD run capacitor.
2. KMD-700/900M use E board and resistor wiring harness.

# U

## KMS-750MLH&SRK-7H, KMS-1230MLH& SRK13H, KMS-1400MLH&SRK-14H, KMS- 1401MLH&SRK14H/H3, KMS-1401MLH& SRK-14J/J3

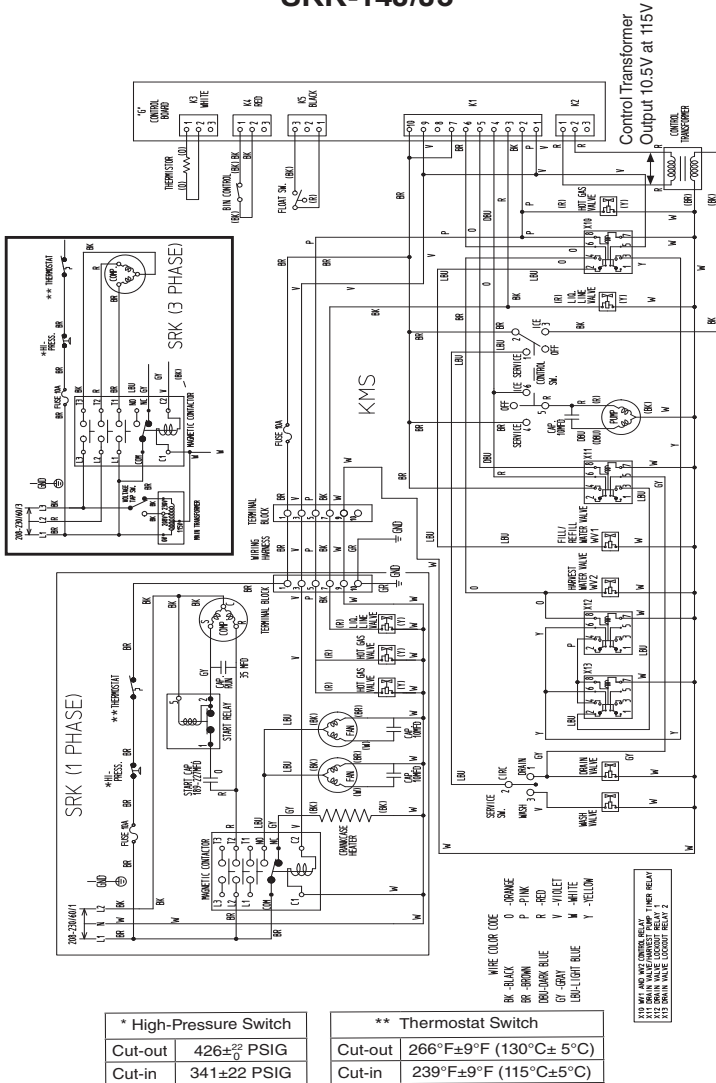

**Note:** Generic diagram.

SRK-7H uses 30MFD run capacitor.

SRK-14J has 2 HGV's, All other SRK's have 1 HGV.

Start capacitor on all but SRK-14J is 145~174MFD.

# V KMS-822MLH & SRK-10H

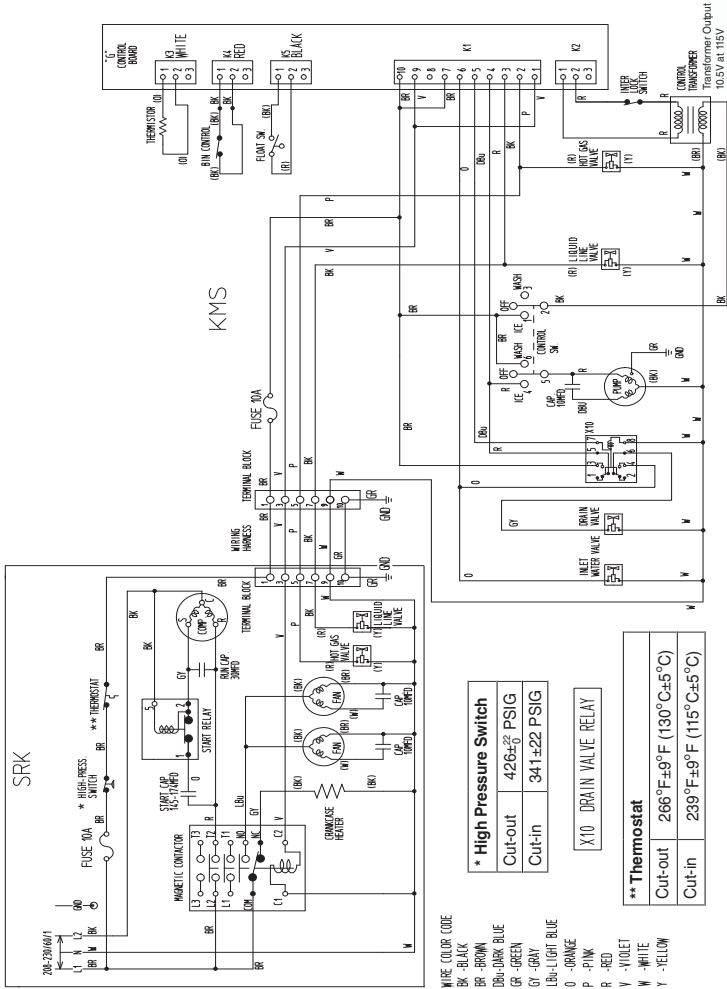

# W KMS-830MLH & SRK-8H

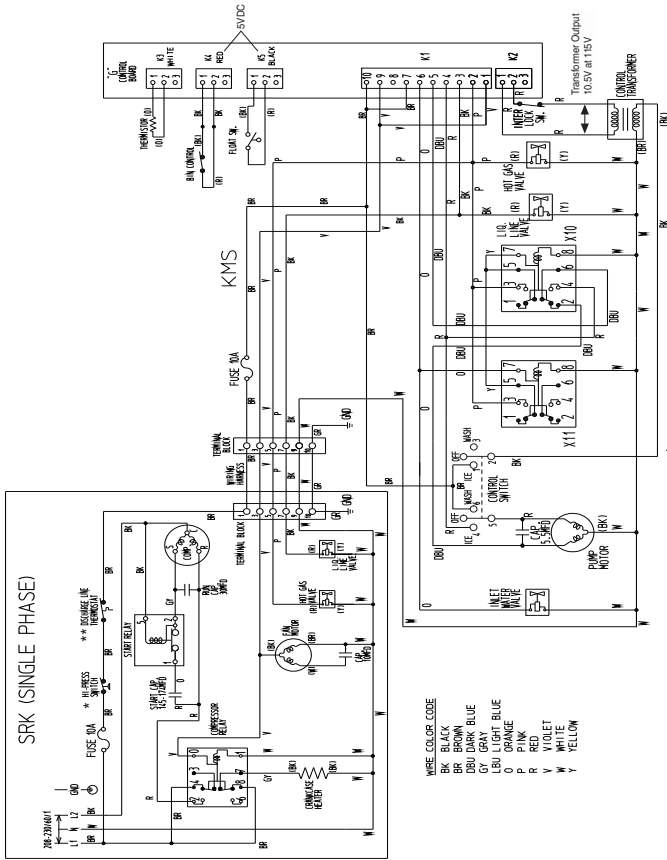

* High Pressure Switch	
Cut-out	426±2 <sup>°</sup> PSIG
Cut-in	341±22 PSIG

** Discharge Line Thermostat	
Cut-out	266°F±9°F (130°C±5°C)
Cut-in	239°F±9°F (115°C±5°C)

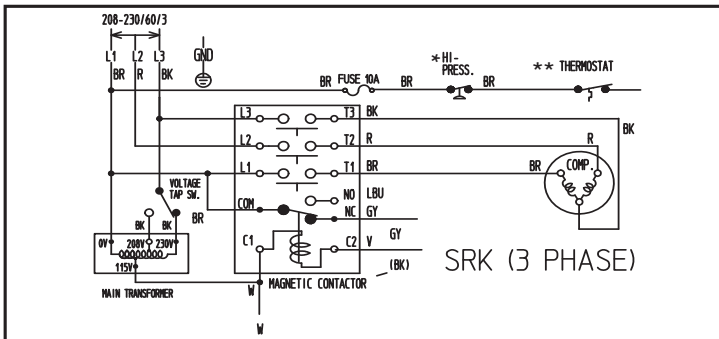

# X KM-900MRH3, KM-901MRH3

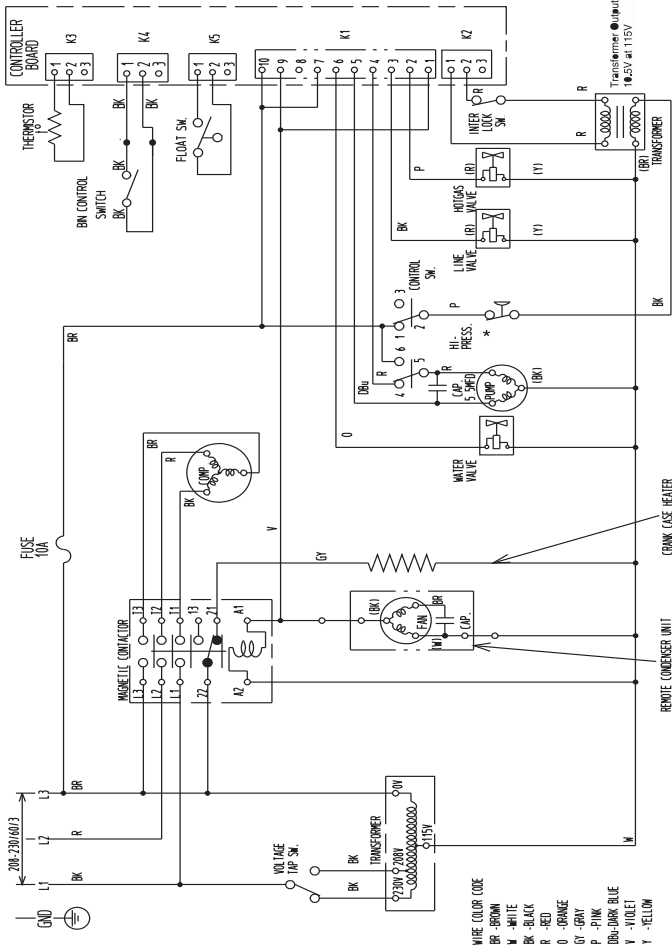

- Note:**
1. Some models use thermostatic bin control with fuse instead of mechanical bin control as shown.
  2. Production after February 09 uses G board and mech bin control with no resistors in wiring harness.

# Y KMS-1122MLH & SRK-12H/3

WIRE COLOR CODE  
 BR -BLACK  
 BU -BROWN  
 BLU -BLUE  
 GRN -GREEN  
 GR -GRAY  
 O -ORANGE  
 P -PINK  
 R -RED  
 V -VIOLET  
 W -WHITE

X10 PUMP MOTOR RELAY  
 X11 INLET WATER RELAY  
 X12 DRAIN VALVE RELAY

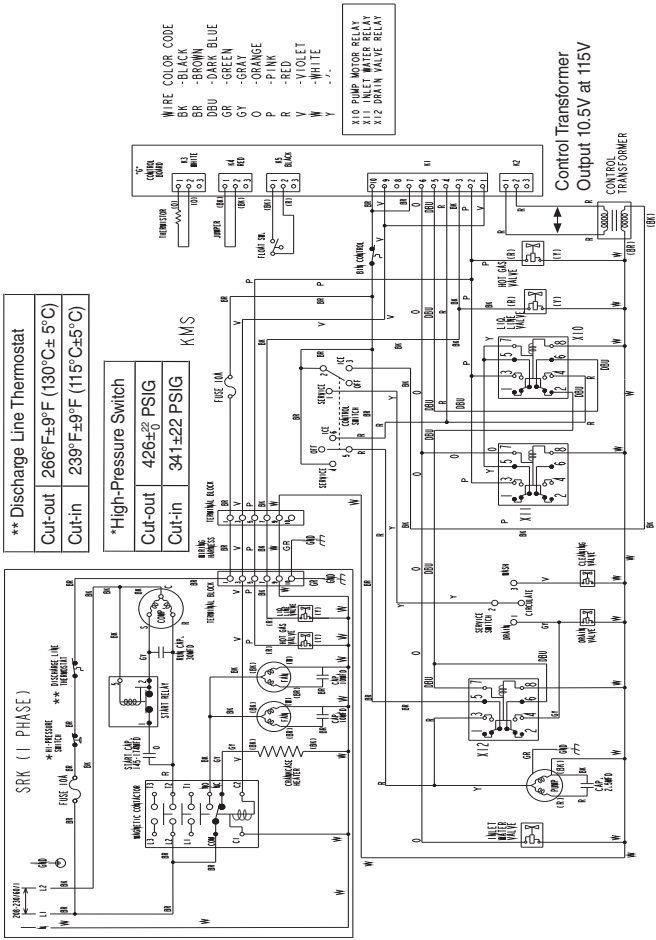

**\*\* Discharge Line Thermostat**  
 Cut-out | 266°F±9°F (130°C±5°C)  
 Cut-in | 239°F±9°F (115°C±5°C)

**\*High-Pressure Switch**  
 Cut-out | 426±2 PSIG  
 Cut-in | 341±2 PSIG

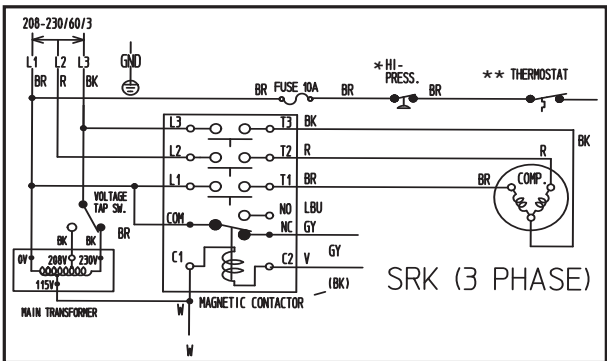
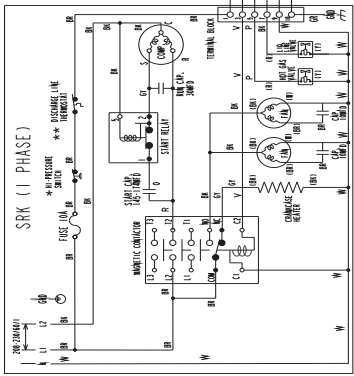



# Z

## KM-1300SAH, KM-1300SWH, KM-1300MWH, KM-1340MAH/MWH, KM-1600SWH, KM-1601SWH

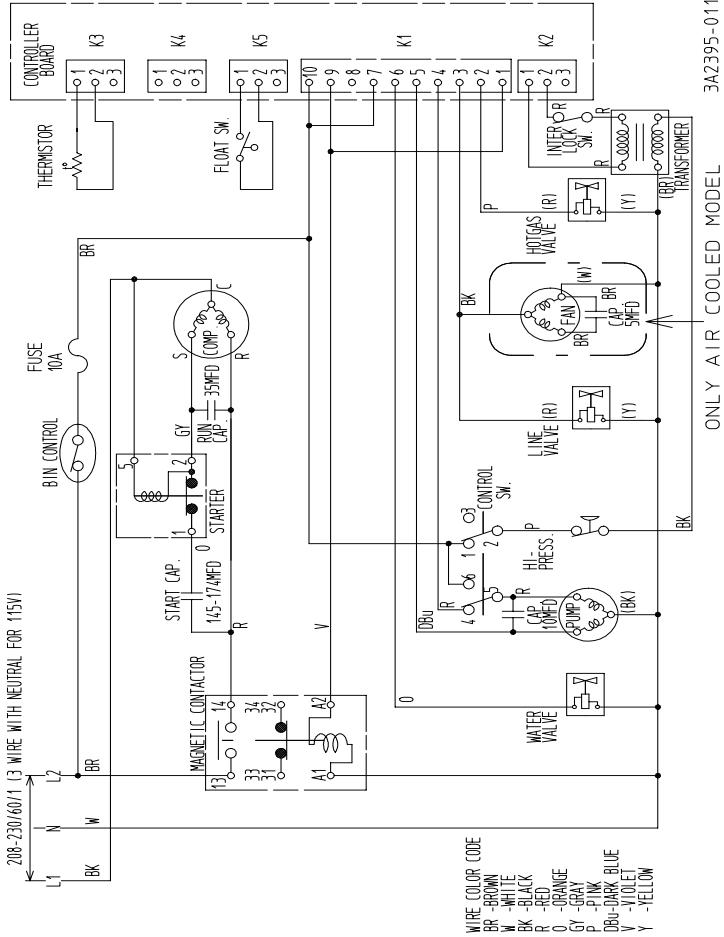

# AA

## KM-1300SAH3, KM-1300SWH3

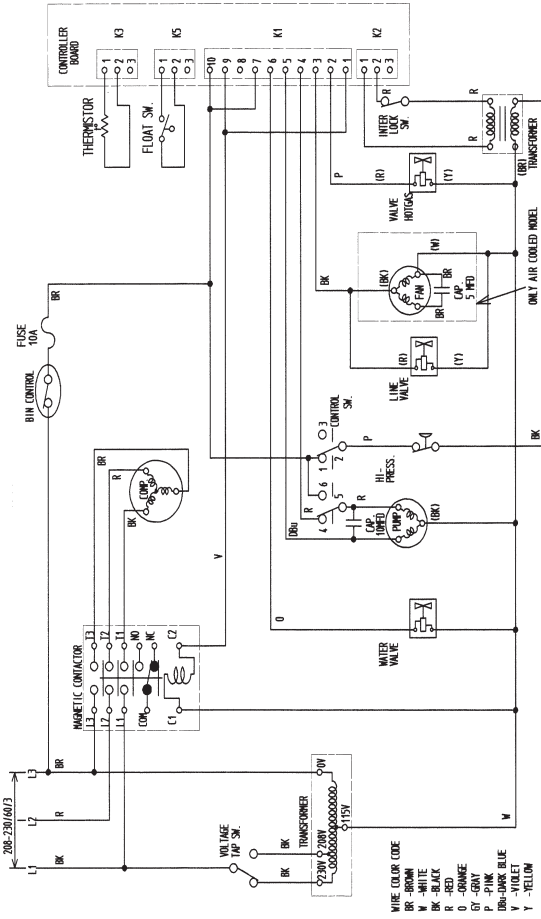

# BB KM-1300SRH3

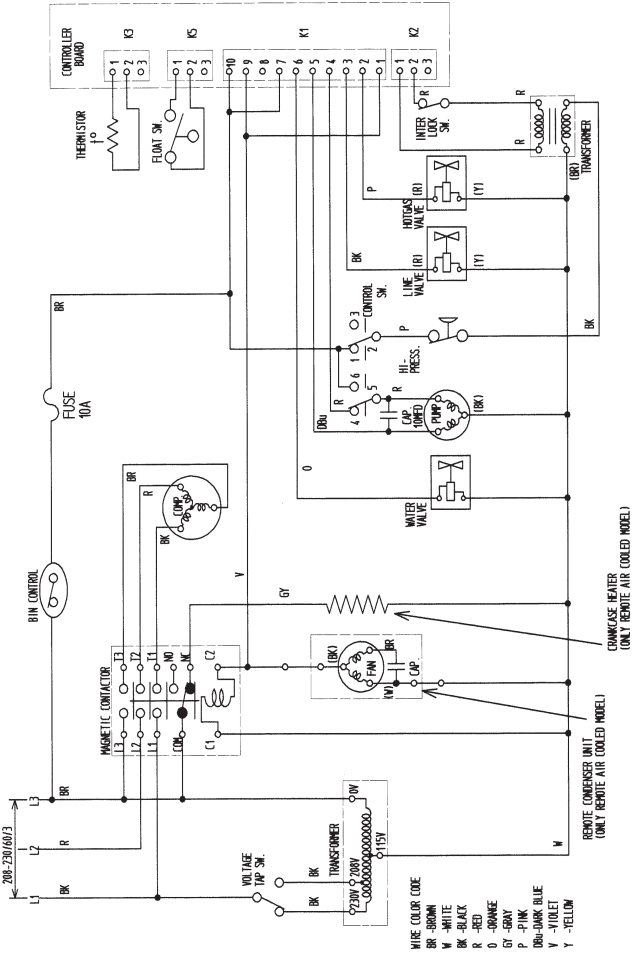



# DD KM-1301SAH3, KM-1301SWH3

Serial Code: U0 and before

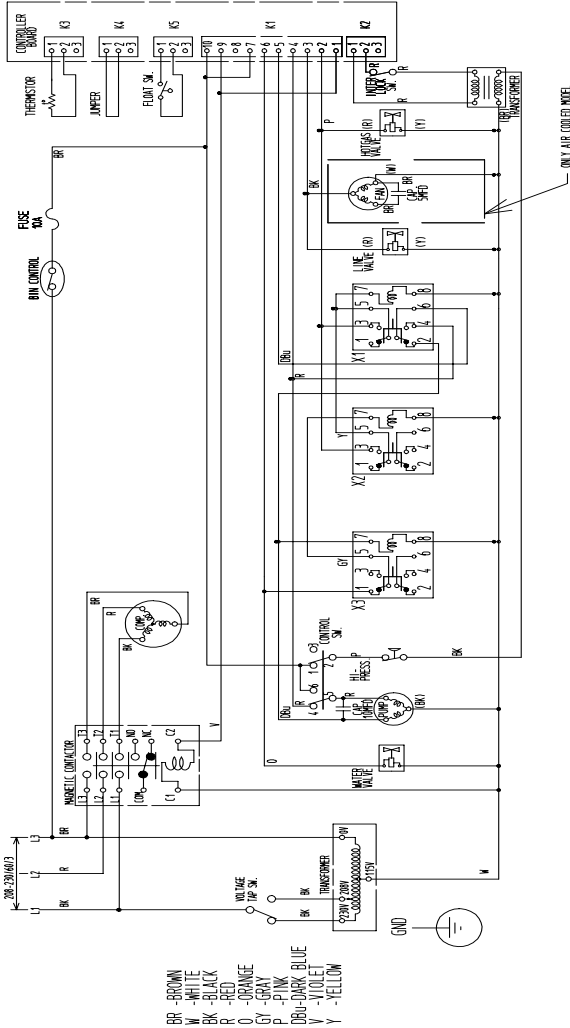

# EE KM-1301SAH3, KM-1301SWH3

Serial Code: U1 and after

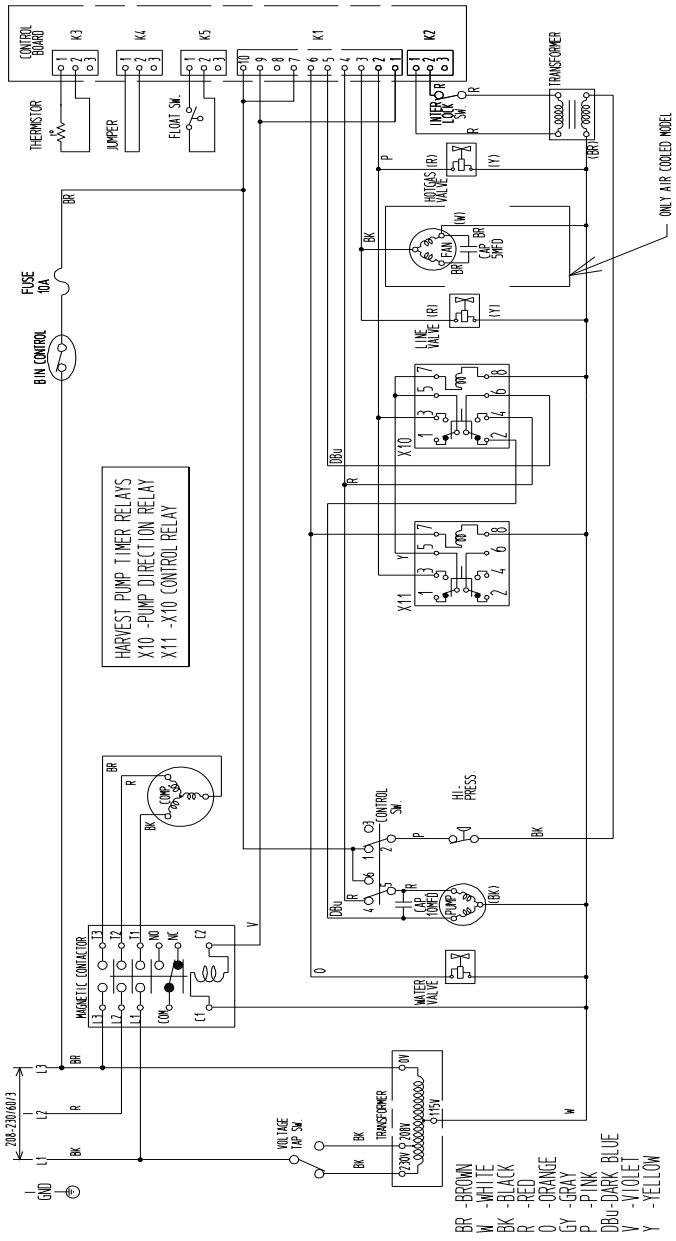

# FF KM-1301SRH

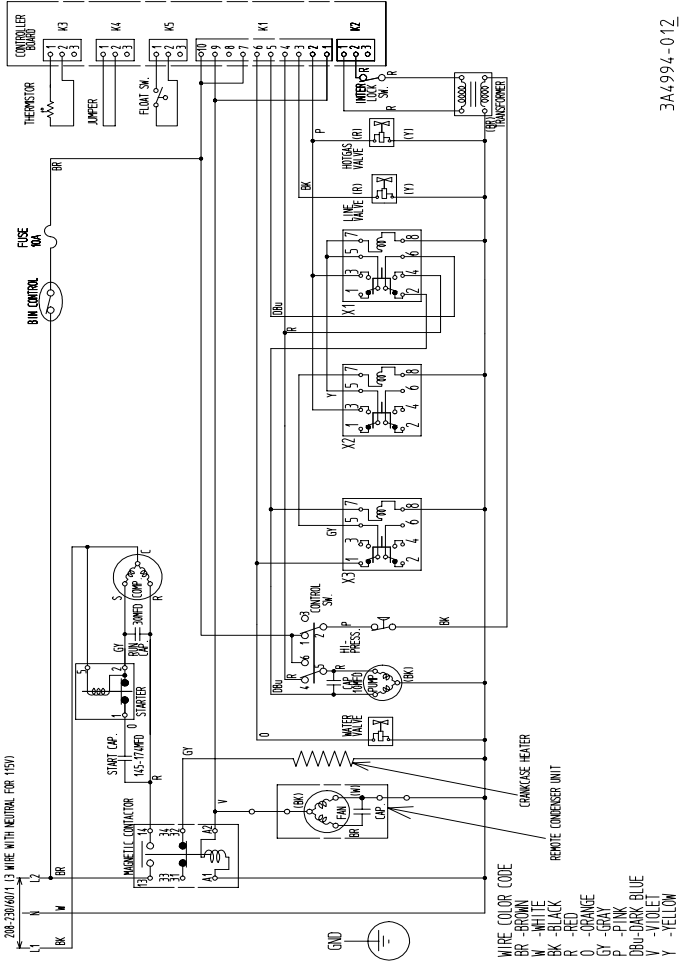

3A4994-01Z

# GG KM-1301SRH

Serial Code: U1 and after

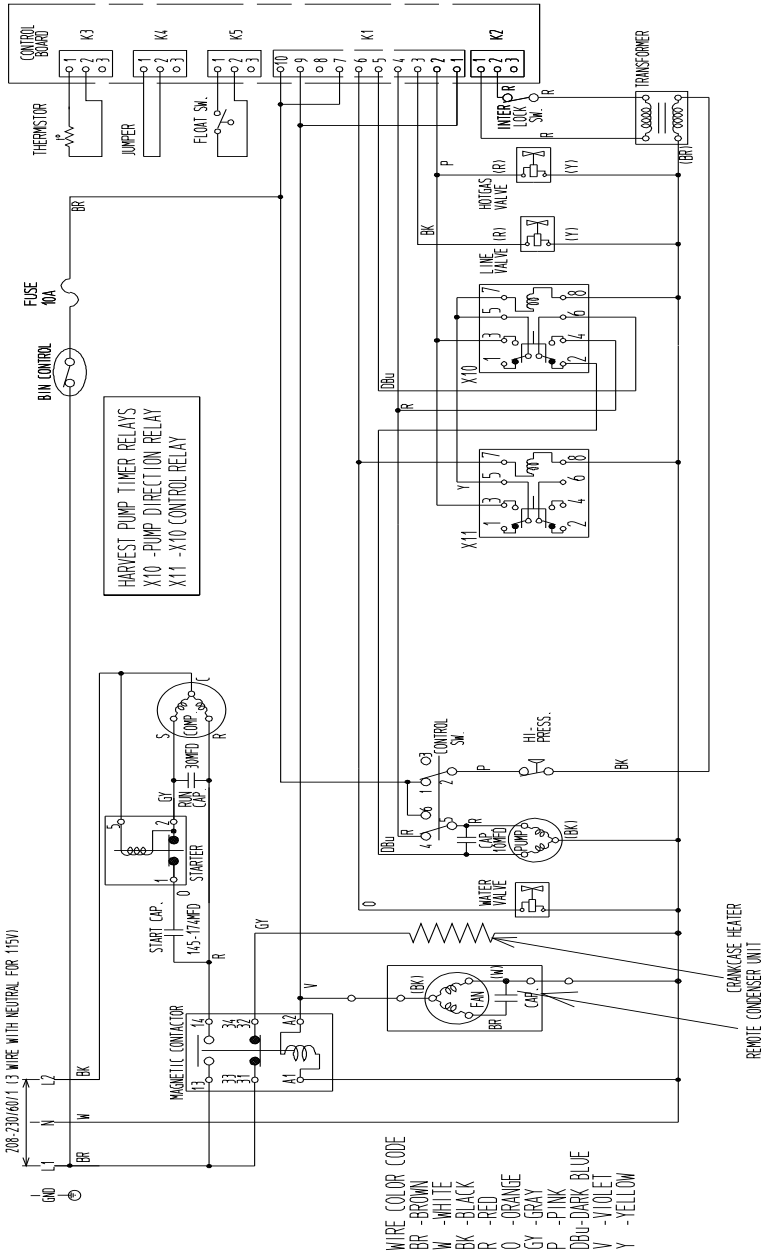



# HH KM-1301SRH3

Serial Code: U0 and before

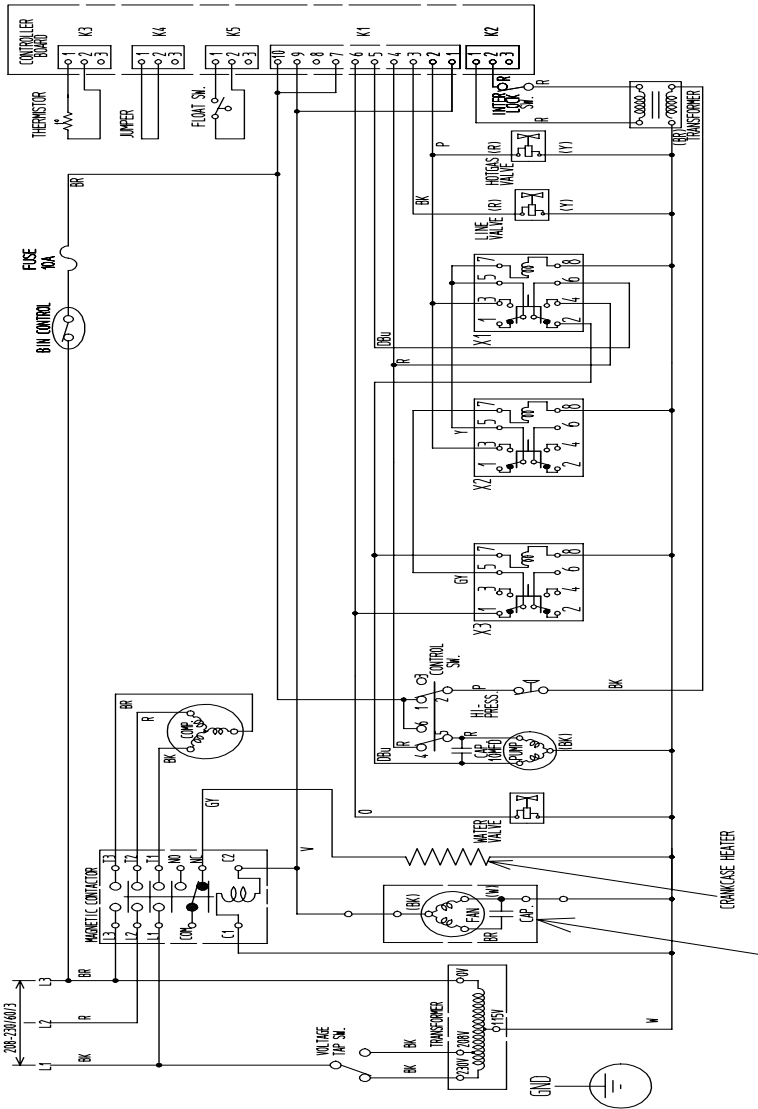

## WIRE COLOR CODE

- BR - BROWN
- W - WHITE
- BK - BLACK
- R - RED
- O - ORANGE
- GY - GRAY
- P - PINK
- DBU - DARK BLUE
- V - VIOLET
- Y - YELLOW

# II KM-1301SRH3

Serial Code: U1 and after

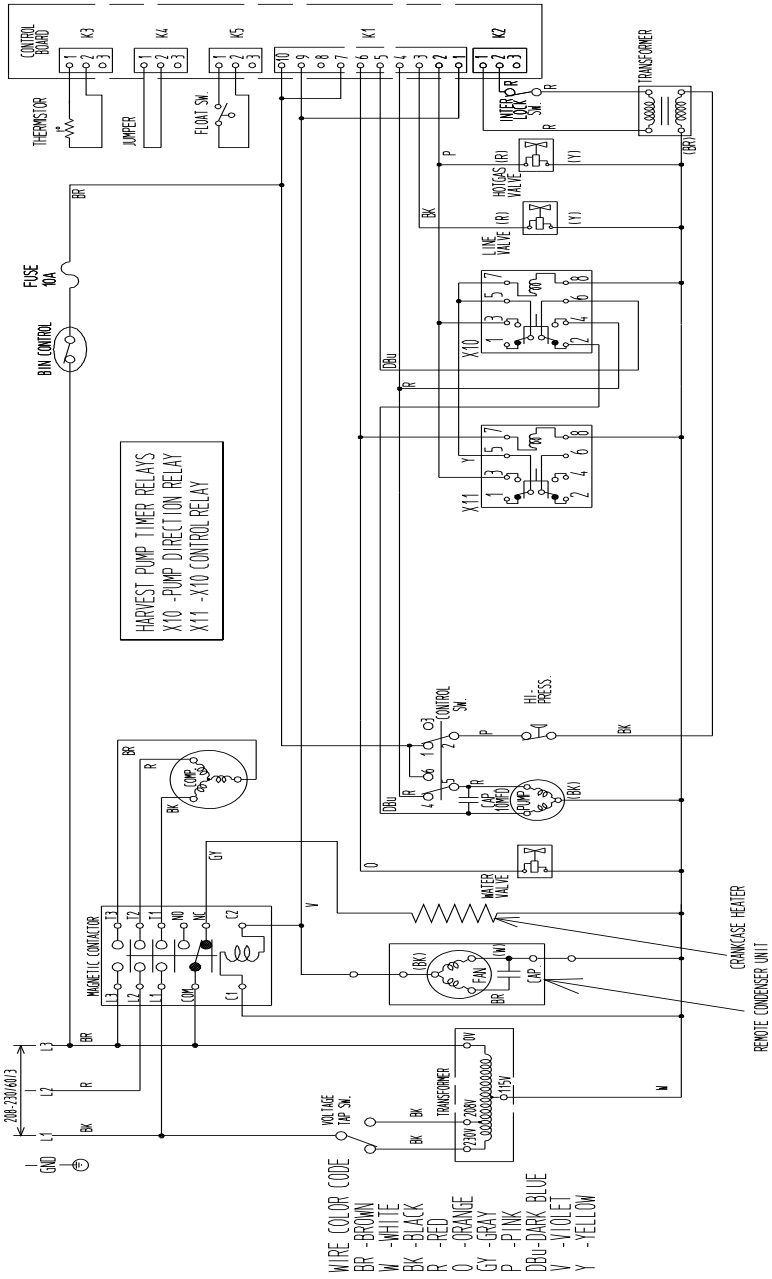

# JJ

## KM-1300SRH, KM-1340MRH, KM-1600SRH, KM-1600MRH, KM-1601SRH, KM-1601MRH

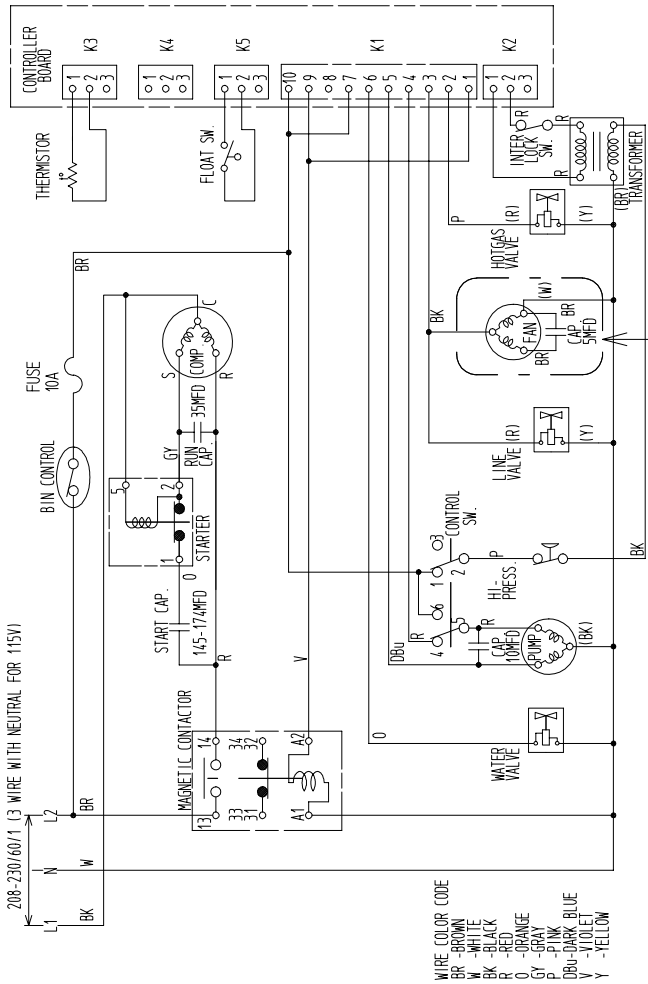

ONLY AIR COOLED MODEL 3A2395-011

# KK

## KMS-1400MLH w/SRK-14H(3)

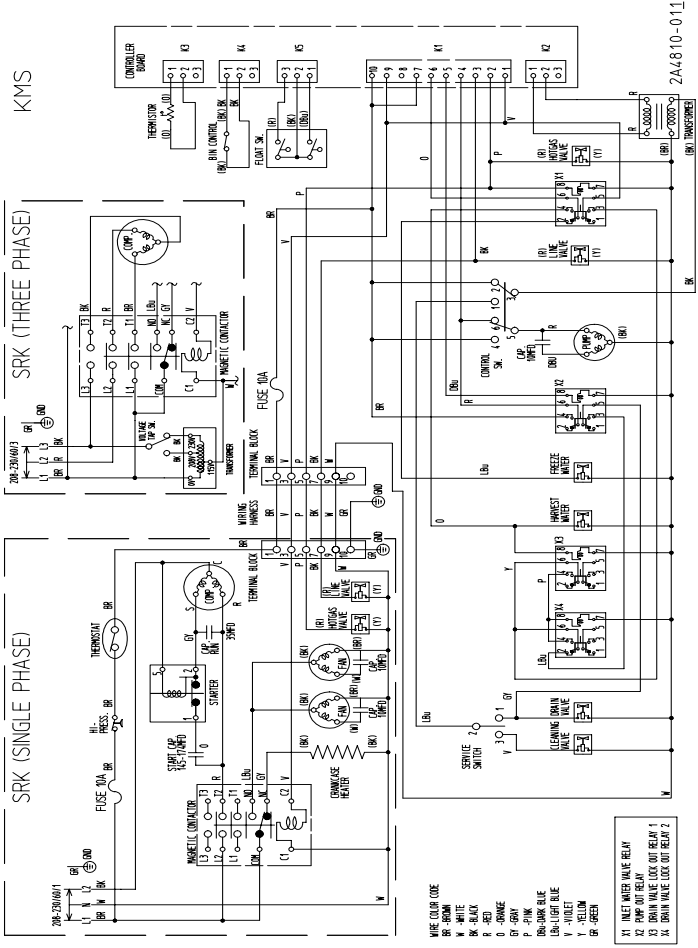

- WIRE COLOR CODE**
- BR-BROWN
  - W-WHITE
  - B-BLACK
  - P-PINK
  - D-DORADO
  - GR-GRAY
  - P-PINK
  - BR-BROWN
  - BL-LIGHT BLUE
  - Y-YELLOW
  - GR-GREEN

- X1 INLET WATER VALVE RELAY
- X2 PUMP OUT RELAY
- X3 DRAIN VALVE LOCK OUT RELAY 1
- X4 DRAIN VALVE LOCK OUT RELAY 2

2A4810-011

# LL

## KM-1600SRH3, KM-1600SWH3, KM-1600MRH3, KM-1601MRH3

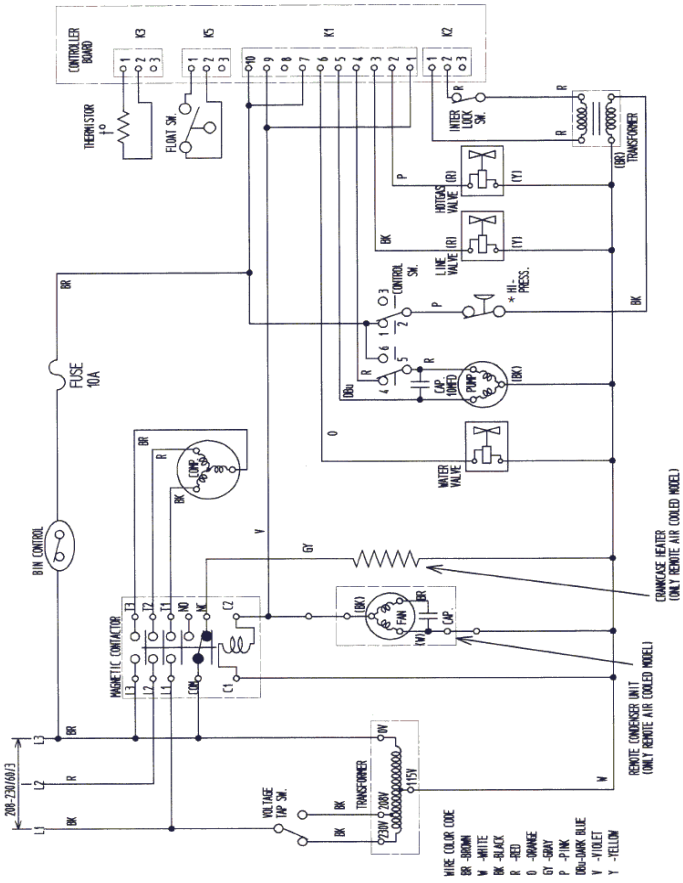

# MM KM-1300MAH KM-1800SAH, KM-1900SAH,

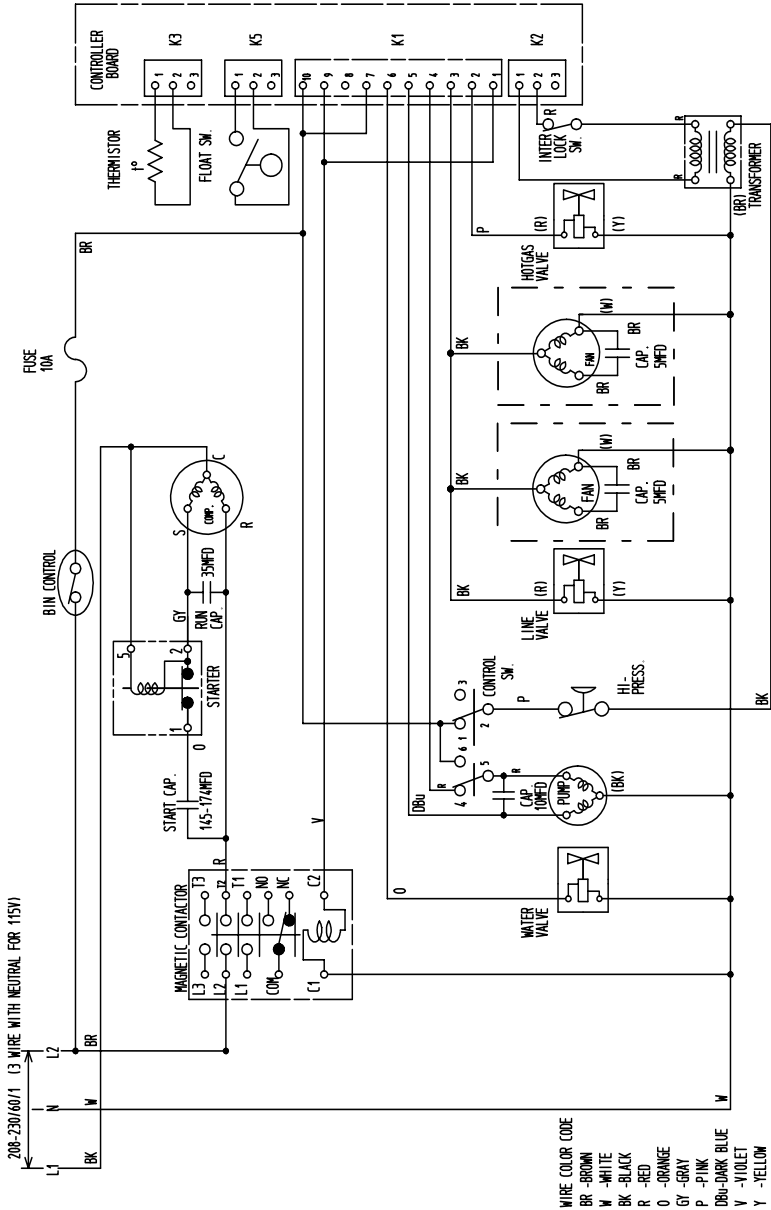

WIRE COLOR CODE  
 BR - BROWN  
 BK - BLACK  
 W - WHITE  
 R - RED  
 O - ORANGE  
 GY - GRAY  
 P - PINK  
 DBU - DARK BLUE  
 V - VIOLET  
 Y - YELLOW

# NN

## KM-1600MRH3/SRH3, KM-1601MRH3/SRH3, KM-1800SWH3/SRH3, KM-1900SWH3/SRH3, KM-2000SWH3/SRH3

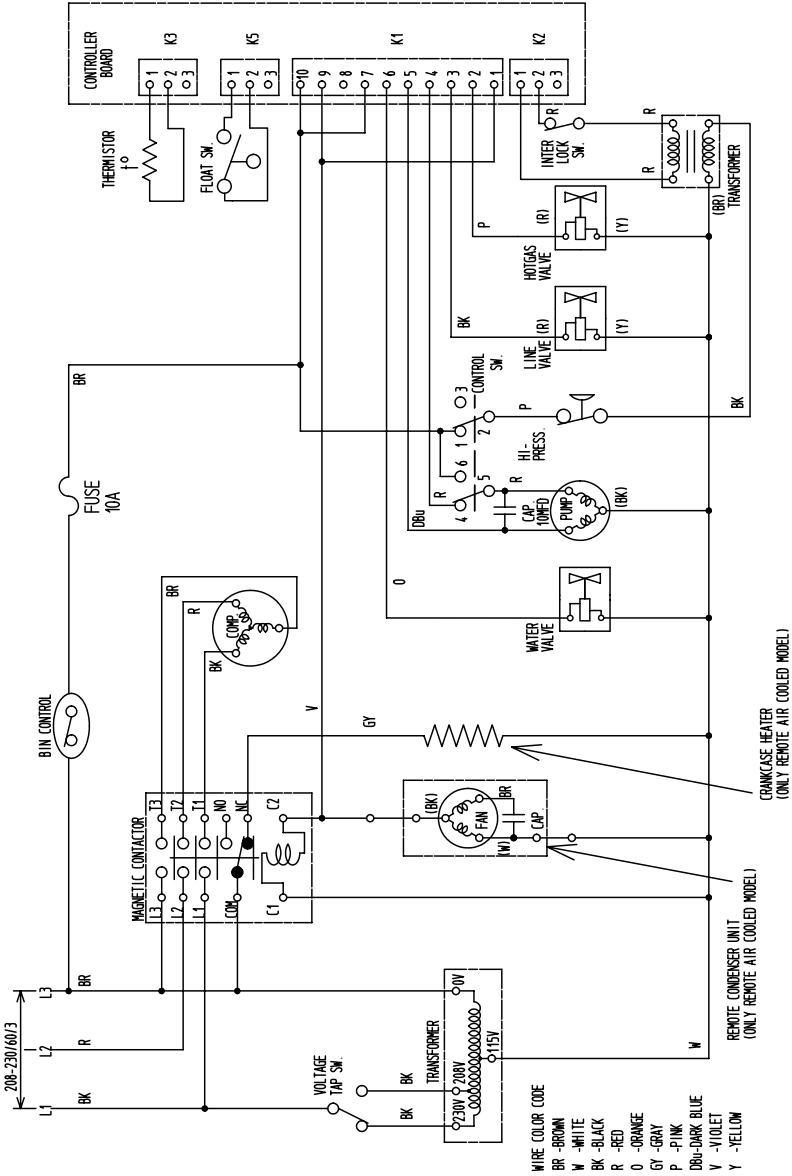

OO

# KM-180SWH, KM-180SRH, KM-190SWH, KM-190SRH

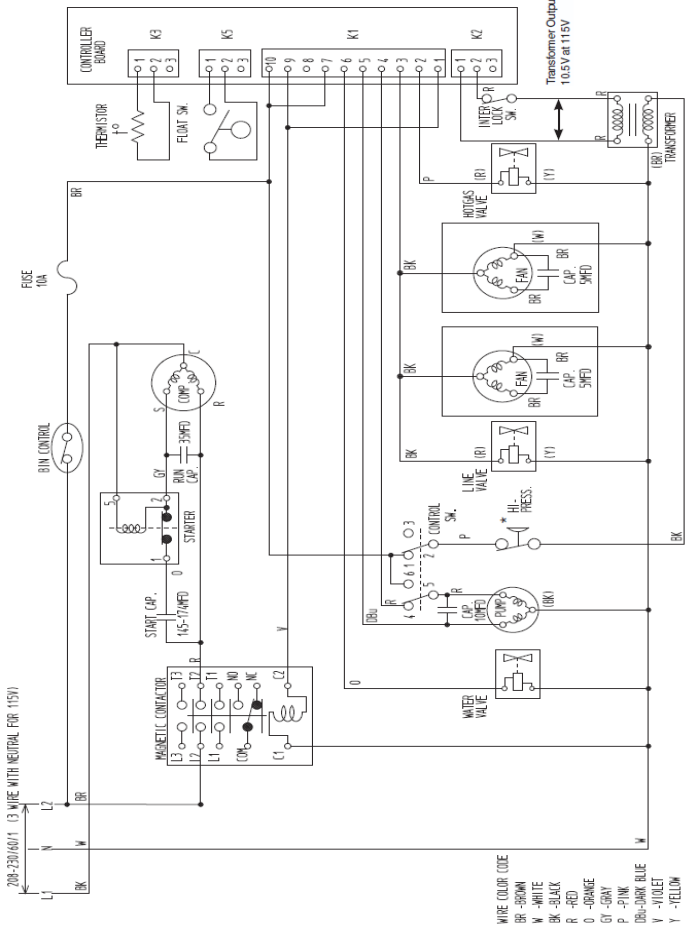



# PP KM-1800SAH3, KM-1900SAH3

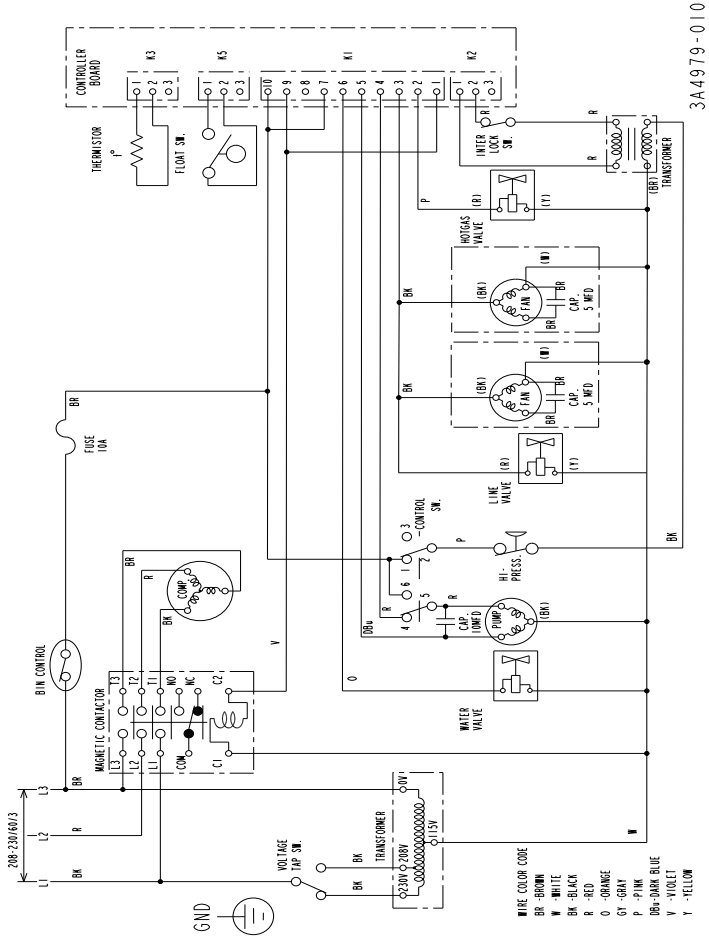

# QQ

## KMS-2000MLH & SRK-20H/3,

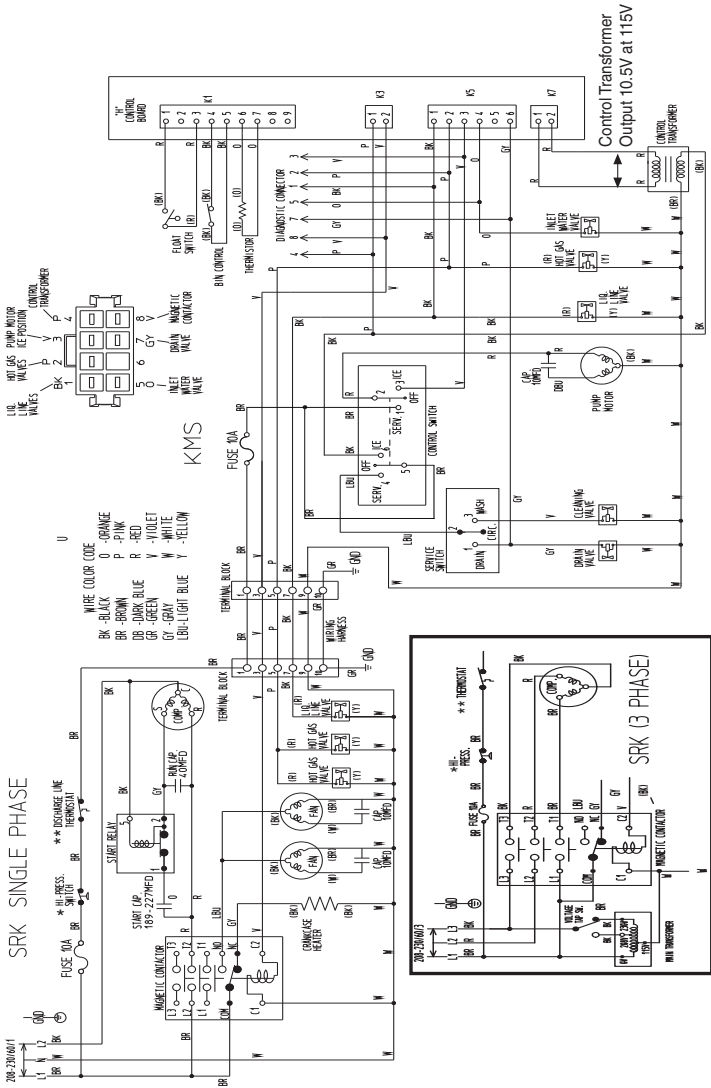

* High-Pressure Switch	
Cut-out	426 $\pm$ 20 PSIG
Cut-in	341 $\pm$ 22 PSIG

** Discharge Line Thermostat Switch	
Cut-out	266°F $\pm$ 9°F (130°C $\pm$ 5°C)
Cut-in	239°F $\pm$ 9°F (115°C $\pm$ 5°C)

# RR KM-200SWH3/SRH3, KM-2100SWH3/SRH3, KM-2400SRH3, KM-2500SRH3

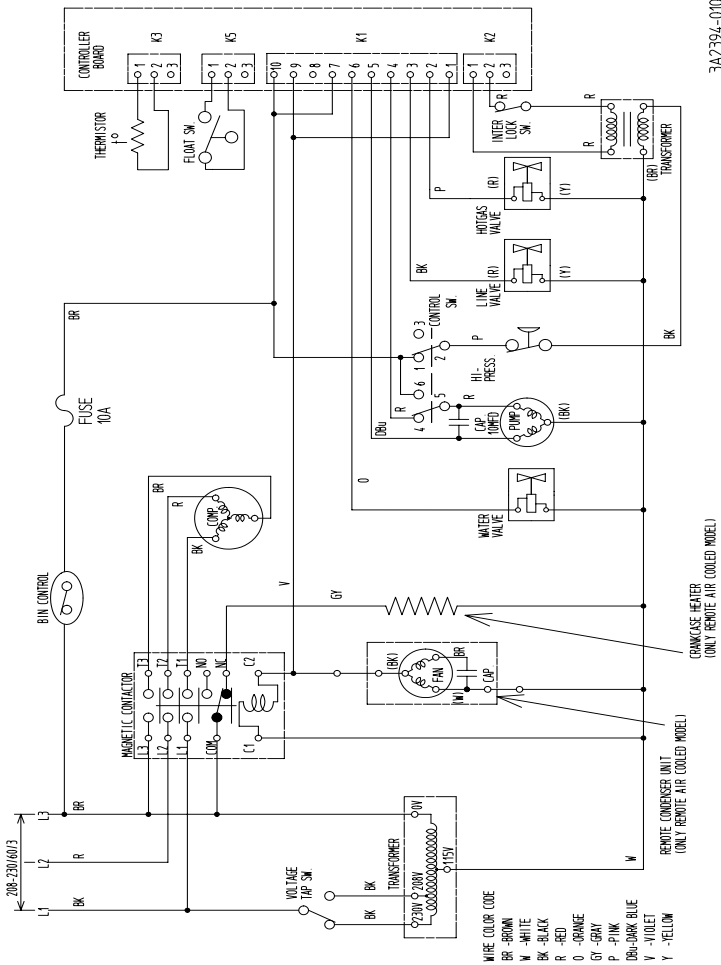

3A2394-010

# SS KMS Wiring Harness Connections

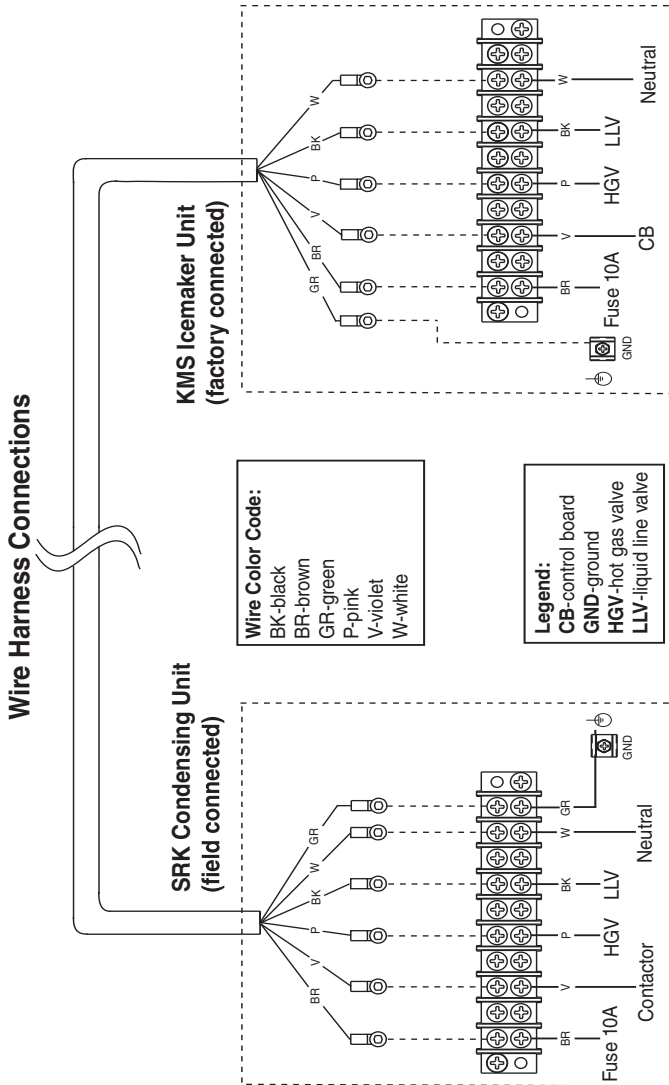

**Note:** A 50 foot long wiring harness is provided and pre-connected to the SRK condensers. It must be properly routed to the MLH unit and connected per the (field connections) on this illustration.



# TECH - SPEC'S

TECHNICIAN'S  
HANDBOOK

**R-134A & R-404A  
H Models**

Flaker, DCM &  
Dispenser Section

Hoshizaki Technical Support  
618 Highway 74 South  
Peachtree City, Georgia 30269

Phone: 770-487-2331

Fax: 770-487-3360

# **TECH - SPEC'S Technician's Handbook #80050B**

This section of the technicians handbook covers all F/DCM Auger style Hoshizaki H-Series ice maker models. Additional technical information, full parts, and service manuals are available for review and download on the Tech Support page of the Hoshizaki web site.

See “[www.hoshizakiamerica.com](http://www.hoshizakiamerica.com)” for manuals, Tech- Tips, and additional technical information on Hoshizaki products.

See Tech-Spec's #80024 purple pocket guide for older models using R-12/502 refrigerant.

See Tech-Spec's #80021 green pocket guide for E-Series models using R-22.

See Tech-Spec's #80045 orange pocket guide for F and early H series ice maker models.

These guides can be downloaded from the Hoshizaki web site or purchased through your local Hoshizaki Distributor. A print out of the guides will be on a 3.5 x 7 format. Set printing preference if larger format is needed.

**FOR FACTORY SUPPORT  
CONTACT HOSHIZAKI TECHNICAL  
SUPPORT AT: 1-800-233-1940**

**E-Mail: [techsupport@hoshizaki.com](mailto:techsupport@hoshizaki.com)**

# Model Nameplate:

<b>HOSHIZAKI ICE MAKER</b>	
MODEL NUMBER	DCM-750BAH
SERIAL NUMBER	
AC SUPPLY VOLTAGE	115-120/60/1
COMPRESSOR	120V 10RLA 70LRA
GEAR MOTOR	120V 3FLA 1/4HP
FAN MOTOR	120V 1.0FLA 50W
AGITATING MOTOR	120V 1.8FLA(TOTAL) 110W
DISPENSING MOTOR	120V 0.9FLA 55W
OTHER	120V 0.6A
MAXIMUM FUSE SIZE	20 AMPS
MAX. HACR BREAKER (USA ONLY)	20 AMPS
MAX. CIRC. BREAKER (CANADA ONLY)	20 AMPS
MINIMUM CIRCUIT AMPACITY	20 AMPS
DESIGN PRESSURE	HI-460PSI LO-290PSI
REFRIGERANT	404A 1 lb. 7.1 oz.

**MOTOR-COMPRESSOR THERMALLY PROTECTED,  
NOT INTENDED FOR OUTDOOR USE!**

**Hoshizaki America, Inc.**  
Peachtree City, GA  
[www.hoshizaki.com](http://www.hoshizaki.com)

 **UL** US LISTED  
ICE MAKER  
946Z

 **NSF.**

 VERIFIED  
Energy Performance  
Energieleistung  
Energieleistung  
VERIFIE

See the Nameplate for electrical and refrigeration specifications. This Nameplate is located on the upper right hand side of rear panel. Since this Nameplate is located on the rear panel of the ice maker, it cannot be read when the back of the ice maker is against a wall or another piece of kitchen equipment. Therefore, the necessary electrical and refrigeration information is also on the rating label, found by removing the front panel of the ice maker. We reserve the right to make changes in specifications and design without prior notice.

## Warranty Information:

### Registration:

Warranty registration is available online and a registration card is supplied with the equipment. Registration must be completed to initiate warranty. The warranty begins on the date of installation if registration procedures are followed. If registration is not completed, the warranty date will be the date of sale or date of shipment from the factory, respectively.

### Warranty Coverage:

The warranty will cover defects in material or workmanship under normal and proper use and maintenance service as specified by Hoshizaki. Coverage for parts and labor is limited to the repair or replacement of parts or assemblies that in Hoshizaki's opinion are defective.

### Coverage Chart:

ITEM	PRODUCT	PARTS	LABOR
Total Unit	AM-50B	2 Years	2 Years
	C-101B	2 Years	2 Years
	Standard Bin from Jan 2012	3 Years	3 Years
	DB/DM	3 Year	3 Year
	F/DCM from Sep 2010	3 Years	3 Years
	All KM Cuber Upright Bin	3 Years 5 Years	3 Years 5 Years
Compressor & Air-Cooled Cond Coil	KM Cuber F/DCM	5 Years	3 Years
		5 Years	3 Years
Evaporator Plate	KM Cuber	5 Years	5 Years
Evaporator, Auger Gear Motor Assy.	F/DCM	3 Years	3 Years
Accessory	Drain Pump	1 Year	---
	Other	90 Days	---

See Warranty Statement supplied with the unit for details. Warranty valid in United States, Canada, Mexico, Puerto Rico, and U. S. Virgin Islands.

Contact factory for warranty in other countries, territories, or possessions.



## F/DCM Installation: General Specs:

The ice machine is not intended for outdoor use.  
Operating Conditions - ALL MODELS

Item	Model	Range
Voltage Range	115V units	104~127V
	208-230V units	187~264V
	220-240 or 230V	198~254V
Ambient Temp.	All	45~100 °F
	Remote Con- denser	-20~122 °F
Water Supply Temp.	All	45~90 °F
Water Supply Pressure	All	10~113 PSIG

Allow 6" clearance at rear, sides, and 20" on top for proper air circulation and ease of maintenance or service.

## Plumbing Requirements: Water Supply:

Model	Line Size	Fitting Size
All F/DCM	3/8" OD	1/2 FPT

\*Water cooled condenser units require two separate supplies sized as per list above.

## Drain Connections:

Model	Line Size	Fitting Size
All Bins	3/4" OD	3/4 FPT
C-100/101BAH	1/2" OD*	1/2 FPT
Flakers/DCM	3/4" OD	3/4 FPT*

\*Some models have 2 drain outlets.

\*Drain lines should never be sized smaller than the factory recommendation. Undersized drain lines can cause water backup and result in water damage.

### **Water Cooled Condenser Outlet:**

Flaker, and DCM models have 3/8" FPT outlet. The condenser drain should be piped separately.

Hoshizaki recommends that the ice machine drain and bin drain be piped separately to the drain connection point allowing 1/4" per foot fall.

Hard pipe (PVC or Copper) is recommended for drain lines. Flex tubing should not be used as the insert fittings tend to restrict the water flow and flex tubing is easily crimped and can cause overflow issues.

### **Vented Tee:**

A 6" vent tee, as shown in the drawing, is recommended on any drain connection to allow for improved water flow. This tee can also allow for ease of cleaning if the drain plugs with scale or bacterial growth. Pour in Chlorine bleach routinely to clear slime and bacterial growth.

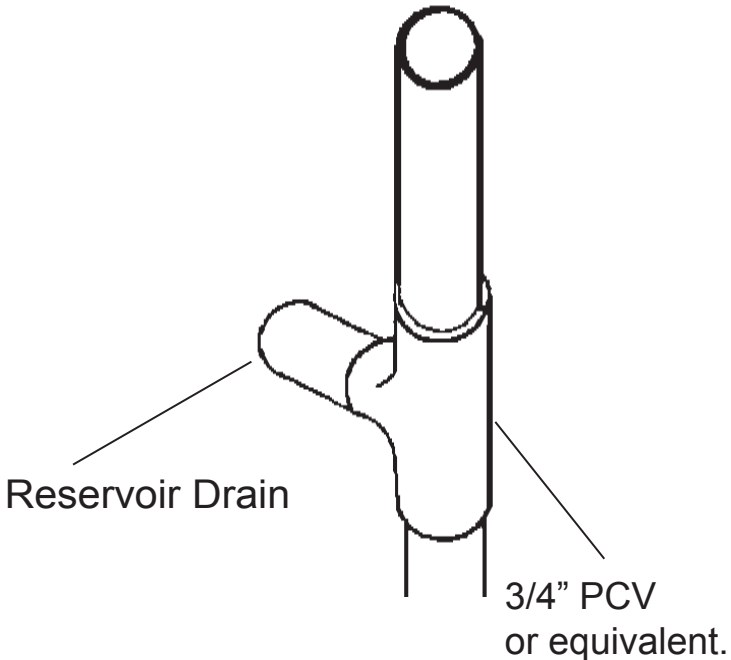

**Note:** Restricting the drain size will cause water to overflow the reservoir or drain pan!

## Flow Rates:

The minimum flow rate requirements for Hoshizaki F/DCM ice maker units are as follows:

Models	GPM
C-100/101BAH	0.66
All F's	0.8
All DCM's (X 2, for ice makeup and water dispensing)	0.8~1

## Filtration:

Hoshizaki recommends that filtration be installed on our products. The type of filtration will vary with local water quality. In some cases, treatment is needed to address water hardness, or high mineral content.

The filtration systems provided by Hoshizaki are considered basic filtration with minimal water treatment capabilities.

There are many possibilities for water treatment: In general, a filter median is used for sediment/dirt and trash. Carbon is used for taste and odor and polyphosphate is used for scale control.

There are also other possibilities, such as a water softener (not recommended for F/DCM's), or in some cases, reverse osmosis (RO). RO can be aggressive, but is acceptable if the RO output has a neutral pH of 7.

Contact your local Hoshizaki distributor, or a water expert, for the best recommendation for your area.

**Note:** Filtration, or treatment, must be sized properly to be effective. Inadequate flow rate will cause problems with production and operation of the ice maker.

## General Installation:

As always, you should follow the installation instructions that are provided in the instruction manual supplied with the unit. Three things are critical for a proper F/DCM installation:

1. The water temperature should fall within the 45° F to 90° F range.  
**Note:** Colder water can cause excess stress on the auger gear motor which may activate the gear motor overload.
2. A filter system is very important in poor water quality areas as high mineral content can cause premature bearing wear, poor production, and inefficient operation.
3. The unit should be level, front to back, side to side to assure proper evaporator water level and maximum production. This is necessary because of the gravity feed water distribution.

## Cubelet Models:

The DCM product produces cubelet ice. Most flaker models are also available to produce cubelet ice. This requires a different extruding head and cutter at the top of the evaporator assembly and in most cases, the addition of an evaporator barrel heater. The flaker models which are produced as cubelet models are designated by a -C at the end of the model number. Example: F-1001MAH-C

It is important to note that converting a flaker to a cubelet maker reduces the overall production by around 8~10%. This drop in production is due to the compacting of the ice in the extruding head. The flaker gear motor is sized to handle the extra load of producing cubelet ice with only a slight increase in the running amperage. The evaporator outlet temperature and operating pressures will be similar to the standard flaker model. Use the temperature and pressure information provided on the standard flaker performance data provided as a bench mark when diagnosing a converted cubelet (-C) unit.

## Installing Cubelet Models on Dispensers:

The cubelet models produce a hard chunklet of ice. This ice will dispense well as long as the dispenser is set up for dispensing cubelet/chunklet (sometimes called nugget) style ice. A standard dispenser will crush the cubelets and pack

the ice in the bin rather than dispensing. In this case, there is nothing wrong with the ice maker.

Before installing a cubelet model on a dispenser, call the dispenser manufacturer with the model and serial number and verify that the dispenser will dispense cubelet ice. Some manufacturers can supply a kit to modify the dispenser while others make a special model or do not offer cubelet dispensing.

### Remote Applications:

When installing a remote application, the unit/condenser combination must match with the chart for proper unit operation and efficiency. Check service & parts manuals on web for proper model match and parts information.

### Remote Condenser Chart

Condenser Model	Remote Model Number's
URC-5F	*F-1001M, FD-1001M
URC-14F	F-1500/1501M
URC-22F	F-2000/2001M
SRC-10H	FS-1001/1022MLH
SRC-14H	FS-1500MLH
*Model has 2 possible matches.	
<b>Out of production:</b> URC-6F, URC-7F, URC-12F, URC-20F, URC-21F, URC-24F	

Functional service parts are available for out of production models.

### Use of Non-OEM Condensers:

A properly sized non-OEM multi-pass condenser can be used on Hoshizaki standard remote units with prior written factory approval. See service bulletin SB99-00019R1 and follow the instructions for proper approval.

Mis-matching condensers and installing remotes on a non-approved remote will affect the unit operation and warranty coverage. If you have a non-OEM condenser application, verify approval and application through Technical Support prior to committing to repair or warranty coverage.

## Remote Lines:

Hoshizaki has 3 precharged line set lengths available: 20 ft, 35 ft, and 55 ft. Line sets are available in different sizes for different models.

**Line Set Identification Code** ex. R404 - 35610

R404 - Refrigerant

35 - Length In Feet

6 - Liquid Line Size in 16th's

10 - Discharge Line Size in 16th's

## Flaker Model Line Set Applications

Models	Line Set	LL-DL (Size)
F-1001MRH/J, FD-650/1001MRH/J	R404-2046-2 R404-3546-2 R404-5546	1/4" OD - 3/8" OD
FS-1022/1001MLH	R404A-20410 R404A-35410 R404A-55410	1/4" OD - 5/8" OD
F-1500/1501MRH	R404A-2068-2 R404A-3568-2 R404A-5568-2	3/8" OD - 1/2" OD
FS-1500MLH, F-2000/2001MRH	R404A-20610 R404A-35610 R404A-55610	3/8" OD - 5/8" OD
If hard piping or fabricating a line set, insulate both lines separately and use Quick Connect Kit HS-2150 except on solder connection models. Line sets contain a minimal refrigerant vapor charge of 15 to 30 psig to break the vacuum.		

The fittings used on precharged line sets are one shot couplings. They do not re-seal when disconnected. Always evacuate the system before disconnecting the fittings and replace them with new sealed fittings.

Leaving excess line set coiled on the rooftop or in the ceiling is not recommended. It can cause oil traps or be easily crimped and restricted and reflects a poor installation. For installations with excessive line set length, Hoshizaki recommends that you follow these steps to cut out the excess line set before making the connections.

1. Evacuate and recover the line set charge,
2. Cut out the excess,
3. Resolder the lines,
4. Leak check and charge with 15 to 30 PSI vapor charge using the correct refrigerant.
5. Make the connections to the condenser and head.

## Flakers/DCM'S Charge Chart (Refrigerant R-404A)

\*Always verify total charge with nameplate amount. If listed charge is different, use nameplate amount.

<b>Model</b>	<b>Total Charge</b>	<b>Refrigerant</b>
DCM-270BAH	14.8 oz	R404A
DCM-300BAH	15.9 oz	R404A
DCM-500BAH	1 lb 4.1 oz	R404A
DCM-500BWH	14.1 oz	R404A
DCM-750BAH	1 lb 7.1 oz	R404A
DCM-750BWH	1 lb 2.7 oz	R404A
DCM-751BAH	1 lb 10 oz	R404A
DCM-751BWH	1 lb 6 oz	R404A
DKM-500BAH	2 lbs	R404A
DKM-500BWH	1 lb 2 oz	R404A
DT-400BAH-OS	1 lb 1 oz	R404A
<b>**C-101BAF/H</b>	<b>3.17 oz</b>	<b>R134A</b>
F-330BAH(-C)	7.1 oz.	R404A
F-300BAF(-C)	9.5 oz	R404A
F-450MAH(-C)	1 lb	R404A
F-450MAH(-C)	1 lb	R404A
F-800MAH(-C)	1 lb 10 oz	R404A
F-800MWH(-C)	13.8 oz	R404A
F-801MAH(-C)	1 lb 12 oz	R404A
F-801MWH(-C)	1 lb 1 oz	R404A
F-1001MAH(-C)	1 lb 12 oz	R404A
F-1001MAH-22C	1 lb 7 oz	R404A
F-1001MLH(-C)	3.5 oz	R404A
F-1001MRH(-C)	4 lbs 1 oz	R404A

<b>Model</b>	<b>Total Charge</b>	<b>Refrigerant</b>
F-1001MWH(-C)	15 oz	R404A
F-1001MAJ(-C)	2 lbs 4.1 oz	R404A
F-1001MWJ(-C)	12.3 oz	R404A
F-1001MRJ(-C)	4 lbs 1.2 oz	R404A
F-1500MAH(-C)	2 lbs 5 oz	R404A
F-1500MWH(-C)	1 lb 4 oz	R404A
F-1500MRH(-C)	9 lbs 9 oz	R404A
F-1501MAH(-C)	2 lbs 5 oz	R404A
F-1501MWH(-C)	1 lb 4 oz	R404A
F-1501MRH(-C)	9 lbs 9 oz	R404A
F-2000MLH(-C)	3.5 oz	R404A
F-2000MWH(-C)	2 lbs	R404A
F-2000MRH(3)(C)	14 lbs 9 oz	R404A
F-2001MLH(-C)	3.5 oz	(-C)
F-2001MWH(-C)	2 lbs	R404A
F-2001MRH(3)(-C)	14 lbs 9 oz	R404A
FD-650MAH(-C)	12.4 oz	R404A
FD-650MWH(-C)	15 oz	R404A
FD-650MRH(-C)	2 lb 1.2 oz	R404A
FD-1001MAH-C	1 lb12 oz	R404A
FD-1001MAJ-C	4 LB	R404A
FD-1001MRJ-C	8 lb 6 oz	R404A
FS-1001MLH-C w/ SRC-10H	8 lbs 6 oz	R404A
FS-1022MLH-C w/ SRC-10H	8 lbs 6 oz	R404A
FS-1500MLH w/ SRC-14H	11 lbs	R404A

### **Heat Load for AC & Cooling Tower**

The heat of rejection information provided by model number in the following chart should be used for sizing air conditioning equipment or water-cooled cooling tower applications.



<b>Flaker &amp; DCM Heat Load Chart BTU/hr.</b>		
<b>Model</b>	<b>Air Cooled</b>	<b>Water Cooled</b>
DCM-270B	3,532	----
DCM-300BAH	3,500	----
DCM-500B	6,300	5,438
DCM-750B	8,314	7,945
DCM-751B	9,300	8,500
DKM-450	8,098	6,900
DT-400B	4,923	----
C-100BAE-AD	1850	----
F-300B	3,178	----
F-330BAH(-C)	3,800	----
F-450MAH(-C)	5,150	----
F-800M_H(-C)	7,500	6,270
F-801M_H(-C)	6,398	5,155
F-1001M_H/J(-C)	9,100	7,110
F-1500/1501M_H(-C)	15,323	10,100
F-2000M_H/J(_C)	----	15,530
FD-650M-H(-C)	6,800	4,500
FD-1001MAH-C	8,800	----
FD-1001M_J	9,100	7,110
All MLH models	1,400	----
<b>FS Condenser Heat Load Chart - BTU/hr.</b>		
SRC-10H	10,500	
SRC-14H	17,700	

\*Figures shown are at 90° F air temp. 70° F water temp. conditions.

\*For water cooled applications, always allow for a pressure differential of 10 psi across the water cooled condenser. This means that the inlet pressure must be at least 10 psi higher than the outlet pressure to allow for proper water flow through the water regulating valve and condenser.

# Component Technical Data

## COMPRESSOR DATA

Remote units use -02 compressor which has crankcase heater.		LRA = Lock Rotor Amperage		RWR = Run Winding Resistance			
* Models use R134A, all others use R404A, -E = European model / 50 hz.		SWR = Start Winding Resistance		RLA = Running Load Amperage (see performance data)			
Resistance is measured with wheatstone bridge under controlled ambient conditions.							
Model	Part #	Manufacturer #	LRA	SWR (Ohms)	RWR (Ohms)	Oil Type	Oil Charge (Fl.oz./cc)
DCM-270BAH, DCM-300BAH	4A2272-01	Copeland	39	7.3	1.2	POE EAL	15/444
DCM-500B_H (-OS), DT-400BAH-OS/AR	*4A2300-01	Copeland	51	4.08	0.59	POE EAL	24/710
DCM-750B(-OS), DKM-500BAH	*4A1843-01	Copeland	60	4.2	0.66	POE EAL	24/710
DCM-751B_H	4A5158-01	Copeland	77	2.391	0.36	POE EAL	15/440
DKM-500BWH	4A4376-01	Copeland	70	2.6	0.4	POE EAL	15/444
* C-100BAF, C-101BAH	455942-01	Panasonic	14.5	9.69	2.41	FREOL	8.5/250
F-300BAF	4A4614-01	Copeland	39	7.3	1.2	POE EAL	15/444

## COMPRESSOR DATA

Remote units use -02 compressor which has crankcase heater.		LRA = Lock Rotor Amperage		RWR = Run Winding Resistance			
* Models use R134A, all others use R404A, -E = European model / 50 hz.		SWR = Start Winding Resistance		RLA = Running Load Amperage (see performance data)			
Resistance is measured with wheatstone bridge under controlled ambient conditions.							
Model	Part #	Manufacturer #	LRA	SWR (Ohms)	RWR (Ohms)	Oil Type	Oil Charge (fl. oz./cc)
F-330BAH(-C)	4A4185-01	Danfoss	28	5.4	1.7	POE EAL	10.8/320
F-500BAF(-C), F-450MAH(-C), F-801MA/WH(-C)	*4A2300-01	Copeland	51	4.08	0.59	POE EAL	24/710
F-800M(-C)	*4A1843-01	Copeland	60	4.2	0.66	POE EAL	24/710
F-1001M(-C), F-1001M_J(-2), FD-1001MAH-C, FD-1001M_J-C	3A6900-01	Copeland	34	4.89	1.96	POE EAL	24/710
F-1500M(-C)	4A1539-01	Copeland	56	3.044	1.107	POE EAL	45/1279
F-1501M_H(-C)	4A1539-03	Copeland	56	3.044	1.107	POE EAL	45/1279
F-2000M	4A1420-02	Copeland	96	2.333	0.623	POE EAL	45/1279
F-2000MRH3(-C)	4A1419-02	Copeland	75	Line to Line 1.058		POE EAL	45/1279

## COMPRESSOR DATA

* Remote units use -02 compressor which has crankcase heater.		LRA = Lock Rotor Amperage		RWR = Run Winding Resistance				
* Models use R134A, all others use R404A, -E or 50 = European model / 50 hz.		SWR = Start Winding Resistance		RLA = Running Load Amperage (see performance data)				
Resistance is measured with wheatstone bridge under controlled ambient conditions.								
F-2001M_H(-C)	4A4890-01	Copeland	CS20-K6E-PFV	96	2.333	0.623	POE EAL	45/1279
SRC-10H	4A3494-01	Copeland	RS80C2E-CAV-219	46	4.45	1.36	POE EAL	24/710
SRC-14H	4A4134-03	Copeland	CS12K6E-PFV	56	3.044	1.107	POE EAL	45/1279

## SUBSTITUTE COMPRESSOR DATA

IF ORIGINAL COMPRESSOR SUBS, USE INFORMATION BELOW FOR SUBSTITUTE PART NUMBER OR LOCATE PART NUMBER ON PREVIOUS CHARTS.

Original Compressor part number	Part #	Manufacturer #	LRA	SWR (Ohms)	RWR (Ohms)	Oil Type	Oil Charge (Fl.oz./cc)
Subs for 4A2300-01	4A1726-40	Copeland	RS43C1E-CAA	54.5	2.66	POE EAL	15/440
Subs for 4A1843-01	4A5158-01	Copeland	RST61C1E-CFA	77	2.391	POE EAL	15/440

## Water-Cooled Head Pressure Controls:

An adjustable (Pressure Modulated) water-regulating valve is installed on the water-cooled condenser **outlet**. This is unique to Hoshizaki water-cooled products and maintains cleaner operation and instant condenser cooling at start-up. A #V46, Johnson Controls Penn valve, is used. The Penn valve is identified by a label on the valve housing.

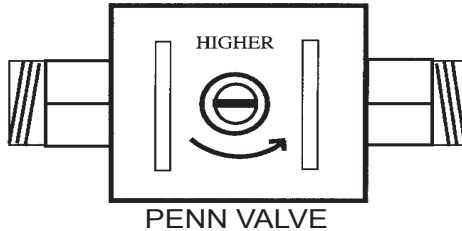

ADJUSTMENT CONTROLS	
CW	lower pressure and outlet water temperature with higher water flow
CCW	higher pressure and outlet water pressure with lower water flow

CONDENSER OUTLET WATER TEMPERATURE RANGE		
Model	Range	High side pressure
All KM	104 ~ 115 °F	270 psig.
All DCM	100 ~ 104 °F	260 psig.
All F	100 ~ 104 °F	260 psig.

If the water-cooled unit has been in operation for a long period of time, adjusting the water-regulating valve may not allow proper pressures.

In this case: the water-cooled condenser likely contains an exorbitant amount of scale and requires cleaning.

An acid based condenser cleaner should be circulated using an acid pump, in reverse flow through the coil until the inner tube is free of scale. Once the scale is removed, the water-regulating valve should be adjusted to maintain the range and pressure listed above.

## High Pressure Safety Switch:

An automatic reset high pressure safety switch is utilized on all Hoshizaki ice makers. The typical high pressure switch is an automatic reset switch. Both capillary and stub style switches are used depending on the model and serial.

**The part numbers & settings are as follows:**

<b>R404A Pressure Switch Chart</b>			
<b>Capillary type Models</b>	<b>part #</b>	<b>cut out (psig.)</b>	<b>cut in (psig.)</b>
DCM-270BAH>T-2, DCM-500/750BWH>V-2, SRC-10H >A-0(C), F-300BAF >A-1(K), F-500BAF, F-450M>V-0, F-800M_H, F-801MAH >V-1, F-801MWH >U-0(H), F-1001M_H >C-1, F-1500MAH >A-0, F-1500MWH/MRH >V-0, F-2000MWH/MRH >V-1	433441-05	384 ± 21.3	284 ± 21.3
DCM-500BAH >V-1, DCM-750BAH >V-0	433441-07	412 ± 21.3	327 ± 21.3
<b>Stub Type</b>			
F-330BAH	463180-01	426 ± 21.3	341 ± 21.3
DCM-300BAH, DCM-500BAH V-2>, DCM-750BAH V-1>, DCM-751BAH, F-1001MAH/MRH >C2, F-2001MRH, SRC-10H A-0(D)>	463180-04	412 ± 21.3	327± 21.3
DCM-500/750BWH>V-1, DCM-751BWH, F-300BAF A-1(L)>, F-450M V-1>, F-1001MWH > C-2, F1500MAH A-1>, F-1500MWH/MRH V-1> F-1501M, F-2001MWH, F-2000M_H V-2>, SRC-14H	463180-05	384 ± 21.3	284± 21.3

## Bin Controls:

Flaker models will use one of 3 types of bin controls. The type of bin control will vary depending on the unit style or model and serial number.

### 1. Thermostatic Bin Control:

The thermostatic bin control (TBC) is optional for use with Cubelet dispenser applications. (Optional TBC Kit for dispenser applications available through sales). It is a secondary control that operates the control board. The board switches 115 volts to the components as the sequence dictates.

A thermostatic capillary bulb is mounted in the ice drop zone area or on a drop down bracket which extends into the bin cavity. The thermostatic control opens on temperature drop and closes on temperature rise. When ice touches the thermostatic bulb, the bulb pressure opens the bin control contacts to shut the unit down. The unit will not operate in the ICE position, **unless** the thermostatic bin control switch is closed.

The thermostatic bin control will shut the unit down at any point if ice contacts the control bulb. Shut down time depends on the control adjustment. This adjustment is factory set, however it should **always** be checked at start-up or replacement to assure proper operation. The factory setting is to shut off within 3~10 seconds after ice contacts the bulb.

**NOTE: TBC in high altitude areas requires adjustment.**

### 2. Mechanical Bin Control:

Flaker / DCM units use a mechanical bin control. On some Flaker models, this control is a secondary or backup. A paddle pivots on a hinge pin to operate either a micro-switch or magnetic proximity switch. The DCM-270B model uses either magnetic switch or a lift pin and micro switch. Ice pushes against the paddle to move it away or to lift the switch mechanism.

For proper operation, make sure that the paddle swings freely. Check this control for an open circuit when the paddle is held away from the magnetic proximity switch or lifts the micro switch. The best location to check this control is at the control board connections. Simply disconnect the terminals to the switch at the board and check it with an ohm meter.

### 3. Infrared Controls:

The FS/FD models use an infrared eye control sensor, mounted to the base of the ice chute. When the eye senses ice, it starts a time delay relay. When the timer completes, the unit will shut down.

This control is used in conjunction with a mechanical proximity switch mounted in the top of the spout. The mechanical control acts as a safety backup for the primary infrared control.

The spout mounted mechanical control is referenced as bin control #1. The infrared sensor control is referenced as bin control #2.

Since it is designed for dispenser applications, the control adjust to vary the ice level in the bin. The infrared eye control operates on the control transformer power. The adjustment is made to a delay timer that delays shut down and allows the unit to fill more or less in the bin. Adjusting for a longer delay fills the dispenser to a higher level.

Bin control #2 is the primary control for unit operation. Bin control #1 is the back up spout safety. If this control is cycling the unit, check the operation of bin control #2.

An audible alarm will occur if #2 control fails on these models. See service bulletin SB09-0004 for operation and diagnosis of this infrared control.

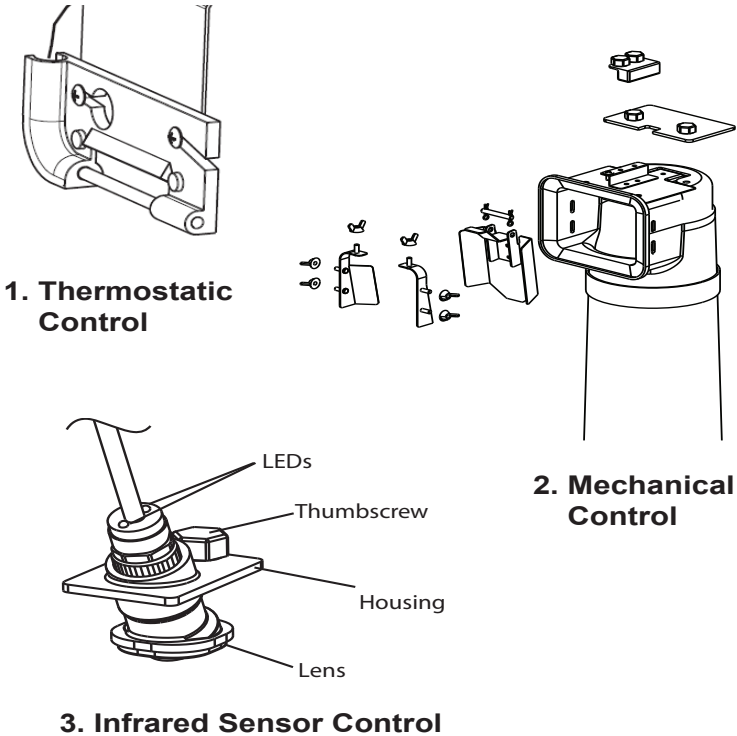



## Flaker Control Boards:

The original flaker control board below is HA part # 437305-01 and was used on all flakers and the DCM-240/270B units for many years. It was a simple sequence timer with no adjustments. This board is no longer produced and now subs to the Lancer board HA Part # 4A5591-01.

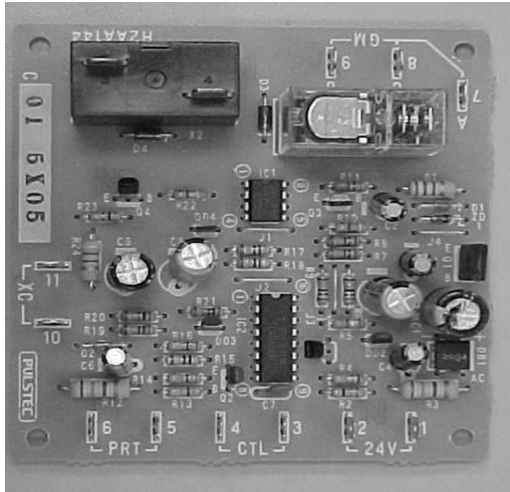

**HA # 437305-01 & 02**

HA Part # 4A5591-01 is similar in size and is a direct replacement with a simple adjustment of the dip switches. This board has LED status indicators. The Power OK LED will blink when 24V control voltage is supplied. The GM and CM LED's will light when the component is energized.

The dip switch adjustments are as follows:

Dip Switches	1	2	3	4
DCM-240/270BAH	OFF	OFF	OFF	OFF
All Flakers	ON	OFF	OFF	OFF

The only 115 Volt connections on the board are the black compressor relay terminals. The other terminals are 24V control voltage connections. This sub board is a direct replacement once the dips switches are set for the application. The dip switches are used to set the control shut down time...Flakers shut down in 6.7 seconds and the DCM shuts down in 0.6 seconds after the bin control opens.

## Lancer Board

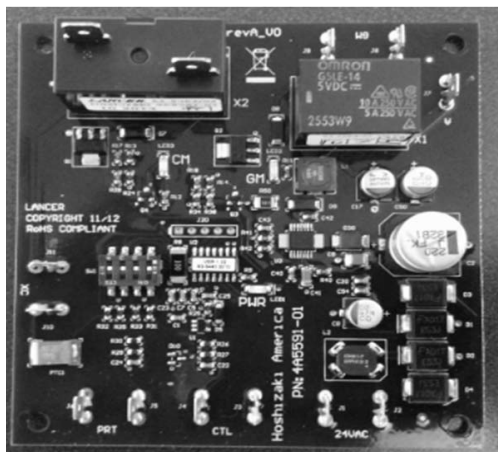

HA # 4A5591-01

### F-A Control Board:

The F-A control board was developed as a universal board with additional safeties, longer delay timers, audible alarms and dip switch adjustments for flexibility between models.

It also incorporates a power supply and connections for the infrared sensor bin control. The design incorporates the necessary circuitry for use on other DCM models at a later date. For now, it is utilized on all FD, FS, select DCM's and future F models. This board will not replace 437305-01 or 4A5591-01.

F-A part number 2A4296-01 includes the following alarms. The alarm will repeat every 5 seconds until reset.

**\*\*To reset the manual alarms, turn the power OFF and Back ON.**

1. **1 Beep - Low Water Safety** – This alarm will occur if water supply is interrupted. It will automatically reset when water supply is restored.
2. **2 Beep - Control Switch in DRAIN position** – This alarm will occur if control switch is left in the DRAIN position for more than 15 minutes. It will automatically reset when control switch is moved to ICE.
3. **3 or 4 Beep - High Pressure Alarm**
  - a. A 3 beep alarm will occur if HP switch activates (opens) first or second time in 1 hour. Unit will shut down and alarm will automatically reset

when HP switch closes.

- b. A 4 beep alarm will occur if HP switch activates third time in 1 hour. The machine will shut down and must be manually reset. The high pressure issue must be resolved in this case.

4. **5 Beep – Freeze Timer Alarm** – This alarm will occur if lower float switch does not open to refill reservoir within 30 minutes of the upper float switch closing. The machine will shut down and must be manually reset. System diagnosis is required in this case.

5. **6 Beep – Low Voltage Alarm** – If supply control voltage drops to 92 volts +/- 5% unit will shut down to protect the components and Power OK LED will turn off. Alarm will automatically reset when voltage corrects.

6. **7 Beep – High Voltage Alarm** – If control voltage reaches 142 volts +/- 5% unit will shut down to protect the components and Power OK LED will turn off. Alarm will automatically reset when voltage corrects.

7. **8 Beeps – Gear Motor Alarm** – Occurs if gear motor-protect relay circuit operates, compressor and gear motor will stop. Manually reset after checking gear motor circuit.

8. **9 Beeps – Bin Control Alarm** – Occurs if unit shuts down on bin spout control and infrared sensor is calling for ice. Manually reset and check infrared bin control operation.

Adjustable dip switches are provided on this control board. These dip switches will allow flexibility in the board application. This control board will be used for other models at a later date. They function as follows:

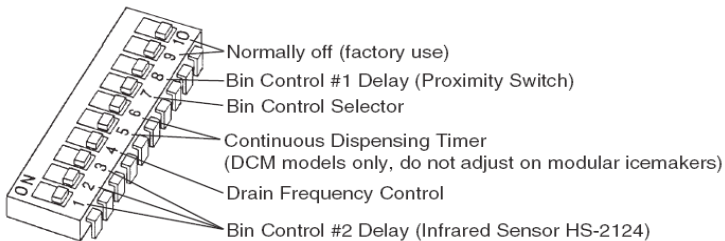

## F-A Board Layout:

This pictorial will allow you to locate the board component locations and become more familiar with the board. You will see this board used on future F/DCM products.

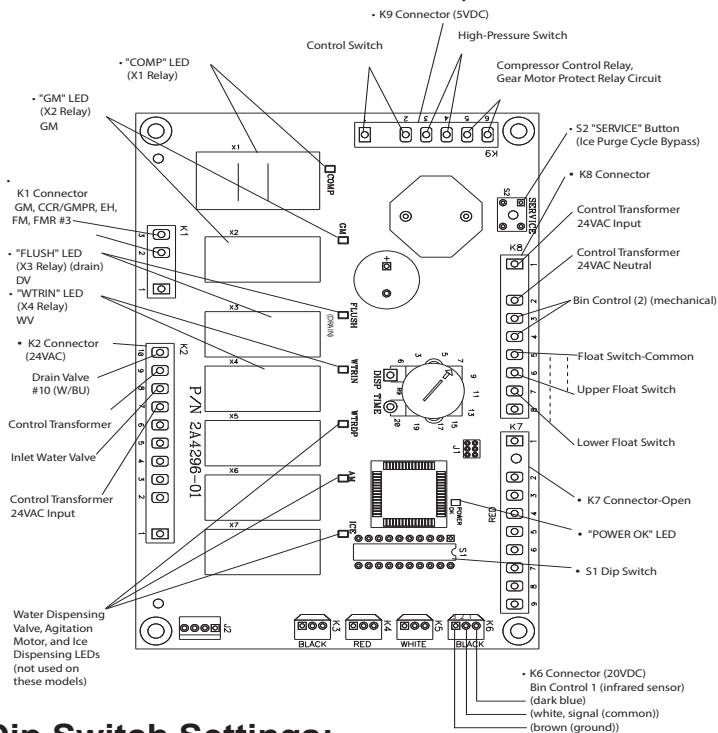

## Dip Switch Settings:

**F-A Board Dip Switch Setting Chart**

Factory Dip Switch Settings:	SWITCH CODE 1=ON 0=OFF									
	1	2	3	4	5	6	7	8	9	10
Model / Serial code										
F-1001M_H D-0>, F-1001M_J	0	0	0	0	0	0	0	0	0	0
FD-650/1001M, FS-1001/1022/1500M, F-1501/2001M	1	0	0	0	0	0	1	1	0	1
DCM-751B_H	0	0	0	0	1	1	0	1	0	0
DCM-751B_H-OS	0	0	0	0	0	1	0	1	0	0

NOTE: Dip switch settings should remain on the factory setting for proper operation with exception to switches 1, 2 & 3 which adjust the bin control shut down/ice level.

## F-A Control Board Label:

The "POWER OK" LED indicates proper control voltage and will remain on unless a control voltage problem occurs. Board part # 2A2649-01

Sequence Step	LED	Energized Components	Min.	Max.
Fill Cycle	WTRIN	WV	-	-
Ice Purge Cycle	GM	GM, FM/FMR	5 min.	5 min.
Freeze Cycle (with refill)	GM, WTRIN* (refill), COMP	GM, Comp, FM/FMR, LLV, SLV, WV* (refill)	-	*On until UFS closes. Alarm sounds after 90 sec.
Drain Cycle	FLUSH (Drain)	DV	2 sec.	10 min.

The built-in alarm safeties shut down the unit.

No. of Beeps (every 5 sec.)	Type of Alarm	Reset Options
1	Low Water Safety UFS open > 90 seconds after WV energized.	Automatic reset once water supply is restored and UFS closes.
2	Control Switch In "DRAIN" position longer than 15 minutes.	Automatic reset once the control switch is moved to the "ICE" position.
3	High-Pressure Switch First and second activation in 1 hour.	Automatic reset once pressure drops below the high pressure threshold and the high pressure switch closes.
4	High-Pressure Switch Third activation in 1 hour.	Call for service. To avoid possible catastrophic failure, it is recommended to leave the icemaker off until this alarm is resolved. Manual reset. Turn power off and on again.
5	Freeze Timer WV off > 30 minutes since last WV activation.	Manual reset. Turn power off and on again.
6	Low Voltage (92VAC±5% or less)	"POWER OK" LED turns off if voltage protection operates.
7	High Voltage (147VAC±5% or more)	The control voltage safeties automatically reset when voltage is corrected.
8	Gear Motor CCR contacts fail to close.	Manual reset. Turn power off and on again.
9	IS (BC1) fails (CB S1 dip switch 7 on) MBC (BC2) actuator paddle engaged.	Manual reset. Turn power off and on again.

Legend: CB –control board; CCR –compressor control relay; Comp –compressor; DV –drain valve; FM –fan motor; FMR –fan motor-remote; GM –gear motor; IS (BC1) –infrared sensor; LLV –liquid line valve (MLH model); MBC (BC2) –mechanical bin control; SLV –suction line valve (MLH model); UFS –upper float switch; WV –inlet water valve

**To reset a control board manual alarm, Turn power off and on again.  
If an Alarm occurs, check the following:**

Alarm	Checks	Reset
1 beep	Check external filters, plugged inlet W/V screen, intermittent W/V operation or water control circuit issues i.e. sticking float switch or control board relay issues.	Auto
2 beeps	Check drain switch position, switch contacts or circuit and /or educate customer.	Auto
3 beeps	Check for high ambient or water temperatures, dirty cond., cond. fan circuit issue, intermittent fan motor or bad capacitor, water flow to W/C cond., water regulating valve operation, refrigerant system issue, H/P switch cut in/cut out.	Auto
4 beeps	Same as 3 beep...issue must be resolved.	Manual
5 beeps	Check for sticking F/S, D/V leaking by, evaporator freeze up, refrigeration issue	Manual
6 beeps	Check for low supply voltage, loose connections or brown out conditions.	Auto
7 beeps	Check for high supply voltage, voltage spikes.	Auto
8 beeps	Check for scaled evaporator or auger bearing wear. Evaporator freeze up, refrigeration issues. Check G/M voltage and connections, G/M circuit, blown G/M fuse, control board issue.	Manual
9 beeps	Verify bin control type and dip switch setting, check for sticking or defective bin control.	Manual

## **F-A Control Board Voltage:**

A 24VAC control transformer is connected to the control board to operate the external control components. Internal to the control board is a 5VDC supply for monitoring the following switches during the ice making process: Control Switch (CS), High-Pressure Switch (HPS), Float Switch (FS), Compressor Control Relay/Gear Motor Protect Relay (CCR/GMPR), and Bin Control (2) (mechanical stand-alone or backup). When 5VDC is present across any of these switches, the switch is open.

When checking the board during operation, you could measure 115VAC, 24VAC, or 5VDC depending on the various connector pins. Voltages are not noted on the control board. Use the pictorial board diagram provided in the service manual to determine which voltages are applied to which connectors. Line voltage (115V) is connected to the control board on the X1 (compressor) relay and on K1 connector.

A thorough control board check out procedure is available in the unit service manual.

## **DCM Control Boards:**

Until the F-A control board was developed, DCM models used a series of different control boards. The introduction of the Opti-serve features required additional relays and functions. The F-A control board includes the OS function along with the additional safeties and adjust ability resulting in a universal F/DCM board.

Following is a brief explanation of the control board part numbers used on the DCM lineup.

DCM-270B used control board 4A5591-01 up to serial code C-0 (H). After C-0 (J) serial, it uses the F-A board # 4A2649-01.

The standard DCM control board used on the DCM-300/500/750B models is board # 2A1592-01.

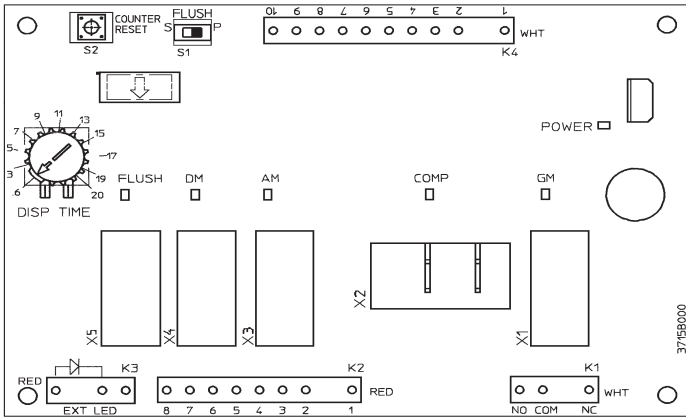

HA # 2A1592-01

DCM-270BAH-OS Serial code > C-0 used control board 2A2867-01.

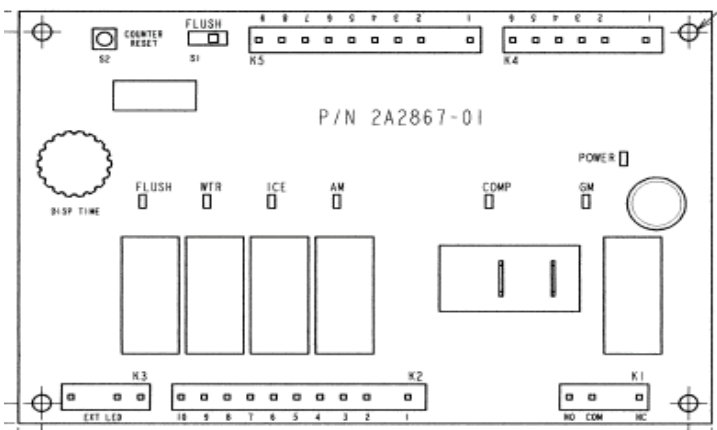

HA # 2A2867-01 or 2A2649-01

DCM-270BAH-OS serial code C-1 and after used the F-A control board # 2A4296-01.

DCM-751B\_H/-OS also use the F-A control board # 2A4296-01.

Interchangeability of the control boards will depend on the serial code and connections. In general, you must use the original control board part number unless it subs. See the appropriate parts manual if you have questions about board part numbers.

## Control Switches:

Flaker models will have 2 control switches.

1. The **Power Switch** controls supply power to the unit.
2. The **Control Switch** will switch the unit from Ice mode to Drain mode.

A third switch is included on the larger DCM's.

The **Dispense Mode Switch** will switch the unit from continuous dispense (ice drops as long as you dispense or 60 seconds...whichever is shorter) to an adjustable portion control. Adjustment is made through a variable resistor on the control board. Continuous or Portion control is switched on by dip switches on new DCM units using the F-A board.

## Evaporator Barrel Heaters:

A band heater is used around the outlet of the evaporator barrel for most cubelet models. This heater warms the extruding head area to prevent ice from bridging and choking the evaporator outlet during shutdown. It also reduces ice squeaking noise which can occur as the cubelet ice passes through a cold extruding head. The heater is energized with the gear motor circuit.

Heaters by Model	Part #
F-330BAH-C	4A4375-01
F-801M-C, F-1001M-C FD-1001M-C, FS-1001/1022M-C DCM-500/751B	4A2292-01
F-1501/2000/2001M-C F/FD-1501M-C	4A4335-01
DCM-750B_H	3U0097-01

## Heater Specs:

Part #	Volts	Watts	Amps	Resistance
*4A4375-01	24V	16W	0.66A	3.6 ± 1.8 Ohms
*4A2292-01	120V	31W	0.26A	464 ± 23 Ohms
*4A4335-01	120V	40W	0.33A	360 ± 18 Ohms
3U0097-01	24V	48W	0.5A	133 ± 6 Ohms

\* Thermally protected 150°F ± 5°F...150°F open, 120°F closed.



## Control Transformer:

Hoshizaki Flaker units include a 24 volt control transformer. This transformer has a 115 volt primary and 24 volt secondary and is protected by a 1 amp control fuse (The DCM has a dual output secondary of 10.5V to terminals K4 - 1 & 2 with a 0.5A fuse and 24V on terminals K2 - 7 & 2 with a 1A fuse). The 24 volt secondary supplies power to: the solid state timer board, relay coils, inlet water valve and flush timer circuit. The flush valve will either be 24 volts AC or DC, depending on the model. A rectifier is provide in the flush valve circuit to convert to 24VDC. Without control voltage on pins 1 and 2, the timer board will not allow the unit to start.

## Gear Motor Protection:

The auger gear motor circuit includes two overload safeties. The primary safety is a manual reset, current type protector, or slow blow fuse located in the control box. This is a time delay protection which operates if high amp draw occurs. The secondary safety is a thermal protector incorporated into the gear motor windings.

The current type gear motor safety has been replaced with a slow blow fuse on most models. The fuse provides more consistent protection in low voltage applications and the correct fuse type and amperage must be used...(time delay or slow blow... not fast acting).

<b>Gear Motor Protection</b>	
<b>Model</b>	<b>Protection</b>
C-100/101B, F-330B, F-300BAF S-1>, F-500BAF >K-0, DCM-270/300/750B	Current type protector
F-450M_H, DCM-500B	2 amp fuse
F-300BAF >S-0, F-800M_H	1.5 amp fuse
F-801/1001M_H(-C), FS-1001/1022M, FD-1001MAH-C, DCM-751B	3 amp fuse.
F-1500/2000/2001M	7 amp fuse/10 A circuit protector

Gear motor failure can be expensive and it is very important to find the cause of the failure when it is replaced. There are several possibilities for the cause of gear motor failure...see Gear Motor Checkout section of this handbook or the unit service manual.

## Internal Auger Design:

Hoshizaki Flakers and DCM's use an internal auger system to provide high quality, crisp flakes and cubelet ice. The evaporator cylinder and auger are made of anti-magnetic stainless steel. This higher quality stainless steel does not attract corrosive minerals eliminating pitting caused by harmful minerals in the water. This maintains a smooth surface to reduce restriction to ice flow providing consistent ice production and quality.

The picture below is a generic representation of the F/DCM evaporator assembly. The extruding head #9 and cutter #10 can be exchanged so that this Flaker assembly will produce Cubelet style (chunklet) ice like the DCM application. The sleeve type alignment bearings are pressed into the housing #4 and extruding head #9. The mechanical seal #6 and o-ring #5 seal the lower end of the evaporator system.

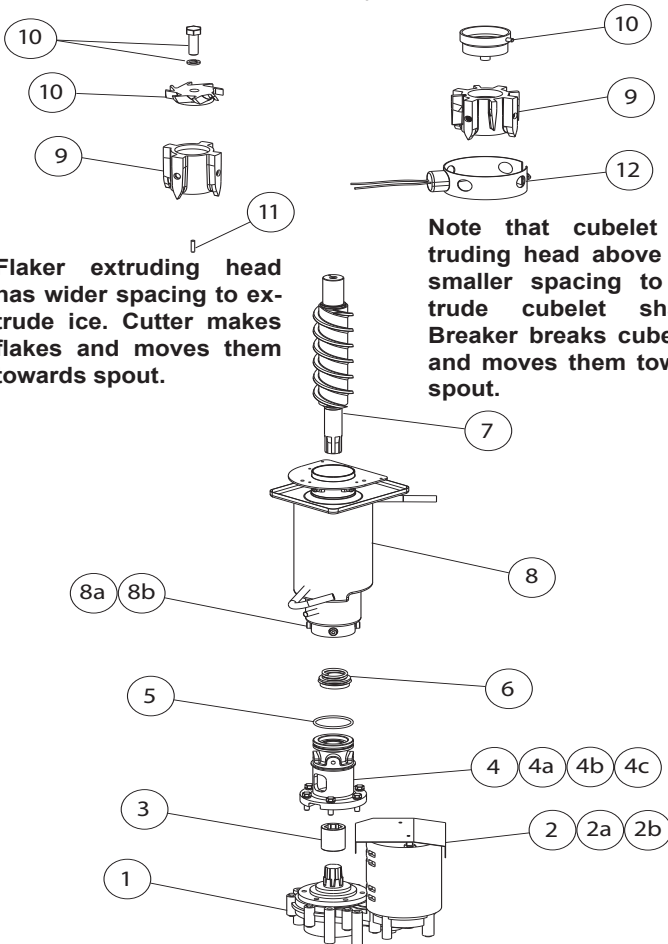

## **Flaker Sequence of Operation:**

The Hoshizaki Flaker utilizes a solid state sequence timer board to switch the components on and off as needed. This sequence of operation is accomplished through a series of timers within the solid state timer board.

### **The sequence for the standard timer board #437305-01/02 and 4A5591-01 is as follows:**

With proper voltage and water supplied to the Flaker and the FLUSH and ICE switch is in the ICE position, power is supplied to the inlet water valve. The unit will not start unless the reservoir is full and both floats on the dual float switch are closed (in the up position). The operation is then turned over to the bin control. If the bin control is closed and calling for ice, the gear motor and condenser fan motor are energized. One minute later, the compressor starts. As the refrigeration system cools the water in the evaporator, ice will start to form within 2 to 5 minutes. This depends on the inlet water temperature and ambient conditions. Ice production will continue until the bin control is satisfied (opens). The shut down process is very simple. On the F-450/801/1001/1500/2000 units, the entire unit shuts down within 6 seconds after the bin control switch opens. On the F-330, 90 seconds after the bin control switch opens, the compressor and fan motor stops, one minute later the gear motor stops.

### **F-A Board Features, Bin Control Selection:**

The F-A board can be used with the infrared sensor bin control by placing S-7 dip switch in the ON position.

A mechanical bin control can be connected and used for a standard storage bin application or for DCM's. The mechanical bin control setting is S-7 dip switch in the OFF position.

### **Periodic Flush:**

Beginning with the F-450M and larger flakers, a periodic flush or drain cycle is included. A 12 hour mechanical timer will cycle the unit down and open the flush valve which allows the complete water system to drain. The unit will remain off for 15 minutes which allows any ice remaining in the evaporator to melt and flush the evaporator walls and mechanical seal out. The inlet water valve is not energized during this flush period. The unit will automatically restart after 15/20 minutes on the flush timer.

The F-330B will flush/drain down when the bin control is open. It is important to remember this when checking a unit.

Depending on the timing, you may need to advance the mechanical timer to start the unit for checkout.

This feature is included in the function of the F-A control board. The mechanical flush timer is eliminated on units that use the F-A control board.

### **F-A Board Flush:**

On the F-A control board, the unit does not shut down to flush. There are 2 setting options available. By switching dip switch 4, the unit will flush/drain as follows:

1. S-4 OFF > Standard setting. The drain valve will open for 2 seconds every hour and the unit continues to operate. This allows sediment to purge while maintaining ice production.

2. S-4 ON > Optional setting. Every 12 hrs. the unit will cycle down and allow for a 10 minute drain cycle.

### **F-A Board Voltage Protection:**

The maximum and minimum allowable supply voltages of this ice maker are limited by the high voltage ( $147\text{Vac}\pm 5\%$  or more) and low voltage ( $92\text{Vac}\pm 5\%$  or less) cut-outs.

When high voltage ( $147\text{Vac}\pm 5\%$  or more) is present, the ice maker automatically stops and the control board signals with a 7-beep alarm every 5 seconds.

When low voltage ( $92\text{Vac}\pm 5\%$  or less) is present, the ice maker automatically stops and the control board signals with a 6-beep alarm every 5 seconds.

This safety automatically resets. When the proper supply voltage is resumed, the ice maker automatically restarts.

### **DCM Sequence of Operation:**

DCM sequence for the ice making unit is similar to the F-330B with a delay of the compressor at start up and a delay of the gear motor at shut down.

A periodic flush is also incorporated in the DCM units. All DCM models also have periodic agitation in the bin to eliminate ice bridging. The DCM-270B model uses a solid state relay to turn the gear motor for .2 seconds every 90 minutes. On DCM-500 /750B models, the solid state timer board will start the agitation motor for 0.6 seconds every 12 seconds of accumulated dispensing time. A full explanation of the DCM sequence of operation can be found in the unit service manual.

## Flaker Timer Board

This standard solid state timer board part #437305-01, is used on all F models and the DCM-270BAH model. It is a simple electronic sequence timer. In order for the board to sequence, certain circuits must be closed. In order to diagnose a bad timer board, it is necessary to check these circuits to assure they are operating properly. If you are trouble-shooting a timer board, the first thing you should check is the incoming control voltage. All Hoshizaki flakers have a 24 volt control transformer. The output of this transformer is protected by a 1 amp buss type fuse. Control voltage comes in the timer board on pins 1 & 2. If you do not have 24 volts at pins 1 & 2, check the transformer and fuse.

After the reservoir fills, check for 24 volts (some models may be 120V) across pins 8 & 2. If voltage is present, the timer board has cycled up to energize the gear motor circuit which indicates there is not a problem in the timer board. If the gear motor does not start, the problem may be in the gear motor relay circuit. Remember that there is a time delay from the time you turn the unit on until the time it cycles up completely. This time will be from 1 ~ 2.5 minutes, depending on the unit model.

In order for the flaker to start up, the reservoir must be full and both float switches must be closed. This closes the control circuit to pins 3 & 4. Do not confuse these pins with the line voltage terminals marked 3 & 4 on the compressor relay located on the board. You can check this circuit with a volt meter across the pins or by placing a jumper across them. If the unit cycles up with the jumper in place, the board is good and your problem is in the water relay control circuit.

**Note:** In self contained models, the bin control will be in series with terminals 3 & 4. Check the bin control operation if this circuit is open and the water control relay is closed.

Next, you should check the bin control circuit at pins 5 & 6. Check for a closed circuit with a volt meter or place a jumper across them. If the unit cycles up with the jumper in place, the board is good and the bin control circuit is the problem.

The last circuit check is across pins 10 & 11. These pins connect to the gear motor protect relay and will shut down the unit if the gear motor fails. Check for a closed circuit with a volt meter or place a jumper across them. If the unit cycles up with the jumper in place, the board is good and the gear motor protect circuit is suspect.

## **Flaker Water Fill System:**

For Standard Timer Board Operation, the reservoir in a Hoshizaki auger type ice maker feeds water by gravity flow into the evaporator cylinder. The level of water in the reservoir is maintained by the operation of the dual float switch.

The dual float switch assembly is made up of two reed switches inside of a sealed shaft. The reed switch contacts are operated by individual magnets attached inside the top of the two separate floats.

As ice is made and extruded from the evaporator cylinder, the water level in the reservoir drops. When the level drops, the top float opens the top switch contacts (considered a latching circuit). Opening these contacts allows the bottom float switch control of the water control relay in the control circuit. As the water level continues to drop, the bottom float contacts open to de-energize the water control relay. You will note that the water control relay is now included on the F-A control board circuitry however the operation is basically the same.

De-energizing the water control relay closes a circuit to supply 24 volts to the inlet water valve solenoid. This allows water to fill the reservoir. It also opens a circuit to the timer board (terminals 3 & 4...internal circuit on the F-A board) which starts a 90 second low water safety shutdown timer.

When the water supply is available, the reservoir refills. As the reservoir level rises, these two switches swap jobs. The bottom float is now the latching circuit and the top float re-energizes the water control relay. When both floats raise, the circuit will stop the safety timer and shut off the water flow to the reservoir.

If no water is available, i.e. the filter or screen is stopped up or the water supply is turned off, the unit cycles down and the water valve remains energized. This same action occurs if the inlet water valve fails. When the water supply is restored, the reservoir fills and the top float switch re-energizes the water control relay to automatically restart the unit. This system provides a consistent water level in the reservoir and evaporator as well as providing an automatic reset low water safety protection.

\*\*Since the float switch is mounted into the water reservoir, it is susceptible to scale build-up. The amount of scale build-up will depend on the local water quality. Scale on the switch shaft can cause the floats to stick. This will effect the unit operation. In this case, the float switch should be cleaned and checked.

# Flaker Sequence Flow Chart (Standard for 437305-01 or 4A5591-01 board)

## 1. INITIAL START UP.

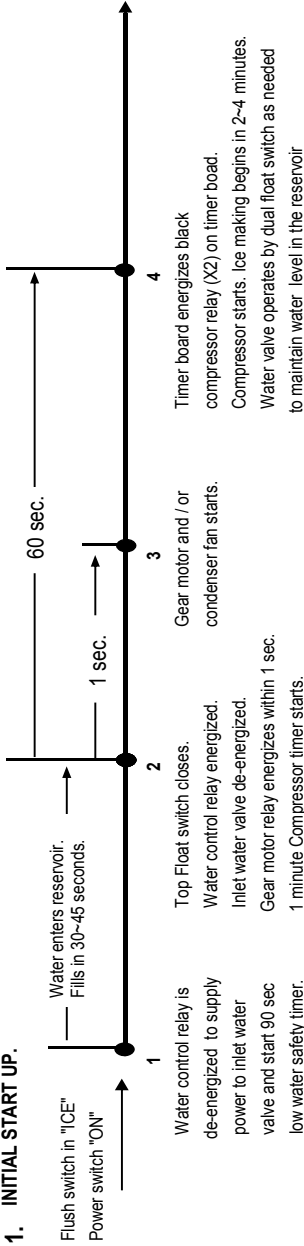

## 2. SHUT DOWN & RESTART

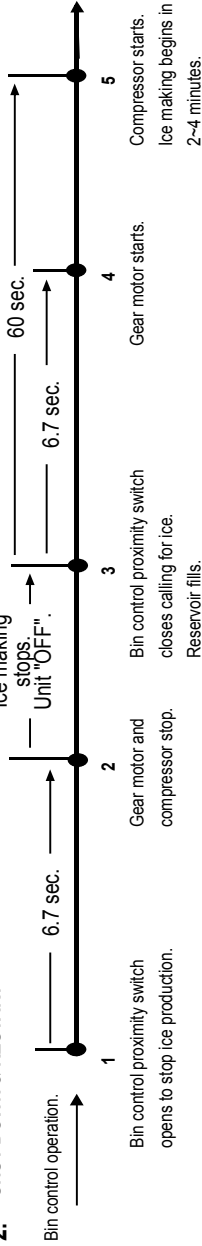

# Flush/Low Water Safety Flow Chart (437305-01 or 4A5591-01 board)

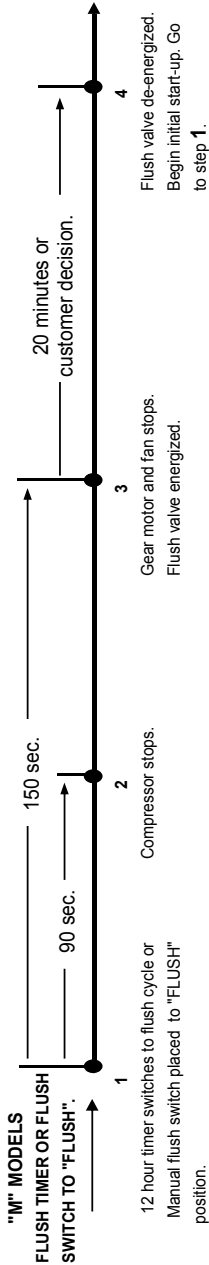

## 4. LOW WATER SAFETY.

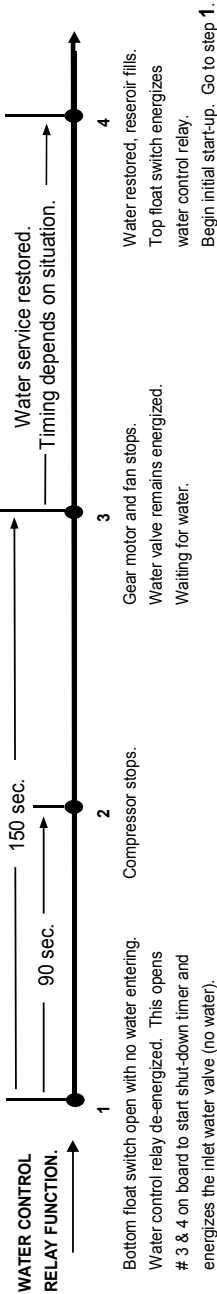



# F-A Bin Control #2 (infrared sensor) Sequence Flow Chart and Operation

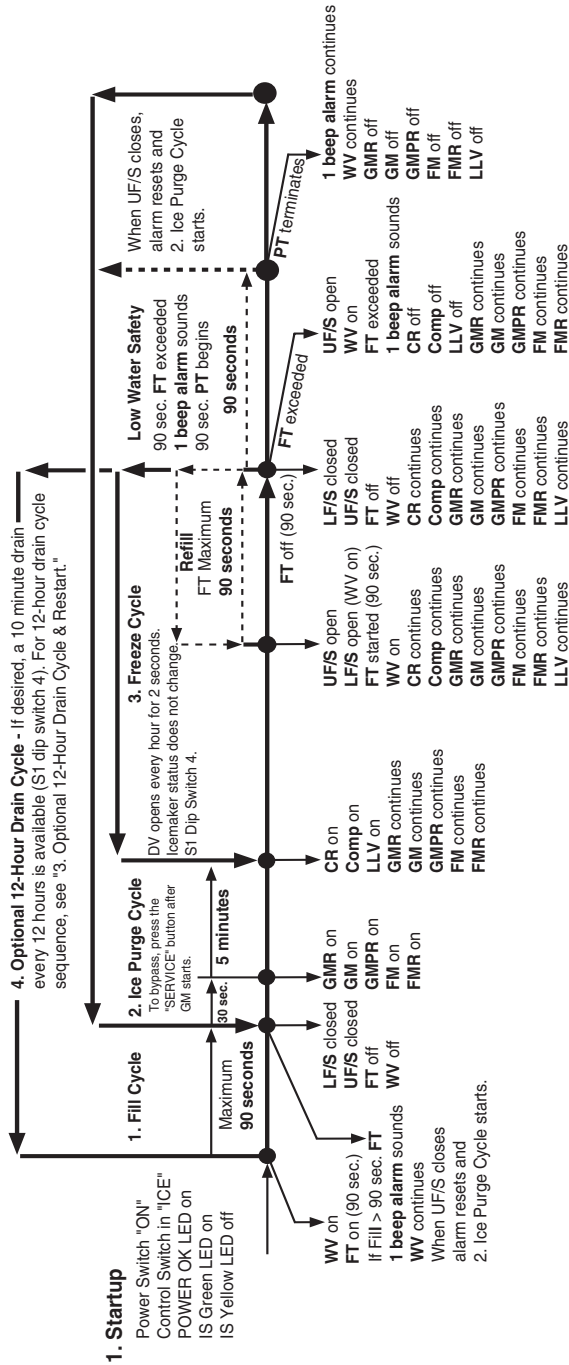

**Note:** When proximity switch bin control is used, step 2 does NOT include 30 sec gear motor delay.

# F-A Bin Control #2 (infrared sensor) Sequence Flow Chart and Operation

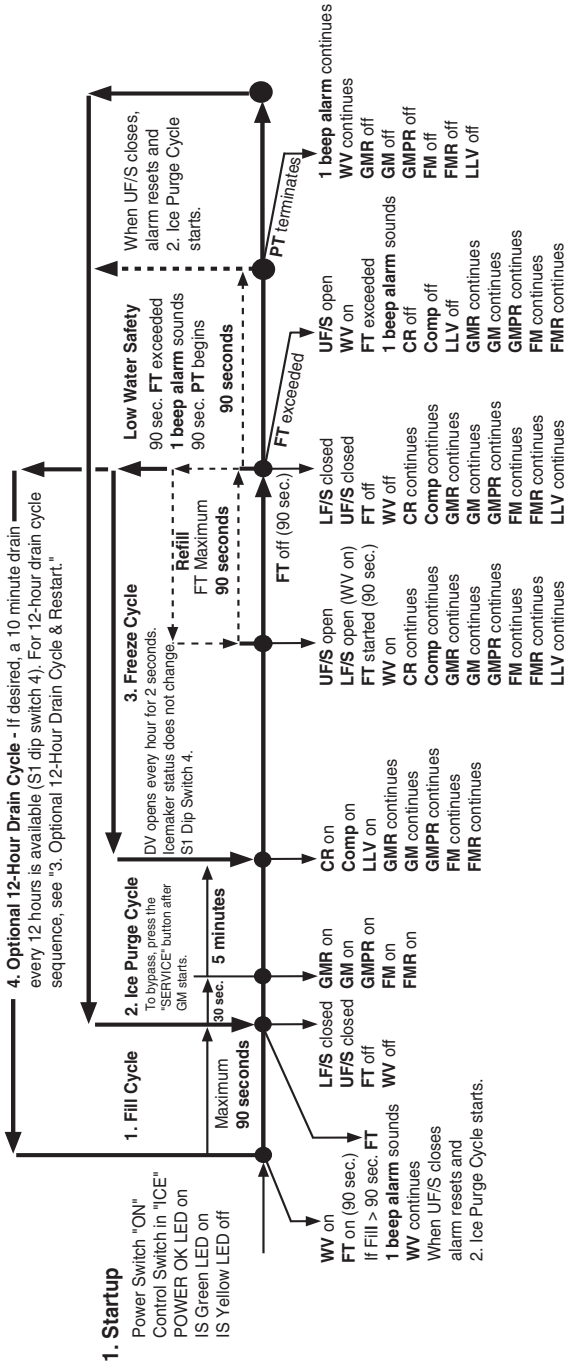

**Note:** When proximity switch bin control is used, step 2 does NOT include 30 sec gear motor delay.

# DCM-300/500/750B\_H 2A1592-01 Board Flow Chart

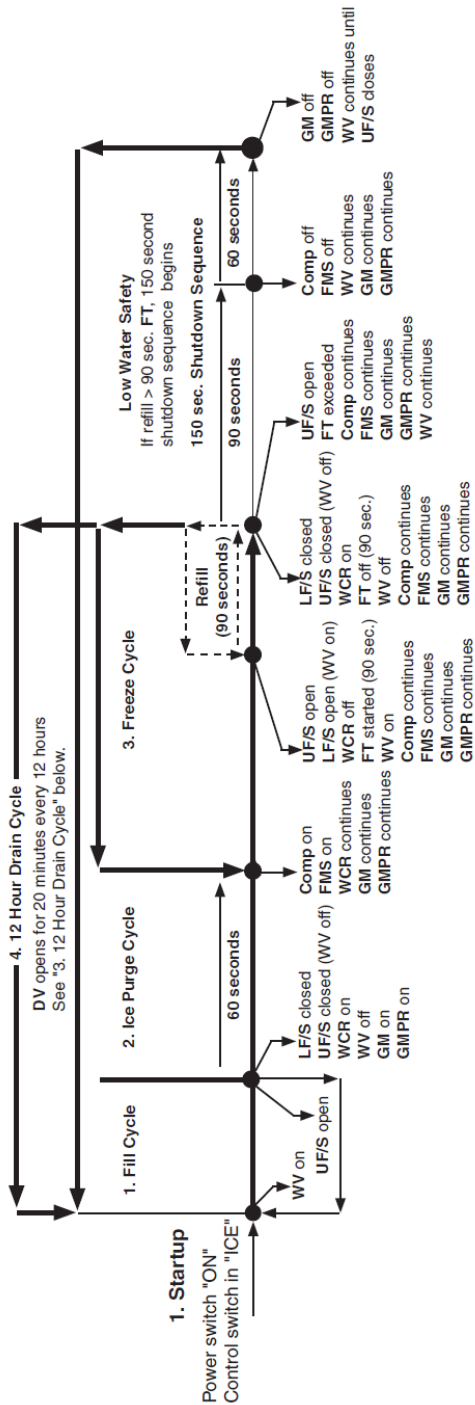

# DCM-500/750B\_H-OS 2A1592-01 Board Flow Chart (continued)

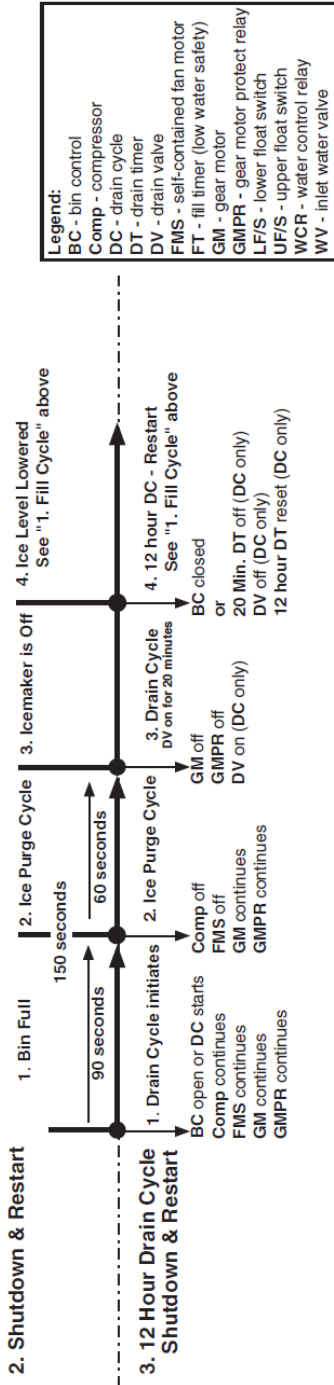

**Components Energized when the Control Switch is in the "DRAIN" Position**

The "DRAIN" position on the control switch is used when cleaning and sanitizing the unit. This allows cleaner and sanitizer to drain from the reservoir and evaporator assembly. When switching to the "DRAIN" position during the freeze cycle, the drain valve does not energize until the 150 second shutdown sequence terminates (2. Shutdown & Restart).

Note: To bypass the 150 second shutdown sequence, move the power switch to the "OFF" position, place the control switch in the "DRAIN" position, then move the power switch back to the "ON" position.

# "F-A" Control Board Sequence Flow Chart DCM-751B\_H(-OS)

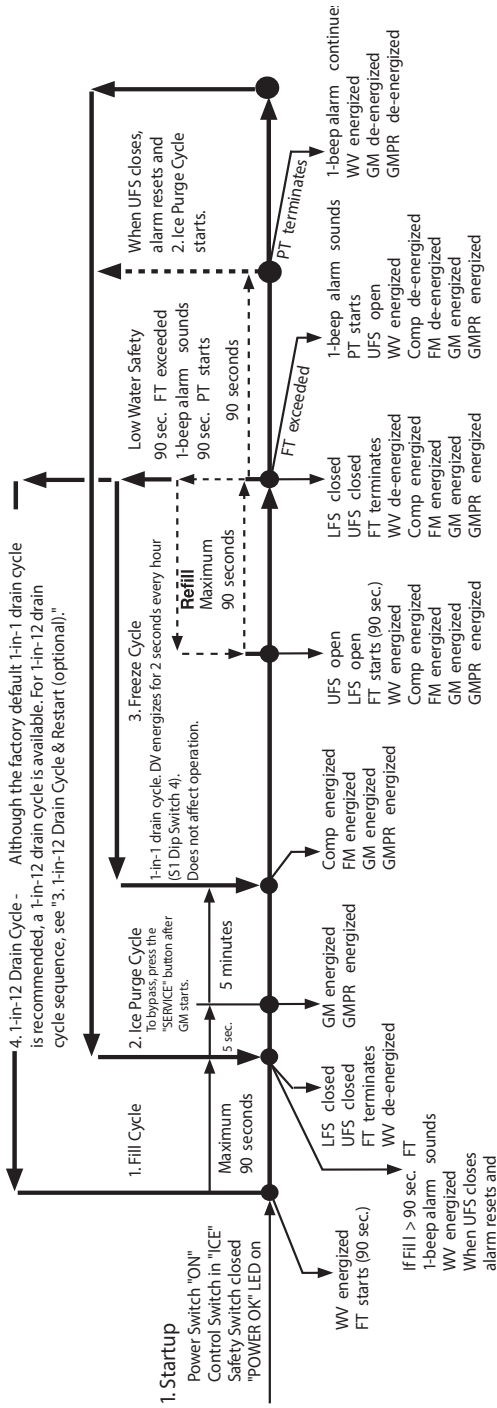

## F-A Control Board Sequence Flow Chart (continued) DCM-751B\_H-OS

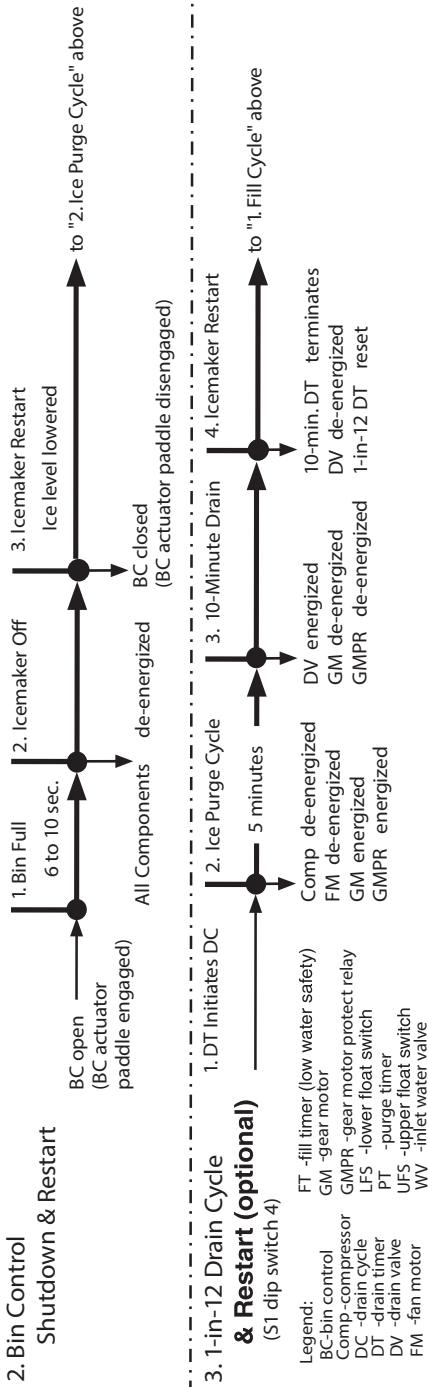

## Component Checkout

### Dual Float Switch:

Hoshizaki float switch, part number 435490-01 can be used as a universal replacement on any Hoshizaki Flaker or DCM model in the field excluding the C-100BAE-AD. It now subs for all previous float switch numbers in our parts system.

Since the float switch is mounted into the water reservoir, it is susceptible to scale build-up. The amount of scale build-up will depend on the local water quality. Scale on the switch shaft can cause the floats to stick. This will effect the unit operation. In this case, the float switch should be cleaned and checked.

The float switch is held in place on the top cover by a twist lock bracket. To remove it, twist the switch flange and lift. Soak the switch assembly in ice machine cleaner. While it is not necessary to do so, some technicians remove the floats from the shaft during cleaning. If you remove them, note that the blue float is on top. Also it is important to clearly mark the top of the floats so that they can be replaced correctly. The magnet side should always be at the top of the float when it is reassembled. (See drawing below). Installing the floats upside down will effect the timing of the float switch operation. Once clean, rinse and wipe the cleaner off and check the switch with a good quality ohm meter.

This float switch has three wires (the black wire is common) and two separate switches. Check the top switch by ohming out the black and red wires. When the float is up the switch should be closed. Check the bottom switch by ohming out the black and blue wires in the same manner. If either switch fails, the assembly should be replaced.

### Dual Float Switch

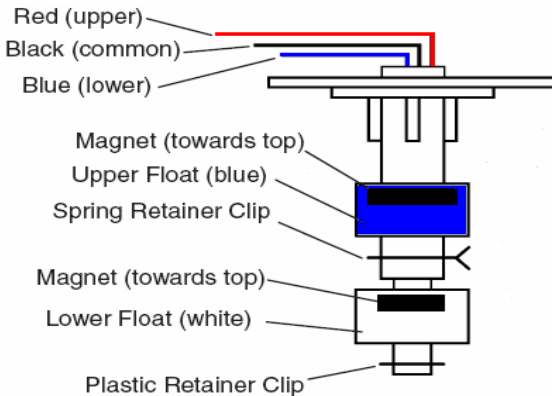

## Flaker Safety's:

Mechanical failures in an auger style ice machine can be time consuming and expensive repairs. Hoshizaki has incorporated several safety's in our Flaker and DCM units which add protection against this type of failure.

The following safety's are included in all Hoshizaki F and DCM units:

1. **Low water safety:** Designed to protect against dry operation or possible freeze up in the evaporator due to low water flow. This safety utilizes the dual float switch and a 90 second timer to shut down the unit when water flow is interrupted. The unit will automatically restart when water flow is resumed.
2. **Protect relay safety:** This safety incorporates a relay in the gear motor circuit and will not allow the refrigeration system to operate unless the gear motor is running. If the gear motor fails during normal operation, the protect relay shuts down the compressor to protect against evaporator freeze-up.
3. **Gear motor circuit safety's:** The gear motor has 2 additional safety's which will operate if the gear motor is subjected to excessive load or improper voltage. A current type manual reset safety or slow blow fuse is located in the control box and will trip when the gear motor amperage exceeds normal amp draw. This acts as a primary safety for the gear motor. A secondary internal thermal overload is included in the motor windings. Both will work in conjunction with the protect relay to shut the unit down.

The gear motor current protector serves as a back-up for the bin control on other models. These safety's protect the Flaker or DCM models from internal failures.

4. **Voltage protect relay:** This relay will shut the unit off in case of a voltage surge and automatically restart the unit when the voltage is correct.
5. **High pressure switch:** All Hoshizaki ice machines include an automatic reset high pressure safety switch to shut down the unit in case of high head pressures.
6. **Fuse protection:** A lamp buss-type fuse is utilized in the control circuit. Smaller units like the DCM-240 and F-300 have a fuse in the incoming power circuit.



7. **Short cycle protection timer:** A 1 minute time delay is included in the start-up sequence to protect against short cycling the gear motor or compressor.

**Note:** The F-A Board has a 5 minute time delay.

8. **Compressor protection** is provided either internally or by means of an external motor circuit protector. This is an automatic reset thermal type overload.

9. Some F-1500/2000 have a **spout safety control** to shut down the unit if the bin control fails for any reason. This is a manual reset safety and will notify the technician by means of a indicator light on the control box. To reset this safety, turn the control switch OFF and back ON. This re-sets the holding relay circuit and turns off the light.

**Note:** This feature was removed from F-1500/2000M in late 2009 production and after.

Additional safeties are featured in the new universal F-A control board.

10. During normal operation, a **freeze up protection** will shut the unit down on the manual reset safety and sound a 5 beep alarm if the inlet water valve does not open within 30 minutes of the last activation.

11. Additional **gear motor protection**... In conjunction with the #3 gear motor safeties, the unit will shut down on the manual reset safety and an 8 beep alarm will sound if the gear motor protect relay fails to energize.

12. **Bin control protection**...If the secondary mechanical bin control actuates, with the bin control selector switch in the ON position, the unit will shut down on the manual reset safety and a 9 beep alarm will sound.

13. **Short cycle protection**...The F-A board has an automatic ice purge cycle which allows the gear motor to start 30 seconds after the reservoir is full and delays compressor start up for 5 minutes. This allows the ice to be removed from the evaporator before the compressor starts if the bin control reactivates quickly. This feature can be bypassed for diagnosis by pressing the "Service" button after the Gear motor starts.

## **Gear Motor Checkout:**

The following check list is designed to help you find the reason your gear motor failure occurred.

**1. Normal Amperage:** The amperage for gear motor should be listed on the nameplate. Answer the following questions to discover the possible cause for your failure:

1. Is Ambient Temperature above 45 degrees F. (Cold water causes GM stress and higher amp draw.)
2. Does the unit have the wrong Extruding Head. Check the Extruder Type. Is it a Flaker or Cubelet style. (The cubelet style head will have smaller openings for the ice to extrude.)
3. Does the unit have the wrong Cutter. The cutter should match the extruding head style. Flake or Cubelet.
4. Do you have a Damaged Extruder. Look for the following imperfections. A. Dents, B. Fins Bent, C. Scale, D. Other Resistance.

**Note:** A dirty, or scaled up, evaporator increases stress and can cause the gear motor overload to trip or fuse to blow.

5. Does the unit have the Correct Auger. Is the auger a dual flight auger? (Double Spirals) Check the parts breakdown for the correct auger style.
6. Check the Voltage Supply and circuit amperage. Is this unit on it's own dedicated circuit? The supply voltage should be within  $\pm 10\%$  of the rated voltage when the unit is making ice.
7. Check the Running Voltage at the gear motor. (While the unit is making Ice.)
8. Inspect bearings for wear. (Use bearing gauge) Are the bearings OK? If the upper bearing is worn, both bearings should be replaced.
9. Check Evaporator Cylinder/Barrel for signs of scoring. (The auger flights should never contact the cylinder.)
10. Is there any condensation dripping onto the Gear Motor windings? If yes, find the source and take action to stop the moisture.
11. Is the galvanized shield mounted over the motor assembly to protect from moisture?
12. Verify that you have the proper Gear Motor Capacitor.
13. Is the Gear Motor Locked.
14. Check motor winding resistance.

**2. Wrong Gear Motor Overload/Fuse:** Check fuse size. Has the original overload reset been replaced with the wrong size and type fuse? The Flaker requires a slow blow type fuse. Replacing it with a standard fuse will cause the fuse to blow again.

**Note:** Although it is common practice to install a larger fuse

during service diagnosis, ***you should not leave a larger fuse in the unit when you leave the site.*** This could cause a serious unit failure/twist-up.

**Note: *You should never jumper the fuse protector!***

### **3. Miswiring**

Is gear motor wired correctly and wire connections tight. Check the wiring diagram for the proper wiring.

### **4. Bin Control Switch Does Not Operate**

Check the bin control operation. A bad or miswired bin control can cause ice to back up in the spout and chute and cause higher gear motor amperage. Is bin control wired correctly and are the wire connections tight?

Make sure there are no metallic components interfering with the magnetic bin control. Verify top panel is non-magnetic. Assure that the proximity switch is mounted properly. The switch must be secure and mounted level to the chute top. Does the bin control paddle move freely and is it unobstructed?

### **Gear Motor Stress**

As you can see, there are many factors that can cause a gear motor to fail. Every effort should be made to determine the cause for a gear motor failure when the gear motor is replaced. When looking for the cause of a gear motor failure, you should consider anything that will add stress to the assembly. Stress on the gear motor will increase the gear motor amperage and torque. The most common causes for stress is scale on the auger surface and evaporator walls. Scale insulates the evaporator walls and causes reduced heat transfer. As a result, the ice will be wet and mushy. This poor quality ice does not extrude well and tends to pack in the evaporator outlet and extruding head increasing gear motor stress.

Heavy scale build up must be removed using an acid based cleaner which will loosen the scale. Follow the cleaning instructions provided on the cleaning label to preform a maintenance cleaning. If the unit has not been cleaned and maintained frequently, it may require you to pull the auger and clean the cylinder wall with a Scotch Brite pad & cleaner. The extruding head surfaces may also have heavy scale and can be cleaned with Scotch Brite & cleaner as well.

***\*\*Loose bolts on the gear motor, housing, and extruding head can also cause stress. Always check to assure they are secure when conducting preventative maintenance.***

## Seal Bolts:

The extruding head is secured in the outlet of the evaporator barrel with seal bolts. The seals are important to maintain a leak free evaporator assembly. The seal will compress when the bolts are properly tightened and prevent leaks. The seals are one time use. The seal bolts should be replaced and properly torqued if removal or replacement of the auger extruding head is required.

\*\*Seal leaks will result in visible scale trails from the bolt heads.

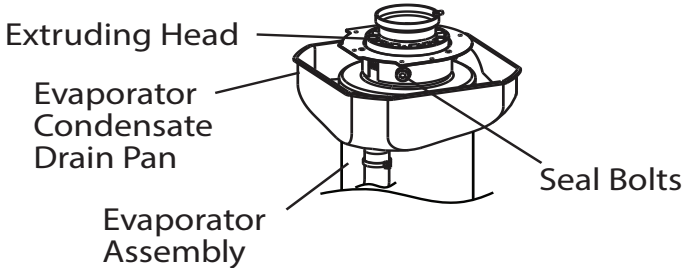

## Bolt Torque Spec in ft/lb / N/M

Models	Cutter bolt	Seal bolt	Housing bolt	Gear motor bolt
C-100/101B, F-300/330/450/500B/M, DCM-240/270B, DT-400B	7.4/10	11.1/15.1	3.8/5.2	7.4/10
F/FD/FS-650/800/801/1001/1022M, DCM-450/500/750/751B	7.4/10	11.1/15.1	7.4/10	14.8/20.1
F-1500/2000/2001M, DCM-750B	9.62/13.1	25.8*/35	14.8/20.1	14.8/20.1

\*Extruding head bolts must be torqued to 25.8 ft/lb twice with at least 2 minutes between application to compensate for seal relaxation.

Order seal bolts by part number and keep spares on hand if you service auger products.

Models	Part #
C/100/101B, DCM-240/270/300/450/500/751B, F-300/330/450/500/800/801/1000/1001B/M, FD-650/801/1001M, FS-1001/1022M, DT-400B	P01768-02
F-1500/1501/2000/2001M, DCM-750B, FS-1500M	474757G02

See service bulletin SB10-0005R3 for additional details.

## **Auger Bearings:**

***Bearing Type: Sleeve/Alignment,***

***Bearing Material: Poly/Carbon***

The bearings are pressed into the top extruding head and lower brass housing. A bearing repress program is available through the local Hoshizaki Distributor for undamaged extruding heads and housings. ***The bearings should always be replaced as a set to assure correct alignment and even wear.*** Return the extruding head and housing to your distributor for an exchange set or to be returned for repressing.

## **Bearing Inspections:**

It is important to remember that bearings are a wear item. Annual bearing inspections are recommended. More frequent inspections may be necessary in poor water quality areas. The steps for bearing inspections are as follows:

- (1 ) Gain access to the ice chute head by removing the top panel and spout connectors as necessary. Use warm water to melt any ice in the evaporator if ice is present.
- (2) Remove the thumb nuts which hold the ice chute head in place and lift it up and off of the evaporator (take care to place the O-ring in a safe location until you replace the ice chute head.)
- (3) Remove the stainless steel bolt holding the cutter or breaker in place and lift off to access the extruding head and auger shaft.
- (4) Replace the bolt into the auger shaft and use it to push the auger back and forth from left to right to check for excessive movement.
- (5) Pull the auger towards you and try to insert a .02" round stock or pin gauge in between the back side of the auger shaft and bearing surface. Check several locations around the auger shaft. If the gauge will go in between the shaft and bearing surfaces, it is time to install new bearings. Both top and bottom bearings should be replaced if the top bearing is worn. If there is no excessive movement in the auger shaft and the gauge does not fit, the bearings are okay. Replace the cutter, o-ring, ice chute head and connectors.

***Note: Flat gauges may give a false check as they will not insert in the circumference of the barrel.***

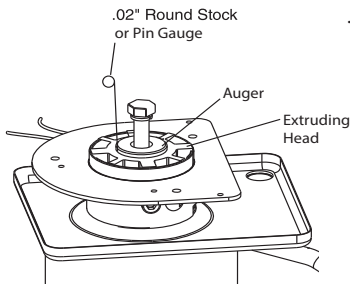

**Checking bearings on evaporator with original drain pan.**

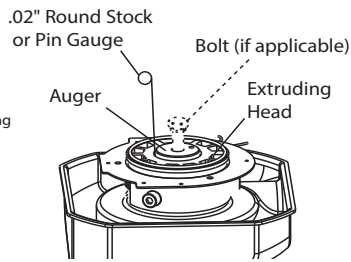

**Checking bearings on evaporator with new drain boot.**

Note: Do not pull upwards on the evaporator drain pan. If drain pan seal is broken, reseal with silicone.

### Mechanical Seal:

Hoshizaki auger products utilize a heavy duty, high speed, ceramic to carbon mechanical seal. This seal is located at the bottom of the evaporator and maintains the water seal between the barrel and housing. If it leaks, you will see a water trail from under the housing and over the gear motor assembly.

The seal is reusable if it is clean and not damaged. Inspect the seal surfaces for cracks and pitting, assure it is clean and scale free and reuse or replace as necessary. To avoid damage caused by dirt or grit, clean any fingerprints off the seal surfaces and do not use lubricant when reusing or replacing the mechanical seal.

A second seal is the O-Ring that seals the barrel to the housing. If it leaks, you will see a trail of water running from the evaporator and down the outside of the brass housing. It is recommended to replace this o-ring if the barrel is separated from the housing during service. Use a touch of food grade grease or silicone spray to lubricate the o-ring and barrel bottom during replacement to prevent roll-up.

There are only three size mechanical seals and o-rings currently used...other part numbers will sub to these depending on the barrel circumference.

### Mechanical seal and o-ring part numbers:

Model	Barrel Size	Mech Seal Part #	O-Ring Part #
DCM-240/270/300, C-100/101B, F-300/330/450/500	045mm	432491-01	4A4755-01
DCM-500/751, F/FD/FS-800/801/1000/1001/1022	070mm	432492-01	4A4755-02
DCM-750, F/FS-1500/1501/2000/2001	095mm	432493-01	4A4755-04

## Water Solenoids:

DCM products include three solenoid valves. The inlet water valve and the dispense water valve are the same part number. The Drain valve is a different valve.

The inlet water and dispense valves have 80 mesh screens in the inlet to catch trash and debris. Screens should be cleaned or replaced during preventative maintenance. Replacement screen part number is SA-0019.

A washer or packing is used to seal the inlet water valve and dispenser valve connection. Always assure that the washer is OK and in place when reconnecting the valve.

### Inlet water/dispense valve current part number:

Models	Part #	Coil ohms	Washer #
C-100/101	4A5251-05	1.14K ohm ± 10% @25°C	413854-03
DCM-270 DCM-300/500/750/751, F-300 >V-1, F-330 >A-0, F-450/500/800/801/1000, FD-1001, FS-1001/1022, F-1500 > A-1, FS-1500M >B-0, F-2000 > B-0	4A0865-01	22 ohms ± 10% @25°C	4A0867-01
F-300 V-2>, F-330 FD-650, FD-1001M_H-C/M_J-C, F-1001M_H/J, F-1500 A-2>, F-2000 B-1>, F-1501/2001	4A5309-01	55 ohms ± 10% @25°C	413854-03

Check coil with an ohm meter to verify windings are OK.

### Drain Valve part numbers:

Models	Part #	Coil Ohms
C-101,	4A5530-03	1270 ohms ± 10% @25°C
DCM-270/300/500/750/751, F-300/330/450/500/800/801,1000/1001, F-1501/2001	4A2772-01	46 ohms ± 10% @25°C
F-1001M_J, F-1501, F-2001	4A2772-02	46 ohms ± 10% @25°C

## Auger Inspection / Bearing Replacement

A visual inspection of the auger bearing shaft surface is recommended annually in poor water areas. The steps for this inspection is as follows:

**Note:** If heavy scale is present the auger may be difficult to remove. In this case, you will find it helpful to soak and clean the evaporator system following the instructions provided before you attempt to remove the auger.

- (1) Follow steps 1 through 5 of the bearing inspection procedure.
- (2) Remove the (metric) socketallen head cap screws with seals that secure the extruding head in place.
- (3) Thoroughly drain the water supply system.
- (4) Turn the cutter up-side down, replace the bolt and use the cutter to lift the auger out of the evaporator.
- (5) With the auger removed, remove the cutter and slide the extruding head from the top of the auger. Visually inspect the bearing surface at the top and bottom of the auger. Also inspect the auger flight and mechanical seal for any damage. The extruding head contains the top bearing. The bottom bearing is pressed into the brass housing at the bottom of the evaporator.
- (6) To remove the housing: Remove the allen screws that secure the evaporator to the housing.
- (7) Loosen the belly band screw and lift the evaporator up and off of the housing. Holding the evaporator up, retighten the belly band. This will hold the evaporator up so that you can remove the housing.
- (8) Remove the bolts that secure the housing to the gear motor assembly and remove the housing. The mechanical seal, ceramic disk and boot are pressed into the top of the housing. Remove these parts before you exchange the bearings. Exchange the extruding head and housing for a repressed set at your local distributor. To replace the new parts, reverse the order above. Use a light coat of food grade silicone lubricant around the inside bottom of the evaporator and on the o-ring to and help keep it in place as you lower the evaporator. *Do not use mineral oil as it may damage the o-ring material.*

\*\*Be sure to **use new seal bolts and torque** them properly.



## **Flaker/DCM Production Check:**

Performing a production check is an excellent way to prove proper F/DCM operation. A production check on these models is a simple process.

To check the production you will need a small trash bag, dish tote, bucket or pan to catch the ice and a set of scales to weigh the ice.

For best results, you should always check production on a unit that has a cold evaporator. After the unit has operated for 10 to 20 minutes, catch the ice production directly from the evaporator for 10 full minutes. Weigh the ice to establish the batch weight. Multiply the batch weight by 144 for the total production in 24 hours.

Some technicians prefer to catch the ice for 20 minutes and multiply the weight by 72 for a more realistic production check. It is true that a longer catch is more accurate however, it doubles your test time and may only show a 1 to 2% difference in total production.

Once you know the 24 hour production, check it against the unit specifications for your ambient and inlet water conditions on the performance data chart provided in this handbook. If the production is within +/- 10% of the data on the chart, the unit is operating within spec.

Formula for 10 minute catch:

$$\text{Ice weight} \times 144 = 24 \text{ hour production}$$

Formula for 20 minute catch:

$$\text{Ice weight} \times 72 = 24 \text{ hour production}$$

The most efficient operating conditions for an ice maker is 70°F air temperature and 50°F water temperature. The performance data charts show a wide range of operating conditions. For accuracy, be sure to physically check the air and water temperatures at the ice maker and use these to find the expected production and operating parameters for your model on the performance data charts.

It is important to understand that ambient and water temperatures affect ice maker production. Ice production will decrease as ambient and water temperatures increase. Good air flow around the unit is important for achieving the best efficiency.

## **Preventative Maintenance:**

Preventative Maintenance is the key to long equipment life and maximum efficiency. Hoshizaki recommends performing the following maintenance steps annually. The PM frequency will depend on the local water quality and operating conditions.

### **Preventative Maintenance Steps:**

1. Clean the removable air filter. Hoshizaki air-cooled units include a front accessible and cleanable air filter. This filter collects dirt, dust, and grease. It can be cleaned with warm soapy water. Hoshizaki recommends cleaning the air filter twice a month or more, depending on conditions.
2. Service the external water filter system (if equipped) and check and clean inlet water valve screen.
3. Clean and sanitize the water system and bin. A cleaning label with detailed instructions is usually located on the inside of the front panel.
4. Check bearings on Flaker/DCM annually, for wear. Pull the auger and inspect evaporator, auger, and bearing surfaces for wear. Bearing inspections may be needed more frequently in areas with poor water quality.
5. Visually inspect the unit for loose wires, oil spots, scale trails, water drips, etc.
6. Clean & wipe exterior with a soft cloth and neutral cleaner.

### **Stainless Steel Cleaning:**

Water quality is constantly changing and local municipalities are now adding higher levels of chlorine, chloramine, and sometimes chlorine dioxides to reduce bacteria in the water. Stainless steel is a durable metal however, it can be susceptible to corrosion due to exposure to chlorine gas.

As ice forms, chlorine outgases and settles to the lowest point in the bin. This gas sticks to wet surfaces and around the door opening of the bin to form hydrochloric acid. If this acid remains on the stainless steel, rust colored corrosion occurs. With enough exposure, the corrosion can pit and damage the stainless.

If rust colored corrosion is found, it should be cleaned thoroughly with a non-abrasive cleaner and protected with a stainless steel polish. Heavy corrosion will require some effort to remove and may require the use of a cleaning agent like “Brasso” or non-abrasive powdered cleaner like “Zud” or “Bon Ami”. Care should be taken so as not to scratch the stainless during the cleaning process.

## Cleaning/Sanitizing Procedure:

Cleaning and sanitizing an ice maker extends the service life and improves unit efficiency. Hoshizaki recommends that auger type ice makers be cleaned and sanitized at least twice a year. More frequent cleaning and sanitizing may be required in some conditions.

A maintenance label that details the step by step cleaning/sanitizing procedure is located somewhere in the unit. It is generally located on the inside front panel or under the top panel. These instructions are also provided in the Instruction Manual shipped with each unit or can be downloaded at <http://hoshizakiamerica.com/support/>. Follow these instructions to conduct a thorough cleaning and sanitizing of the water system.

### Cleaners:

Hoshizaki recommends “Hoshizaki Scale Away” or a similar ice machine cleaner however, any FDA approved ice machine cleaner with a 28%~30% phosphoric acid solution is acceptable. If you carry a nickel safe cleaner it is important to note that if it contains a citric acid, it is not recommended for Hoshizaki products as citric acid can affect tin solder.

Recommended Cleaning Solution Mixture		
Model	Cleaner	Water
C-100/101B	1.6 Fl oz	1 Qt
All F/FD/FS/DCM Models	9.6 Fl oz	1.6 Gal

### Note: Do not use a stronger solution for F/DCM's.

Chart shows minimum solution amounts for cleaning.

Remember that scale impedes heat transfer. Heavy scale will result in soft wet ice, low production and may cause squeaking or squealing noise due to extruding the poor quality ice.

If there is excess scale, fill the evaporator assembly and reservoir with cleaning solution per the instructions, then use a clamp on the reservoir hose between the reservoir and evaporator assembly to block flow. Pour additional cleaning solution over the extruding head until the evaporator assembly is completely full. This will soak all evaporator parts to loosen scale.

If the unit has not been cleaned or de-scaled for a long period, it may be necessary to pull the auger and use a Scotch-brite pad. Use vertical motion to remove heavy scale from the evaporator barrel surface.

## Additional Cleaning: Inlet Water Valve Screen

The inlet water valve includes an 80 mesh screen to protect the water system from debris. Always check and clear this screen during the cleaning procedure.

## Air filter

A removable, cleanable mesh air filter is included on self-contained air cooled units. A dirty air filter will cause high head pressure and reduce production. Clean the filter twice a month with warm soapy water to assure proper air flow.

## Other cleaning

In addition to cleaning the reservoir and water distribution system, other items should be cleaned with cleaning solution and rinsed thoroughly. The reservoir and float switch should always be cleaned. Drain the reservoir and clean and inspect the float switch assembly. Make sure the reservoir is thoroughly flushed prior to advancing to the sanitizing step. Use additional cleaner to clean spout and removable parts.

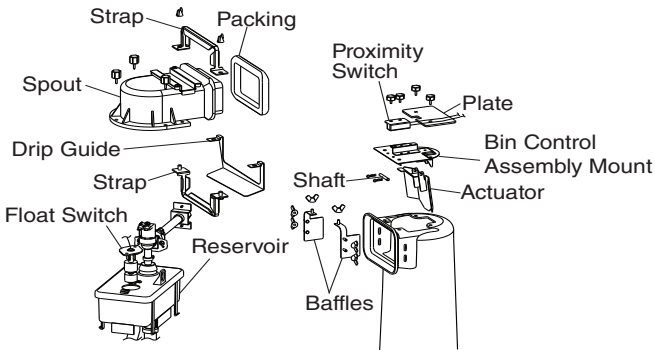

## Sanitizing:

The system should be sanitized using a solution of water and 5.25% sodium hypochlorite (chlorine bleach). Any commercial sanitizer recommended for ice machine application is acceptable.

**Remember: Never mix cleaner with sanitizer!**

Recommended Sanitizing Solution Mixture		
Model	Sanitizer	Water
C-100/101B	1.25 Fl oz	2.5 Gal
All F/FD/FS/ DCM models	2.5 Fl oz	5.0 Gal

## **DIAGNOSTIC TIPS:**

### **WATER SYSTEM:**

1. Scale buildup will impeded heat transfer and effect ice production and quality. Scale will also cause sticking components such as a sticking mechanical bin control or float switch. In the case of poor ice production, poor ice quality or intermittent MBC or F/S operation, do a thorough cleaning before diagnosing a failed component.
2. Always check and clean the inlet water valve screen during PM's.
3. Check water flow and pressure to the ice maker during the reservoir fill cycle. Assure good water flow to the ice maker by checking the pressure guage reading of the water flowing to the ice maker rather than just reading the static pressure on the filter.
4. Replace filter cartridges routinely as needed.
5. If you are loosing water and short cycling the water fill, look for water leaks from hoses, drain valve leaking by or mechanical seal and o-ring leaks at the base of the evaporator barrel.

### **ELECTRICAL SYSTEM:**

Ice makers and other refrigeration systems require a separate independent power supply.

1. Always check for proper voltage prior to start up or attempting to diagnose an electrical issue.
2. Loose connections will cause voltage drops and high current/high heat. Check to assure all power supply connections are tight to assure proper voltage.
3. Always check for loose terminal connections to various components. Loose connections could allow voltage readings but not carry the circuit load.

Checking the center tap (neutral/power) transformer is unique. The transformer provides the 120 volt control circuit on 208/230V models on 3 phase and 3 wire application units. It is included to eliminate the need for a 4 wire dedicated neutral circuit. The output of this transformer should read 120V from the primary connection (marked 0V) to the white center tap. You should always check this control voltage to a white wire and not to the customary case ground. If you check from the white wire to case ground, you will read approximately half the control voltage (52 ~ 66V). This can be confusing unless you understand that this is the characteristic of the center tap transformer application and does not represent a defective center tap transformer. Note that

a reading of 120V to case ground indicates a potential shorted transformet winding condition. The most common electrical component issues are blown fuses or issues with the thermostat bin control, control switches or relays.

### **REFRIGERATION SYSTEM:**

It is important to remember that an ice maker is a close-coupled refrigeration system and has a critical refrigerant charge. The only way to properly charge an ice maker is to evacuate and weight the nameplate charge back in.

1. The charge should never be topped off.
2. Putting gauges on the system should be the last step in diagnosing refrigeration issues. Always pre-check system for obvious issues prior to installing gauges.
3. Scale on the evaporator and dirt on the condenser will affect proper operating pressures. The system should be clean before attempting to check pressures and diagnose a refrigeration issue.
4. Good information can be gained by using the touch and feel method during the cycle. Always check for unusual hot or cold spots around suspect components such as valves, driers, heat exchangers and the inlet and outlet of the condenser and evaporator.
5. Use performance data provided in this handbook to determine if the refrigerant system is operating properly.
6. Do not guesstimate the air and water temperatures. Accurate temperature data is needed to properly cross reference the performance data.

### **LEAKS:**

1. If you suspect a refrigerant leak, use proper leak checking techniques.
2. Look for oil spots around joints and connections and use the proper leak detector.
3. Increase the system pressure by masking the condenser or disconnecting the condenser fan motor for a few minutes during leak check.
4. If you find a leak, you should always recover the remaining refrigerant, make your repair and change the drier. Then evacuate the system and recharge to nameplate rating.

**Note: *The drier should be replaced any time the sealed system is serviced.***

### **THERMOSTATIC EXPANSION VALVE (TXV):**

If you suspect a TXV issue and are confident that the evaporator and condenser are clean and the system charge is correct, following is a quick check to help in the diagnosis. Remember, a low charge or dirt and scale can cause misdiagnosis.

1. For a single TXV model; with the unit running, disconnect the TXV bulb and warm it using a cup of hot tap water. Watch for the pressures to increase when the load is increased by the warm temperatures. Next, cool it in a cup of ice water. Watch for a *consistent* swing of 15 to 30 psig. If the pressures remain constant or are slow to change, the TXV is likely bad and should be replaced.

2. For a dual TXV model, the swing test will not apply. With the unit running, check the temperature difference at the valve outlets and compare them. Expect a small difference of  $\pm 2^{\circ}\text{F}$ , however, an excessive difference in inlet and outlet temperatures will point you to a defective TXV. If one valve is not feeding properly, both should be changed out. This is to assure there is no damage or weakness in the other valve so that the evaporator will have a consistent refrigerant flow after the repair. Bulbs should be remounted properly and securely in the same location.

### **EVAPORATOR FROST TEST:**

**Note:** We recommend conducting this test prior to changing out a suspected weak compressor as the symptoms are the same. It could mean the difference in changing out a non defective compressor and finding the same symptoms.

If you suspect a problem with the evaporator, a quick frost test can be done to aid in diagnosing the problem. The symptoms would potentially be...icing on the outside of the evaporator insulation or unexplained low production. The pressures read close to normal and the TXV is feeding but production is lower than the customary  $\pm 10\%$  allowance... maybe around 20~50%. There is a rare potential for an evaporator restriction or separation of the tubing from the evaporator barrel...especially on an older evaporator.

For the frost test, you need to examine the frost pattern in the barrel. To do this:

1. Turn the water off to the unit and drain the reservoir.
2. Pull the extruding head and auger.
3. Remove the float switch and turn it upside down to assure both switches are closed. This will allow the unit to start up with no water in the system.
4. Turn the unit to ICE and allow it to cycle up. On the F-A board, press the service button to skip the 5 minute ice purge cycle. Remember, the gear motor will turn for a period before the compressor starts.
5. When the compressor starts, watch the frost pattern inside

the evaporator barrel. You should see a consistent growth of frost from bottom to top. Note that on the smaller barrel, the frost may start at the top even though it feeds from the bottom because the small barrel floods initially. Consistency in the frost pattern is the key. If you see gaps or spaces with no frost, separation is likely. In the case of no frost, the TXV, low charge or inefficient compressor is more likely. Repeat this process a couple of times to assure proper diagnosis.

## **Flaker/DCM Water/Refrigeration Circuit**

### **Drawing Reference List:**

Refrigeration and water circuits are helpful to trouble shoot and diagnose issues with water and refrigerant flow. Many models have similar layouts and some drawings have been combined to represent more than one model.

<b><u>MODEL</u></b>	<b><u>DRAWING PAGE</u></b>
C-101BAH.....	A.....313
DCM-270BAH-OS.....	B.....314
DCM-500BAH/BWH-OS	
DCM-750BAH/BWH.....	C.....315
DT-400BAH-OS.....	D.....316
F-300BAF, 330BAH.....	E.....317
F-500BAF.....	F.....318
F-450MAH, F-800MAH/MWH, F-801MAH/MWH, F-1001MAH/MWH, FD-1001MAH/MWH, F-1500MAH/MWH.G.....	319
F-1001MRH, FD-1001MRH-C.....	H.....320
F-1001MLH-C.....	I.....321
FS-1001MLH-C.....	J.....322
F-1500MRH.....	K.....323
FS-1001MLH-C, FS-1022MLH-C, F-1501MLH-C.....	L.....324
FD-650MAH-C, FD-1001MAH-C, F-1001MAH-C, F-1501MAH-C.....	M.....325
FD-650MWH-C, FD-1001MWH-C, F-1001MWH-C, F-1501MWH-C, F-2001MWH, F-2001MWH-C.....	N.....326
FD-650MRH-C, FD-1001MRH-C, F-1001MRH-C, F-1501MRH-C, F-2000MRH, F-2001MRH-C.....	O.....327
F-2000MWH, F-2000MRH-C.....	P.....328
F-2000MLH,.....	Q.....329
F-2001MLH-C.....	R.....330

These drawings are found in the unit service manual by model.



# A C-101BAH

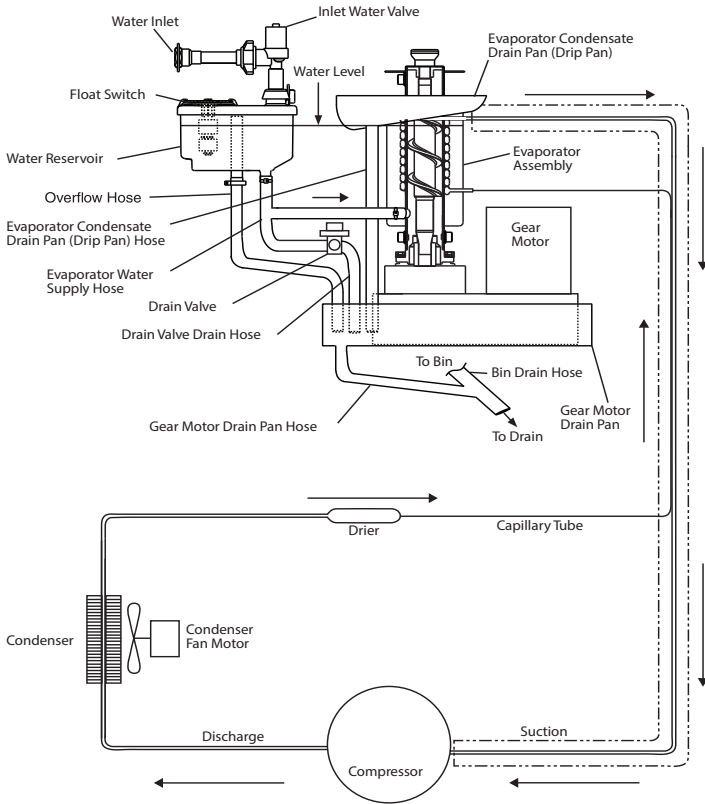

***Drawing is current production. Gear motor drain, drain valve and water circuit piping changes were made from C-0 serial code.***

# B

## DCM-270BAH-OS

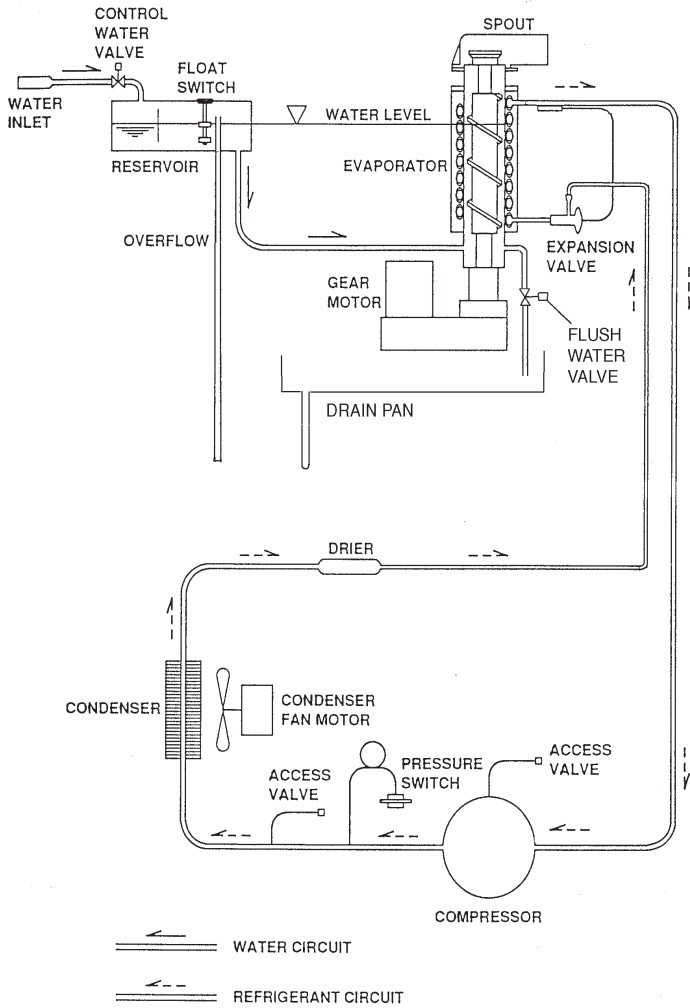

# C

## DCM-500BAH/BWH-OS DCM-750BAH/BWH-OS

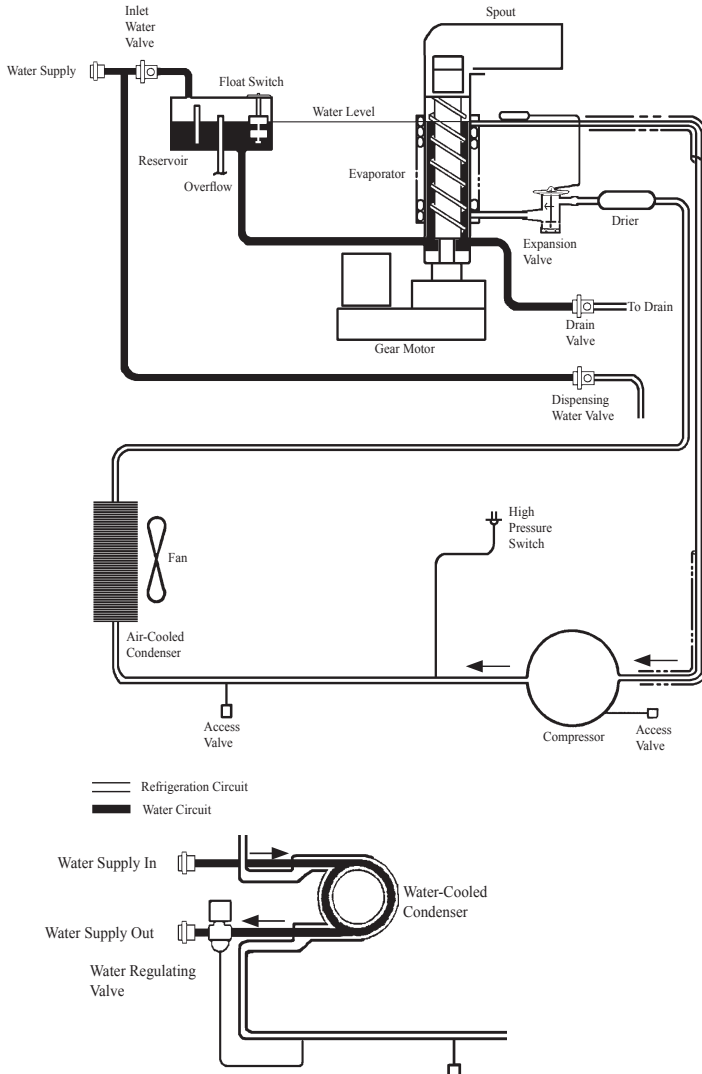

# D

## DT-400BAH-OS

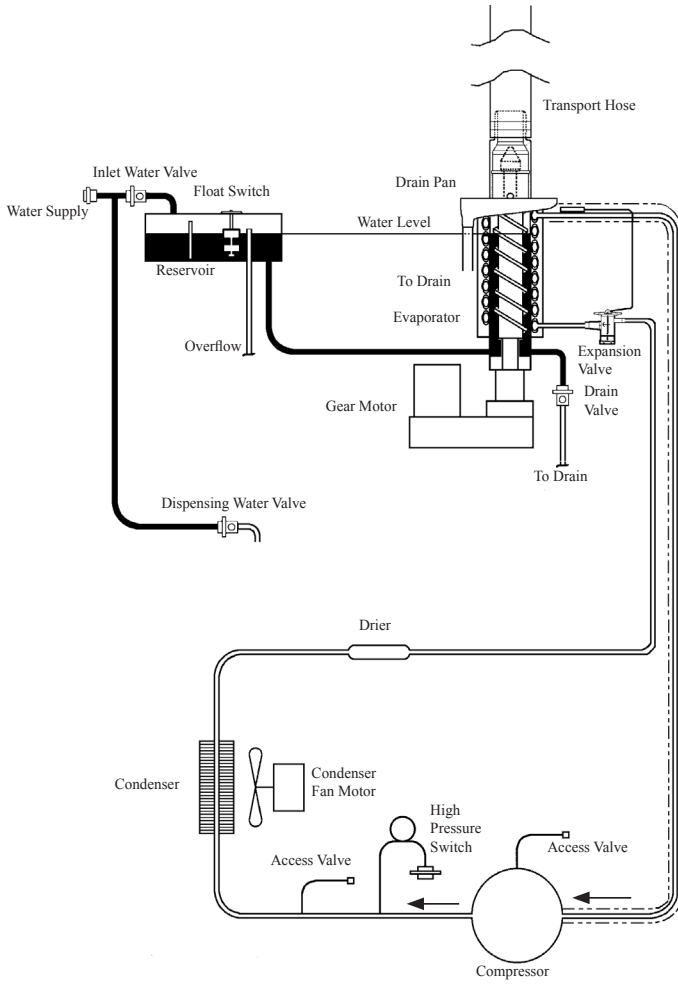

# E

## F-300BAF, F-330BAH(-C)

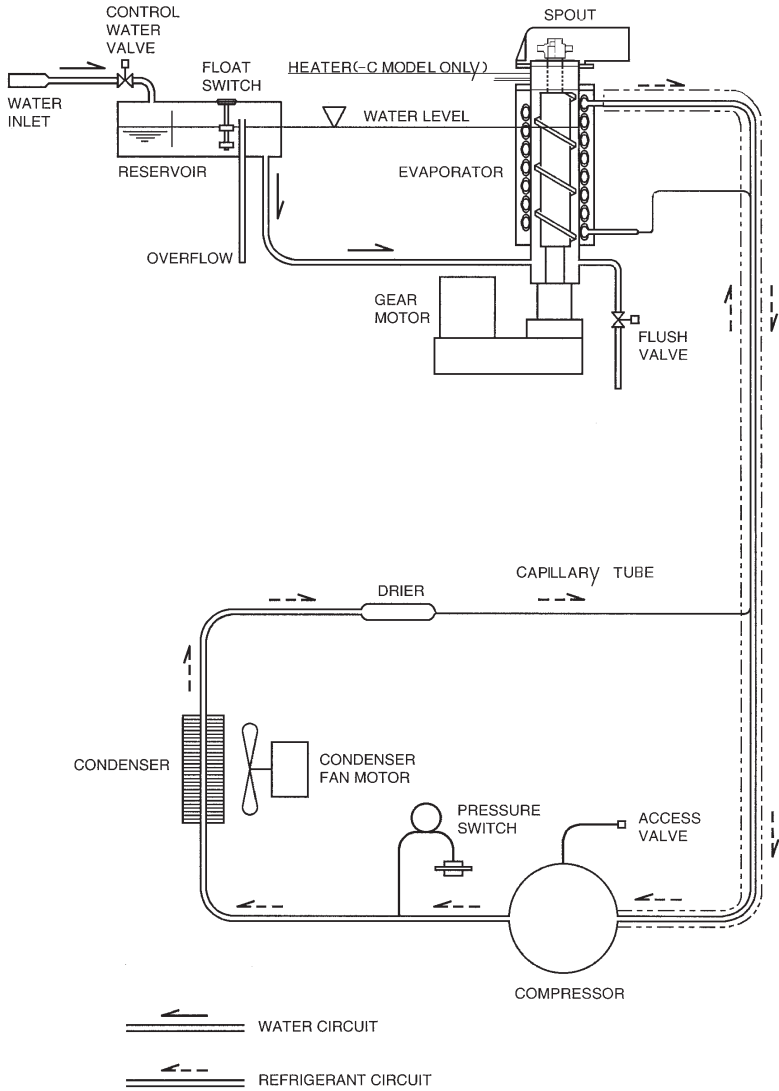

# F F-500BAF

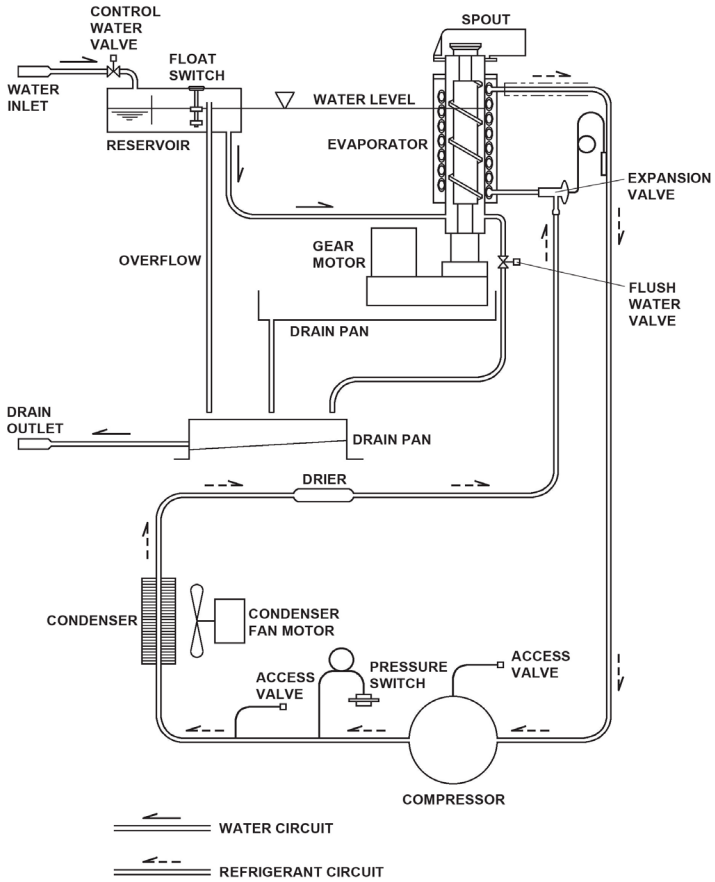

# G

## F-450MAH(-C), F-800MAH/MWH(-C), F-801MAH/MWH(-C), F-1001MAH/MWH(-C), FD-1001MAH/MWH-C, F-1500MAH/MWH(-C)

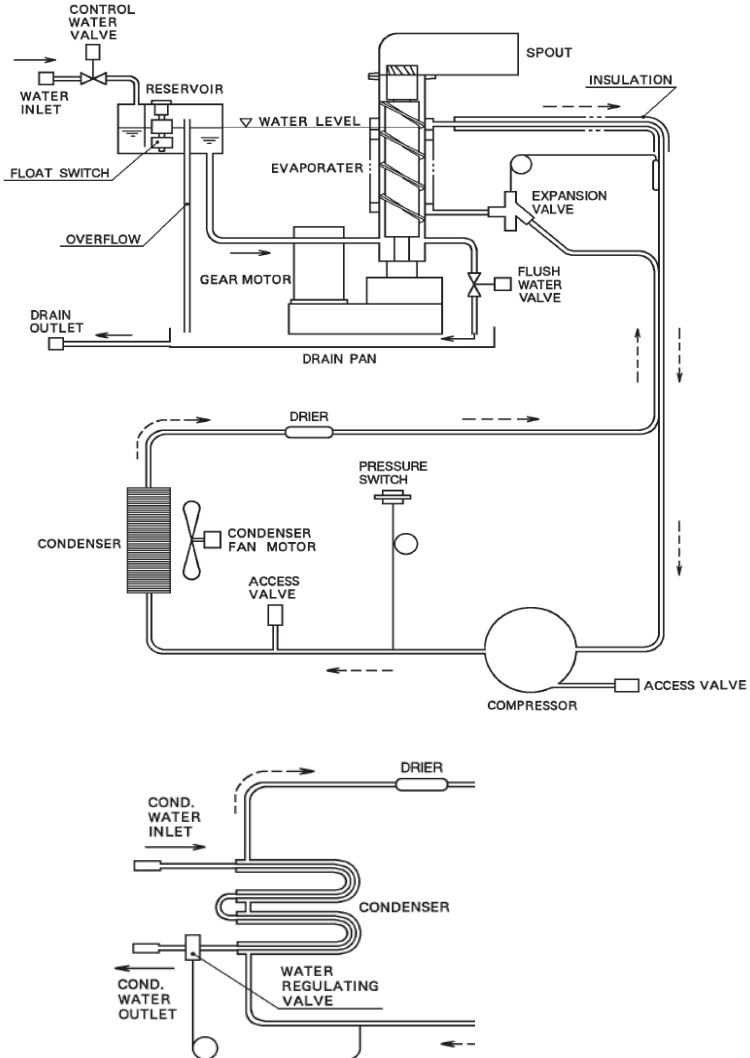

# H

## F-1001MRH(-C) FD-1001MRH-C

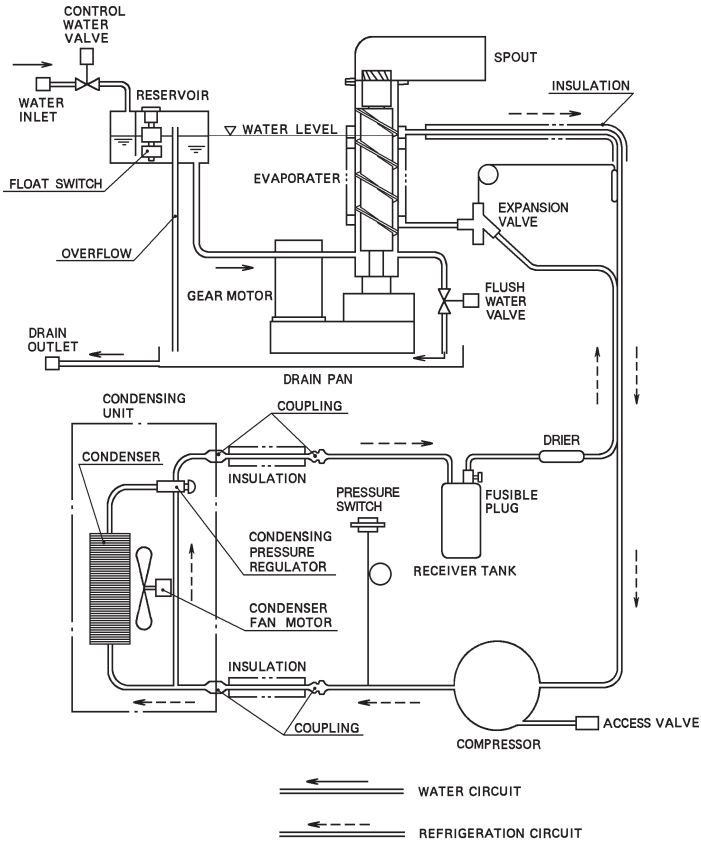



# I F-1001MLH(-C)

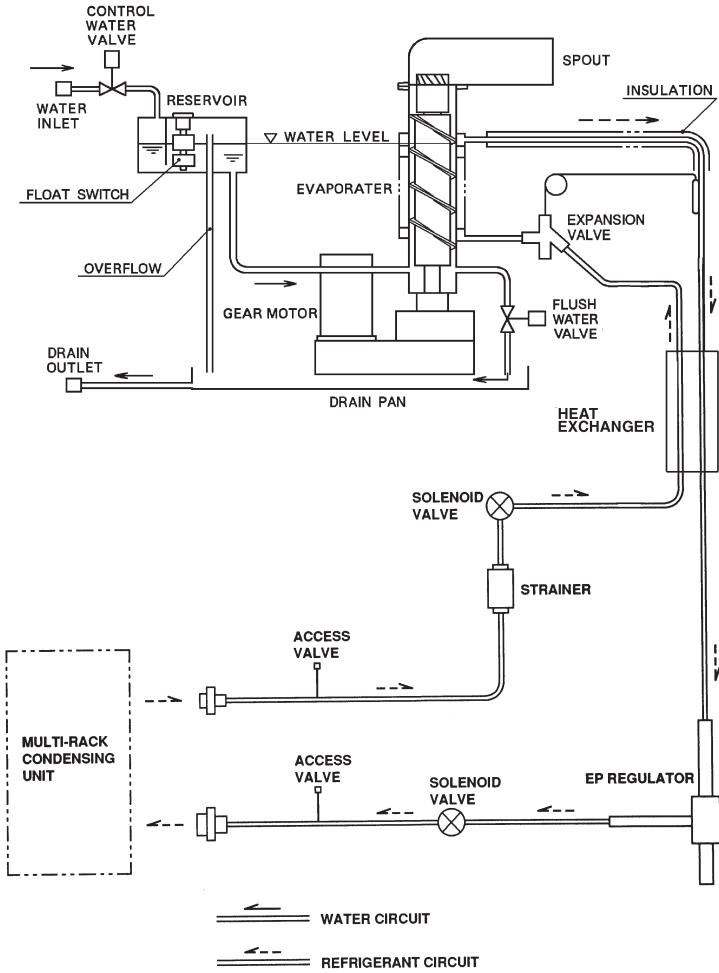

# J FS-1001MLH-C

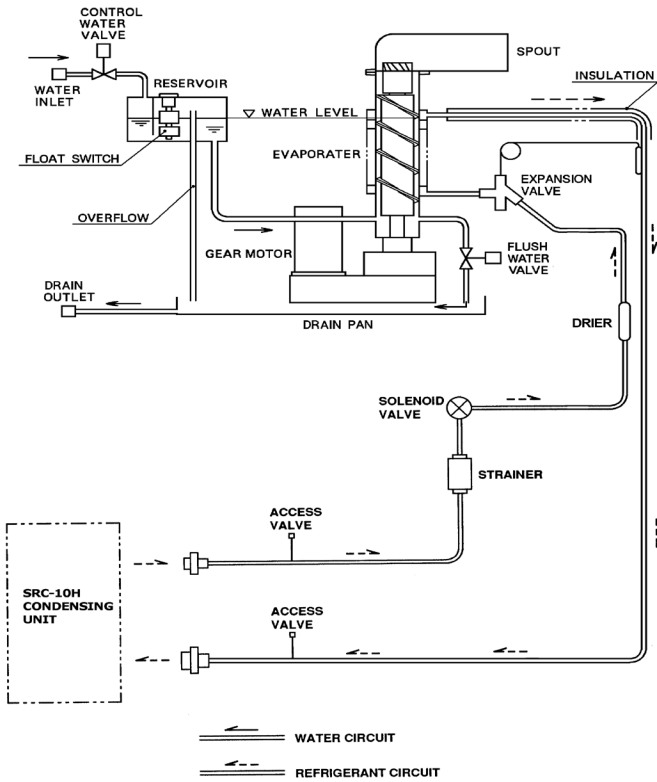

*Water circuit shown for production prior to serial code Q-0 (J).*

## SRC-10H

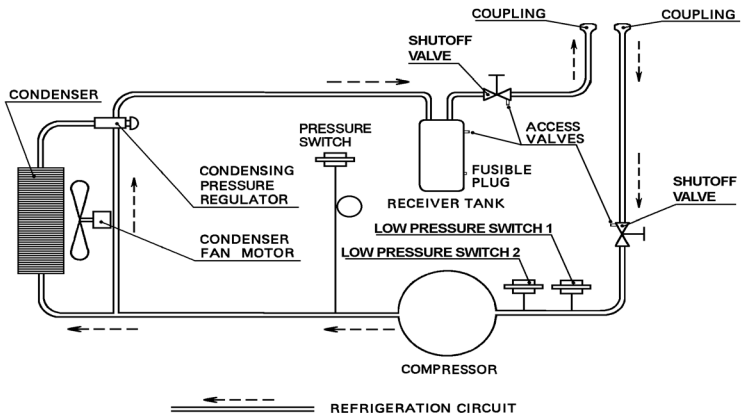

# K F-1500MRH(-C)

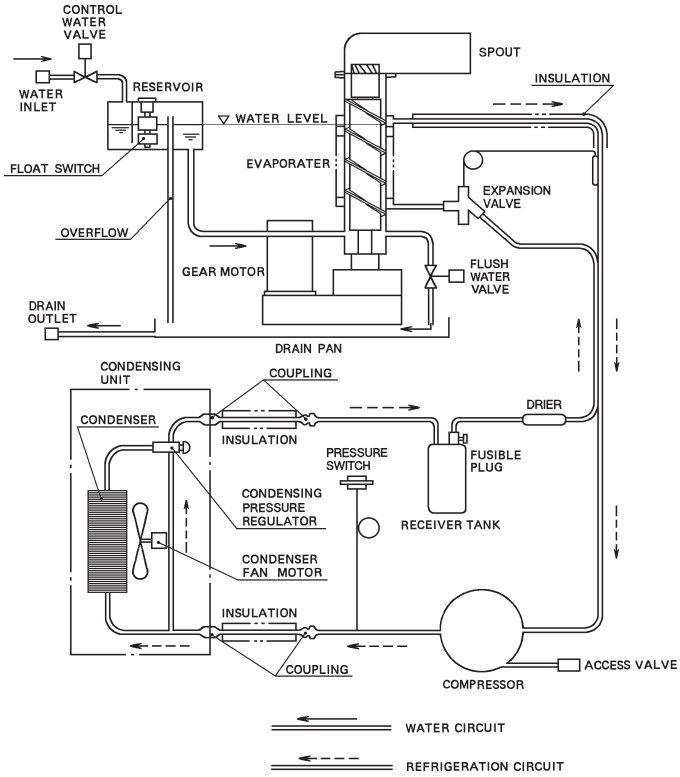

**L**  
**FS-1001MLH-C,**  
**FS-1022MLH(-C), F-1501MLH(-C),**

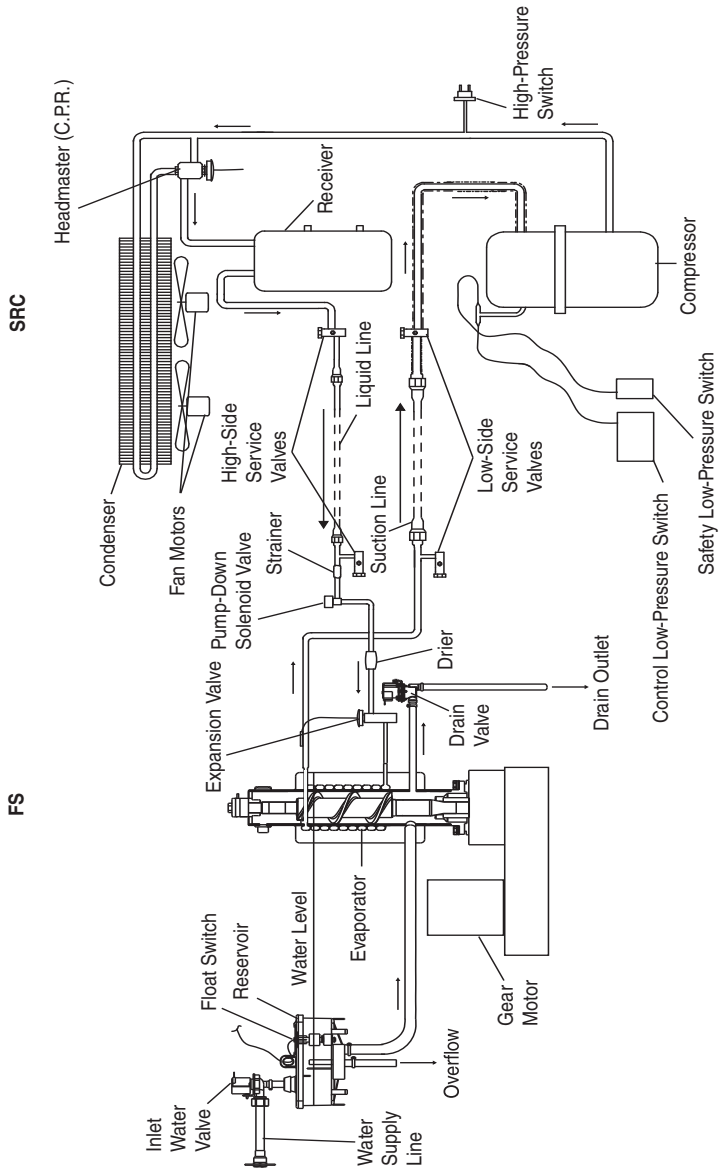

**M**  
**FD-650MAH-C, FD-1001MAH-C,**  
**F-1001MAJ(-C), F-1501MAH(-C),**

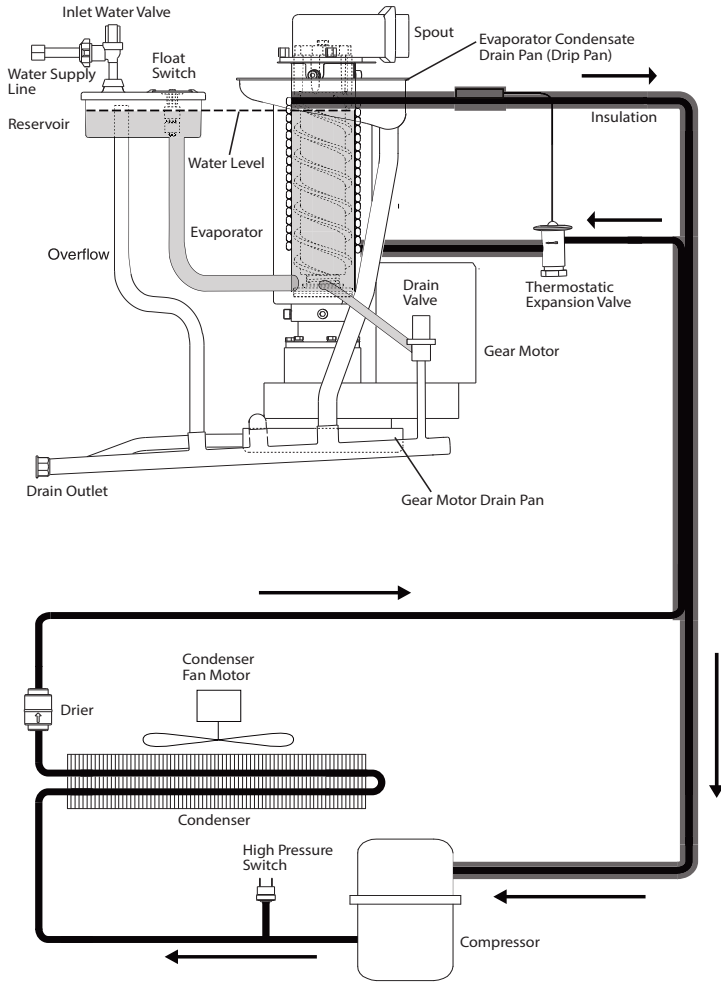

***Current production shows changes made in Water circuit.  
 FD-650MAH and FD-1001MAH all production,  
 F-1001MAJ) all production, F-1501MAH From C-2 (J)***

**N**  
**FD-650MWH-C, FD-1001MWH-C,**  
**F-1001MWJ(-C), F-1501MWH(-C),**  
**F-2000MWH, F-2001MWH**

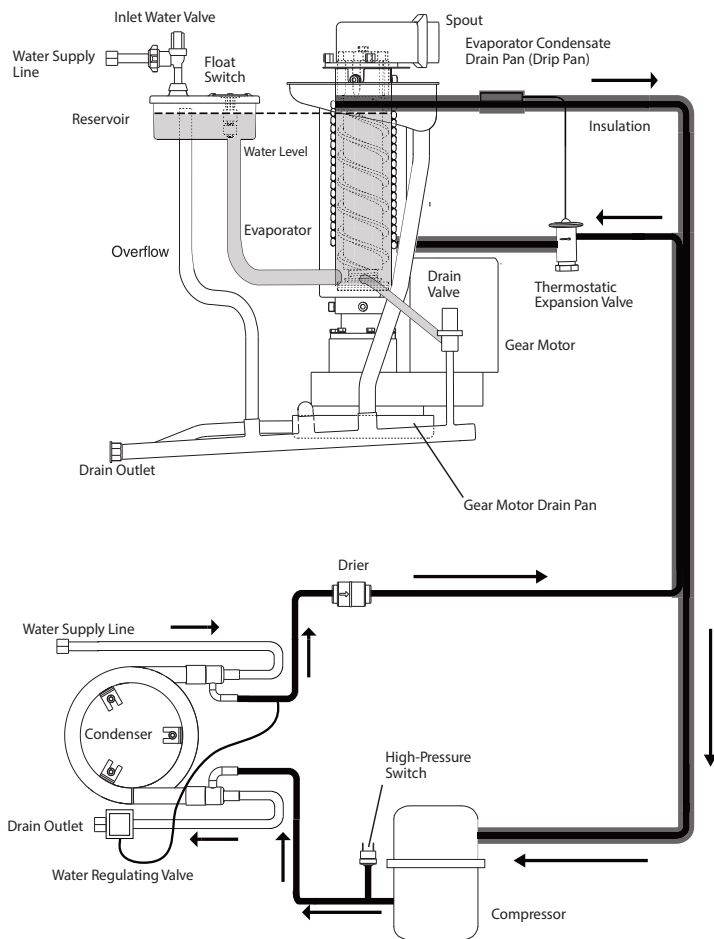

**Current production shows changes made in Water circuit.**  
**FD-650MWH and F-1001MWH all production,**  
**F-1001MWH from Serial C-1 (H), F-1501MWH from C-2 (J),**  
**F-2000MWH from C-2 (L), F-2001MWH all production**

O

**FD-650MRH-C, FD-1001MRH-C,  
F-1001MRH(-C), F-1501MRH(-C),  
F-2000MRH, F-2001MRH(-C)**

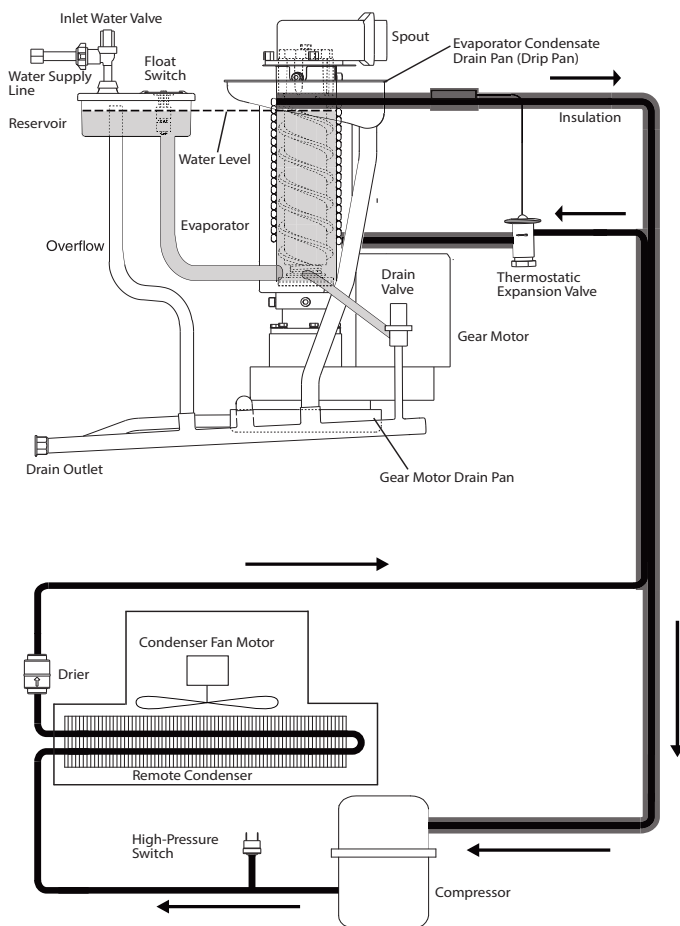

***Current production shows changes made in Water circuit.  
FD-650MRH and F-1001MRH all production,  
F-1001MRH from Serial C-1 (H), F-1501MRH from C-2 (J),  
F-2000MRH from C-0 (D), F-2001MRH all production***

**P**  
**F-2000MWH, F-2000MRH(-C)**

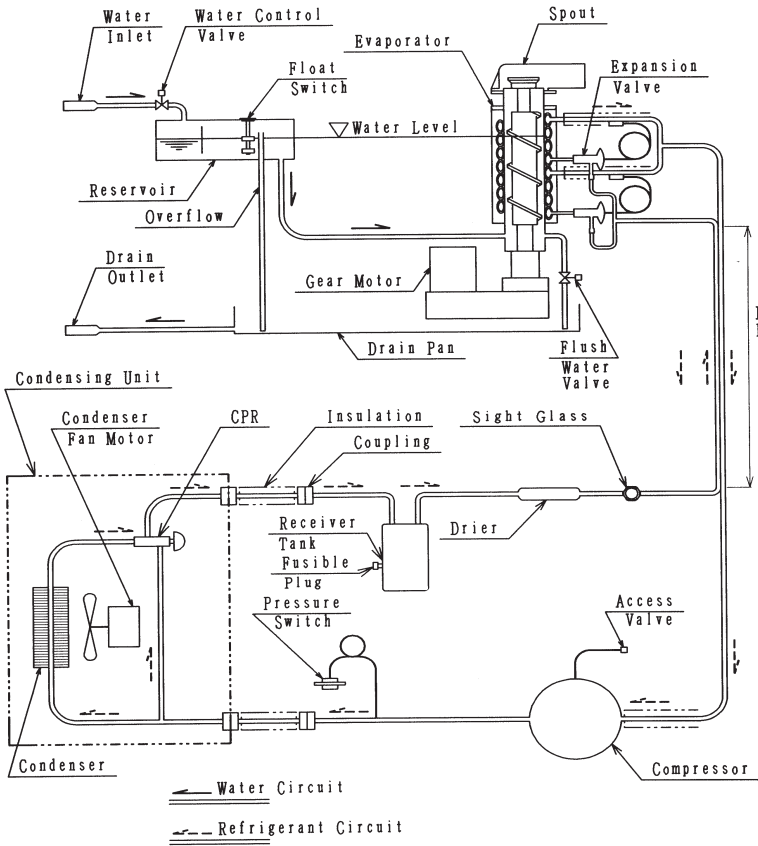

**Water Circuit shown is prior to Serial Code C-0 (D) production.**

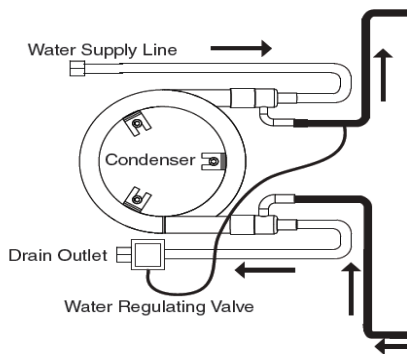



# Q F-2000MLH

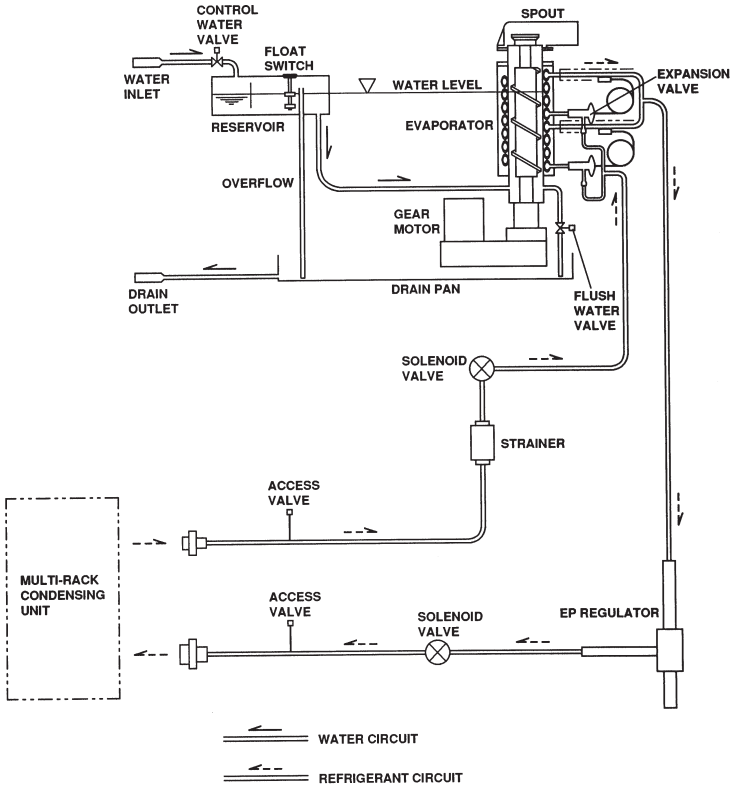

***Water Circuit shown is prior to Serial Code C-2 (L) production.***

# R F-2001MLH(-C)

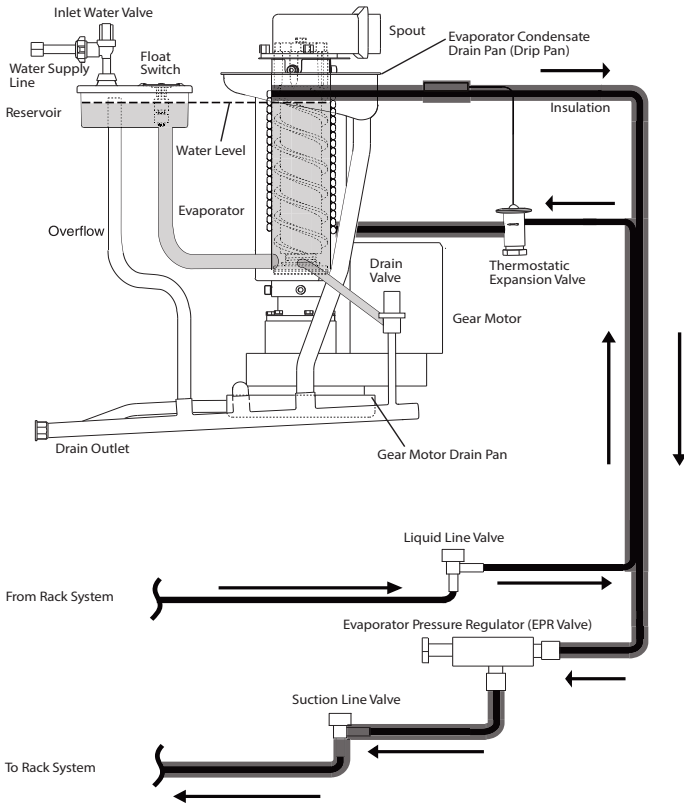

***Current production shows changes made in Water circuit.  
F-2000MLH from C-2 (L), F-2001MRH all production***

**PERFORMANCE DATA**

MODEL: C-101BAH

*Note that this unit uses R-134A Refrigerant*

Total Amperage (Compressor RLA): 4A (3A)

Supply Voltage: 115/60/1

Ambient Temp (F°/C°)		70 / 21	80 / 27	90 / 32	100 / 38
<b>Kg=lbs x.454 Production 24 hours (lbs)</b>	Water Temp F°/C°	Air	Air	Air	Air
	50 / 10	92	81	66	55
	70 / 21	89	71	62	54
	90 / 32	84	66	57	49
<b>Evaporator Outlet temp.</b>	50 / 10	-5	-5	-2	1
	70 / 21	-5	-2	-2	1
	90 / 32	-5	-2	-1	1
<b>Pressure High Side</b>	50 / 10	115	115	115	115
	70 / 21	165	165	165	165
	90 / 32	183	183	183	183
<b>Pressure Suction</b>	50 / 10	12	12	12	12
	70 / 21	17	17	17	17
	90 / 32	19	19	19	19

**PERFORMANCE DATA**

MODEL: DCM-270BAH (-OS)

Total Amperage (Compressor RLA): 8.5A (6A)

Supply Voltage: 115/60/1

Ambient Temp (F°/C°)		70 / 21	80 / 27	90 / 32	100 / 38
<b>kg=lbs x.454</b>	Water Temp	Air	Air	Air	Air
	F°/C°				
<b>Production 24 hours (lbs)</b>	50 / 10	282	248	219	192
	70 / 21	271	238	215	184
	90 / 32	259	228	201	172
<b>Evaporator Outlet temp.</b>	50 / 10	20	20	23	24
	70 / 21	20	23	23	24
	90 / 32	20	23	24	24
<b>Pressure High Side</b>	50 / 10	217	251	285	327
	70 / 21	217	251	285	327
	90 / 32	217	251	285	327
<b>Pressure Suction</b>	50 / 10	37	40	43	46
	70 / 21	37	40	43	46
	90 / 32	37	40	43	46

**PERFORMANCE DATA**

MODEL: DCM-500B\_H(-OS)

Total Amperage (Compressor RLA): BAH 11.5A (7.5A)

BWH 10.5A (7.5A)

Supply Voltage: 115/60/1

Water Consumption for BWH Condenser: 70/50 (21/9) 251 Gal/24hrs

90/70 (32/21) 352Gal/24hrs

Ambient Temp (F°/C°)		70 / 21		80 / 27		90 / 32		100 / 38	
Kg=lbs x.454	Water Temp F°/C°	Air	Water	Air	Water	Air	Water	Air	Water
<b>Production 24 hours (lbs)</b>	50 / 10	535	567	461	529	396	500	340	472
	70 / 21	510	549	438	519	385	495	323	464
	90 / 32	485	539	416	509	358	481	304	428
<b>Evaporator Outlet Temp.</b>	50 / 10	23	19	23	19	26	19	28	19
	70 / 21	23	19	26	19	26	19	28	19
	90 / 32	23	19	26	19	28	19	28	19
<b>Pressure High Side</b>	50 / 10	230	266	264	266	297	266	335	266
	70 / 21	230	267	264	267	297	267	335	267
	90 / 32	230	270	264	270	297	270	335	270
<b>Pressure Suction</b>	50 / 10	33	44	35	44	37	44	43	44
	70 / 21	33	44	35	44	37	44	43	44
	90 / 32	33	47	35	47	37	47	43	47

**PERFORMANCE DATA**

MODEL: DCM-750B\_H (-OS)

Total Amperage (Compressor RLA): BAH 15.7A (10A)

BWH 14.6A (10A)

Supply Voltage: 115/60/1

Water Consumption for BWH-OS Condenser: 70/50 (21/9)

325 Gal/24hrs

90/70 (32/21)

606 Gal/24hrs

Ambient Temp (F°/C°)		70 / 21			80 / 27			90 / 32			100 / 38		
		Air	Water		Air	Water		Air	Water		Air	Water	
<b>Kg=lbs x.454 Production 24 hours (lbs)</b>	Water Temp F°/C°												
	50 / 10	803	744	684	696	662	573	480	630				
	70 / 21	770	719	645	684	654	567	452	620				
90 / 32	726	708	608	673	640	509	423	573					
<b>Evaporator Outlet Temp.</b>	50 / 10	30	19	30	19	19	32	33	19				
	70 / 21	30	19	32	19	19	32	33	19				
	90 / 32	30	19	32	19	19	33	33	19				
<b>Pressure High Side</b>	50 / 10	249	265	280	265	265	310	346	265				
	70 / 21	249	267	280	267	267	310	346	267				
	90 / 32	249	266	280	266	266	310	346	266				
<b>Pressure Suction</b>	50 / 10	44	50	47	50	50	49	52	50				
	70 / 21	44	50	47	50	50	49	52	50				
	90 / 32	44	51	47	51	51	49	52	51				

**PERFORMANCE DATA**

MODEL: DCM-751B\_H (-OS)

Total Amperage (Compressor RLA):

BAH 15.6A (11A)

BWH 14.6A (11A)

Supply Voltage: 115/60/1

Water Consumption for BWH-OS Condenser: 70/50 (21/9)

90/70 (32/21) 609 Gal/24hrs

474 Gal/24hrs

Ambient Temp (F°/C°)	70 / 21		80 / 27		90 / 32		100 / 38		
	Water Temp F°/C°	Air	Water	Air	Water	Air	Water	Air	
<b>Kg= lbs x .454 Production 24 hours (lbs)</b>	50 / 10	801	800	695	738	612	681	539	629
	70 / 21	757	779	666	719	583	685	517	612
	90 / 32	725	758	639	700	562	646	490	563
<b>Evaporator Outlet Temp.</b>	50 / 10	14	12	14	12	18	12	20	13
	70 / 21	14	12	18	12	18	12	20	13
	90 / 32	14	12	18	12	20	13	20	13
<b>Pressure High Side</b>	50 / 10	217	258	253	259	289	260	327	257
	70 / 21	217	258	253	259	289	260	327	257
	90 / 32	217	258	253	259	289	260	327	257
<b>Pressure Suction</b>	50 / 10	32	32	34	33	36	33	38	35
	70 / 21	32	32	34	33	36	33	38	35
	90 / 32	32	32	34	33	36	33	38	35

**PERFORMANCE DATA**

MODEL: F-300BAF

Supply Voltage: 115/60/1

Total Amperage (Compressor RLA): Air: 9A (6.5A)

Ambient Temp (F°/C°)	70 / 21	80 / 27	90 / 32	100 / 38
Water Temp F°/C°	Air	Air	Air	Air
<b>Kg=lbs x.454 Production 24 hours (lbs)</b>	303 290 278	267 256 278	236 232 218	209 201 188
<b>Evaporator Outlet Temp.</b>	19 19 19	19 22 22	22 22 26	26 26 26
<b>Pressure High Side</b>	250 250 250	280 280 280	311 311 311	351 351 351
<b>Pressure Suction</b>	35 35 35	37 37 37	39 39 39	43 43 43



**PERFORMANCE DATA**

MODEL: F-330BAH

Supply Voltage: 115/60/1

Total Amperage (Compressor RLA):

Air: 6.7A (4.5A)

-C: 7.4A (4.5A)

Ambient Temp (F°/C°)	70 / 21		80 / 27		90 / 32		100 / 38	
	Air	-C	Air	-C	Air	-C	Air	-C
<b>Kg=lbs x.454 Production 24 hours (lbs)</b>	Water Temp F°/C°							
	50 / 10	330	320	290	275	255	240	210
	70 / 21	315	300	280	265	250	230	200
90 / 32	300	290	270	250	235	220	205	190
<b>Evaporator Outlet Temp.</b>	50 / 10	16		16		13		12
	70 / 21	16		13		13		12
	90 / 32	16		13		12		12
<b>Pressure High Side</b>	50 / 10	320		299		279		212
	70 / 21	320		299		279		212
	90 / 32	320		299		279		212
<b>Pressure Suction</b>	50 / 10	36		39		42		45
	70 / 21	36		39		42		45
	90 / 32	36		39		42		45

**PERFORMANCE DATA**

MODEL: DT-400BAH-OS

Supply Voltage: 115/60/1

Total Amperage (Compressor RLA): Air: 11.5A (8A)

Ambient Temp (F°/C°)		70 / 21	80 / 27	90 / 32	100 / 38
<b>Kg=lbs x.454 Production 24 hours (lbs)</b>	Water Temp F°/C°	Air	Air	Air	Air
	50 / 10	409	354	308	268
	70 / 21	388	338	296	256
	90 / 32	370	322	281	242
<b>Evaporator Outlet Temp.</b>	50 / 10	15	16	17	19
	70 / 21	16	16	17	19
	90 / 32	16	17	18	20
<b>Pressure High Side</b>	50 / 10	236	236	236	236
	70 / 21	303	303	303	303
	90 / 32	342	342	342	342
<b>Pressure Suction</b>	50 / 10	30	30	30	30
	70 / 21	35	35	35	35
	90 / 32	38	38	38	38

**PERFORMANCE DATA**

MODEL: F-450MAH (-C) Supply Voltage: 115/60/1

Total Amperage (Compressor RLA):

Air: 11A (7.5A)

	70 / 21		80 / 27		90 / 32		100 / 38		
	Air	-C	Air	-C	Air	-C	Air	-C	
<b>Ambient Temp (F°/C°)</b>									
<b>Water Temp F°/C°</b>									
<b>Kg=lbs x.454 Production 24 hours (lbs)</b>	50 / 10	484	403	424	380	372	335	327	300
	70 / 21	462	410	406	365	362	325	313	290
	90 / 32	442	395	389	350	341	310	294	270
<b>Evaporator Outlet Temp.</b>	50 / 10	3		3		7		9	
	70 / 21	3		7		7		9	
	90 / 32	3		7		9		9	
<b>Pressure High Side</b>	50 / 10	225		256		286		324	
	70 / 21	225		256		286		324	
	90 / 32	225		256		286		324	
<b>Pressure Suction</b>	50 / 10	28		31		33		37	
	70 / 21	28		31		33		37	
	90 / 32	28		31		33		37	

**PERFORMANCE DATA**

MODEL: F-500BAF(-C)

Supply Voltage: 115/60/1

Total Amperage (Compressor RLA):

Air: 10.4A (7.5A)

	70 / 21		80 / 27		90 / 32		100 / 38	
	Air	-C	Air	-C	Air	-C	Air	-C
<b>Ambient Temp (F°/C°)</b>								
<b>Water Temp F°/C°</b>								
<b>Kg=lbs x.454</b>								
<b>Production 24 hours (lbs)</b>	478	431	419	381	366	336	320	295
	458	415	400	365	359	333	306	283
	438	398	383	350	383	308	287	263
<b>Evaporator Outlet Temp.</b>	8	9	8	9	12	12	15	15
	8	9	12	12	11	12	15	15
	8	9	12	12	15	15	15	15
<b>Pressure High Side</b>	221	225	253	258	285	292	327	332
	221	225	253	258	285	292	327	332
	221	225	253	258	285	292	327	332
<b>Pressure Suction</b>	26	27	28	30	31	32	34	35
	26	27	28	30	31	32	34	35
	26	27	28	30	31	32	34	35

**PERFORMANCE DATA**

MODEL: FD-650M\_H-C

Supply Voltage: 115/60/1

Total Amperage (Compressor RLA):

Air: 11.3A (7.9A)    Water:7.9A(5.5A)    Remote: 10.9A (5.5A)

Water Consumption for MWH Condenser:

70/50 (21/10) 303 Gal/24hrs      80 / 27      90 / 32      90/70 (32/21) 480 Gal/24hrs

	70 / 21			80 / 27			90 / 32			90/70 (32/21) 480 Gal/24hrs		
	Air	Water	Remote	Air	Water	Remote	Air	Water	Remote	Air	Water	Remote
<b>Kg=lbs x.454</b>	Water Temp											
<b>Production</b>	F°/C°											
<b>24 hours</b>	650	615	590	576	569	531	490	525	477	423	484	428
<b>(lbs)</b>	627	601	571	523	554	513	474	532	476	418	471	413
	593	595	551	490	539	495	439	497	444	380	431	382
<b>Evaporator</b>	19	8	10	19	11	13	23	9	12	25	9	11
<b>Outlet Temp.</b>	19	9	11	23	8	10	23	10	12	25	9	11
	19	10	12	23	9	12	25	8	10	25	11	13
<b>Pressure</b>	250	272	204	282	272	204	310	272	204	337	272	204
<b>High Side</b>	263	275	245	291	275	245	319	275	245	348	275	245
	273	284	279	300	284	279	327	284	279	358	284	279
<b>Pressure</b>	41	41	44	43	41	44	45	41	44	47	41	44
<b>Suction</b>	41	43	46	43	43	46	45	43	46	47	43	46
	41	45	47	43	45	47	46	45	47	47	45	47

**PERFORMANCE DATA**

MODEL: F-800M\_H  
 Total Amperage (Compressor RLA): Air: 11.7A (9.2A)      Supply Voltage: 115/60/1  
 Water consumption for MWH Cond: 70/50 (21/10) 405 Gal/24hrs      90/70 (32/21) 614 Gal/24hrs      Water: 10.8A (9.2A)

	70 / 21			80 / 27			90 / 32			100 / 38		
	Air	Water	Water Temp F°/C°	Air	Water	Water	Air	Water	Water	Air	Water	Water
<b>Kg=lbs x.454 Production 24 hours (lbs)</b>	760	720	50 / 10	665	670	640	585	640	605	510	605	605
	730	695	70 / 21	640	660	625	575	625	595	490	595	595
	700	680	90 / 32	610	650	620	535	620	555	455	555	555
<b>Evaporator Outlet Temp.</b>	16	21	50 / 10	18	22	21	21	21	23	22	23	23
	17	22	70 / 21	18	22	22	19	22	23	23	23	23
	17	21	90 / 32	19	22	23	21	23	22	23	22	22
<b>Pressure High Side</b>	221	265	50 / 10	254	267	266	286	266	267	325	267	267
	221	267	70 / 21	254	266	254	286	266	269	325	269	269
	221	266	90 / 32	254	265	265	286	265	268	325	268	268
<b>Pressure Suction</b>	35	37	50 / 10	38	38	38	41	38	39	45	39	39
	35	37	70 / 21	38	37	38	41	38	39	45	39	39
	35	37	90 / 32	38	38	38	41	38	39	45	39	39

**PERFORMANCE DATA**

MODEL: F-800M\_H-C

Supply Voltage: 115/60/1

Total Amperage (Compressor RLA):

Air: 11.7A (9.2A)

Water: 10.8A (9.2A)

Water consumption for MWH-C Cond: 70/50 (21/10) 398 Gal/24hrs 90/70 (32/21) 624 Gal/24hrs

	70 / 21			80 / 27			90 / 32			100 / 38		
	Air	Water	Water Temp F°/C°	Air	Water	Water	Air	Water	Water	Air	Water	Water
<b>Kg=lbs x.454 Production 24 hours (lbs)</b>	760	670	50 / 10	665	625	Water	585	590	Water	510	560	Water
	730	650	70 / 21	640	615		575	590		490	550	
	700	640	90 / 32	610	605		435	570		455	505	
<b>Evaporator Outlet Temp.</b>	16	21	50 / 10	18	22	Water	21	21	Water	22	23	Water
	17	22	70 / 21	18	22		19	23		23	23	
	17	21	90 / 32	19	22		21	22		23	23	
<b>Pressure High Side</b>	221	265	50 / 10	254	267	Water	286	266	Water	325	267	Water
	221	267	70 / 21	254	266		286	266		325	269	
	221	266	90 / 32	254	265		286	265		325	268	
<b>Pressure Suction</b>	35	37	50 / 10	38	38	Water	41	38	Water	45	39	Water
	35	37	70 / 21	38	38		41	38		45	39	
	35	37	90 / 32	38	38		41	38		45	39	

**PERFORMANCE DATA**

MODEL: F-801M\_H

Supply Voltage: 115/60/1

Total Amperage (Compressor RLA):

Air: 13.3A (7.5A)

Water: 11.5A (7.5A)

Water Consumption for MWH Cond: 70/50 (21/10) 306 Gal/24hrs

90/70 (32/21) 433 Gal/24hrs

	70 / 21		80 / 27		90 / 32		100 / 38	
	Air	Water	Air	Water	Air	Water	Air	Water
<b>Kg=lbs x.454 Production 24 hours (lbs)</b>	Water Temp F°/C°							
	50 / 10	720	711	661	613	616	528	573
	70 / 21	693	677	646	599	605	502	560
	90 / 32	677	644	630	555	587	471	520
<b>Evaporator Outlet Temp.</b>	50 / 10	17	16	19	17	20	19	20
	70 / 21	16	17	19	17	20	19	20
	90 / 32	16	18	17	20	20	20	21
<b>Pressure High Side</b>	50 / 10	204	204	265	204	265	204	265
	70 / 21	266	265	266	265	266	266	265
	90 / 32	302	266	302	266	302	302	266
<b>Pressure Suction</b>	50 / 10	38	42	42	38	42	38	42
	70 / 21	42	43	42	42	43	42	43
	90 / 32	46	44	46	44	46	46	44



**PERFORMANCE DATA**

MODEL: F-801M\_H-C

Supply Voltage: 115/60/1

Total Amperage (Compressor RLA):

Air: 13.3A (7.5A)

Water: 11.53A (7.5A)

Water consumption for MWH-C Cond: 70/50 (21/10) F-800/801= 318/199 Gal/24hrs 90/70 (32/21) F-800/801 = 553/302 Gal/24hrs

Ambient Temp (F°/C°)		70 / 21			80 / 27			90 / 32			100 / 38		
		Air	Water		Air	Water		Air	Water		Air	Water	
<b>Kg=lbs x .454 Production 24 hours (lbs)</b>	50 / 10	752	645		650	596		548	563		463	531	
	70 / 21	728	620		614	585		552	550		437	521	
	90 / 32	688	608		580	574		490	541		405	485	
<b>Evaporator Outlet Temp.</b>	50 / 10	14	20		14	21		14	21		16	21	
	70 / 21	14	20		14	21		14	21		18	21	
	90 / 32	14	21		14	21		16	21		18	22	
<b>Pressure High Side</b>	50 / 10	200	263		226	263		249	263		273	263	
	70 / 21	212	263		233	263		265	263		282	263	
	90 / 32	219	264		241	264		265	264		296	264	
<b>Pressure Suction</b>	50 / 10	38	46		42	46		43	46		43	46	
	70 / 21	41	46		42	46		43	46		44	46	
	90 / 32	42	47		42	47		43	47		48	47	

**PERFORMANCE DATA**

MODEL: F-1001M\_H      Supply Voltage: 208-230/60/1 (3 wire w/neutral for 115V)  
 Total Amperage (Compressor RLA):      Air: 7.9A (4.2A)      Water: 7A (4.2A)      Remote: 10A (4.2A)

Water Consumption for MWH Condenser:		70 / 21			80 / 27			90 / 32			90 / 70 (32/21) 480 Gal/24hrs		
		Air	Water	Remote	Air	Water	Remote	Air	Water	Remote	Air	Water	Remote
<b>Kg= lbs x .454 Production 24 hours (lbs)</b>	Water Temp F°/C°												
	50 / 10	970	890	930	855	820	835	755	770	750	665	720	675
	70 / 21	930	855	895	820	805	805	740	755	745	635	705	650
<b>Evaporator Outlet Temp.</b>	90 / 32	890	840	865	785	785	780	695	735	700	595	655	605
	50 / 10	19	23	23	19	23	25	23	23	26	25	23	28
	70 / 21	19	23	24	23	23	26	23	23	27	25	23	28
<b>Pressure High Side</b>	90 / 32	19	25	25	23	25	26	25	25	28	25	25	28
	50 / 10	213	263	221	244	263	239	274	263	256	315	263	295
	70 / 21	213	266	221	244	266	239	274	266	256	315	266	295
<b>Pressure Suction</b>	90 / 32	213	269	221	244	269	239	274	269	256	315	269	295
	50 / 9	32	33	33	35	33	35	38	33	36	41	33	39
	70 / 21	32	34	33	35	34	35	38	34	36	41	34	39
	90 / 32	32	35	33	35	35	35	38	35	36	41	35	39

**PERFORMANCE DATA**

MODEL: F-1001M\_H-C

Supply Voltage: 208-230/60/1 (3 wire w/neutral for 115V)

Total Amperage (Compressor RLA): Air: 7.9A (4.2A) Water: 7A (4.2A) Remote: 10A (4.2A)

Water Consumption for MWH-C Condenser: 70/50 (21/10) 303 Gal/24hrs 90/70 (32/21) 492 Gal/24hrs

Kg=lbs x.454 Production 24 hours (lbs)	70 / 21			80 / 27			90 / 32			100 / 38				
	Ambient Temp (F°/C°)	Water Temp F°/C°	Air	Water	Remote	Air	Water	Remote	Air	Water	Remote	Air	Water	Remote
	50 / 10	790	910	790	840	800	735	765	730	695	700	632	660	640
	70 / 21	760	860	720	810	770	720	745	680	685	695	610	645	620
	90 / 32	750	830	740	790	740	710	720	660	670	660	575	600	575
<b>Evaporator Outlet Temp.</b>	50 / 10	23	18	23	23	23	23	25	23	23	26	27	23	28
	70 / 21	23	18	23	24	23	23	26	23	23	27	27	23	28
	90 / 32	18	18	25	25	23	25	26	27	25	28	27	25	28
<b>Pressure High Side</b>	50 / 10	209	209	263	220	243	263	238	277	263	256	317	263	295
	70 / 21	209	209	266	220	243	266	238	277	266	256	317	266	295
	90 / 32	209	209	269	220	243	269	238	277	269	256	317	269	295
<b>Pressure Suction</b>	50 / 10	32	32	33	34	35	33	36	38	33	37	41	33	40
	70 / 21	32	32	34	34	35	34	36	38	34	37	41	34	40
	90 / 32	32	32	35	34	35	35	36	38	35	37	41	35	40

**PERFORMANCE DATA**

MODEL: F-1001M\_J

\*\* Supply Voltage: 115/60/1

Total Amperage (Compressor RLA):

Air: 15.2A (11.2A)    Water: 14.2A (12A)    Remote: 15.9 (11.2A)

Water Consumption for MWH-C Condenser:

70/50 (21/10) 303 Gal/24hrs    90/70 (32/21) 492 Gal/24hrs

C°	70 / 21			80 / 27			90 / 32			100 / 38		
	Air	Water	Remote	Air	Water	Remote	Air	Water	Remote	Air	Water	Remote
<b>kg=lbs x.454 Production 24 hours (lbs)</b>												
Water Temp F°/C°												
50 / 10	970	890	930	871	828	834	764	763	741	671	702	659
70 / 21	951	875	902	834	806	802	748	750	713	642	683	633
90 / 32	910	852	867	798	784	771	701	722	685	575	655	605
<b>Evaporator Outlet Temp.</b>												
50 / 10	19	23	23	20	23	25	21	23	26	23	24	28
70 / 21	20	23	24	20	23	25	21	23	27	24	24	28
90 / 32	20	23	24	21	23	26	22	23	27	25	25	28
<b>Pressure High Side</b>												
50 / 10	213	263	221	239	264	236	265	266	251	295	268	276
70 / 21	222	263	226	248	265	241	274	266	256	305	268	285
90 / 32	230	264	231	257	265	246	257	267	266	315	269	295
<b>Pressure Suction</b>												
50 / 10	32	33	33	35	33	34	37	34	36	40	35	38
70 / 21	33	33	33	35	34	35	38	34	36	40	35	38
90 / 32	34	33	34	36	34	35	39	34	37	41	35	39

**PERFORMANCE DATA**

MODEL: F-1001M\_J-C

\*\* Supply Voltage: 115/60/1

Total Amperage (Compressor RLA): Air: 15.2A (11.2A) Water: 14.2A (12A) Remote: 15.9 (11.2A)

Water Consumption for MWH-C Condenser: 70/50 (21/10) 303 Gal/24hrs 90/70 (32/21) 492 Gal/24hrs

Kg=lbs x.454 Production 24 hours (lbs)	70 / 21			80 / 27			90 / 32			100 / 38		
	Air	Water	Remote	Air	Water	Remote	Air	Water	Remote	Air	Water	Remote
Water Temp F°/C°												
50 / 10	910	790	840	797	700	771	700	700	696	616	651	629
70 / 21	869	788	825	764	703	745	656	703	683	590	636	608
90 / 32	832	770	797	731	717	720	643	667	650	575	600	575
Evaporator Outlet Temp.	18	23	23	20	23	25	22	23	26	25	24	28
	18	23	24	21	23	25	23	23	27	26	24	28
	19	23	24	21	23	26	24	23	27	27	25	28
Pressure High Side	213	263	220	264	263	235	265	266	276	295	268	276
	222	263	225	265	266	241	274	266	256	305	268	285
	230	264	230	265	269	246	257	267	266	315	269	295
Pressure Suction	32	33	34	35	33	35	37	34	37	40	35	39
	33	33	34	35	34	36	38	34	37	40	35	39
	34	33	35	36	34	36	39	34	38	41	35	40

## PERFORMANCE DATA

MODEL: F-1001MLH (-C)

Supply Voltage: 115/60/1

Total Amperage : 3.03A This unit designed for connected to a rack system using R-404A. The data below is calculated.

Ambient Temp (F°/C°)	70 / 21		80 / 27		90 / 32		100 / 38	
	Water Temp F°/C°	Remote	-C	Remote	-C	Remote	-C	Remote
<b>Kg=lbs x.454</b>								
<b>Production</b>	50 / 10	1150	1020	980	885	900	805	830
<b>24 hours</b>	70 / 21	1035	945	950	860	885	795	805
<b>(lbs)</b>	90 / 32	1005	915	925	835	805	760	690
<b>Evaporator</b>	50 / 10		21		21		21	
<b>Outlet</b>	70 / 21		21		21		21	
<b>Temp.</b>	90 / 32		21		21		23	
<b>Pressure</b>	50 / 10		106		125		143	
<b>High Side</b>	70 / 21		106		125		143	
	90 / 32		106		125		143	
<b>Pressure</b>	50 / 10		26		30		33	
<b>Suction</b>	70 / 21		26		30		33	
	90 / 32		26		30		33	

**Note:** The data provided is calculated by using a refrigeration capacity of 5700BTU/h with a high side pressure of 213PSIG and suction pressure of 31.2 PSIG. The actual production and system operating pressures will vary depending on the specific R-404A rack system setup. Factory setting for the Evaporator Pressure Regulating Valve (EPR) is 32 PSIG for an evaporator temperature no less than 0 °F (-17.7 °C).

**PERFORMANCE DATA**

MODEL: FS-1001MLH-C or FS-1022MLH-C w/SRC-10H      Supply Voltage: 115/60/1

Total Amperage (Compressor RLA): Low Side MLH: 3A    SRC-10H condenser: 13.1A (9.6A)

Ambient Temp (F°/C°)		70 / 21	80 / 27	90 / 32	100 / 38
<b>Kg=lbs x.454 Production 24 hours (lbs)</b>	Water Temp F°/C°	Low Side	Low Side	Low Side	Low Side
	50 / 10	832	765	712	663
	70 / 21	803	747	703	647
	90 / 32	784	729	679	600
<b>Evaporator Outlet Temp.</b>	50 / 10	14	14	16	18
	70 / 21	14	16	16	18
	90 / 32	14	16	18	18
<b>Pressure High Side</b>	50 / 10	224	233	242	279
	70 / 21	224	233	242	279
	90 / 32	224	233	242	279
<b>Pressure Suction</b>	50 / 10	29	30	31	33
	70 / 21	29	30	31	33
	90 / 32	29	30	31	33

**PERFORMANCE DATA**

MODEL: F-1500M\_H

Supply Voltage: 208-230/60/1 (3 wire w/neutral for 115V)

Total Amperage (Compressor RLA):

Air: 16.25A (9.3A)    Water: 15.9A (9.3A)    Remote: 18.9A (9.3A)

Water Consumption for MWH Condenser:

70/50 (21/10) 435 Gal/24hrs    80/70 (32/21) 675 Gal/24hrs    90/70 (32/21) 675 Gal/24hrs

Kg=lbs x.454	70 / 21			80 / 27			90 / 32			100 / 38		
	Air	Water	Remote	Air	Water	Remote	Air	Water	Remote	Air	Water	Remote
<b>Production 24 hours (lbs)</b>	50 / 10	1435	1585	1382	1335	1439	1206	1260	1309	1051	1185	1192
	70 / 21	1514	1390	1321	1310	1394	1170	1245	1300	1005	1160	1155
	90 / 32	1447	1360	1484	1285	1351	1100	1210	1230	945	1075	1070
<b>Evaporator Outlet Temp. (F°)</b>	50 / 10	16	25	19	25	19	18	25	21	19	25	23
	70 / 21	16	25	19	25	21	18	25	21	19	25	23
	90 / 32	16	25	19	25	21	19	25	23	19	25	23
<b>Pressure High Side</b>	50 / 10	210	262	215	262	228	270	262	240	310	262	275
	70 / 21	210	263	215	263	228	270	263	240	310	263	275
	90 / 32	210	265	215	265	228	270	265	240	310	265	275
<b>Pressure Suction</b>	50 / 10	35	40	36	40	38	40	40	40	42	40	42
	70 / 21	35	40	36	40	38	40	40	40	42	40	42
	90 / 32	35	41	36	41	38	40	41	40	42	41	42



**PERFORMANCE DATA**

MODEL: F-1500M\_H-C

Supply Voltage: 208-230/60/1 (3 wire w/neutral for 115V)

Total Amperage (Compressor RLA):

Air: 16.25A (9.3A)    Water: 15.9A (9.3A)    Remote: 18.9A (9.3A)

Water Consumption for MWH-C Condenser: 70/50 (21/10) 435 Gal/24hrs

90/70 (32/21) 630 Gal/24hrs

Kg=lbs x.454	70 / 21			80 / 27			90 / 32			100 / 38		
	Water Temp F°/C°			Air	Water	Remote	Air	Water	Remote	Air	Water	Remote
<b>Production 24 hours (lbs)</b>	50 / 10	1300	1125	1335	1145	1050	1223	1011	1010	1123	980	1031
	70 / 21	1245	1075	1294	1099	1040	1188	990	975	1120	970	1002
	90 / 32	1194	1060	1258	1054	1025	1155	930	990	1060	905	925
<b>Evaporator Outlet Temp.</b>	50 / 10	16	24	19	16	24	19	18	24	21	24	23
	70 / 21	16	23	19	18	23	21	18	23	21	23	23
	90 / 32	16	28	19	18	28	21	19	28	23	28	23
<b>Pressure High Side</b>	50 / 10	210	264	215	240	264	228	270	264	240	264	275
	70 / 21	210	264	215	240	264	228	270	264	240	264	275
	90 / 32	210	265	215	240	265	228	270	265	240	265	275
<b>Pressure Suction</b>	50 / 10	35	40	36	38	40	38	40	40	40	40	42
	70 / 21	35	40	36	38	40	38	40	40	40	40	42
	90 / 32	35	43	36	38	43	38	40	43	40	43	42

**PERFORMANCE DATA**

MODEL: F-1501M\_H

Supply Voltage: 208-230/60/1 (3 wire w/neutral for 115V)

Total Amperage (Compressor RLA):

Air: 15.9A (9.3A)    Water: 15.4A (9.3A)    Remote: 18.4A (9.3A)

Water Consumption for MWH Condenser:

70/50 (21/10) 658 Gal/24hrs    80/70 (32/21) 974 Gal/24hrs

Kg=lbs x.454	70 / 21			80 / 27			90 / 32			100 / 38		
	Air	Water	Remote	Air	Water	Remote	Air	Water	Remote	Air	Water	Remote
<b>Production</b>	1590	1460	1585	1382	1374	1439	1206	1273	1309	1051	1180	1192
<b>24 hours</b>	1514	1446	1532	1321	1340	1394	1170	1265	1300	1005	1150	1155
<b>(lbs)</b>	1447	1409	1484	1262	1306	1351	1100	1210	1230	945	1095	1070
<b>Evaporator</b>	16	5	19	16	6	19	18	6	21	19	6	23
<b>Outlet</b>	16	5	19	18	6	21	18	6	21	19	6	23
<b>Temp. (F°)</b>	16	5	19	18	6	21	19	6	23	19	6	23
<b>Pressure</b>	210	270	215	240	272	228	270	274	240	310	276	275
<b>High Side</b>	210	270	215	240	273	228	270	275	240	310	276	275
	210	271	215	240	273	228	270	275	240	310	277	275
<b>Pressure</b>	35	38	36	38	38	38	40	39	40	42	39	42
<b>Suction</b>	35	38	36	38	38	38	40	39	40	42	39	42
	35	38	36	38	38	38	40	39	40	42	39	42

**PERFORMANCE DATA**

MODEL: F-1501M\_H-C

Supply Voltage: 208-230/60/1 (3 wire w/neutral for 115V)

Total Amperage (Compressor RLA):

Air: 15.6A (9.3A)    Water: 15.4A (9.3A)    Remote: 18.4A (9.3A)

Water Consumption for MWH-C Condenser:

70/50 (21/10)    617 Gal/24hrs    80 / 27    90 / 32    100 / 38

Ambient Temp (F°/C°)		70 / 21			80 / 27			90 / 32			100 / 38		
Kg=lbs x.454	Water Temp F°/C°	Air	Water	Remote	Air	Water	Remote	Air	Water	Remote	Air	Water	Remote
	<b>Production 24 hours (lbs)</b>	50 / 10	1300	1208	1335	1145	1158	1223	1011	1083	1123	892	1012
70 / 21		1245	1211	1294	1099	1132	1188	990	1096	1120	855	990	1002
90 / 32		1194	1184	1258	1054	1007	1155	930	1035	1060	800	928	925
<b>Evaporator Outlet Temp.</b>	50 / 10	16	6	19	16	6	19	18	6	21	19	6	23
	70 / 21	16	6	19	18	6	21	18	6	21	19	6	23
	90 / 32	16	6	19	18	6	21	19	6	23	19	6	23
<b>Pressure High Side</b>	50 / 10	210	270	215	240	272	228	270	273	240	310	275	275
	70 / 21	210	271	215	240	272	228	270	274	240	310	276	275
	90 / 32	210	271	215	240	273	228	270	275	240	310	277	275
<b>Pressure Suction</b>	50 / 10	35	36	36	38	36	38	40	37	40	42	38	42
	70 / 21	35	36	36	38	37	38	40	37	40	42	38	42
	90 / 32	35	36	36	38	37	38	40	37	40	42	39	42

**PERFORMANCE DATA**

MODEL: FS-1501MLH-C w/SRC-14H      Supply Voltage: 115/60/1  
 SRC Supply Voltage: 208-230/60/1 (3 wire w/neutral for 115V)  
 Total Amperage (Compressor RLA): Low Side MLH: 3.6A    SRC-14H condenser: 10.1A (6.9A)

Ambient Temp (F°/C°)		70 / 21	80 / 27	90 / 32	100 / 38
<b>Kg=lbs x.454 Production 24 hours (lbs)</b>	Water Temp F°/C°	Low Side	Low Side	Low Side	Low Side
	50 / 10	1491	1324	1163	1022
	70 / 21	1444	1268	1165	979
	90 / 32	1383	1215	1067	906
<b>Evaporator Outlet Temp.</b>	50 / 10	10	10	13	15
	70 / 21	10	13	13	15
	90 / 32	10	13	15	15
<b>Pressure High Side</b>	50 / 10	191	213	236	273
	70 / 21	191	213	236	273
	90 / 32	191	213	236	273
<b>Pressure Suction</b>	50 / 10	32	34	36	39
	70 / 21	32	34	36	39
	90 / 32	32	34	36	39

**PERFORMANCE DATA**

MODEL: F-2000M\_H (3)

Supply Voltage: 208-230/60/1 (3 wire w/neutral for 115V) 3 ϕ: 208-230/60/3

Total Amperage (Compressor RLA):

Water: 16.9A (10.8A) Remote: 19.4A (10.8A) Remote: 3 ϕ: 17.6A (9A)

Water Consumption for MWH Condenser: 70/50 (21/10) 981 Gal/24hrs 90/70 (32/21) 1374 Gal/24hrs

Kg=lbs x.454 Production 24 hours (lbs)	70 / 21			80 / 27			90 / 32			100/38		
	Water Temp F°/C°	Water	Remote	(3)	Water	Remote	(3)	Water	Remote	(3)	Water	Remote
50 / 10	2030	1990	2010	1876	1825	1845	1760	1685	1700	1650	1550	1550
70 / 21	1955	1930	1950	1835	1775	1795	1730	1675	1695	1615	1510	1525
90 / 32	1915	1880	1880	1795	1730	1750	1685	1595	1610	1500	1395	1410
<b>Evaporator Outlet Temp.</b>	50 / 10	11	12	14	11	12	14	11	12	14	11	14
	70 / 21	11	12	14	11	12	14	11	12	14	11	14
	90 / 32	11	12	14	11	12	14	11	14	11	14	14
<b>Pressure High Side</b>	50 / 10	262	221	219	262	230	262	238	241	262	274	271
	70 / 21	263	221	219	263	230	263	238	241	263	274	271
	90 / 32	265	221	219	265	230	265	238	241	265	274	271
<b>Pressure Suction</b>	50 / 10	26	25	25	26	26	26	26	27	26	29	29
	70 / 21	27	25	25	27	26	27	26	27	27	29	29
	90 / 32	28	25	25	28	26	28	26	27	28	29	29

**PERFORMANCE DATA**

MODEL: F-2000M\_H-C (3)

Supply Voltage: 208-230/60/1 (3 wire w/neutral for 115V) 3 Ø: 208-230/60/3

Total Amperage (Compressor RLA):

Water: 10.8A (6.11A) Remote: 10.8A (5.6A) Remote: 3 Ø: 18.6A (9A)

Water Consumption for MWH-C Condenser:

70/50 (21/10) 735 Gal/24hrs 90/70 (32/21) 1165 Gal/24hrs

Ambient Temp (F°/C°)		70/21			80/27			90 / 32			100 /38		
Kg=lbs x.454 Production 24 hours (lbs)	Water Temp F°/C°	Water	Remote (3)	Water	Remote (3)	Water	Remote (3)	Water	Remote (3)	Water	Remote (3)	Water	Remote (3)
		50 / 10	1790	1715 (1725)	1670	1595 (1615)	1585	1500 (1515)	1510	1410 (1420)			
	70 / 21	1725	1660 (1685)	1640	1560 (1580)	1560	1490 (1525)	1485	1380 (1390)				
	90 / 32	1700	1630 (1650)	1615	1530 (1545)	1535	1435 (1450)	1375	1270 (1275)				
<b>Evaporator Outlet Temp.</b>	50 / 10	10	12	10	12	10	14	10	14				
	70 / 21	10	12	10	14	10	14	10	14				
	90 / 32	12	12	12	14	12	14	12	14				
<b>Pressure High Side</b>	50 / 10	262	220	262	227	262	233	262	266				
	70 / 21	263	220	263	227	263	233	263	266				
	90 / 32	266	220	266	227	266	233	266	266				
<b>Pressure Suction</b>	50 / 10	27	26	27	26	27	27	27	29				
	70 / 21	27	26	27	26	27	27	27	29				
	90 / 32	28	26	28	26	28	27	28	29				

**PERFORMANCE DATA**

MODEL: F-2001M\_H(3)

Supply Voltage: 208-230/60/1 (3 wire w/neutral for 115V) 3 ∅: 208-230/60/3

Total Amperage (Compressor RLA):

Water: 16.9A (10.8A) Remote: 19.9A (10.8) Remote: 3 ∅: 18.1A (9A)

Water Consumption for MWH-C Condenser:

70/50 (21/10) 981 Gal/24hrs 90/70 (32/21) 1374 Gal/24hrs

Ambient Temp (F°/C°)		70/21			80/27			90/32			100/38		
Kg=lbs x.454 Production 24 hours (lbs)	Water Temp F°/C°	Water	Remote (3)	Water	Remote (3)	Water	Remote (3)	Water	Remote (3)	Water	Remote (3)	Water	Remote (3)
		50/10	2030	1990 (2010)	1875	1825 (1845)	1760	1685 (1700)	1510	1650 (1570)			
	70/21	1955	1930 (1950)	1835	1775 (1795)	1642	1592 (1608)	1485	1615 (1525)				
	90/32	1915	1880 (1895)	1795	1730 (1750)	1685	1595 (1610)	1375	1500 (1410)				
Evaporator Outlet Temp.	50/10	11	12 (14)	11	12 (14)	11	12 (14)	11	14(16)				
	70/21	11	12 (14)	11	12 (14)	11	12 (14)	11	14 (16)				
	90/32	11	12 (14)	11	12 (14)	11	14 (16)	11	14 (16)				
Pressure High Side	50/10	262	221 (219)	262	230 (230)	262	238 (241)	262	274 (271)				
	70/21	263	221 (219)	263	230 (230)	263	238 (241)	263	274 (271)				
	90/32	265	221 (219)	265	230 (230)	265	238 (241)	265	274 (271)				
Pressure Suction	50/10	26	25 (25)	26	26 (26)	26	26 (27)	26	29 (29)				
	70/21	27	25 (25)	27	26 (26)	27	26 (27)	27	29 (29)				
	90/32	28	25 (25)	28	26 (26)	28	26 (27)	28	29 (29)				

## PERFORMANCE DATA

MODEL: F-2001MRH-C

Supply Voltage: 208-230/60/1 (3 wire w/neutral for 115V)

Total Amperage (Compressor RLA): Remote: 19.9A (10.8A)

Ambient Temp (F°/C°)		70 / 21	80 / 27	90 / 32	100 / 38
<b>Kg=lbs x.454 Production 24 hours (lbs)</b>	Water Temp F°/C°	Remote	Remote	Remote	Remote
	50 / 10	1814	1652	1515	1390
	70 / 21	1749	1605	1496	1350
	90 / 32	1700	1559	1430	1253
<b>Evaporator Outlet Temp.</b>	50 / 10	1	5	3	3
	70 / 21	2	1	4	3
	90 / 32	4	3	2	6
<b>Pressure High Side</b>	50 / 10	199	199	199	199
	70 / 21	245	245	245	245
	90 / 32	274	274	274	274
<b>Pressure Suction</b>	50 / 10	22	22	22	22
	70 / 21	25	25	25	25
	90 / 32	27	27	27	27



**PERFORMANCE DATA**

MODEL: F-2000MLH (-C), F-2001MLH

Supply Voltage: 115/60/1

Total Amperage : 6.11A This unit designed for connected to a rack system using R-404A. The data below is calculated.

Ambient Temp (F°/C°)	70 / 21			80 / 27			90 / 32			100 / 38		
	Water Temp F°/C°	Remote	-C	Remote	-C	Remote	-C	Remote	-C	Remote	-C	
<b>Kg=lbs x.454</b>												
<b>Production</b>	50 / 10	2280	1965	2010	1755	1760	1565	1650	1500			
<b>24 hours</b>	70 / 21	1955	1680	1835	1615	1730	1540	1615	1475			
<b>(lbs)</b>	90 / 32	1915	1660	1795	1585	1685	1515	1370	1245			
<b>Evaporator</b>	50 / 10	12	12	12	12	12	12	14	14			
<b>Outlet</b>	70 / 21	12	12	12	12	12	12	14	14			
<b>Temp.</b>	90 / 32	12	12	12	12	14	14	14	14			
<b>Pressure</b>	50 / 10	190	190	190	190	190	190	190	190			
<b>High Side</b>	70 / 21	256	256	256	256	256	256	256	256			
	90 / 32	297	297	297	297	297	297	297	297			
<b>Pressure</b>	50 / 10	16	16	16	16	16	16	16	16			
<b>Suction</b>	70 / 21	21	21	21	21	21	21	21	21			
	90 / 32	22	22	22	22	22	22	22	22			

**Note:** The data provided is calculated by using a refrigeration capacity of 11600 BTU/h with a high side pressure of 221PSIG and suction pressure of 22 PSIG. The actual production and system operating pressures will vary depending on the specific R-404A rack system setup.

Factory setting for the Evaporator Pressure Regulating Valve (EPR) is 22 PSIG for an evaporator temperature no less than -14 °F (-25 °C).

## Flaker/DCM Wiring Diagram Reference Chart

Note: All capacitor values are in MFD.

Model	Wiring Diagram	Page	Start Capacitor	Run Capacitor	Fan Capacitor	Gear Motor Capacitor
C-101BAH	A	365	None	None	None	10
DCM-270BAH	B	366	145~174	None	None	10
DCM-270BAH-OS	C	367	145~174	None	None	10
DCM-500BAH, DCM-500BWH	D	368	243~292	15	5	20
DCM-500BAH-OS, DCM-500BWH-OS	E	369	243~292	15	5	20
DCM-750BAH, DCM-750BWH	F	370	189~227	25	5	24
DCM-750BAH-OS, DCM-750BWH-OS	G	371	189~227	25	5	24
DCM-751BAH, DCM-751BWH	H	372	243~292	40	5	24
DCM-751BAH-OS, DCM-751BWH-OS	I	373	243~292	40	5	24
DT-400BAH-OS	J	374	243~292	15	5	20
F-300BAF	K	375	243~292	35	None	10
F-330BAH(-C)	L	376	280	None	None	10

## Flaker/DCM Wiring Diagram Reference Chart

Note: All capacitor values are in MFD.

Model	Wiring Diagram	Page	Start Capacitor	Run Capacitor	Fan Capacitor	Gear Motor Capacitor
F-450MAH(-C)	M	377	243~292	15	5	20
FD-650MAH(-C), FD-650MWH(-C), {FD-650MRH(-C)}	N	378	243~292	35	5 {10}	10
F-800MAH(-C), F-800MWH(-C)	O	379	189~277	25	5	12
F-801MAH(-C), F-801MWH(-C)	O	379	243~292	15	5	24
F-1001M_H(-C)	P	380	108~130	25	5	24
FD-1001MAH(-C), FD-1001MWH(-C), {FD-1001MRH(-C)}	Q	381	108~130	25	5 {10}	24
F-1001MAJ(-C), F-1001MWH(-C), {F-1001MRH(-C)}	R	382	304~400	40	5 {10}	24
F-1001MLH(-C)	S	383	None	None	None	65
F-1001MLJ(-C)	T	384	None	None	None	24
F-2001MLJ(-C)	T	384	None	None	None	65
FS-1001MLH(-C)	S	383	None	None	None	24

## Flaker/DCM Wiring Diagram Reference Chart

Note: All capacitor values are in MFD.

Model	Wiring Diagram	Page	Start Capacitor	Run Capacitor	Fan Capacitor	Gear Motor Capacitor
FS-1001MLH(-C)	U	385	None	None	None	24
FS-1001MLH-C, FS-1022MLH-C	V	386	None	None	None	24
FS-1500MLH-C	V	386	None	None	None	65
SRC-10H / SRC-14H	W	387	108~130/145~174	30	10	None
F-1500M_H(-C), F-A Board	X	388	147~174	30	10	65
F-1500MAH(-C), F-1500MWH(-C), {F-1500MRH(-C)}	Y	389	147~174	30	5 {10}	65
F-2000MWH(-C), F-2000MRH(-C)	Z	390	189~227	40	10	65
F-2000MWH3(-C), F-2000MRH3(-C)	AA	391	None	None	10	65
F-2000MLH(-C)	BB	392	None	None	None	65
F-2001MWH, F-2001MRH(-C)	CC	393	189~227	40	10	65
F-2001MWH3, F-2001MRH3(-C)	CC	393	None	None	10	65

# A C-101BAH

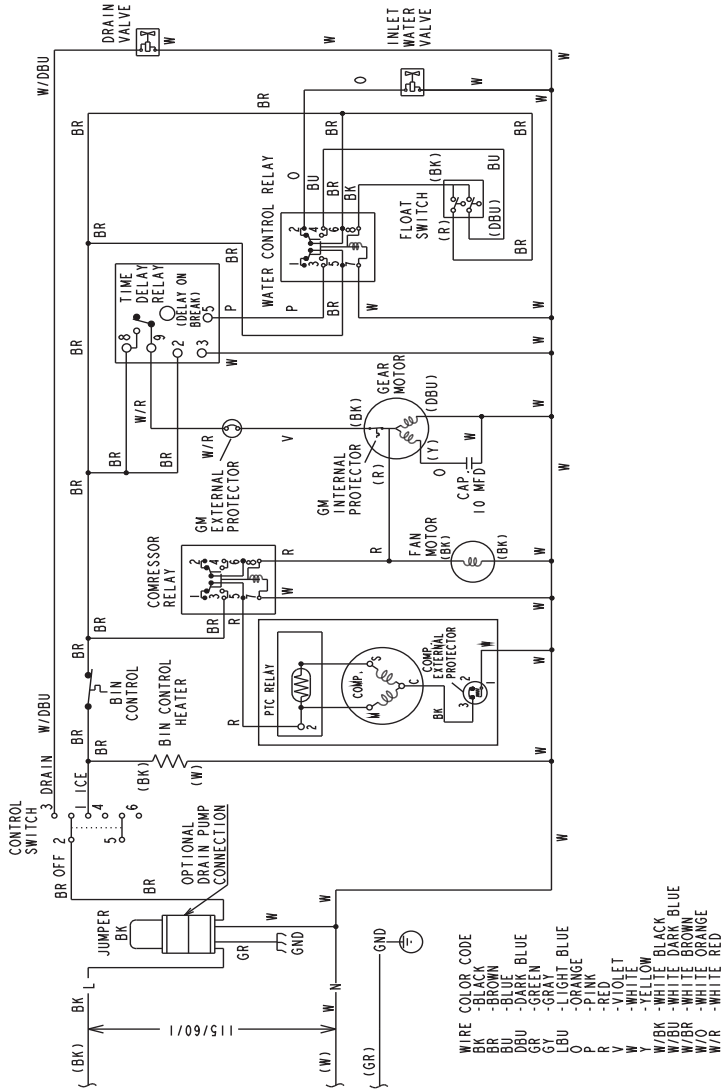

# B

## DCM-270BAH

**WIRE COLOR CODE**

- BR - BROWN
- BK - BLACK
- DBU - DARK BLUE
- LBU - LIGHT BLUE
- GY - GREY
- O - ORANGE
- P - PINK
- R - RED
- V - VIOLET
- W - WHITE
- Y - YELLOW
- W/BK - WHITE/BLACK
- W/BR - WHITE/BROWN
- W/BU - WHITE/BLUE
- W/O - WHITE/ORANGE
- W/R - WHITE/RED

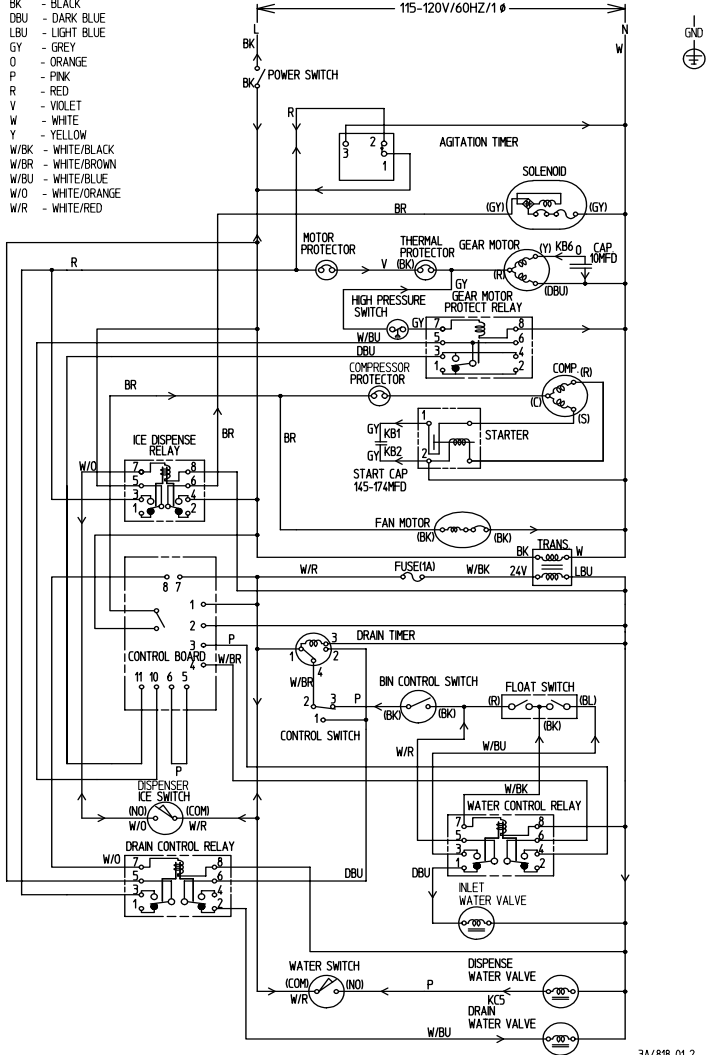

3A4818-01 2

# C DCM-270BAH-OS

WIRE COLOR CODE	
BR	BROWN
BK	BLACK
DBU	DARK BLUE
LBU	LIGHT BLUE
GY	GRAY
O	ORANGE
P	PINK
R	RED
V	VIOLET
W	WHITE
Y	YELLOW
W/BK	WHITE/BLACK
W/BR	WHITE/BROWN
W/BU	WHITE/BLUE
W/O	WHITE/ORANGE
W/R	WHITE/RED

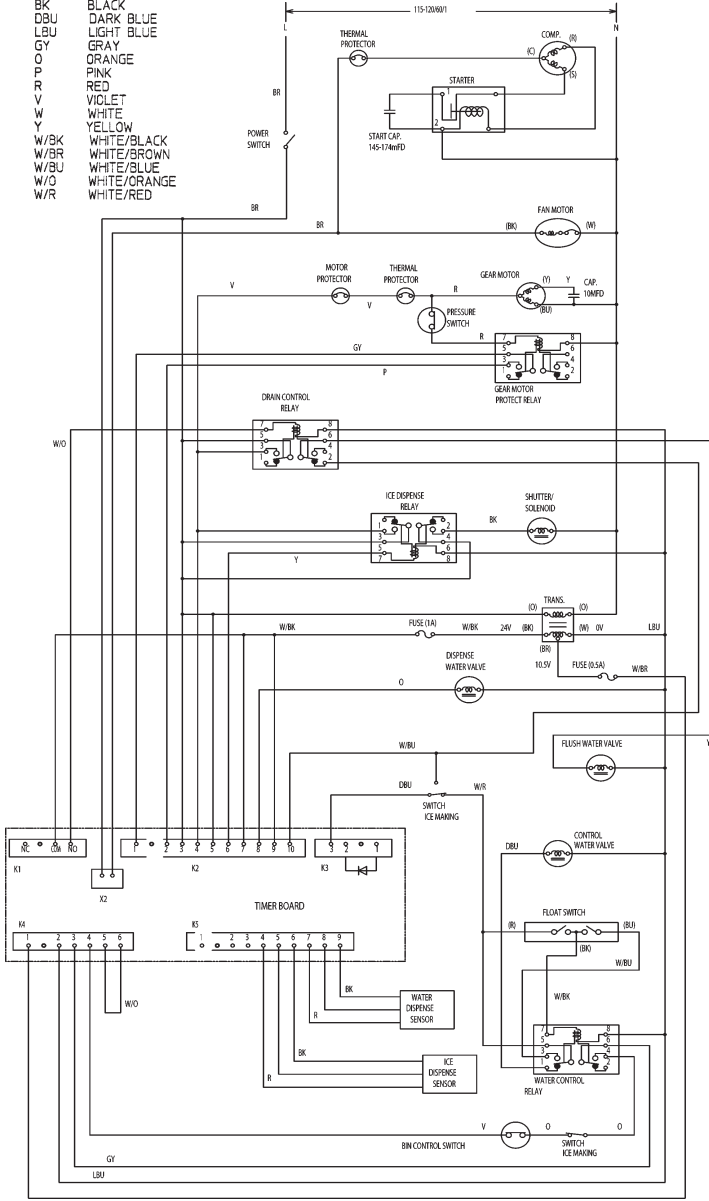

# D

## DCM-500BAH, DCM-500BWH

**WIRE COLOR CODE**

- BK -BLACK
- BR -BROWN
- BU -BLUE
- DBU -DARK BLUE
- GY -GRAY
- LBU -LIGHT BLUE
- O -ORANGE
- P -PINK
- R -RED
- V -VIOLET
- W -WHITE
- Y -YELLOW

**WIRING DIAGRAM**

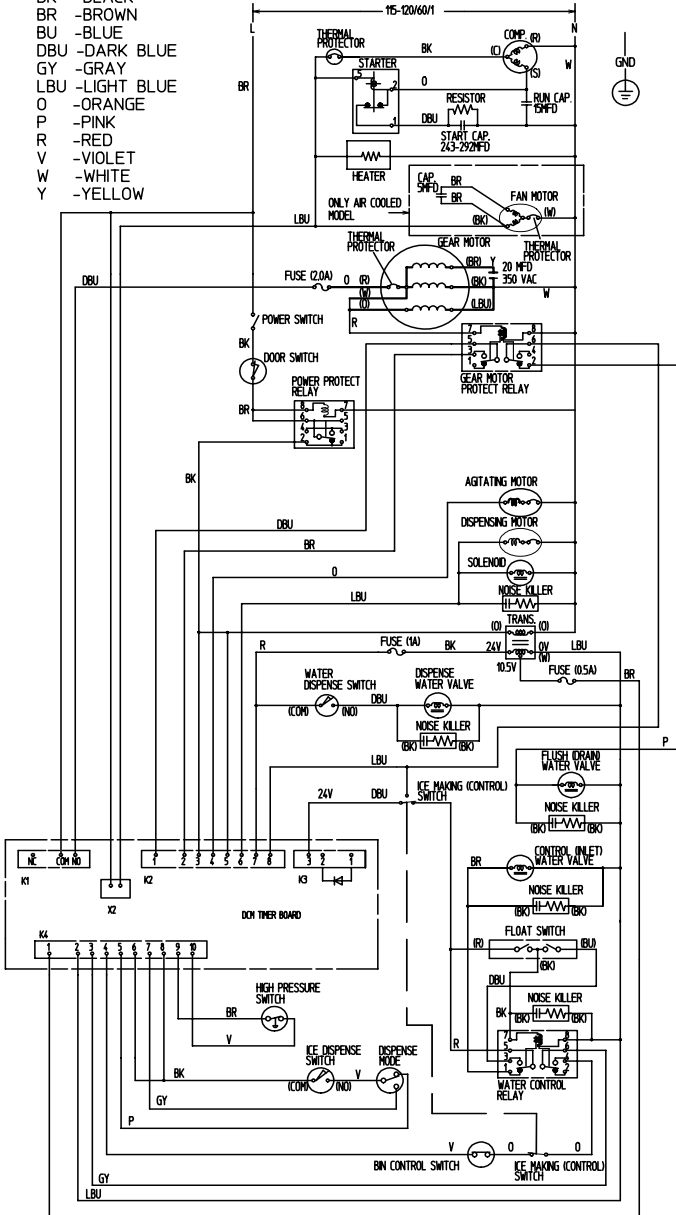

3A44



# E

## DCM-500BAH-OS, DCM-500BWH-OS

### WIRE COLOR CODE

BK	BLACK
BR	BROWN
BU	BLUE
DBU	DARK BLUE
GY	GRAY
LBU	LIGHT BLUE
O	ORANGE
P	PINK
R	RED
V	VIOLET
W	WHITE
Y	YELLOW
W/BK	WHITE/BLACK
W/BR	WHITE/BROWN
W/BU	WHITE/BLUE
W/O	WHITE/ORANGE
W/R	WHITE/RED

### WIRING DIAGRAM

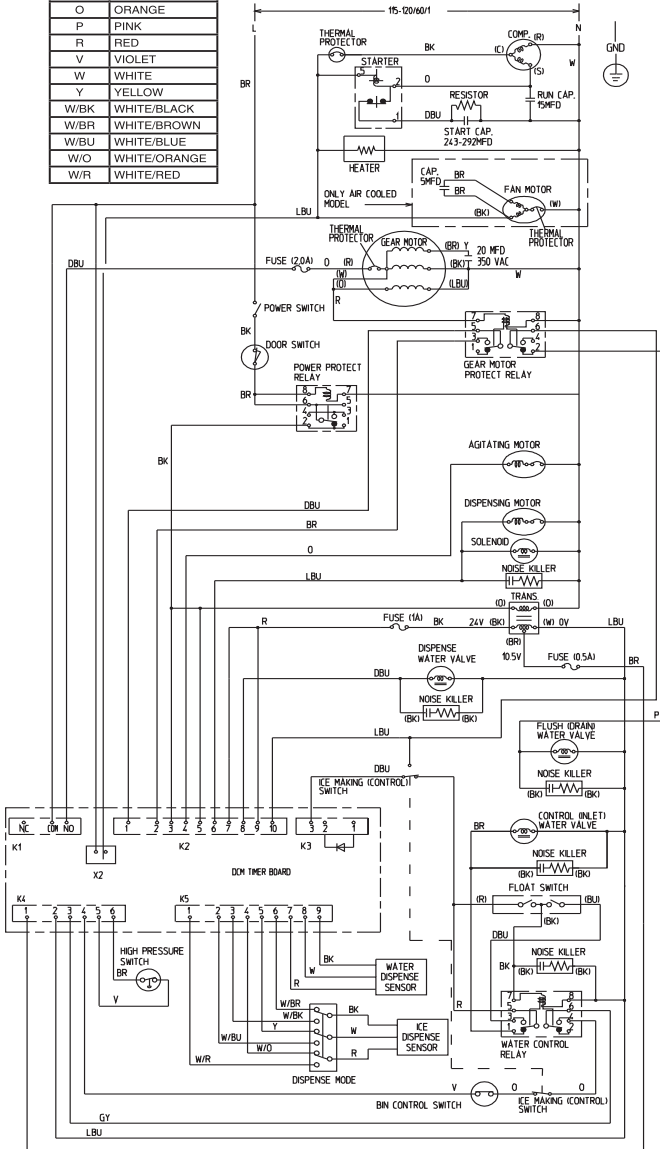

# F

## DCM-750BAH, DCM-750BWH

**WIRE COLOR CODE**

- BK -BLACK
- BR -BROWN
- BU -BLUE
- DBU -DARK BLUE
- GY -GRAY
- LBU -LIGHT BLUE
- O -ORANGE
- R -RED
- V -VIOLET
- W -WHITE

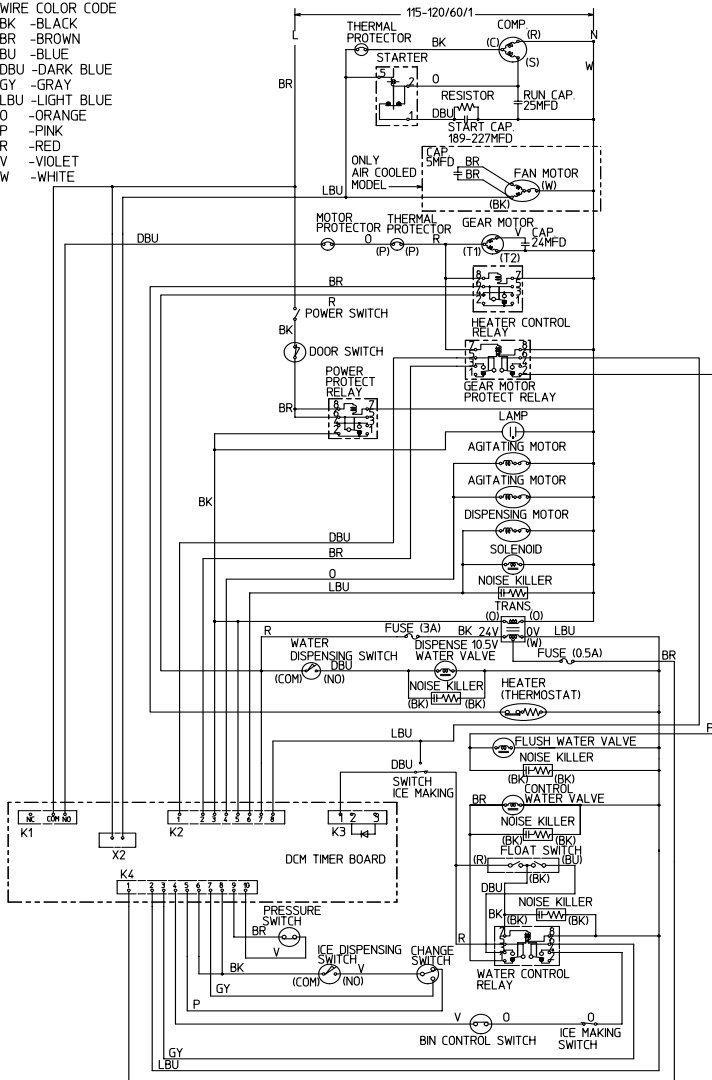

3A1530-011

# G

## DCM-750BAH-OS, DCM-750BWH-OS

- WIRE COLOR CODE
- |                 |                   |
|-----------------|-------------------|
| BK -BLACK       | W/BK -WHITE/BLACK |
| BR -BROWN       | W/BR -WHITE/BROWN |
| BU -BLUE        | W/BU -WHITE/BLUE  |
| DBU -DARK BLUE  | W/O -WHITE/ORANGE |
| GY -GRAY        | W/R -WHITE/RED    |
| LBU -LIGHT BLUE |                   |
| O -ORANGE       |                   |
| P -PINK         |                   |
| R -RED          |                   |
| V -VIOLET       |                   |
| W -WHITE        |                   |

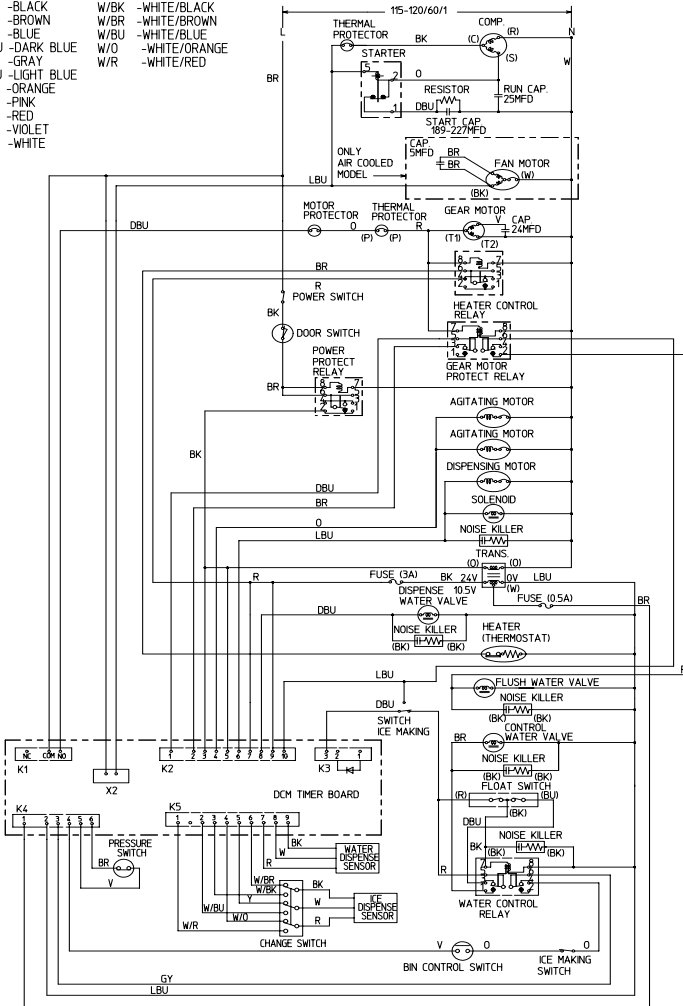

3A256

# H

## DCM-751BAH, DCM-750BWH

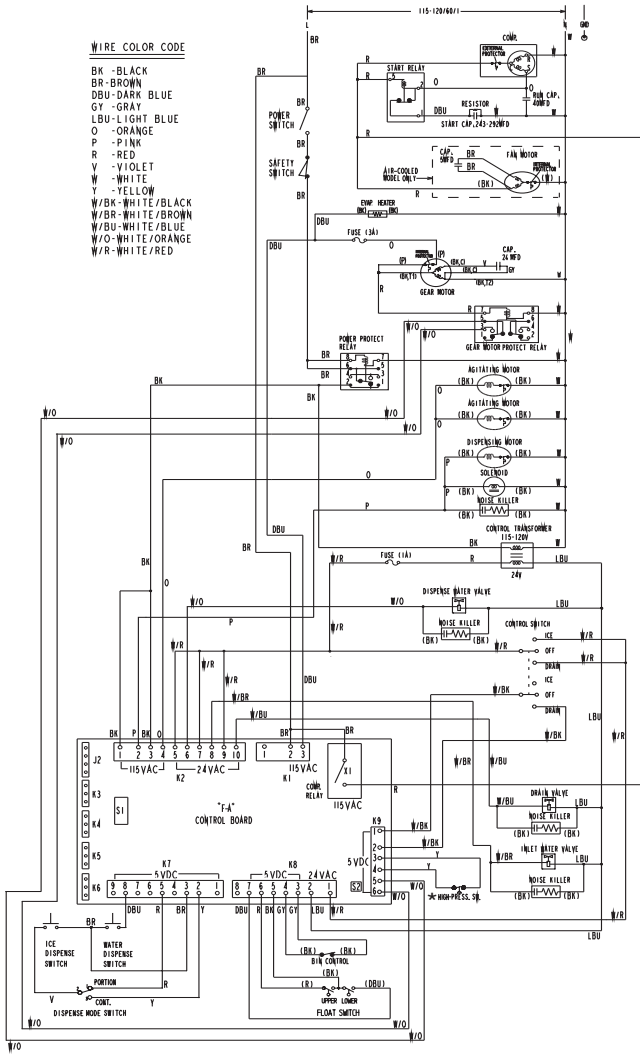

S I D I P SWITCH										
S I D I P SWITCH NO.	1	2	3	4	5	6	7	8	9	10
DCM-751B_H	OFF	OFF	OFF	OFF	ON	ON	OFF	ON	OFF	OFF

* High Pressure Switch		
	Air-Cooled Model	Water-Cooled Model
Cut-out	412± <sup>21</sup> <sub>0</sub> PSIG	384± <sup>21</sup> <sub>0</sub> PSIG
Cut-in	327±21 PSIG	284±21 PSIG

# DCM-751BAH-OS, DCM-751BWH-OS

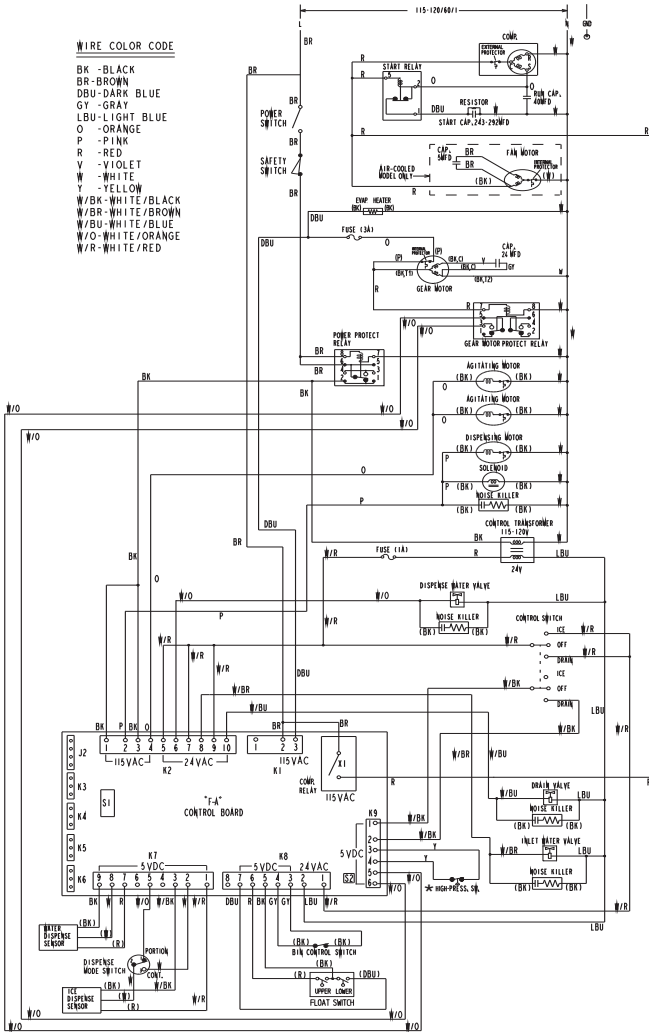

S1 D I P SWITCH										
S1 D I P SWITCH NO.	1	2	3	4	5	6	7	8	9	10
DCM-751B_H-OS	OFF	OFF	OFF	OFF	OFF	ON	OFF	ON	OFF	OFF

* High Pressure Switch		
	Air-Cooled Model	Water-Cooled Model
Cut-out	412± <sup>21</sup> <sub>0</sub> PSIG	384± <sup>21</sup> <sub>0</sub> PSIG
Cut-in	327±21 PSIG	284±21 PSIG

# J DT-400BAH-OS

- |     |            |      |              |
|-----|------------|------|--------------|
| BK  | BLACK      | W/R  | WHITE/RED    |
| BR  | BROWN      | W/BR | WHITE/BROWN  |
| DBU | DARK BLUE  | W/O  | WHITE/ORANGE |
| GY  | GRAY       | W/BU | WHITE/BLUE   |
| LBU | LIGHT BLUE | W/BK | WHITE/BLACK  |
| Y   | YELLOW     |      |              |
| O   | ORANGE     |      |              |
| P   | PINK       |      |              |
| R   | RED        |      |              |
| V   | VIOLET     |      |              |
| W   | WHITE      |      |              |

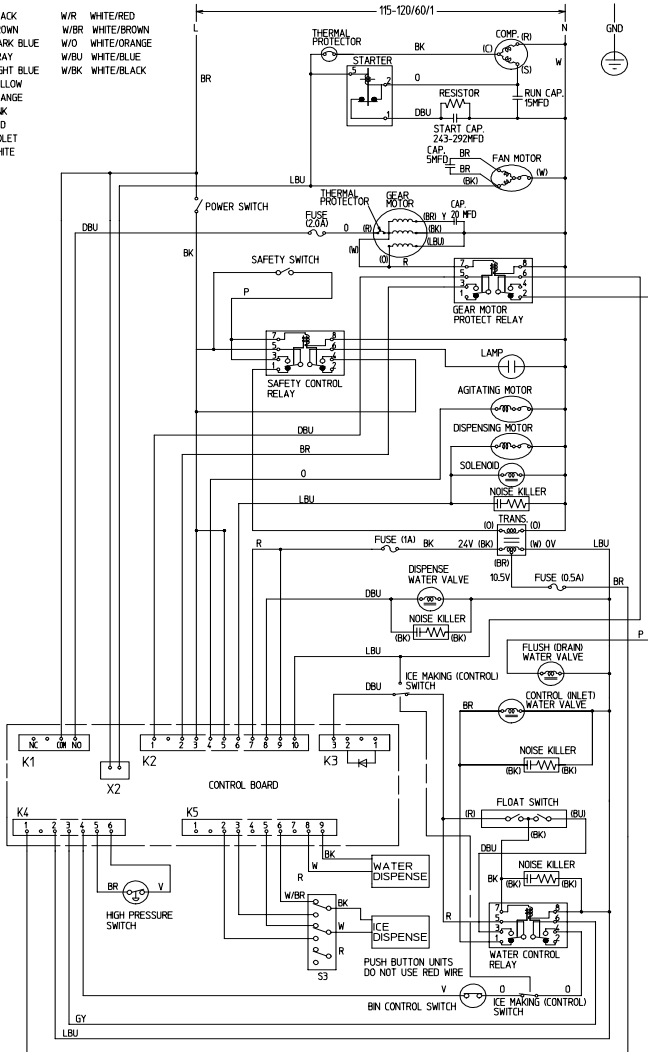

3A4822-011

# K F-300BAF

BR	BROWN	Y	YELLOW
W	WHITE	LBU	LIGHT BLUE
BK	BLACK	BLU	BLUE
R	RED	W/BR	WHITE/BROWN
O	ORANGE	W/BK	WHITE/BLACK
GY	GRAY	W/R	WHITE/RED
P	PINK	W/O	WHITE/ORANGE
DBU	DARK BLUE	W/BU	WHITE/BLUE
V	VIOLET		

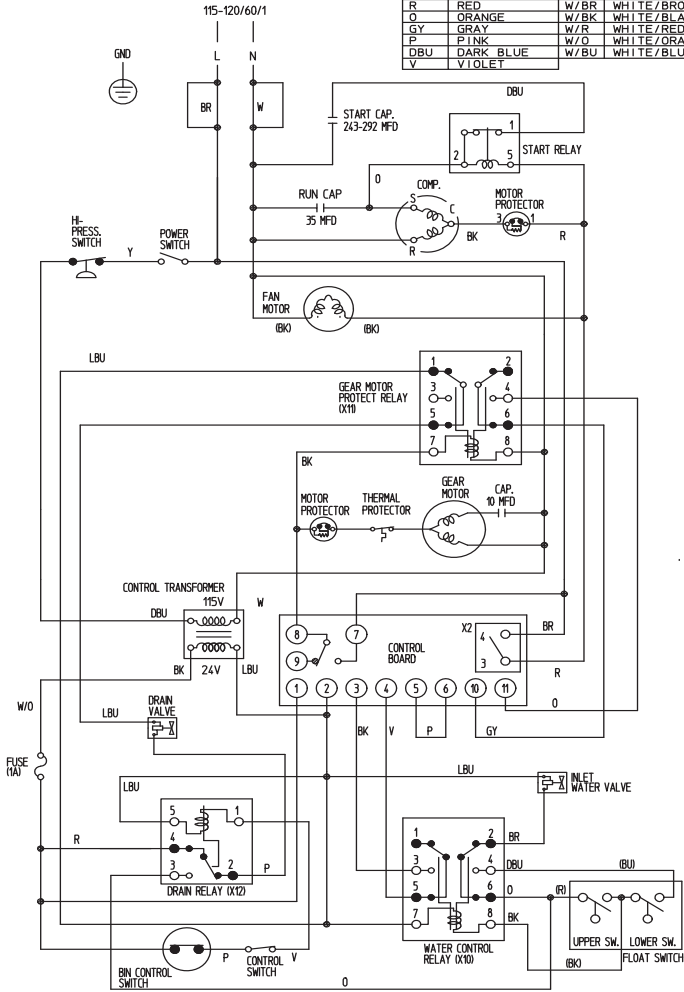

# L F-330BAH(-C)

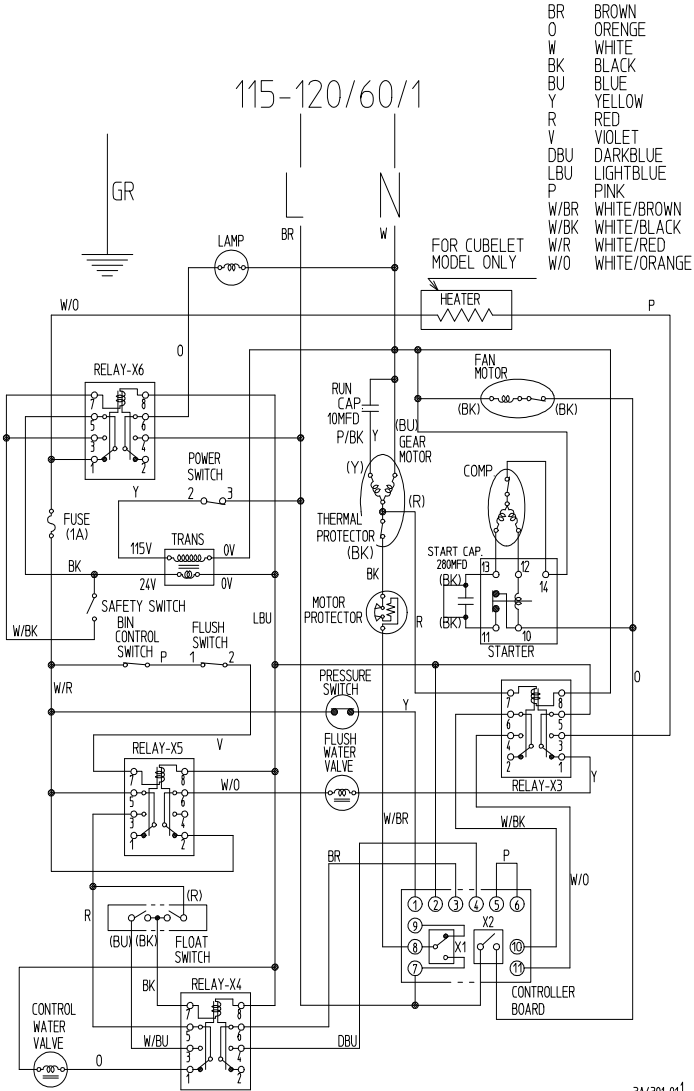



# M F-450MAH-C

BR. . . BLACK	O. . . ORANGE
BR. . . BROWN	P. . . PINK
DBU. DARK BLUE	R. . . RED
GY. . . GRAY	V. . . VIOLET
LBU. LIGHT BLUE	W. . . WHITE
	Y. . . YELLOW

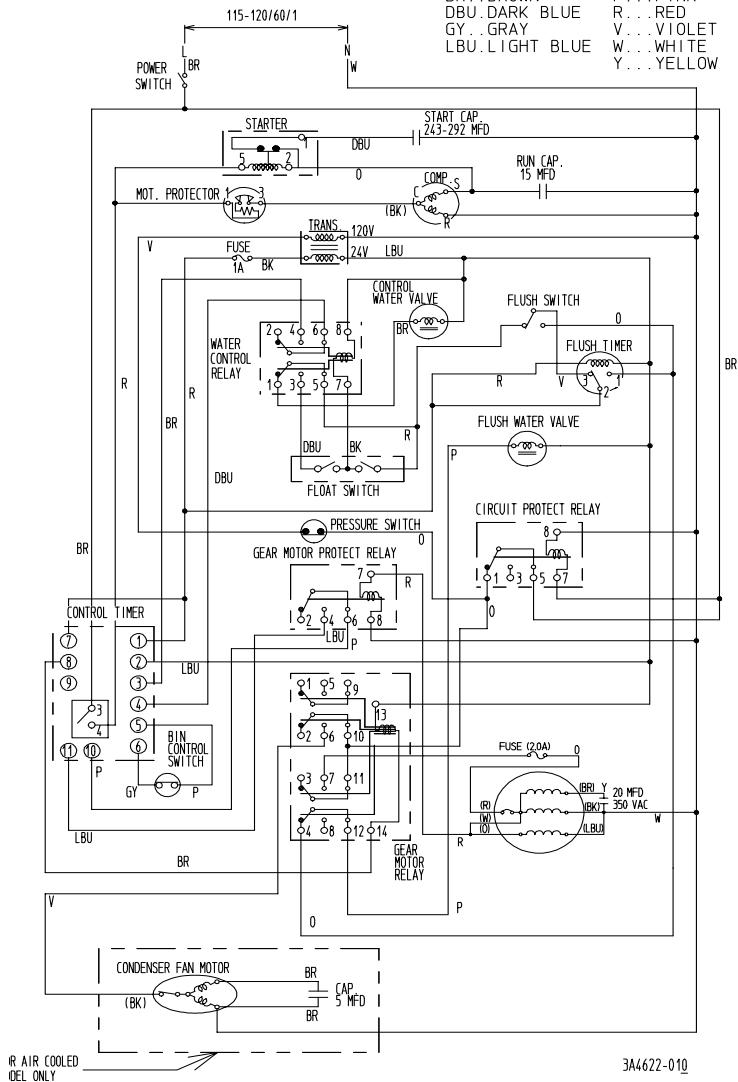

# N

## FD-650MAH-C, FD-650MWH-C, FD-650MRH-C

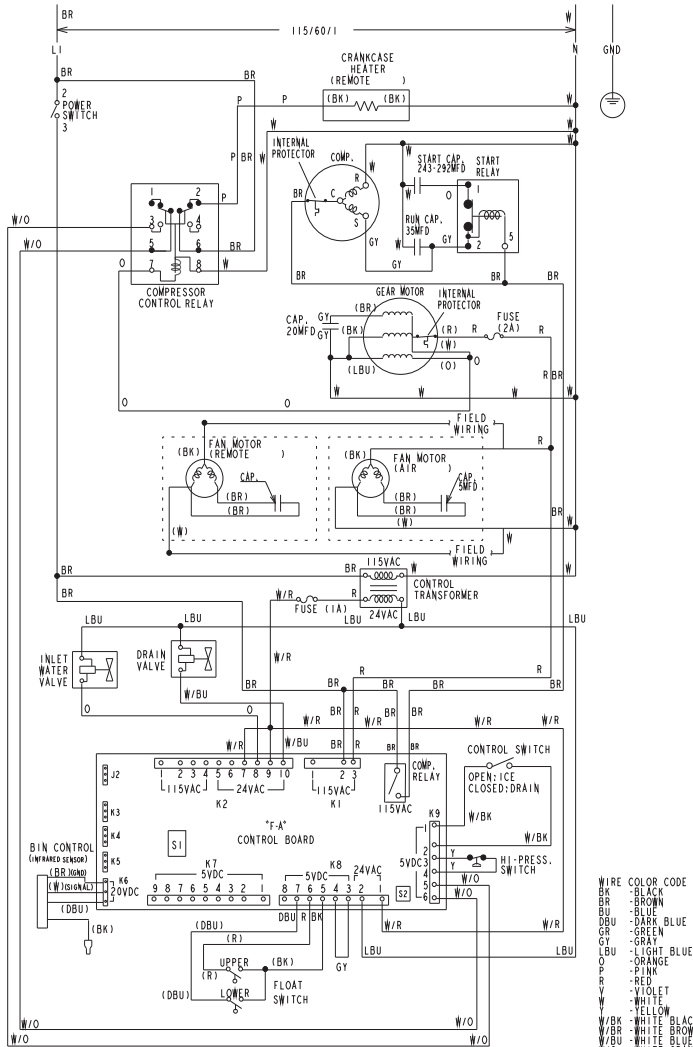

S1 DIP SWITCH SETTING	1	2	3	4	5	6	7	8	9	10
FD-650M-H-C	ON	OFF	OFF	OFF	OFF	OFF	ON	ON	OFF	OFF

# O

## F-800MAH(-C), F-800MWH(-C), F-801MAH/-C, F-801MWH/-C

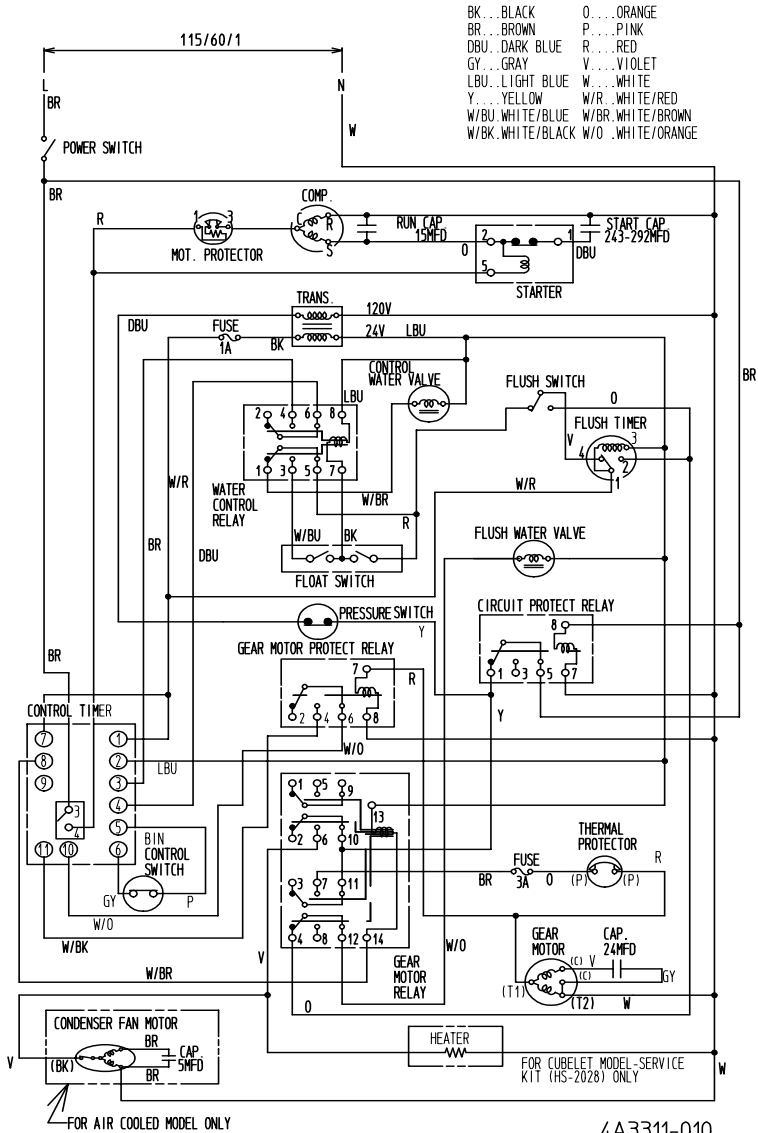

**Note: Drawing shown is F-801MAH/MWH.**  
**For F-800MAH/MWH, start capacitor is 187~277MFD, run capacitor is 25MFD.**

# P

## F-1001MAH(-C), MWH(-C), MRH(-C)

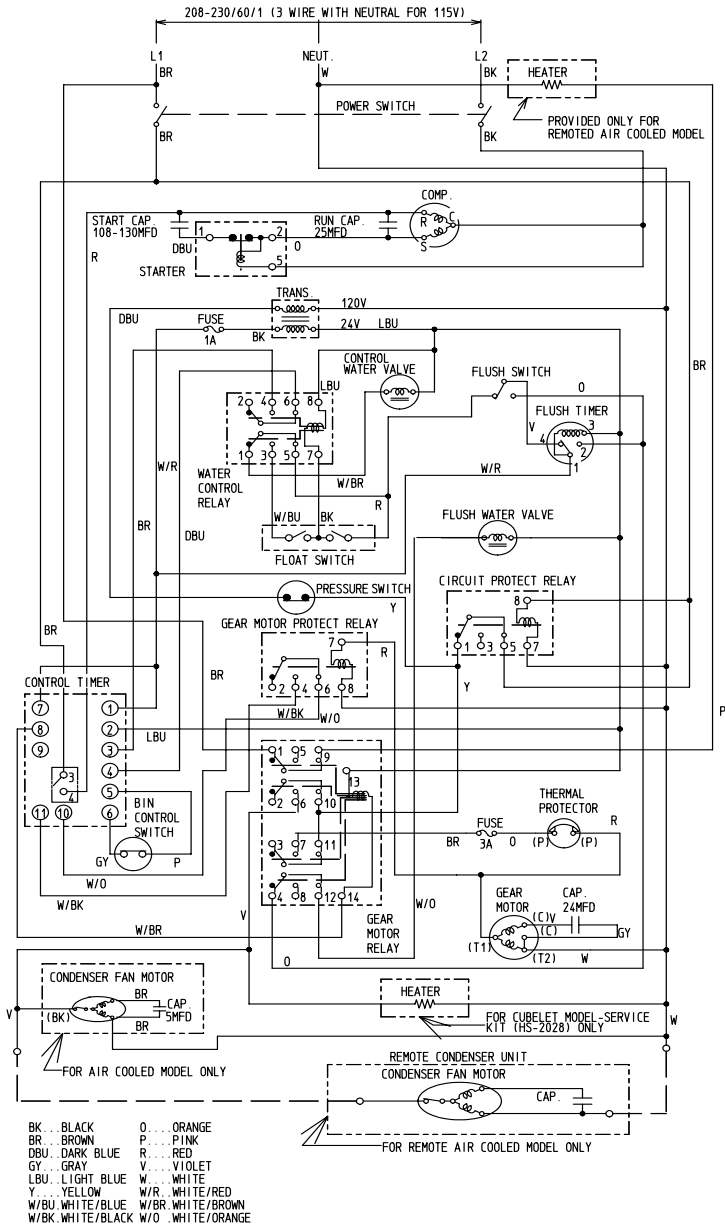

# O FD-1001M\_H-C with F-A Board

WIRING COLOR CODE			
O	ORANGE	GY	GRAY
GR	GREEN	DBU	DARK BLUE
P	PINK	LBU	LIGHT BLUE
BK	BLACK	W/BR	WHITE/BROWN
BR	BROWN	W/B	WHITE/BLACK
W	WHITE	W/O	WHITE/ORANGE
R	RED		

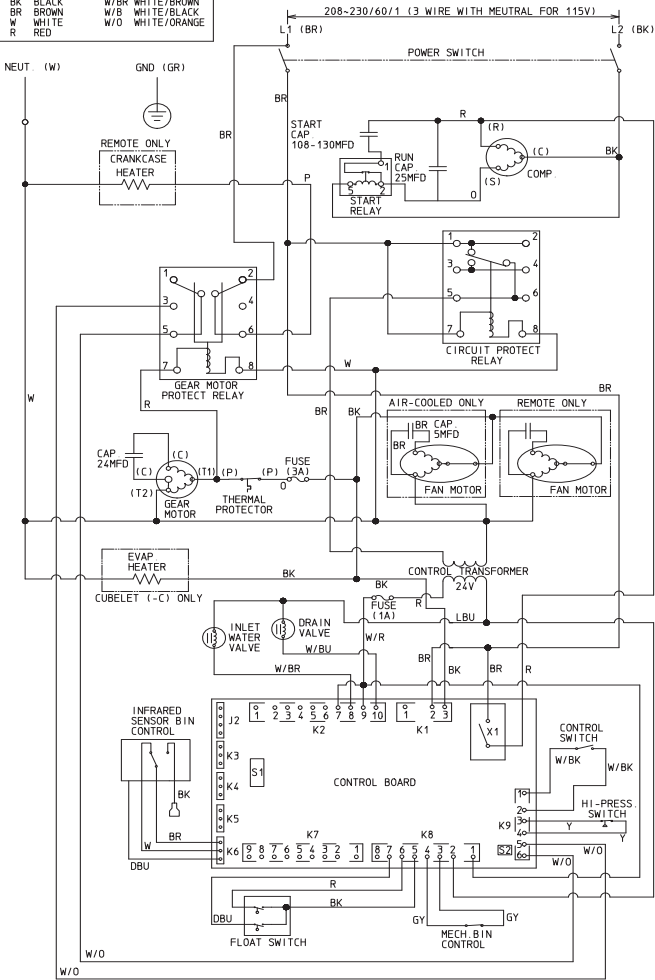

# R F-1001M\_J(-C)

SI DIP SWITCH SETTING	1	2	3	4	5	6	7	8	9	10
F-1001M_J / -C	OFF	OFF	OFF	OFF	OFF	OFF	OFF	OFF	OFF	OFF

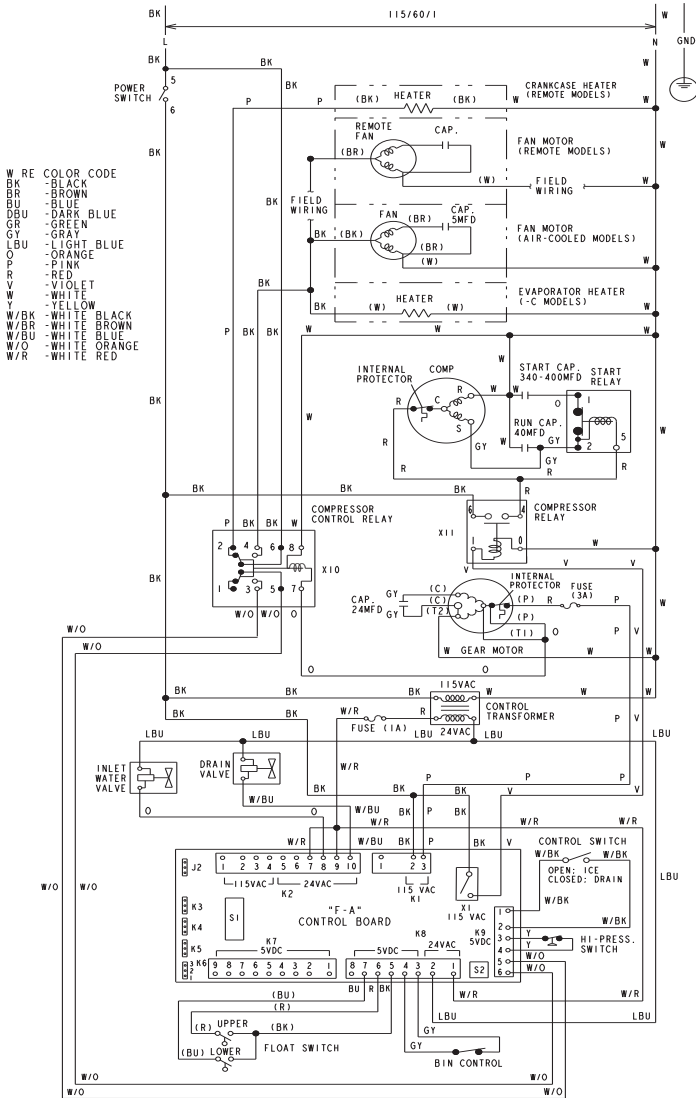

# S F-1001MLH/-C,

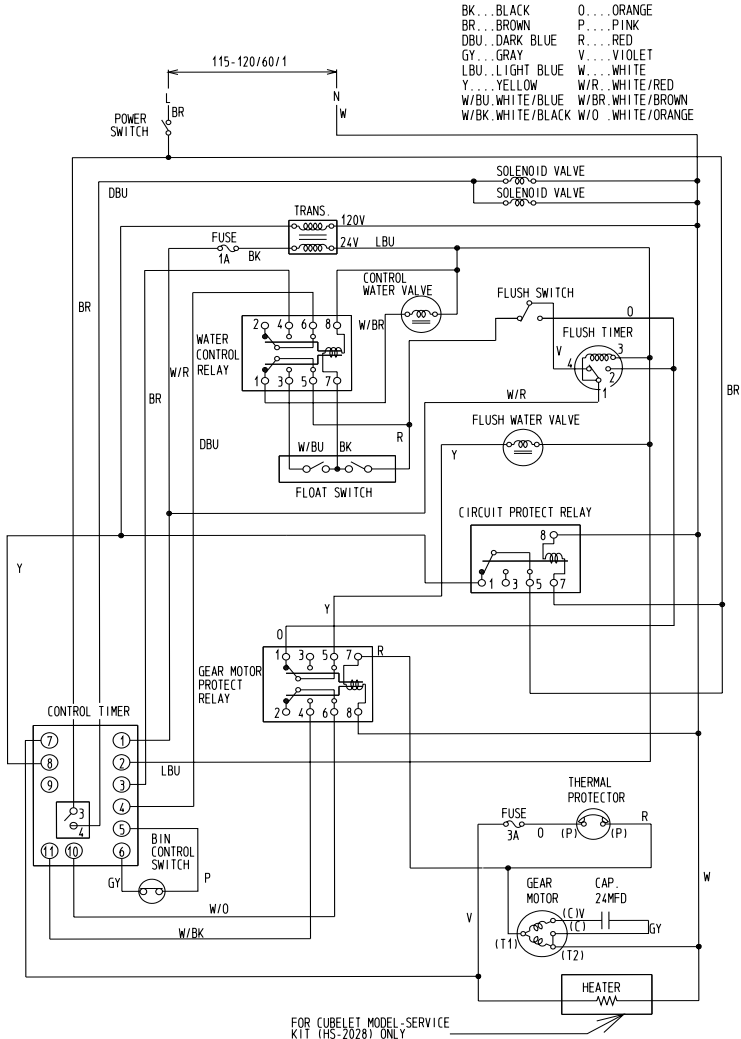

# T

## F-1001MLJ(-C), F-2001MLJ(-C)

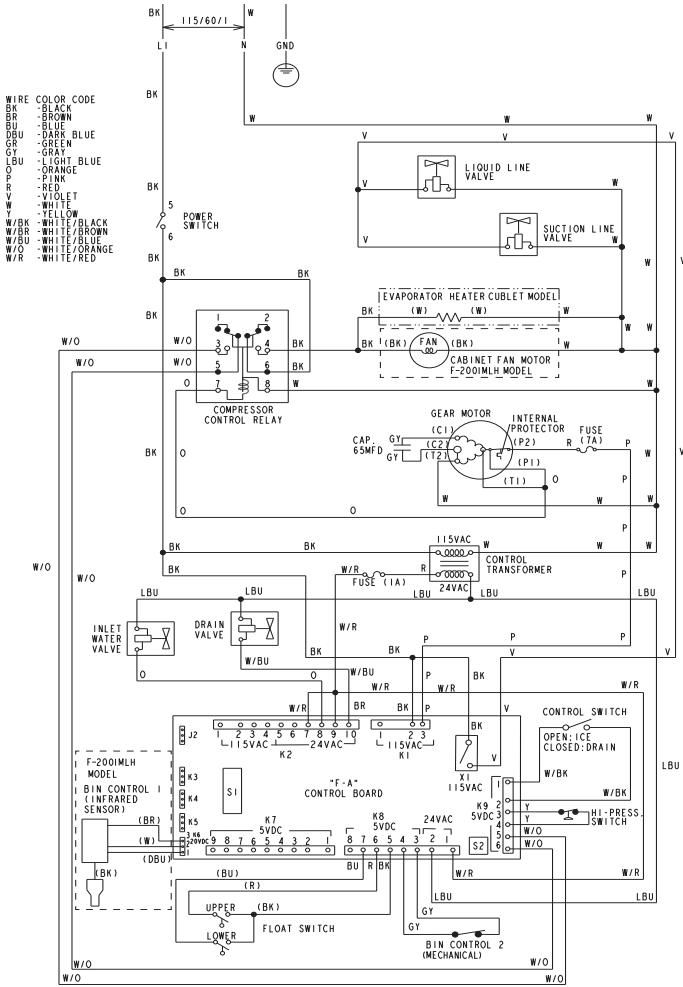

SI DIP SWITCH SETTING	1	2	3	4	5	6	7	8	9	10
F-1001MLJ(-C)	OFF	OFF	OFF	OFF	OFF	OFF	OFF	OFF	OFF	OFF
F-2001MLJ(-C)	ON	OFF	OFF	OFF	OFF	OFF	OFF	ON	OFF	OFF

**GEAR MOTOR CAPACITOR FOR F-1001MLJ IS 24 MFD.  
GEAR MOTOR CAPACITOR FOR F-2001MLJ IS SHOWN (65 MFD).**



# U FS-1001 MLH/-C

- |                    |                    |
|--------------------|--------------------|
| BK...BLACK         | O...ORANGE         |
| BR...BROWN         | P...PINK           |
| DBU...DARK BLUE    | R...RED            |
| GY...GRAY          | V...VIOLET         |
| LBU...LIGHT BLUE   | W...WHITE          |
| Y...YELLOW         | W/R...WHITE/RED    |
| W/BU...WHITE/BLUE  | W/BR...WHITE/BROWN |
| W/BK...WHITE/BLACK | W/O...WHITE/ORANGE |

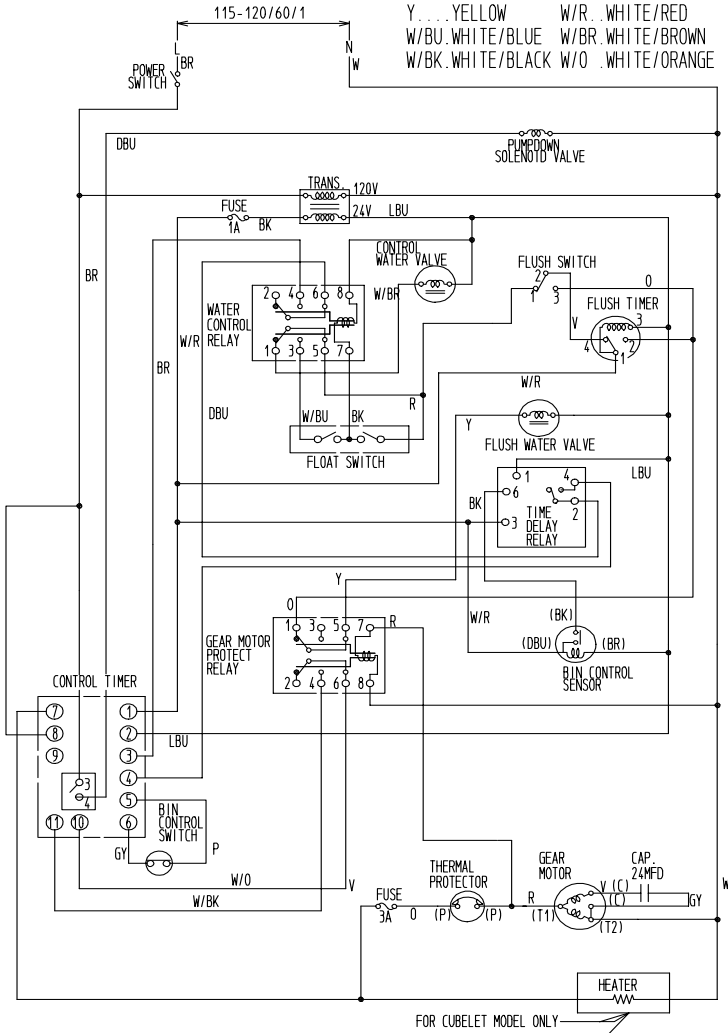

FOR CUBELET MODEL ONLY

3A3505-01Q

# V

## FS-1001MLH-C, with F-A board, FS-1022MLH-C, FS-1500MLH-C

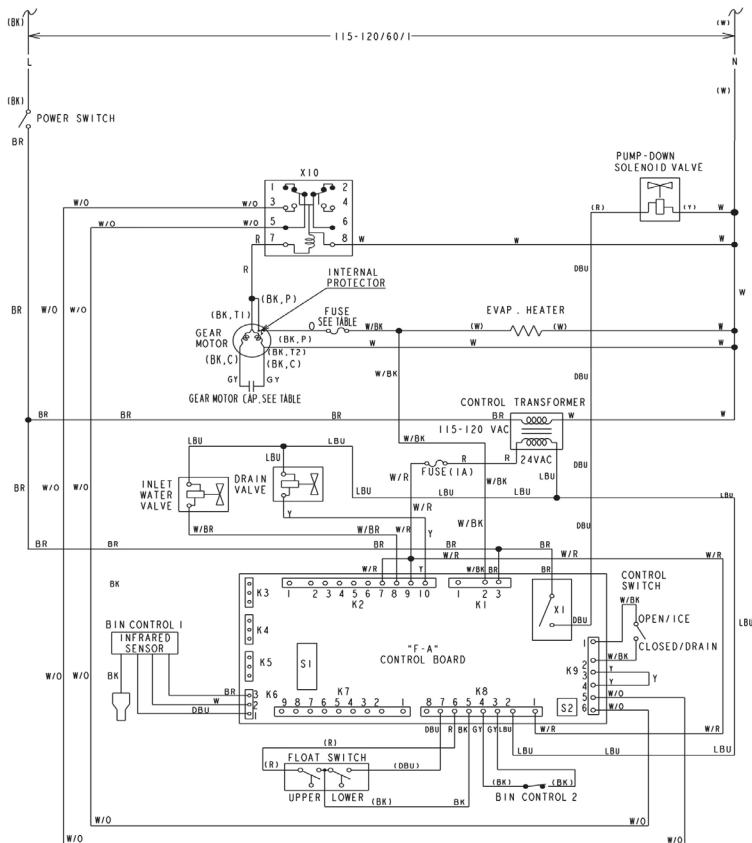

X1-PUMP-DOWN SOLENOID VALVE X10-COMPRESSOR CONTROL RELAY GEAR MOTOR PROTECT RELAY
---

MODEL	GEAR MOTOR CAP.	GEAR MOTOR FUSE
FS-1001MLH-C	2.4MFD	3A
FS-1022MLH-C		
FS-1500MLH-C	6.5MFD	7A

**SI DIP SWITCH SETTINGS**

MODEL	1	2	3	4	5	6	7	8	9	10
FS-1001MLH-C	ON	OFF	OFF	OFF	OFF	OFF	ON	ON	OFF	OFF
FS-1022MLH-C	ON	OFF	OFF	OFF	OFF	OFF	ON	ON	OFF	OFF
FS-1500MLH-C	ON	OFF	OFF	OFF	OFF	OFF	ON	ON	OFF	OFF

WIRE	COLOR CODE
BK	-BLACK
BR	-BROWN
BU	-BLUE
DBU	-DARK BLUE
GR	-GREEN
GY	-GRAY
LBU	-LIGHT BLUE
O	-ORANGE
P	-PINK
R	-RED
V	-VIOLET
W	-WHITE
Y	-YELLOW
W/BK	-WHITE BLACK
W/BR	-WHITE BROWN
W/BU	-WHITE BLUE
W/O	-WHITE ORANGE
W/R	-WHITE RED

# W

## SRC-10H, SRC-14H

### Used with FS-MLH models.

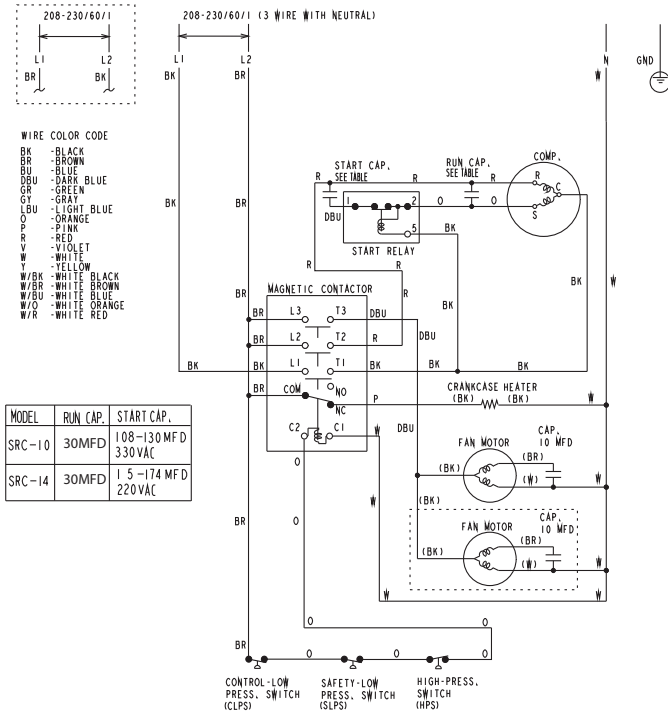

* Control Low-Pressure Switch	
Cut-in	29±0.5 PSIG
Differential	20±1.0 PSIG
Cut-out	9 PSIG

** Safety Low-Pressure Switch (Manual Reset)	
Cut-out	3±2.5 PSIG
Differential	6 PSIG

*** High-Pressure Switch	
Cut-out	384±20 PSIG
Cut-in	284±22 PSIG

# X F-150MAH(-C), MWH(-C), MRH(-C)

BK . . . BLACK	O . . . ORANGE
BR . . . BROWN	P . . . PINK
DBU . . . DARK BLUE	R . . . RED
GY . . . GRAY	V . . . VIOLET
LBU . . . LIGHT BLUE	W/O . . . WHITE
Y . . . YELLOW	W/R . . . WHITE/RED
W/BU . . . WHITE/BLUE	W/BR . . . WHITE/BROWN
W/BK . . . WHITE/BLACK	W/O . . . WHITE/ORANGE

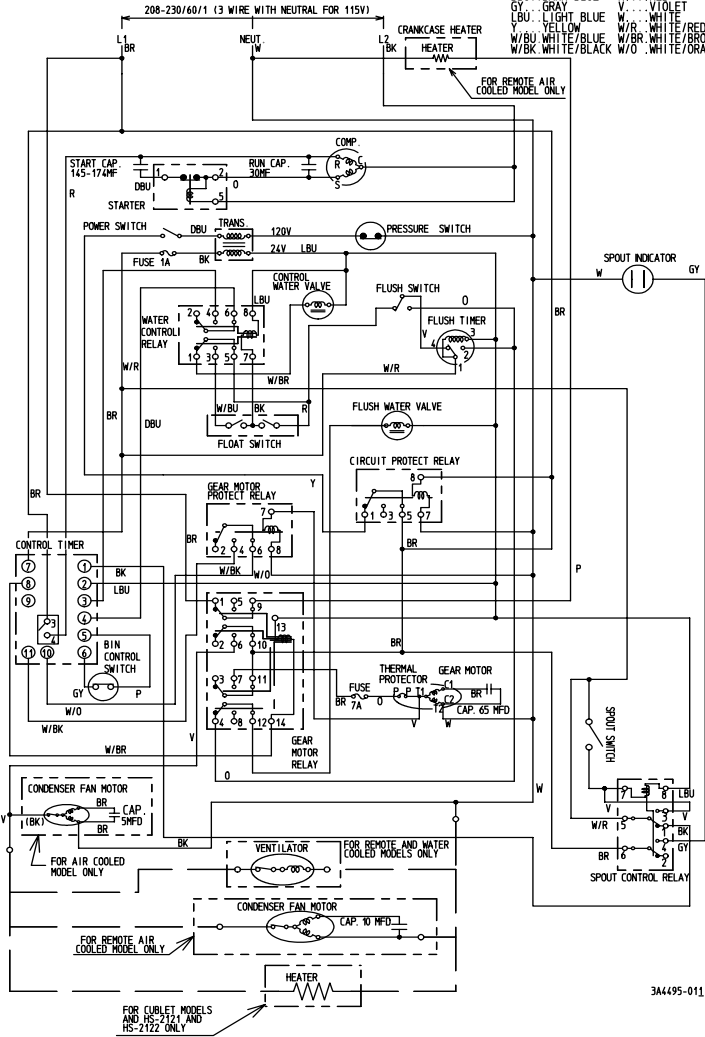

3A4495-011

# Y F-1501M\_H(-C)

S1 DIP SWITCH SETTING	1	2	3	4	5	6	7	8	9	10
F-1501M_H(-C)	ON	OFF	OFF	OFF	OFF	OFF	ON	ON	OFF	OFF

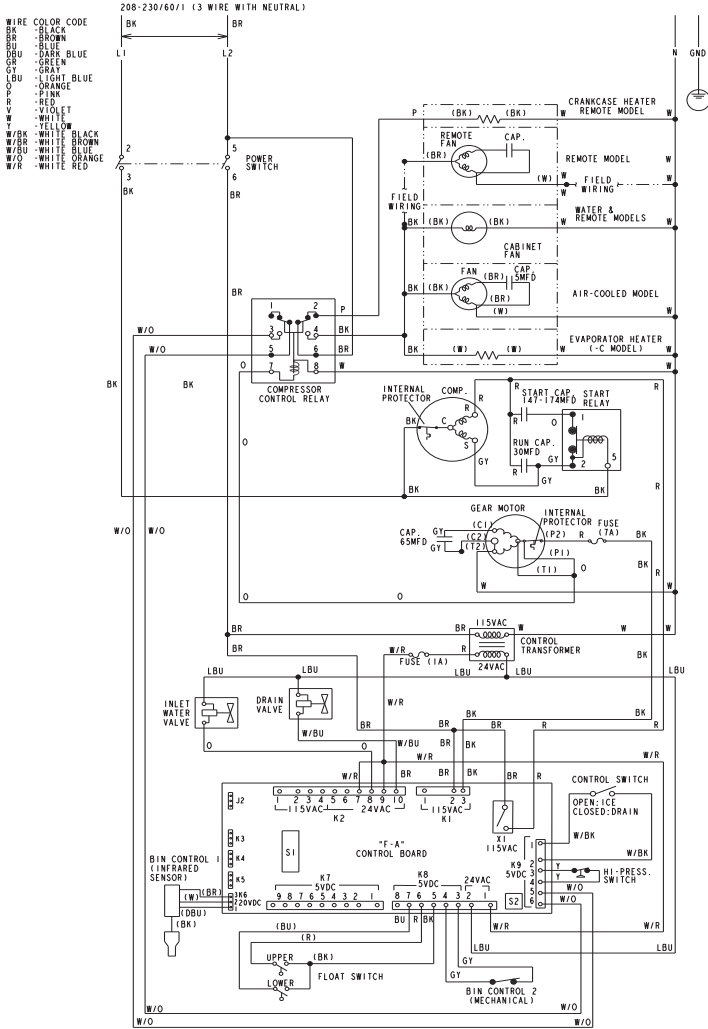

# Z

## F-2000MWH(-C), F-2000MRH(-C)

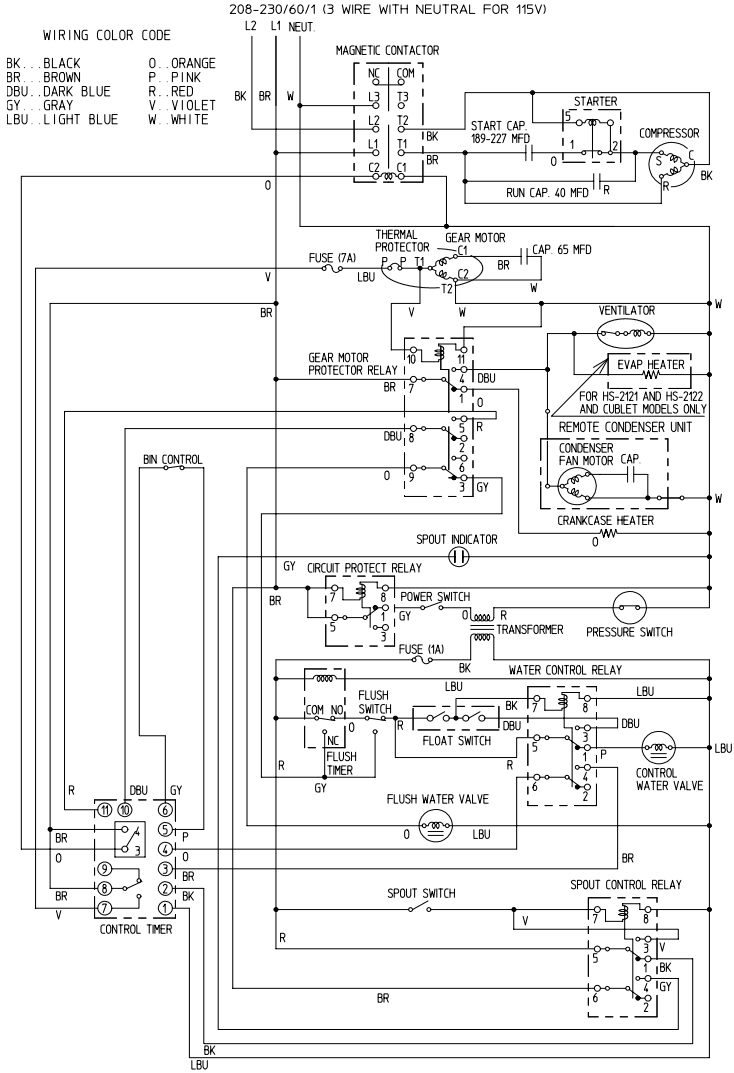

# AA

## F-2000MWH3(-C), F-2000MRH3(-C)

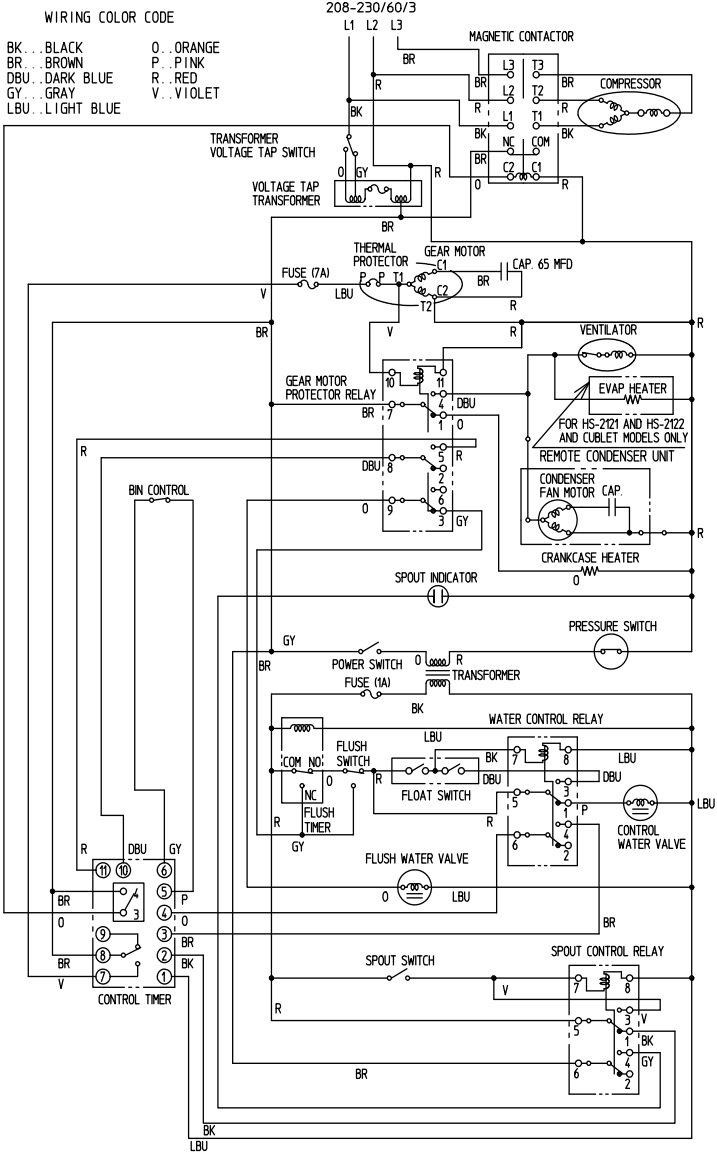

# BB F-2000MLH(-C)

## WIRING COLOR CODE

BK	BLACK	O	ORANGE
BR	BROWN	P	PINK
DBU	DARK BLUE	R	RED
GY	GRAY	V	VIOLET
LBU	LIGHT BLUE	W	WHITE

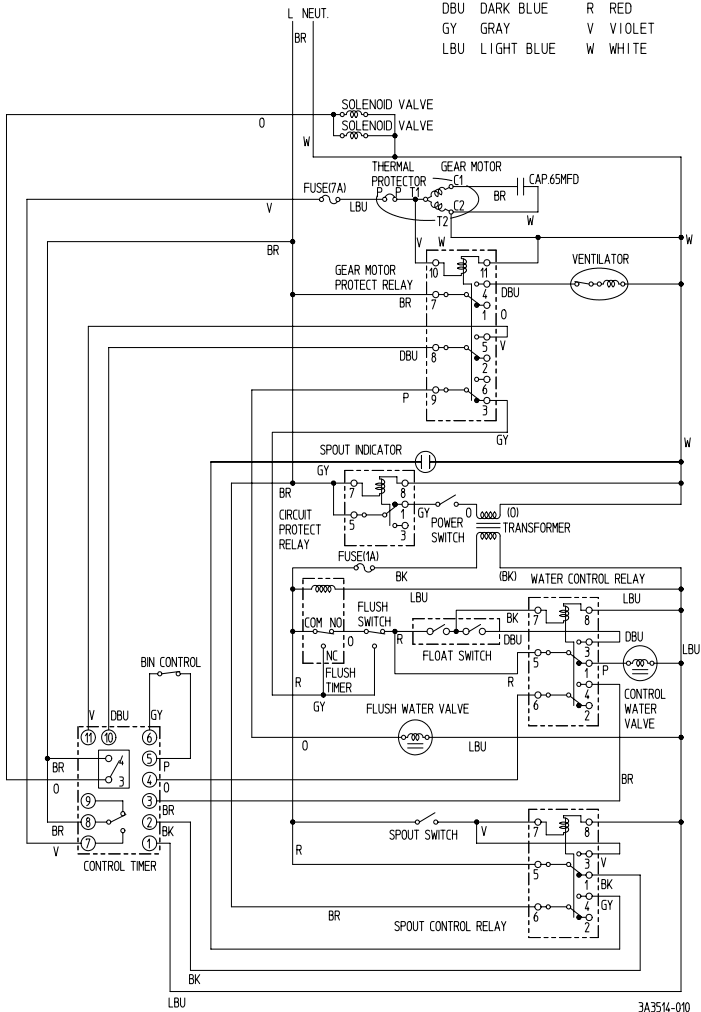

3A3514-010



# CC F-2001MWH3(-C), MRH3(-C)

SI DIP SWITCH SETTING	1	2	3	4	5	6	7	8	9	10
F-2001M_H /-C	ON	OFF	OFF	OFF	OFF	OFF	ON	ON	OFF	OFF
F-2001M_H3 /-C										

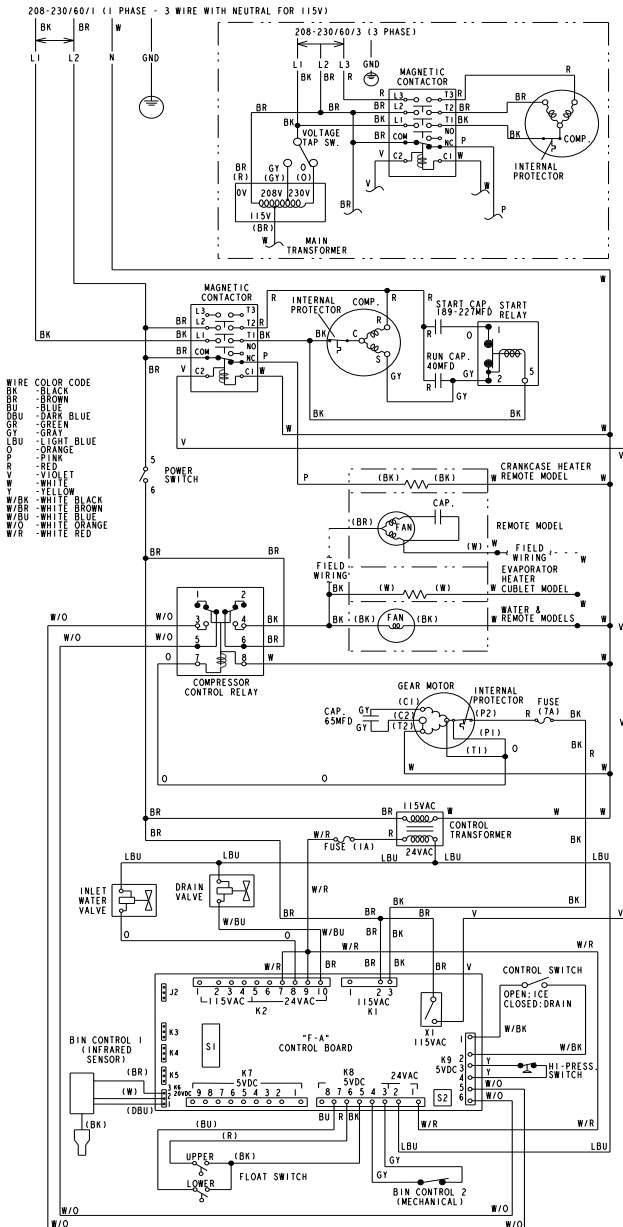

# NOTES