

► Everything You NEED to KNOW About TXVs

With the higher SEER air conditioners, technicians need to reacquaint themselves with **thermostatic expansion valves**

BY AL MAIER

Before the 13 SEER minimum efficiency standard, thermostatic expansion valves (TXVs) were rarely seen in residential air-conditioning systems. They were used on some high SEER systems and on heat pumps (usually on the outdoor coil), but these represented a relatively small portion of the overall market.

However, that has changed dramatically now that virtually all new 13 SEER equipment will be manufactured with TXVs. As a result, there is a growing need for many service technicians to reacquaint themselves with TXVs in terms of operation, troubleshooting and replacement.

Refrigerant flow

Metering the flow of refrigerant to the evaporator is the sole function of a TXV. It must meter this flow at precisely the same rate the refrigerant is being vaporized by the heat load. The

TXV does this by keeping the coil supplied with enough refrigerant to maintain the right superheat of the suction gas leaving the evaporator coil.

There are three forces that govern the TXV operation. Refer to Figure 1, which shows the basic force balance diagram of a TXV. In the chart:

P1: Power element and remote bulb pressure.

P2: Evaporator pressure.

P3: Superheat spring equivalent pressure.

For the valve to be stable, the forces need to be balanced, or $P1 = P2 + P3$.

needed to initiate movement of the valve pin to just start to move. This is defined as .002-inch of stroke.

► **Gradient.** The amount of superheat required to move the pin from the static set point to the rated stroke is called gradient. Figure 2 depicts how a TXV regulates flow in response to changing superheat.

Starting from the origin, no change in valve stroke occurs as the superheat slowly increases. It is not until the static setpoint is reached that the valve begins to open. From this point forward, further increase in superheat results in a proportional

Figure 1
In a TXV, the forces need to be balanced for it to be stable.

As the evaporator outlet temperature becomes warmer, the pressure (P1) increases, causing the diaphragm to flex in a downward direction. This forces the valve pin in an open position, resulting in increased refrigerant flow.

The underside of the diaphragm always senses the evaporator pressure (P2). As this pressure increases, it forces the diaphragm in an upward, or closing position, decreasing refrigerant flow.

The spring pressure (P3) also acts on the underside of the diaphragm. This spring is adjusted to provide static superheat for the valve. The static superheat is the amount of superheat

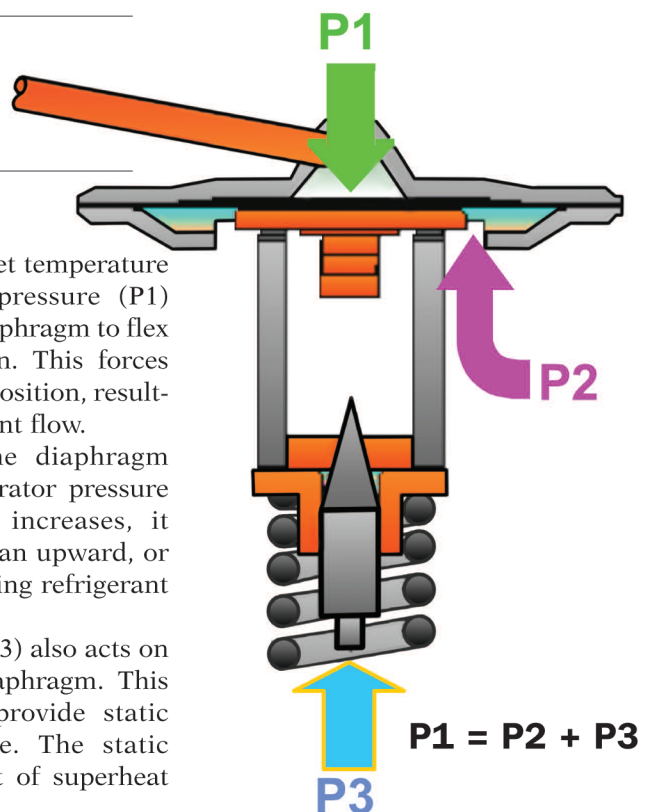

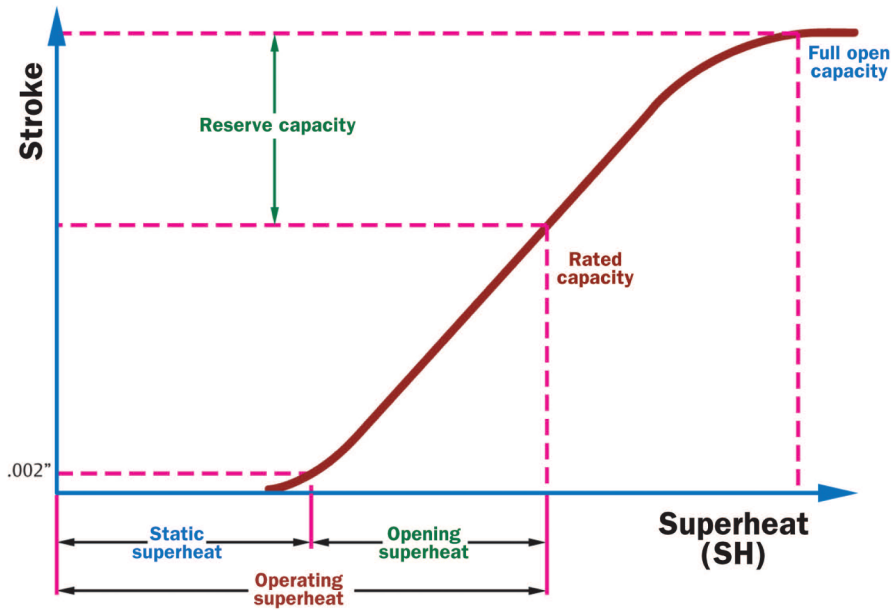

Figure 2
A TXV regulates flow in response to charging superheat.

increase in valve stroke until the maximum stroke position is attained.

Gradient is an important aspect to TXV performance in a system. Too low a gradient and the valve will be unstable and tend to “hunt” (more on this later). If the gradient is too high, more superheat will be needed for the valve to open, resulting in high operating superheat and poor evaporator efficiency.

► **Measuring superheat.** Since good superheat control is the criterion of TXV performance, accurate measurement of the superheat is vital. This involves four steps, as shown in Figure 3. They are:

1. Measure the suction pressure at the evaporator outlet with an accurate gauge. If a gauge connection is not available, a tee can be installed in the equalizer line.

2. Referring to a P/T chart for the refrigerant used in the system, find the saturation temperature that corresponds to the pressure observed in step 1.

3. Measure the temperature of the suction line at the remote sensing bulb. This can be done with a strap-on type thermometer or an electronic device.

4. Subtract the saturation temperature determined in step 2 from the

suction gas temperature measured in step 3. The difference is the operating superheat.

► **Internally and externally equalized TXVs.** In a system with a relatively small evaporator, the pressure drop across that evaporator is so small you can assume it is zero. Therefore, the TXV outlet pressure

In most a/c systems, the evaporators are quite large and, therefore, have significant pressure drop across them

and evaporator outlet pressure are equal.

By drilling a small bleed passage between the underside of the diaphragm and the outlet of the valve, you can sense the pressure internally and eliminate the need for an external connection. Valves pro-

duced in this manner are termed internally equalized valves.

In most a/c systems, the evaporators are quite large and, therefore, have significant pressure drop across them. For the TXV to sense the evaporator outlet pressure, a separate line is needed from the suction line (near the TXV bulb location) to the external equalizer connection on the valve body.

If a distributor is used to supply refrigerant to various evaporator circuits, an externally equalized valve must be used. Distributors typically have between 15 psi and 30 psi pressure drop across them. Hence, use them only with externally equalized valves.

► **Balanced-ported valves.** With a conventional TXV, the pressure differential across the valve results in a force that tends to “open” the valve. As operating conditions vary, this pressure differential changes and results in a variation of the original superheat. Engineers have developed the balance-ported TXV to compensate for this (Figure 4).

In this design, the inlet pressure is applied across the valve pin as well as an undercut on the push-rod. Since these forces are in opposite directions, they cancel or balance one another resulting in no change in superheat, regardless of operating conditions.

Balanced-ported valves are ideal for use in systems that operate over large changes in operating conditions. An example of this is a commercial a/c system that must operate both winter and summer, resulting in system operation under widely varying head pressures.

Troubleshooting TXVs

There are really only three failure modes that a TXV can experience:

1. **Starving.** This is defined as insufficient refrigerant flow causing high superheat at the evaporator outlet. Symptoms include high superheat at the compressor inlet, high discharge temperature and possibly compressor overheating (the protector trips).

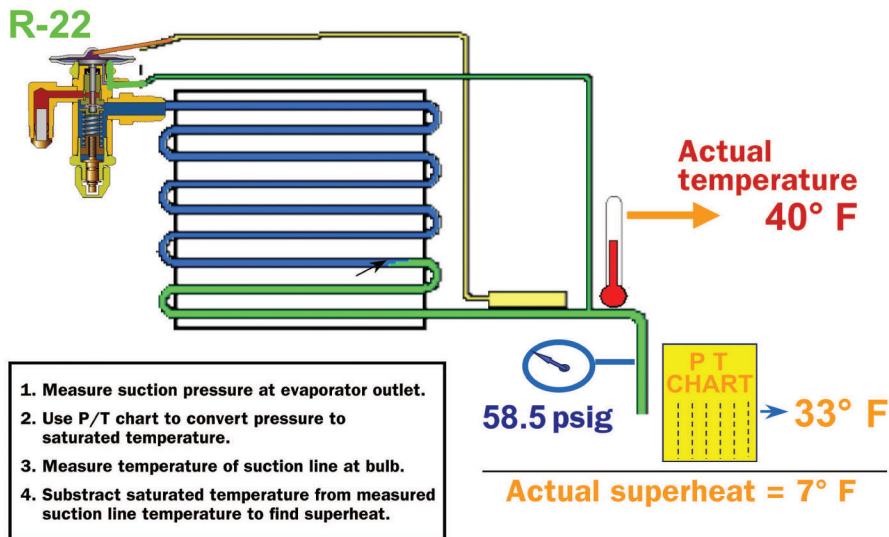

Figure 3
Four steps are required to accurately measure superheat.

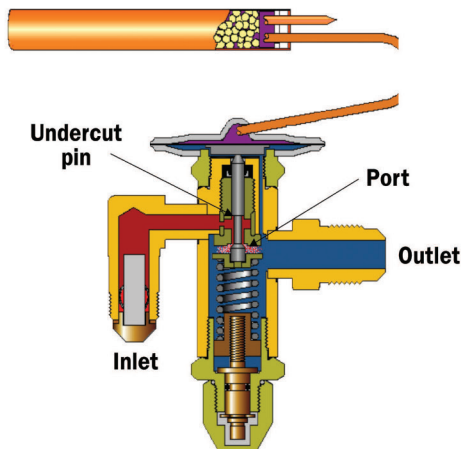

Figure 4
The balanced port TXV compensates for varying operating conditions.

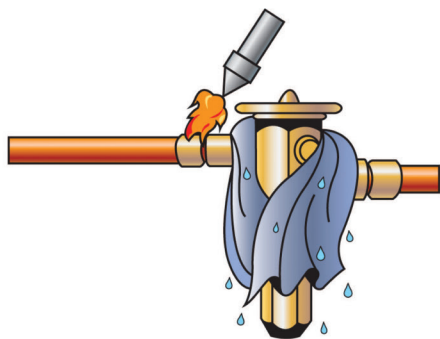

Figure 5
Wrap the valve with wet rags to avoid overheating.

2. Flooding. This occurs when the refrigerant flow to the evaporator is so high that all of it can't evaporate within the coil. The result is liquid refrigerant getting back to the compressor. Symptoms include low evaporator superheat, diluted oil and noisy compressors. If not corrected, this can lead to permanent compressor damage.

3. Hunting. When the superheat in an operating system is constantly changing from little or no superheat to very high superheat, it is called hunting. You can easily recognize this by noting extreme cyclic changes in the evaporator or suction pressure.

Hunting is caused by many factors, but usually occurs when the valve is oversized for the load. Before condemning a valve for this symptom, make certain the evaporator is clear of frost and has proper airflow since these conditions will result in very low loads potentially resulting in a "good" valve hunt.

Checking TXV operation

If a TXV is suspected of working properly, checking the superheat is the only way to know for sure. Do this with accurate instrumentation to get meaningful results.

Check the a/c equipment manufacturer's installation and service manual to verify the acceptable superheat

for that particular model. As a rule of thumb, operating superheats between 8° F to 12° F is considered normal.

Some "tips" to help in troubleshooting TXV performance follow:

- Check the bulb to assure it is properly connected to the suction line. If you can move the bulb by hand, then it is not secured adequately.
- Some manufacturers insulate the bulb to protect it from the effects of an airstream. If this was done by the oem, make sure the insulation is still intact.

- Check the equalizer line for restrictions (kinks) or signs of frost. A frosted equalizer line indicates internal leakage and will require replacement of the valve. You will need to repair or replace a kinked equalizer as well for the valve to operate properly.

A TXV is designed to meter the flow of liquid refrigerant. If the refrigerant at the valve inlet contains flash gas the capacity of the valve will be reduced. Make certain the system is properly charged and that some subcooling exists at the inlet of the valve before condemning the TXV.

With the use of R-410A and POE oils, there is a greater risk of dirt and contaminants being circulated within the system. Some manufacturers use inlet strainers or screens to prevent debris from clogging the valve.

If such a condition is found, clean and replace the strainer. It would also be wise to install a large filter/drier at the inlet of the TXV to prevent a recall.

Replacing a TXV

If you determine that you need to replace the valve after checking the superheat, here are some tips to assure proper replacement:

1. Whenever possible, use the valve recommended by the manufacturer of the equipment. If this is not possible, be sure the replacement has the same:

- Rated capacity.
- Refrigerant designation.
- Charge type.
- Internal/external equalizer style.

- Internal check valve (if supplied on original valve).
- Inlet/outlet connection size and type.

2. To maintain system cleanliness, replace the filter-drier whenever opening the sealed system. While this always has been a recommended service procedure, it is of even greater importance with HFC/POE systems due to the hygroscopic nature of the POE oils and their greater solvency.

3. Do not overheat the valve during the brazing process. Overheating can cause deterioration of the internal seals, which could lead to frosted equalizer lines. To avoid this:

- Wrap the valve with wet rags as shown in Figure 5.
- Keep the torch flame pointed away from the valve body.
- Never allow the torch to come in contact with the bulb.

TXVs in heat pumps

In heat pump applications, the liquid refrigerant must flow through or around the TXV when operating in the reverse direction. Historically, this was accomplished by installing a check valve around the valve.

However, in recent years TXV manufacturers have modified their products with internal check valves. Many OEMs have adopted these since they eliminate joints and the potential for leaks.

Figure 6 is a cross-sectional drawing of one such valve. In the forward flow direction, inlet pressure pushes

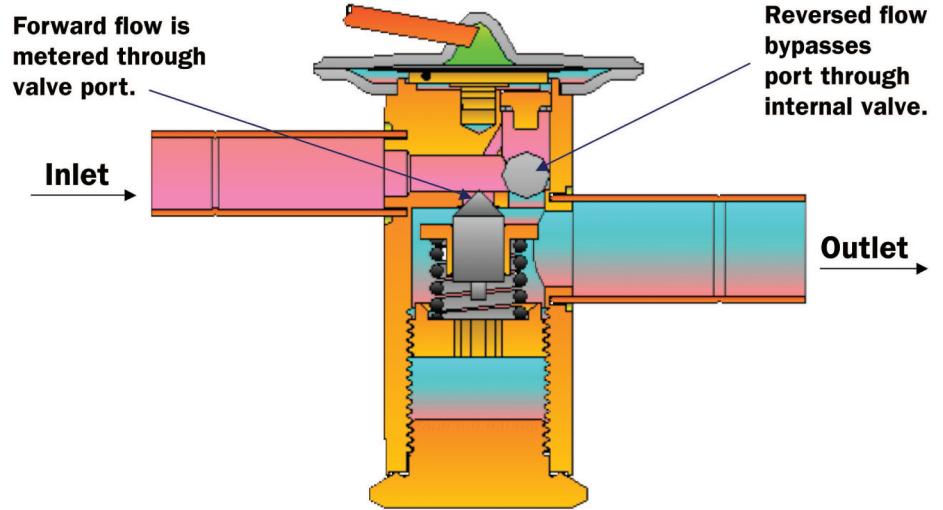

Figure 6
Here is a diagram of an internal check valve.

the ball against the seat, forcing it closed. All the flow must then pass through the main valve port and the valve operates as a normal valve.

When the flow is reversed the inlet pressure pushes the ball up, allowing flow through the check port. In this mode, the flow bypasses the main port and liquid will flow through the valve with only a small pressure drop.

When replacing a valve in a heat pump verify if the original valve had an internal check. If it did, be sure the replacement has one too. If none is available, use a standard valve. You must install a check valve to bypass the TXV when reverse flow is encountered.

Systems using TXVs are quickly becoming the norm in this post 13-SEER world. Understanding their function and operation will enable you to properly service systems using these devices. Follow the basic troubleshooting and replacement guidelines discussed here, to ensure optimal system performance and prevent permanent compressor damage.◆

Al Maier has over 30 years of refrigeration system and component design experience. He is currently a retired employee of Emerson.